

TECHNICAL MANUAL

OPERATOR, ORGANIZATIONAL,
DIRECT SUPPORT AND GENERAL SUPPORT MAINTENANCE MANUAL

SCHEMATICS FOR

GUIDED MISSILE REMOTE CONTROL SYSTEM SHOP EQUIPMENT

AN/TSM-104 4935-01-051-8691 (SHOP 3)

AN/TSM-105 4935-00-782-1957 (MTS)

AN/TSM-179 4935-01-218-7089 (SHOP 1)

AN/TSM-146 4935-01-083-3129 (SHOP 1)

AN/TSM-169 4935-01-166-2185 (SHOP 2)

AN/TSM-177 4935-01-233-9088 (SHOP 9)

AN/TSM-145 4935-01-085-5618 (SHOP 9)

AND

SUPPLEMENTARY EQUIPMENT GUIDED MISSILE TEST STATION

AN/TSM-180 4935-01-223-9122 (TAG)

AN/TSM-148 4935-01-085-5679 (TAG)

This copy is a reprint which includes current
pages from Changes 1 thru 14

HAWK AIR DEFENSE GUIDED MISSILE SYSTEM

WARNING**RADIATION HAZARD**

This equipment contains the following radioactive items:

<i>Nomenclature</i>	<i>NSN</i>	<i>Isotope</i>	<i>Amount (Microcuries)</i>
Electron tube OA2WA	5960-00-503-4880	*	*
Electron tube OB2WA	5960-00-262-3763	UO 2	0.10
Electron tube 6627/OB2WA	5960-00-624-4718	*	*
Electron tube 5787WA	5960-00-272-8545	*	*

*Isotope and level of activity varies among manufacturers. Refer to TB 43-0116.

Refer to TM 3-261, TM 38-250, and TB 43-0116 for information relative to shipping, storage, handling, and disposal of radioactive material.

FIRST AID FOR RADIOACTIVE CONTACT

The following first aid procedure for wounds caused by anything coated with a radioactive particle material represent the only reasonable first aid treatment which would possibly be available:

- Stimulation of mild bleeding by normal pressure about the wound and by use of suction cups.

WARNING

Do not suck the wound by mouth. The wound must be washed with soap and flushed with plenty of clear water

- If the wound is of the puncture type, or the opening is quite small, an incision should be made to promote free bleeding and to facilitate cleaning and flushing of the wound.

- Evacuate patient to a medical facility where monitoring of the wound can be accomplished. All such wounds should be examined by a medical officer.

- For wounds involving the extremities, pending medical attention, place a lightly constricting band (tourniquet) 2 to 4 inches closer to the heart than the site of the wound. The band should be tight enough to halt the flow of blood in superficial blood vessels but not tight enough to stop the pulse (arterial flow).

CLEANING SURFACES ON WHICH TUBES HAVE BEEN BROKEN

Wet Method. Put on rubber or plastic gloves. Pick up large fragments with forceps then, using a wet cloth, wipe across the area. Make one wipe at a time and fold cloth in half, using the clean side for wiping each time. When cloth becomes too small, discard and start again with a clean piece of cloth. Care must be taken not to rub the radioactive particles into the surface being cleaned by using a back and forth motion. All debris and cloths used for cleaning should be sealed in a container such as a plastic bag, heavy waxed paper, ice cream carton, or glass jar for disposal.

WARNING FOR RADIO-FREQUENCY RADIATION HAZARD

Radio-frequency (*rf*) radiation from radar antennas and associated equipment is a potential hazard to personnel. Rf radiation is not cumulative but it can be hazardous. It heats the body tissues, and, if the radiation intensity is sufficiently high, will permanently damage the tissue. This damage is not immediately apparent.

Precautions should be taken to ensure that personnel are not exposed to rf radiations of hazardous intensity levels. Personnel who must be within the hazardous distances for the below listed radars should be instructed not to place themselves on the radiating side of the antenna and to never look into a transmitting horn or open waveguide which is connected to an energized transmitter.

Personnel are prohibited from entering areas where they may be exposed to levels of rf radiation above 10 milliwatts per square centimeter (10 mw/cm^2). This level, though not considered hazardous, is stipulated by AR 40-583 as the maximum permissible exposure level for personnel.

A power intensity of at least 10 mw/cm^2 is present along the axis of each radar's transmitted beam, for the distances listed below. These distances are based on calculations and actual measurements and may be used as a guide to prevent radio-frequency radiation injury. In each instance, radiation intensity rapidly diminishes as the distance is increased.

ANTENNA	DISTANCE
High-powered Illuminator Radar	111.5 m (366 ft)
Cw Acquisition Radar non-scanning	74 m (243 ft)
scanning	36 m (118 ft)
Pulse Acquisition Radar	15.2 m (50 ft)
Range-only Radar	45.1 m (148 ft)

In HIPIR AN/MPQ-61, the wide angle illuminator (WAI) antenna, which provides low altitude simultaneous HAWK engagement (LASHE) has the capability to produce a power density level greater than 10 mw/cm^2 to a range of 11 meters (36 feet) in the main beam.

The 36 m distance for the scanning CWAR antenna does not mean the system constitutes a hazard to personnel while the antenna is scanning. When the antenna stops scanning and is stationary, those systems capable of producing power densities greater than 50 mw/cm^2 must be controlled so that under no circumstances will personnel be exposed to intensities equal to or greater than 50 mw/cm^2 . When the radar is energized to full radiate, personnel must not be within 74 meters (243 feet) of the antenna along the designated azimuth.

No radiation hazard exists at radar ground level if the radars are not depressed below zero degrees elevation. When at all possible during maintenance, however, place the antenna at a high elevation. Personnel are restricted from the area atop the radars or other elevated locations in front of the antennas when radiating.

Personnel may move in and around the CWAR to zero range at ground level provided they are below the horizontal center line of the antennas. There is no height restriction to either side or rear of the antennas.

Potentially hazardous power density levels do not exist in the radiation field of the pulse acquisition radar when scanning.

The above information is applicable to typical HAWK sites. The services of the U.S. Army Environmental Hygiene Agency are available, in accordance with the provisions of AR 40-583 for the evaluation of potential radio-frequency hazards at sites where unusual operating or site conditions may exist.

WARNING**DANGEROUS VOLTAGE**

is used in the operation of this equipment

DEATH ON CONTACT

may result if personnel fail to observe safety precautions

Never work on electronic equipment unless there is another person nearby who is familiar with the operation and hazards of the equipment and who is competent in administering first aid. When the technician is aided by operators, he must warn them about dangerous areas.

Whenever possible, the power supply to the equipment must be shut off before beginning work on the equipment. Take particular care to ground every capacitor likely to hold a dangerous potential. When working inside the equipment, after the power has been turned off, always ground every part before touching it.

Use extreme caution when operating equipment protected by interlocks. Ensure that interlocks (doors, panels, and drawers) are functioning properly. (TM 9-1425-525-12-4)

Be careful not to contact high-voltage connections when installing or operating this equipment.

Whenever the nature of the operation permits, keep one hand away from the equipment to reduce the hazard of current flowing through the vital organs of the body.

WARNING

Do not be misled by the term "low voltage." Potentials as low as 50 volts may cause death under adverse conditions.

For artificial respiration, refer to FM 21-11.

EXTREMELY DANGEROUS POTENTIALS
greater than 500 volts exist in the following units:

High-voltage power supply
Oscilloscope
Power distribution panel

WARNING**HIGH NOISE LEVEL WHEN SHOP EQUIPMENT IS OPERATING**

Various combinations of the air conditioner, consoles, and accessories produce dangerously loud noises when operating. Without protection, long exposure to this noise can cause a hearing loss. Ear protectors should be worn when working in a shop van. See AR 40-5 for additional information.

WARNING**DANGEROUS VACUUM TUBE**

is used in this equipment.

DEATH

or severe injury may result if personnel fail to observe safety precautions. The cathode-ray tube (CRT) is highly vacuumized and may implode when broken.

Beware of flying glass particles upon implosion.

Avoid breathing the gases released when a tube is broken.

When handling CRT's or equipment containing CRT's, wear protective gloves; apron, and face mask to minimize or avoid injury.

C10

WARNING
DANGEROUS CHEMICALS
are used in the operation
of this equipment
DEATH

may result if personnel fail
to observe safety precautions

The following is a list of chemicals used in the operation or maintenance of the equipment in this manual, including proper care and handling procedures and corrective actions (fire and first aid procedures).

Item (NSN/APN)	Care and Handling Procedures	Corrective Actions
Methyl chloroform 1, 1, 1- trichloroethane	<p>Flammable. Avoid heat, sparks, and open flames.</p> <p>Excessive inhalation can cause drowsiness, dizziness, drunkenness, unconsciousness, and death at extreme doses.</p> <p>Avoid prolonged or repeated contact with skin. Wear protective gloves.</p> <p>Avoid contact with eyes. Do not wear contact lenses when working with this material. Wear safety goggles. Avoid swallowing.</p>	<p>Use CO₂ or dry chemical extinguisher.</p> <p>Remove victim to fresh air. If not breathing, perform artificial respiration. If breathing is difficult, give oxygen. Get medical attention.</p> <p>Wash skin promptly and thoroughly with flowing water or shower for 5 to 15 minutes.</p> <p>Flush eyes promptly with water for 5 to 15 minutes.</p>
Electrolyte (sulfuric acid)	<p>Non-flammable. Can ignite finely divided combustible materials.</p> <p>Vapors can cause irritation of nose and throat.</p> <p>Avoid contact with skin. Can cause severe irritation, burns, and ulceration. Wear safety clothing.</p> <p>Avoid contact with eyes. Can cause severe irritation, corneal damage, and blindness. Wear safety goggles.</p> <p>Avoid swallowing. Can cause severe damage or death.</p>	<p>Do not induce vomiting. Get medical attention.</p> <p>Use CO₂ or dry chemical extinguisher.</p> <p>Remove victim to fresh air. If not breathing, perform artificial respiration. Get medical attention.</p> <p>Remove soaked clothing promptly. Wash skin thoroughly with large amounts of water. Get medical attention.</p> <p>Flush eyes promptly with large amounts of water. Get medical attention.</p> <p>Give victim large amounts of water, if conscious. Get medical attention.</p>

WARNING
DANGEROUS CHEMICALS
Continued

Item (NSN/APN)	Care and Handling Procedures	Corrective Actions
Dry cleaning solvent type 1 P-D-680	<p>Flammable. Avoid heat, sparks, and open flame.</p> <p>Excessive inhalation can cause headache, dizziness, and nausea. Use with adequate ventilation. When heated, may yield carbon monoxide.</p> <p>Avoid prolonged or repeated contact</p> <p>Avoid contact with eyes. Vapor is irritating to eyes. Do not wear contact lenses when working with this material. Wear safety goggles.</p> <p>Avoid swallowing.</p>	<p>Use CO₂ or dry chemical extinguisher.</p> <p>Remove victim to fresh air. If not breathing, perform artificial respiration. Get medical attention.</p> <p>Wash skin promptly and thoroughly with skin. with mild soap and water. Apply skin cream.</p> <p>Flush eyes promptly and thoroughly with water. Get medical attention.</p> <p>Do not induce vomiting. Get medical attention.</p>
Butyl alcohol OC 265.	<p>Extremely flammable. Avoid heat, sparks, and open flame. under almost all normal temperatures. Vapors are toxic. Can produce symptoms of intoxication. Use with adequate ventilation.</p> <p>Avoid contact with skin.</p> <p>Avoid contact with eyes. Wear safety goggles.</p> <p>Avoid swallowing. Can cause severe nausea, vomiting, abdominal pain, bleeding and central nervous system</p>	<p>Use CO₂ or dry chemical extinguisher.</p> <p>Remove victim to fresh air. If not breathing, perform artificial respiration. If breathing is difficult, give oxygen. Get medical attention.</p> <p>Remove soaked clothing promptly. Wash skin thoroughly with water for 15 minutes minimum. Get medical attention.</p> <p>Flush eyes promptly with water for 15 minutes minimum. Get medical attention.</p> <p>Never give anything by mouth to an unconscious person. If victim is not alert, give black coffee and active charcoal. If victim is alert, induce vomiting. Get medical attention.</p>

C10

WARNING
DANGEROUS CHEMICALS
Continued

Item (NSN/APN)	Care and Handling Procedures	Corrective Actions
Methanol OM232, grade A	<p>Flammable. Avoid heat, sparks, and open flame.</p> <p>Vapors can cause headache, dizziness, weakness, gastrointestinal or visual disturbance.</p> <p>Avoid contact with skin. Wear rubber gloves.</p> <p>Avoid contact with eyes. Wear safety goggles.</p> <p>Avoid swallowing. Can cause drowsiness, visual disturbances, possible blindness.</p>	<p>Use CO₂, dry chemical or "alcohol type" foam extinguisher.</p> <p>Remove victim to fresh air. If not breathing, perform artificial respiration. If breathing is difficult, give oxygen. Keep victim warm and cover eyes to exclude light. Get medical attention.</p> <p>Remove soaked clothing promptly. Wash skin thoroughly with large amounts of water for 15 minutes minimum. Get medical attention.</p> <p>Flush eyes promptly with large amounts of water for 15 minutes minimum.</p> <p>If conscious, give victim large amounts of soapy water and induce vomiting. Get medical attention.</p>
Isopropyl alcohol, technical TT 1735 grade 3	<p>Flammable. Avoid heat, sparks, and open flame. Fumes may spread long distances and flash back.</p> <p>Vapors can cause irritation of nose and throat.</p> <p>Avoid prolonged or repeated contact with skin. Wear protective gloves.</p> <p>Avoid contact with eyes. Can cause corneal burns and eye damage. safety goggles.</p> <p>Avoid swallowing. Can cause depression, dizziness, headache, vomiting, and unconsciousness. Can cause death.</p>	<p>Use CO₂, dry chemical or "alcohol type" foam extinguisher.</p> <p>Remove victim to fresh air. If not breathing, perform artificial respiration. If breathing is difficult, give oxygen. Get medical attention.</p> <p>Remove soaked clothing promptly. Wash skin thoroughly with soap and water for 5 minutes minimum. Get medical attention.</p> <p>Flush eyes promptly with water for 15 minutes minimum. Get medical attention.</p> <p>Get immediate medical attention.</p>

WARNING
DANGEROUS CHEMICALS
Continued

Item (NSN/APN)	Care and Handling Procedures	Corrective Actions
Insulation varnish MIL-V-173	<p>Flammable. Avoid heat, sparks, and open flame.</p> <p>Vapors can cause drowsiness, headache, dizziness and irritation of eyes, nose and throat. Use with adequate ventilation.</p> <p>Avoid prolonged or repeated contact with skin. Wear rubber gloves. skin cream.</p> <p>Avoid contact with eyes. Wear safety goggles.</p> <p>Avoid swallowing.</p>	<p>Use CO₂ or dry chemical extinguisher.</p> <p>Remove victim to fresh air. If not breathing, perform artificial respiration. Get medical attention.</p> <p>Wash skin promptly and thoroughly with mild soap and water. Apply skin cream.</p> <p>Flush eyes promptly with water for 15 minutes minimum. Get medical attention.</p> <p>Do not induce vomiting. Get medical attention.</p>
Polychlorinated biphenyls (PCB) (contained in General Electric and Electrical Utilities capacitors located in the motor-generator assembly)	<p>Do not allow capacitors to become overheated. Replace any capacitors that show signs of swelling or leakage.</p> <p>If material leaks or vaporizes, persons in the area should wear protective clothing (paper suits, gloves, disposable booties, organic respirators) when disposing of contaminants.</p> <p>Excessive inhalation can cause nausea, vomiting, loss of weight, liver damage and abdominal pain. When liver damage is severe, it can be fatal.</p> <p>Avoid contact with skin. Wear protective gloves.</p> <p>Avoid contact with eyes. Do not wear contact lenses when working with this material. Wear safety goggles.</p> <p>Avoid swallowing.</p>	<p>Remove victim to fresh air and give oxygen if short of breath. If not breathing, perform artificial respiration. Keep victim warm. Get medical attention.</p> <p>Remove all ignition sources. Ventilate the area. If solid material is present, sweep onto paper or other suitable material and burn in safe place. If in a liquid form, absorb on paper towels. Evaporate in a safe place, then burn. PCB material can also be disposed of in an approved hazardous waste location.</p> <p>Remove victim to fresh air and give Get medical attention.</p> <p>Remove contaminated clothing promptly. Blot excess with paper towels. Wash skin thoroughly with soap and water for 15 minutes minimum.</p> <p>Flush eyes promptly with water for 15 minutes minimum. A drop of vegetable oil may be added to relieve irritation. Get medical attention.</p> <p>Get medical attention immediately.</p>

C12

WARNING
DANGEROUS CHEMICALS
 Continued

Item (NSN/APN)	Care and Handling Procedures	Corrective Actions
Toluene OC 265	<p>Flammable. Avoid heat, sparks, and open flame.</p> <p>Vapors can cause dizziness, headache or unconsciousness.</p> <p>Avoid prolonged or repeated contact with skin. Wear protective gloves and clothing.</p> <p>Avoid contact with eyes. Wear safety goggles.</p> <p>Avoid swallowing.</p>	<p>Use CO₂, dry chemical, "alcohol type" foam, water spray or fog extinguisher.</p> <p>Remove victim to fresh air. If breathing is irregular or stopped, perform artificial respiration. Get medical attention.</p> <p>Remove soaked clothing. Wash skin promptly and thoroughly with mild soap and water.</p> <p>Flush eyes promptly with clear water for 15 minutes minimum.</p> <p>Do not induce vomiting. Get medical attention.</p>
Mineral spirits	<p>Flammable. Avoid heat, sparks, and open flame.</p> <p>Vapors can cause dizziness, headache or unconsciousness.</p> <p>Avoid prolonged or repeated contact with skin. Wear protective gloves and clothing.</p> <p>Avoid contact with eyes. Wear safety goggles.</p> <p>Avoid swallowing.</p>	<p>Use CO₂, dry chemical, "alcohol type" foam, water spray or fog extinguisher.</p> <p>Remove victim to fresh air. If breathing is irregular or stopped, perform artificial respiration. Get medical attention.</p> <p>Remove soaked clothing. Wash skin promptly and thoroughly with mild soap and water.</p> <p>Flush eyes promptly with clear water for 15 minutes minimum.</p> <p>Do not induce vomiting. Get medical attention.</p>

WARNING
DANGEROUS CHEMICALS
 Continued

Item (NSN/APN)	Care and Handling Procedures	Corrective Actions
Freon (Cleaning compound solvent) (Ethylene glycol freon cleaning solvent)	<p>Non-flammable. Use in small quantities. Open flames, high temperatures, alkali or alkaline earth metals may cause hazardous decomposition with emission of hydrochloric and hydrofluoric acids which are possible carbonyl halides.</p> <p>Use in well-ventilated area. Vapors will concentrate in low areas. Excessive inhalation may cause lightheadedness, shortness of breath, possible stupor, and at high concentrations can affect heart rhythm. Use an air mask at high concentrations.</p> <p>Avoid prolonged or repeated contact with skin. Wear protective gloves. Avoid contact with eyes. Wear safety goggles.</p> <p>Avoid swallowing.</p>	<p>Absorb spills with paper, vermiculite, floor absorbent, or other absorbent material.</p> <p>Remove victim to fresh air. If not breathing, perform artificial respiration. If breathing is difficult, give oxygen. DO NOT give epinephrine or similar drugs, since such drugs may induce erratic heartbeat. Get medical attention.</p> <p>Wash skin promptly and thoroughly with mild soap and water. Immediately flush eyes thoroughly with water.</p> <p>If conscious, give two glasses of water. Induce vomiting immediately.</p> <p>If unconscious, DO NOT induce vomiting. Get medical attention.</p>
Dielectric coolant fluid OS45 type 2	<p>Avoid water contamination as mixture can become flammable. Excessive high temperature may produce irritating vapors.</p> <p>Avoid prolonged or repeated contact with skin.</p> <p>Avoid contact with eyes. Wear safety goggles.</p>	<p>Use CO₂ or dry chemical extinguisher.</p> <p>Remove victim to fresh air.</p> <p>Wash promptly and thoroughly.</p> <p>Flush eyes promptly and thoroughly with water. Get medical attention.</p>

WARNING
DANGEROUS CHEMICALS
Continued

Item (NSN/APN)	Care and Handling Procedures	Corrective Actions
Coolant (Union Carbide PM-3961)	<p>Flammable. Avoid open flames and sparks.</p> <p>Avoid contact with skin. Wear rubber gloves. Wash thoroughly with water.</p> <p>Avoid contact with eyes. Wear safety goggles. Wash thoroughly with water.</p> <p>Avoid swallowing. Can cause damage to the central nervous system and severe kidney damage.</p>	<p>Use CO₂ or dry chemical extinguisher.</p> <p>Wash skin promptly and thoroughly with water.</p> <p>Flush eyes promptly and thoroughly with water.</p> <p>Get medical attention immediately.</p>
Dielectric coolant fluid OS59 type 3	<p>Avoid water contamination as mixture can become flammable. Excessive high temperature may produce irritating vapors.</p> <p>Avoid prolonged or repeated contact with skin.</p> <p>Avoid contact with eyes. Wear safety goggles.</p> <p>Get medical attention.</p>	<p>Use CO₂ or dry chemical extinguisher.</p> <p>Remove victim to fresh air.</p> <p>Wash skin promptly and thoroughly.</p> <p>Flush eyes promptly and thoroughly with water. Get medical attention.</p>
Naphtha TTN 97 TTY1GRA	<p>Flammable. Avoid open flames and sparks.</p> <p>Use in well-ventilated area.</p> <p>Avoid contact with skin. Wear protective clothing (rubber gloves, apron, and safety goggles).</p> <p>Avoid contact with eyes. Do not wear contact lenses when working with this material. Wear safety goggles.</p> <p>Avoid swallowing.</p> <p>Get medical attention immediately.</p>	<p>Use CO₂ or dry chemical extinguisher.</p> <p>Remove victim to fresh air. If breathing has stopped, perform artificial respiration. Get medical attention.</p> <p>Wash skin promptly and thoroughly with soap or mild detergent and water. If irritation persists after washing, get medical attention.</p> <p>Flush eyes promptly and thoroughly with water. Get medical attention.</p> <p>Do not induce vomiting. Get medical attention.</p>

Insert the latest changed pages in accordance with the instructions on the transmittal sheet.

LIST OF EFFECTIVE PAGES

NOTE: On a changed page, the portion of the text affected by the change is indicated by a vertical line in the outer margin of the page. Changes to illustrations are indicated by a letter suffix adjacent to the identification number. Added or completely revised chapters, sections, paragraphs, tables, etc. , are indicated by a vertical line by the title.

Dates of issue for original and changed pages are:

Original..0....24 Jul 79 Change...5...31Aug81 Change ..10....9 Ju1 86
 Change..1....17 Sep 79 Change...6...17 Feb 82 Change 11...16 Dec 87
 Change..2....29 Nov 79 Change...7...23Nov 82 Change 12...20 Feb 89
 Change..3....8 Sep 80 Change...8...30 Jun 83 Change 13...21 Feb 90
 Change..4....12Mar 81 Change...9...15 Sep 84 Change 14...10 Jul 92

THIS MANUAL CONTAINS INTENTIONALLY UNNUMBERED BLANK PAGES.
 TOTAL NUMBER OF PAGES IN THIS PUBLICATION IS 512 CONSISTING OF THE FOLLOWING:

Page No.	* Change No.	Page No.	* Change No.	Page No.	* Change No.
a	12	2-39	0	2-90	0
b	10	2-40	10	2-91	11
c	10	2-41	0	2-93	0
d	10	2-42	0	2-95	11
e	12	2-43	11	2-97	0
f				10	2-44 0
	2-99	0			
A	14	2-45	7	2-101	0
B	14	2-475	11	2-103	0
i	13	2-49	10	2-105	0
ii	14	2-51	0	2-107	0
iii	13	2-53	10	2-108	0
iv	14	2-55	0	2-109	0
1-1	13	2-57	11	2-111	0
2-1	0	2-58	0	2-113	0
2-3	0	2-59	11	2-115	0
2-5	0	2-61	0	2-117	0
2-7	7	2-62	7	2-119	0
2-9	10	2-63	0	2-121	0
2-11	11	2-65	10	2-123	0
2-13	11	2-67	0	2-125	0
2-15	0	2-69	0	2-127	0
2-17	0	2-71	0	2-129	0
2-19	4	2-73	0	2-131	0
2-21	0	2-75	11	2-133	0
2-23	0	2-77	0	2-134	0
2-25	0	2-78	13	2-135	0
2-27	0	2-79	4	2-137	0
2-29	13	2-81	0	2-139	0
2-31	11	2-83	0	2-141	14
2-33	0	2-85	0	2-143	0
2-35	9	2-87	0	2-144	0
2-37	7	2-88	0	2-145	0
2-38	0	2-89	0	2-147	0

*Zero in this column indicates an original page.

LIST OF EFFECTIVE PAGES - Continued

Page No.	* Change No.	Page No.	* Change No.	Page No.	* Change No.
2-148	0	3-27	8	3-85	0
2-149	10	3-29	8	3-86	5
2-150	4	3-31	8	3-87	0
2-151	4	3-33	0	3-88	0
2-153	4	3-35	0	3-89	4
2-155	9	3-37	0	3-91	0
2-157	9	3-39	0	3-92	0
2-159	4	3-41	0	3-93	0
2-161	4	3-43	0	3-94	0
2-163	4	3-45	8	3-95	0
2-165	4	3-47	13	3-96	0
2-167	0	3-49	13	3-96.1	12
2-168	0	3-51	5	3-97	12
2-169	0	3-53	9	3-98	0
2-171	0	3-54	11	3-99	0
2-173	11	3-55	11	3-100	0
2-174	9	3-56	10	3-101	0
2-175	0	3-57	0	3-102	4
2-177	10	3-58	0	3-103	0
2-178	5	3-59	11	3-104	0
2-179	4	3-60	10	3-105	9
2-180	0	3-61	10	3-106	5
2-181	0	3-62	11	3-107	0
2-182	0	3-63	0	3-108	0
2-183	0	3-64	0	3-109	4
2-184	7	3-64.1	11	3-110	0
2-185	0	3-65	11	3-111	11
2-186	4	3-66	0	3-113	10
2-187	4	3-67	0	3-114	11
2-188	4	3-68	10	3-115	0
2-189	4	3-69	0	3-116	0
2-190	4	3-70	10	3-117	11
3-1	9	3-71	0	3-119	11
3-3	0	3-72	4	3-120	0
3-5	0	3-73	0	3-121	0
3-6	0	3-74	0	3-122	9
3-7	0	3-75	0	3-122.1	10
3-9	0	3-76	0	3-123	10
3-11	0	3-77	7	3-124	0
3-13	0	3-78	10	3-125	0
3-15	8	3-79	4	3-126	8
3-17	8	3-80	0	3-127	8
3-19	0	3-81	0	3-128	0
3-21	0	3-82	0	3-129	8
3-23	0	3-83	10	3-130	8
3-25	8	3-84	9	3-131	8

*Zero in this column indicates an original page.

LIST OF EFFECTIVE PAGES - Continued

Page No.	* Change No.	Page No.	* Change No.	Page No.	* Change No.
3-132	10	3-180	0	3-227	9
3-133	8	3-181	0	3-229	0
3-134	8	3-182	0	3-230	0
3-135	14	3-183	0	3-231	0
3-136	14	3-184	0	3-232	0
3-137	8	3-185	0	3-233	0
3-138	0	3-186	0	3-234	5
3-139	0	3-187	0	3-234.1	13
3-140	0	3-188	0	3-235	0
3-141	0	3-189	0	3-236	0
3-142	0	3-190	0	3-237	0
3-143	8	3-191	0	3-238	0
3-144	8	3-192	0	3-239	0
3-145	8	3-193	0	3-240	0
3-146	8	3-194	5	3-241	0
3-147	0	3-195	0	3-242	0
3-148	8	3-196	0	3-243	0
3-149	8	3-197	0	3-244	0
3-150	8	3-199	0	3-245	0
3-151	8	3-200	0	3-246	0
3-152	0	3-201	0	3-247	9
3-153	8	3-202	0	3-248	9
3-154	8	3-203	0	3-249	0
3-155	8	3-204	0	3-250	0
3-157	8	3-205	0	3-251	0
3-158	8	3-206	0	3-252	0
3-159	8	3-207	0	3-253	0
3-160	5	3-208	0	3-255	0
3-161	0	3-209	0	3-256	9
3-162	10	3-210	0	3-256.1	9
3-163	5	3-211	0	3-257	0
3-164	4	3-212	0	3-259	0
3-165	0	3-213	0	3-261	0
3-166	0	3-214	0	3-262	0
3-167	11	3-215	0	3-263	0
3-169	11	3-216	0	3-265	0
3-170	0	3-217	0	3-267	0
3-171	0	3-218	0	3-269	0
3-172	0	3-219	0	3-270	0
3-173	7	3-220	0	3-271	0
3-174	10	3-221	0	3-273	0
3-175	10	3-222	0	3-275	0
3-176	10	3-223	0	3-276	0
3-177	0	3-224	0	3-277	7
3-178	0	3-225	0	3-279	7
3-179	14	3-226	0	3-280	0

*Zero in this column indicates an original page.

LIST OF EFFECTIVE PAGES - Continued

Page No.	* Change No.	Page No.	* Change No.	Page No.	* Change No.
3-281	0	3-338	0	3-391	9
3-282	0	3-339	7	3-393	10
3-283	0	3-340	0	3-395	9
3-285	0	3-341	0	3-397	9
3-287	0	3-343	0	3-399	10
3-289	0	3-344	0	3-401	9
3-291	0	3-345	0	3-403	0
3-292	0	3-347	4	3-404	12
3-293	0	3-348	0	3-404.1	12
3-295	0	3-349	0	3-404.3	12
3-296	0	3-350	12	3-404.4	12
3-297	0	3-351	12	3-405	12
3-299	0	3-352	0	3-407	12
3-300	0	3-353	0	3-408	0
3-301	0	3-355	0	3-409	12
3-303	0	3-356	0	3-410	14
3-305	0	3-357	5	3-411	14
3-306	0	3-358	0	3-413	9
3-307	0	3-359	0	3-415	9
3-308	0	3-360	0	3-417	14
3-309	0	3-361	0	3-419	9
3-311	0	3-362	0	3-421	9
3-312	0	3-363	0	3-422	12
3-313	0	3-364	0	3-423	14
3-315	0	3-365	0	3-425	11
3-316	8	3-366	7	3-427	11
3-317	8	3-367	7	3-429	14
3-318	0	3-368	7	3-431	11
3-319	0	3-369	9	3-433	11
3-320	8	3-370	7	3-435	14
3-321	8	3-371	8	3-436	14
3-322	0	3-372	0	3-436.1	14
3-323	0	3-373	0	3-436.3	14
3-324	8	3-375	0	3-436.5	14
3-325	8	3-377	0	3-436.7	14
3-326	0	3-378	1	3-436.9	14
3-327	0	3-379	1	3-436.11	14
3-328	0	3-381	1	3-436.13	14
3-329	0	3-382	0	3-436.14	14
3-330	0	3-383	0	3-437	12
3-331	0	3-384	0	A-1	0
3-332	0	3-385	0	B-1	14
3-333	0	3-386	0	C-1	0
3-335	0	3-387	0	C-2	0
3-336	0	3-388	10	C-3	0
3-337	0	3-389	10		

*Zero in this column indicates an original page.

TECHNICAL MANUAL

No. 9-4935-1540-14-2

HEADQUARTERS
DEPARTMENT OF THE ARMY
Washington, D.C., 24 July 1979

CHAPTER

**OPERATOR, ORGANIZATIONAL, DIRECT SUPPORT AND
GENERAL SUPPORT MAINTENANCE MANUAL
SCHEMATICS FOR
GUIDED MISSILE REMOTE CONTROL SYSTEM SHOP EQUIPMENT
AN/TSM-104 4935-01-051-8691 (SHOP 3), AN/TSM-105 4935-00-782-1957 (MTS),
AN/TSM-179 4935-01-218-7089 (SHOP 1) *(AQ)¹,
AN/TSM-146 4935-01-083-3129 (SHOP 1) *(AP)¹,
AN/TSM-169 4935-01-166-2185 (SHOP 2),
AN/TSM-177 4935-01-223-9088 (SHOP 9) *(AQ)¹,
AN/TSM-145 4935-01-085-5618 (SHOP 9) *(AP)¹,
AND SUPPLEMENTARY EQUIPMENT GUIDED MISSILE TEST STATION
AN/TSM-180 4935-01-223-9122 (TAG) *(AQ)¹,
AN/TSM-148 4935-01-085-5679 (TAG) *(AP)¹
HAWK AIR DEFENSE GUIDED MISSILE SYSTEM**

REPORTING ERRORS AND RECOMMENDING IMPROVEMENTS

You can help improve this manual. If you find any mistakes or if you know of a way to improve the procedures, please let us know. Mail your letter, DA Form 2028 (Recommended Changes to Publications and Blank Forms) direct to: Commander, U. S. Army Missile Command, ATTN: AMSMI-MMC-ME-P, Redstone Arsenal, AL 35898-5238. Areply will be furnished to you.

TABLE OF CONTENTS

CHAPTER Section	1. INTRODUCTION.....	Paragraph	Page
	I. General		
	Scope.....	1-1	1-1
	Forms, records and reports	1-2	1-1
	Reporting equipment improvement recommendations (EIRs)	1-3	1-1
	II. Explanation of coverage		
	Interconnecting diagrams	1-4	1-1
	Unit schematics	1-5	1-1
	Deleted	1-6	1-1
	Reference designations	1-7	1-1
	Nominal values	1-8	1-1
	Functional group codes	1-9	1-1
	High-frequency console modules	1-10	1-1
	Differences among models	1-11	1-1
	Electrostatic discharge sensitive items	1-12	1-1

¹Refer to appendix B for serial number effectivity.

2. HIGH-FREQUENCY CONSOLE 10182561 DIAGRAMS AND SCHEMATICS	Figure	Page
High-frequency console 10182561 (FG 3000).....	2-1	2-1
Amplifier-indicator 10676983 (A66) (FG 4000)	2-2	2-38
Electrical equipment drawer 11569991 (A82)	2-2.1	2-40
Relay assembly group (range program) 10670666 (A2) (FG 4620)	2-3	2-41
Console control 10676000 (A81) (FG 6200)	2-4	2-42
Variable transformer control A81A2 10671085, variable transformer drive A47 10671084 and variable power transformer A47 10675175.....	2-5	2-43
50-MHz counter 10175952 (A57) (FG 4400)	2-6	2-44
Dual-pulse generator 10182657 (A65) (FG 5200)	2-7	2-58
Multi-function generator 10182653 (A67) (FG 4000)	2-8	2-62
Digital multimeter B 11569529 (A58) (FG 4800)	2-9	2-78
Digital multimeter A 11569529 (A60) (FG 4800)	2-11	2-89
Oscilloscope subassembly 10674937 (A61A1) (FG 5050)	2-12	2-90
Oscilloscope vertical amplifier 10674938 (A61A2) (FG 5100)	2-13	2-108
Oscilloscope sweep generator 10674939 (A61A3) (FG 5150)	2-14	2-134
Power supply control 10670972 (A59) (FG 7450)	2-15	2-144
Master program board	2-16	2-148
Programmer 10670685 (A77) (FG 6450)	2-17	2-150
Signal generator 10182039 (A69) (FG 3800)	2-18	2-168
Thermal-noise generator 10182651 (A68) (FG 3600)	2-19	2-173
3.0/6.0-Vdc power supply 10182658 (A62) (FG 5600)	2-20	2-174
26-Vdc power supply 10180942 (A38) (FG 6000)	2-21	2-178
28-Vdc power supply 9188025 (A37) (FG 3200)	2-22	2-179
102-Vdc power supply 10110081 (A24, A25) (FG 5400)	2-23	2-180
150/200-Vdc power supply 10110015 (A28, A31, A32, A33, A34) (FG 3400) ..	2-24	2-182
260/300-Vdc power supply 10110086 (A29, A30, A35) (FG 5800)	2-24	2-182
Four-output power supply 10175776 (A48, A55) (FG 4200)* (L)I	2-26	2-186
Four-output power supply 10175776 (A48, A55) (FG 4200)* (K)1	2-27	2-188
Power supply subassembly (AI) 10176670 (FG 4275)* (K)I	2-28	2-190
3. SHOP AND CONSOLE ACCESSORIES SCHEMATICS		
I. Test leads and cables		
Test leads	3-1	3-1
Test cables	3-2	3-6
II. Patchboards		
Pb BCC-402A 10104979 (FG 1010)	3-3	3-54
Pb BCC-404 9195670 (FG 1090).....	3-4	3-55
Pb BCC-406B 11568007 (FG 1015)	3-5	3-56
Pb BCC-413/422A 10175142 (FG 1020)	3-6	3-57
Pb BCC-417B 10673424 (FG 1025)	3-7	3-58
Pb BCC-421 9195678 (FG 1095).....	3-8	3-59
Pb BCC-423, 9195679 (FG 1030)	3-9	3-60
Pb BCC-429A 9166733 (FG 1035)	3-10	3-61
Pb BCC-435 9196543 (FG 1040)	3-11	3-62
Pb BCC-451A 10675081 (FG 1045)	3-12	3-63
Pb BCC-482A 10177210 (FG 1050)	3-13	3-64
Pb BCC-484 9195690 (FG 1055)	3-14	3-65
Pb BCC-486A 10675764 (FG 1060)	3-15	3-66
Pb BCC-487C 10105101 (FG 1065)	3-16	3-67
Pb BCC-491 9195697 (FG 1070) *(AG) ¹	3-17	3-68
Pb BCC-492A 10671756 (FG 1075)	3-18	3-69
Pb BCC-493 9195699 (FG 1080)	3-19	3-70
Pb BCC-495B 10175145 (FG 1100)	3-20	3-71
Pb BCC-501 10110909 (FG 1085)	3-21	3-72
Pb BCC-503 10110936 (FG 1580)	3-22	3-73
Pb BCC-596A 10675945 (FG 1650)	3-23	3-74
Pb BCC8-101A 11566007 (FG 1585)	3-24	3-75
Pb BCC8-102 10670908 (FG 1590)	3-25	3-76
Pb BCC8-103 10671754 (FG 1595)	3-26	3-77
Pb BCC8-104A 11566008 (FG 1600)	3-27	3-78
Pb BCC8-105A 11569625 (FG 1605)	3-28	3-79
Pb BCC8-106 10671284 (FG 1610)	3-29	3-80

Section	Figure	Page
Pb BCC8-107 10671173 (FG 1615)	3-30	3-81
Pb BCC8-1012 10671755 (FG 1620)	3-31	3-82
Pb BCC8-1013A 11568008 (FG 1625)	3-32	3-83
Pb BCC8-1014 10670270 (FG 1630)	3-33	3-84
Pb BCC8-1015 10670262 (FG 1635)	3-34	3-85
Pb BCC8-1016A 11566009 (FG 1640)	3-35	3-86
Pb BCC8-1018 10671758 (FG 1645)	3-36	3-87
Pb COMMO8-101 10675324 (FG 1735)	3-37	3-88
Pb COMMOS-102B 10288566 (FG 1740)	3-38	3-89
Deleted	3-39	3-90
Pb CWR-432 9195750 (FG 1110)	3-40	3-91
Pb CWR-435A 10670540 (FG 1115)	3-41	3-92
Pb CWR-462B 10676866 (FG 1120)	3-42	3-93
PB CWR-463A 10179011 (FG 1125)	3-43	3-94
Pb CWR8-102 10670530 (FG 1655)	3-44	3-95
Pb CWRS-103 10670258 (FG 1660)	3-45	3-96
Pb CWR8-107A 13233649* (AQ) ¹ (FG 1670)	3-45.1	3-96.1
Pb CWR-107 10670245* (AP) ¹ (FG 1670)	3-46	3-97
Pb CWRS-108 10671589 (FG 1675)	3-47	3-98
Pb CWR8-109 10670249 (FG 1680)	3-48	3-99
Pb CWR-1010 10671625 (FG 1685)	3-49	3-100
Pb CWR8-1011 10671165 (FG 1690)	3-50	3-101
Pb CWRS8-10012A 11566012 (FG 1695)	3-51	3-102
Pb CWR8-1014 10671169 (FG 1705)	3-52	3-103
Pb CWR8-1015A 10291959 (FG 1105)	3-53	3-104
Pb CWR8-1017 11566013 (FG 4320)	3-54	3-105
Pb DPS-101B 11510199 (FG 1710)	3-55	3-106
Pb DP8-102A 10288586 (FG 1715)	3-56	3-107
Pb DP-103 10671161 (FG 1720)	3-57	3-108
Pb DP8-104 10671630 *(W) ¹ (PG 1725)	3-58	3-109
Pb DP8-105 10671761 (FG 1730)	3-59	3-110
Deleted	3-60	3-111
Pb HPAR-406 9195704 (FG 1145)	3-61	3-111
Pb HPAR-408 9195705 (FG 1150)	3-62	3-113
Pb HPAR-409 9195706 (FG 1160)	3-63	3-114
Pb HPAR-410A 11566016 (FG 1165)	3-64	3-115
Pb HPAR-418B 11566015 (FG 1185)	3-65	3-116
Pb HPAR-438A 10675077 (FG 1190)	3-66	3-117
Deleted	3-67	3-118
Pb HPAR-563A 10675078 (FG 1225)	3-68	3-119
Pb HPAR-101 10675326 (FG 1140)	3-69	3-120
Pb HPAR8-102 10674864 (FG 1170)	3-70	3-122
Pb HPAR8-103A 13219772 *(AL) ¹ (FG 1195)	3-70.1	3-122.1
Pb HPARS-103 10675241 *(AK) ¹ (FG 1195)	3-71	3-123
Pb HPAR8-105 10675090 (FG 1215)	3-72	3-124
Pb HPARS 108 10675328 (FG 1235)	3-73	3-125
Pb HPI-OSOIB 10288654 *(AB) ¹ (FG 1240)	3-74	3-126
Pb HPI-502B 10173971 *(AB) ¹ (FG 1245)	3-75	3-127
Pb HPI-504A 10108023 (FG 1250)	3-76	3-128
Pb HPI-508A 10108345 *(AB) ¹ (FG 1260)	3-77	3-129
Pb HPI-509B 11566537 *(AB) ¹ (FG 1265)	3-78	3-130
Pb HPI-510B 10173976 *(AB) ¹ (FG 1270)	3-79	3-131
Pb HiPI-514 10106893 *(AB) ¹ (FG 1275)	3-80	3-132
Pb HPI-516C 10110372 *(AB) ¹ (FG 1280)	3-81	3-133
Pb HPI-517D 10173962 *(AB) ¹ (FG 1285)	3-82	3-134
Pb HPI-520B 11567799 *(AV) ¹ (FG 1290)	3-83	3-135
Pb HPI-520C 13385013 *(AW) ¹ (FG 1290)	3-84	3-136
Pb HPI-523 10174862 *(AB) ¹ (FG 1300)	3-85	3-137
Pb HPI-526 10180531 *(AB) ¹ (FG 1300)	3-86	3-138
Pb HPI7-105A 10676961 (FG 1330)	3-87	3-139
Pb HPI8-101 10670299 (FG 1755)	3088	3-140

¹Refer to appendix B for serial number effectivity.

Section	Figure	Page
Pb HPI8-102 10669304 (FG 1760)	3-89	3-141
Pb HPI8-103 10669248 (FG 1765)	3-90	3-142
Pb HPI8-104 10669197 *(AB) ¹ (FG 1770)	3-91	3-143
Pb HPI8-106 10671762 *(AB) ¹ (FG 1775)	3-92	3-144
Pb HPI8-107 10671763 *(AB) ¹ (FG 1780)	3-93	3-145
Pb HPI8-108 10671764 *(AB) ¹ (FG 1785)	3-94	3-146
Pb HPI8-109 10670449 (FG 1790)	3-95	3-147
Pb HPI8-1010A 10669031 *(AB) ¹ (FG 1795)	3-96	3-148
Pb HPI8-1011 10671766 *(AB) ¹ (FG 1800)	3-97	3-149
Pb HPI8-1012A 10669027 *(AB) ¹ (FG 1805)	3-98	3-150
Pb HPI8-1013 10671768 (FG 1810)	3-99	3-152
Pb HPI8-1015 10671769 *(AB) ¹ (FG 1820)	3-100	3-153
Pb HPI8-1016 10671605 *(AB) ¹ (FG 1825)	3-101	3-154
Pb HPI8-1017 10670298 *(AB) ¹ (FG 1815)	3-102	3-157
Pb HPI8-1018 10671770 *(AB) ¹ (FG 1850)	3-103	3-158
Pb HPI8-1019A 10288125 (FG 1255)	3-104	3-160
Pb HPI8-1020 10675898 (FG 1657)	3-105	3-161
Pb HROR-501 10042753 (FG 1305)	3-106	3-162
Pb HROR-502A 10103211 (FG 1310)	3-107	3-163
Pb HROR-503B 10111216 (FG 1315)	3-108	3-164
Pb HROR-504 10042756 (FG 1320)	3-109	3-165
Pb HROR-505 10042762 (FG 1325)	3-110	3-165
Pb HROR-506A 10103527 (FG 1330)	3-111	3-166
Pb HROR-507 10042764 (FG 1335)	3-112	3-166
Pb HROR-508A 10675080 (FG 1340)	3-113	3-167
Pb HROR-509B 10104940 (FG 1345)	3-114	3-169
Pb HROR-510B 10674587 (FG 1350)	3-115	3-170
Pb HROR-511 10042768 (FG 1355)	3-116	3-172
Pb HROR-512 10042769 (FG 1360)	3-117	3-172
Pb HROR-515 10042772 (FG 1365)	3-118	3-173
Pb HROR-516A 10103660 (FG 1370)	3-119	3-174
Pb HROR-517A 10103250 (FG 1375)	3-120	3-175
Pb HROR-518 10042784 (FG 1380)	3-121	3-176
Pb HT-501B 10173893 (FG 1385)	3-122	3-176
Pb HT-505A 10112739 (FG 1395)	3-123	3-177
Pb HT-506 10107353 (FG 1400)	3-124	3-177
Pb HT-507B 10112741 (FG 1405)	3-125	3-178
Pb HT-509A 10111392 (FG 1415)	3-126	3-179
Pb HT-510A 10675079 (FG 1420)	3-127	3-180
Pb HT-512 10109957 (FG 1425)	3-128	3-181
Pb HT-513A 10111926 (FG 1430)	3-129	3-182
Pb HT-514A 10111395 (FG 1435)	3-130	3-183
Pb HT-520A 10111931 (FG 1445)	3-131	3-184
Pb HT-522B 10112743 (FG 1450)	3-132	3-185
Pb HT-526A 10111410 (FG 1455)	3-133	3-186
Pb HT-529 10110808 (FG 1460)	3-134	3-187
Pb HT-530A 10111916 (FG 1465)	3-135	3-188
Pb HT-532A 10111921 (FG 1470)	3-136	3-189
Pb HT-533A 10111911 (FG 1475)	3-137	3-190
Pb HT-534B 10288439 (FG 1480)	3-138	3-191
Pb HT-537A 10111406 (FG 1485)	3-139	3-192
Pb HT-538A 10111398 (FG 1490)	3-140	3-193
Pb HT-540B 10173896 (FG 1495)	3-141	3-194
Pb HT-543 10110736 (FG 1500)	3-142	3-195
Pb HT-544B 10112776 (FG 1505)	3-143	3-196
Pb HT-545A 10111855 (FG 1510)	3-144	3-197
PB HT-547B 10173898 (FG 1515)	3-145	3-199
Pb HT-548A 10111378 (FG 1520)	3-146	3-200
Pb HT-550A 10173926 (FG 1525)	3-147	3-202
Pb HT-551B 10677208 (FG 1530)	3-148	3-203
Pb HT-556A 10112786 (FG 1545)	3-149	3-204
Pb HT-557A 10173933 (FG 1550)	3-150	3-205

Section	Figure	Page
Pb HT8-101 10670266 (FG 1830)	3-151	3-206
Pb HT8-104A 11566561 (FG 3870)	3-152	3-207
Pb HT8-105 10671256 (FG 1840)	3-153	3-208
Pb HT8-107 10671617 (FG 1845)	3-154	3-209
Pb HT8-109 10670291 (FG 3880)	3-155	3-210
Pb HT8-1010A 10288432 (FG 1860)	3-156	3-212
Pb HT8-1011 10671750 (FG 1865)	3-157	3-214
Pb HT8-1012 10671751 (FG 1870)	3-158	3-215
Pb HT8-1013 10670287 (FG 3890)	3-159	3-216
Pb HTS-1015 10671543 (FG 1880)	3-160	3-217
Pb HT8-1016 10671613 (FG 1885)	3-161	3-218 1
Pb HT8-1021 10670916 (FG 1895)	3-162	3-219
Pb HT8-1024A 10669023 (FG 1905)	3-163	3-220
Pb HT8-1025A 10288105 (FG 1910)	3-164	3-221
Pb HT8-1026 10671795 (FG 1915)	3-165	3-222
Pb HT8-1027 10671688 (FG 1920)	3-166	3-223
Pb HT8-1028B 10288276 (FG 1925)	3-167	3-224
Pb HT8-1029A 10288830 (FG 1945)	3-168	3-226
Pb HT8-1030A 10288279 (FG 1900)	3-169	3-227
Pb HT8-1031 11569535 (FG 3875)	3-170	3-229
Pb L8-104A 10287985 (FG 1930)	3-171	3-230
Pb L8-105 10670535 (FG 1935)	3-172	3-232
Pb L8-106 10675513 (FG 1967)	3-173	3-233
Pb OME8-103A *(AR)' 10287982 (FG 1940)	3-174	3-234
Pb OME8-103B *(AS)' 13234294 (FG 1940)	3-174.1	3-234.1
Pb PCP9-106 10288206 (FG 4200)	3-175	3-235
Pb SPHL7-101A 10176923 (FG 1560)	3-176	3-236
Pb SPHL7-103A 1013600 (FG 1745)	3-177	3-237
Pb SPHL7-104A 10175007 (FG 1570)	3-178	3-238
Pb SPHL7-106A 10183573 (FG 1575)	3-179	3-239
Pb SC-101 10671771 (FG 1950)	3-180	3-240
Pb SC8-102 10671772 (FG 1955)	3-181	3-242
Pb SC8-10:3 10670597 (FG 1960)	182	3-244
Pb SC8-104 10671609 (FG 1965)	3-183	3-245
Pb SC8-105 10671773 (FG 1500)	3-184	3-246
III. Accessories		
BSM terminations 51 ohm 10067063-1, 100 ohm 10067063-2, 1000 ohm 10067063-3, and 75 ohm 10067063-4	3-184.1	3-247
Test adapter (41 pin card extender) 11566544	3-185	3-247
Test adapter (29 pin card extender) 11566409	3-186	3-247
Test adapter (wired circuit module) 10112031	3-187	3-248
Test adapter TA8-103 106770 7 4 8	3-188	3-248
Test adapters TA-104 10670746, TA8-105 10670747-2, TAS-106 10670747-1, TA8-107 10670747-3	3-189	3-248
Test adapter TA81010 10671774	3-190	3-248
Test adapter TA8-1014 10180726	3-191	3-249
Test adapter TA8-1017 10675343 (FG 3820)	3-192	3-249
Test adapter TA8-1018 (air cooler adapter) 10676444 (FG 3825)	3-193	3-249
Test adapter TA8-1019 10672246	3-194	3-249
Test adapter TA8-1020 (air cooler adapter) 10676869 (FG 3830) 0	3-195	3-249
Test adapter TA8-1021 10292827 (FG 4210)	3-196	3-250
Test adapter TAS-1022 1156593 FG 4300)	3-197	3-252
Test adapter TA8-1023 11566026 (FG 4360)	3-198	3-253
Test adapter TA8-1024 11566020 (P/O FG 4400)	3-199	3-255
Test adapter TA8-1028 11570851 (FG 1100)	3-199.1	3-256
Test adapter TA8-1029 11570883 (P/O FG 4380)	3-199.2	3-256
Test fixture TF8-103 (universal load box) 10671776 (FG 3660)	3-200	3-256.1
Test fixture TF8-106A (synchro test set) 11565960 (FG 3680)	3-201	3-262

¹ Refer to appendix B for serial number effectivity.

Section	Figure	Page
Test fixture TF8-106 W1 test cable	3-202	3-269
Test fixture TF8-109 10671070 (FG 3700)	3-203	3-270
Test fixture TF8-1011 10671777 (FG 3740)	3-204	3-275
Test fixture TF8-1013 (electronic switch group) 10675949 (FG 3845)	3-205	3-276
Test fixture TF8-1014A (rf power test set group) 10669035 (FG 3835)	3-206	3-280
Test fixture TF8-1016 10677234 (FG 3900)	3-207	3-282
Test fixture TF8-1016 test cables	3-208	3-292
Test control group 10677611 (A1) (FG 3970)	3-209	3-296
Test adapter servomechanism 10677593 (A1A1) (FG 3980)	3-210	3-299
Rotary switch assembly 10677606 (A1A2)	3-211	3-300
Test fixture TF8-1017 10288325 (FG 4200)	3-212	3-306
Unit adapter UA7-1024 10180021 (FG 2960)	3-213	3-307
Unit adapter UA8-104 10674586 (FG 3000)	3-214	3-308
Unit adapter UA8-105 10671779 (FG 3020)	3-215	3-309
Unit adapter UA8-1022B 10291956 (FG 3040)	3-216	3-311
Unit adapter UA8-1034 10670671 (FG 3060)	3-217	3-312
Unit adapter UA8-1035 10670897 (FG 3080)	3-218	3-315
Unit adapter UA8-1036 10671781 *(AB) ¹ (FG 3100)	3-219	3-316
Unit adapter UA8-1037 10670893 (FG 3120)	3-220	3-318
Unit adapter UA8-1038 10671280 (FG 3140)	3-221	3-319
Unit adapter UA8-1040 10671782 *(AB) ¹ (FG 3160)	3-222	3-320
Unit adapter UA8-1043A 10288116 (FG 3200)	3-223	3-322
Unit adapter UA8-1044 10670521 *(AB) ¹ (FG 3220)	3-224	3-324
Unit adapter UA8-1045 10670511 (FG 3240)	3-225	3-326
Unit adapter UA8--1048 10670615 (FG :3280)	3-226	3-328
Unit adapter UAS-1049 10670515 (FG 3300)	3-227	3-330
Unit adapter UA8-1050A 10669039 (FG 1584)	3-228	3-332
Unit adapter UA8-1051 10670855 (FG 3340)	3-229	3-335
Unit adapter UA8-1052B 10288587 (FG 3360)	3-230	3-336
Unit adapter UA8-1053B 10288588 (FG 3380)	3-231	3-338
Unit adapter UA8-1055 10671786 (FG 3400)	3-232	3-340
Unit adapter UA8-1056 10671787 (FG 3420)	3-233	3-341
Unit adapter UA8-1057A 10288119 (FG 3440)	3-234	3-343
Unit adapter UA8-1058 10671788 (FG 3460)	3-235	3-344
Unit adapter UA8-1059 10671639 *(W)' (FG 3480)	3-236	3-347
Unit adapter UA8-1060 10671789 (FG 3560)	3-237	3-348
Unit adapter UA8-1061A 13233569 (AQ) ¹	3-237.1	3-350
Unit adapter UA8-1061 10671790* (AP) ¹	3-238	3-351
Unit adapter UA8-1062 10675083 (FG 2980)	3-239	3-352
Unit adapter UA8-1064 10671791 (FG 3600)	3-240	3-355
Unit adapter UA8-1065 10671822 (FG 3620)	3-241	3-356
Unit adapter UA8-1066 10675321 (FG 3180)	3-242	3-358
Unit adapter UA8-1067 10675329 (FG 3500)	3-243	3-360
Unit adapter UA8-1069 10675245 (FG 3520)	3-244	3-361
Unit adapter UAS-1070 10675330 (FG 3540)	3-245	3-362
Unit adapter UA8-1075 11566014 (FG 4340)	3-246	3-364
Antenna rotation simulator 10046996 (FG 2550)	3-247	3-366
Antenna rotation simulator 10108793 (FG 2725)	3-248	3-366
Auxiliary power transformer 10066907 FG 2600)	3-249	3-367
Blower assembly 9187123 (FG 2325)	3-250	3-367
Coaxial termination box 9188871 (FG 0100)	3-251	3-367
Low-voltage dummy load 10107545 (FG 1320)	3-252	3-367
Ac-dc power source 10178633 (P/O FG 2900)	3-253	3-368
Calibrator standard 10178692 (FG 2900)	3-254	3-370
Mixer simulator 10104984 (FG 2650)	3-255	3-371
Network crystal simulator 10107073 (FG 0100)	3-256	3-371
Phase modulator simulator 11009986 *(AB)' (FG 2800)	3-257	3-371
Deleted	3-258	3-371
Radar target simulator 10045265 (FG 2360)	3-259	3-372
Transformer test set 10674766 (FG 2880)	3-260	3-377
Transmitter synchro calibrator assembly 10110818 (FG 0100)	3-261	3-377

Section		Figure	Page	
IV.	Power supply test set 10180927 (FG 1300)			
	Distribution box-dummy load 11566717 *(T)1.10676830 *(R) ¹ (FG 1340)	3-262	3-378	
	High-voltage shutoff control 10180400 (AI) (P/O FG 1340)	3-263	3-382	
	Relay electric control 10180277 (A2) (P/O FG 1340)	3-264	3-382	
	Ripple measurement amplifier 10180505 (A3) (P/O FG 1340)	3-265	3-383	
	Line voltage rate of change detector 10180288 (A4) (P/O FG 1340)	3-266	3-384	
	Line voltage level detector 10180406 (A5) (P/O FG 1340).....	3-267	3-384	
	Relay assembly 10180293 (A6) (P/O FG 1340)	3-268	3-384	
	Self-test control 10180511 (A7) (P/O FG 1340)	3-269	3-385	
	Test adapter, 15-point 10180555	3-270	3-386	
	Test adapter, 25-point 10180513	3-271	3-386	
	Power supply test set test cables	3-272	3-387	
	V.	Power supply test set TF8-1019		
		Power supply test set TF8-1019 11571393 (FG 4400)	3-273	3-388
		Test cables	3-274	3-403
VI.	Calibration test set TFS-1020			
	Calibration test set TF8-1020 13233663* (AQ) ¹ (FG 4380)	3-274.1	3-404	
	Calibration test set TF8-1020 11570924* (AP) ¹ (FG 4380)	3-275	3-404.4	
	Amplifier-filter 11566028 (A4) (FG 4385)	3-276	3-408	
	Calibration test set TF8-1020 test cables	3-277	3-409	
VII.	High voltage regulator test set TF8-1021			
	High voltage regulator test set TF8-1021 11570859 *(AE)', *(AT)', *(AU)', (AV)' (FG 1000)	3-278	3-410	
	High-voltage regulator test set TF8-1021 13234185 *(AM)', *(AT)', *(AU)', *(AV)' (FG 1000)	3-279	3-422	
	High-voltage regulator test set TF8-1021 13384971 *(AW)' (FG 1000)	3-279.1	3-436	
VIII.	High voltage power supply test set TF8-1022			
	13234179 *(AM)' (FG 1200)	3-280	3-436.14	
APPENDIX	A. REFERENCES		A-1	
	B. SERIAL NUMBER EFFECTIVITY CODE		B-1	
	C. SCHEMATIC SYMBOLS		C-1	

¹Refer to appendix B for serial number effectivity.

**CHAPTER 1
INTRODUCTION
Section I. GENERAL**

1-1. Scope

a. This technical manual (TM) contains schematics for maintenance of the electronic shops and their related equipment. It supplements the information contained in TM 9-4935-1540-14-1. It includes additional information necessary to maintain and troubleshoot the high-frequency console and shop accessories.

b. This TM is one of a series of TMs on operation, assembly and emplacement, organizational maintenance, direct and general support maintenance, and depot maintenance of the HAWK air defense guided missile system.

c. Refer to TM 9-4935-1540-14-1 for a crossreference of reference designations, TM nomenclature, functional groups, and official nomenclature.

d. The requirement for nomenclature distinction between "Basic and Improved" HAWK systems and major items is no longer applicable. Action to delete this distinctive terminology

Section II. EXPLANATION OF COVERAGE

1-4. Interconnecting Diagrams

The interconnecting diagrams in chapter 2 show the connections made to every contact of every connector within major assemblies in the highfrequency console.

1-5. Unit Schematics

Chapters 2 and 3 contain schematics of repairable units in the high-frequency console and shop and console accessories. On the schematics, switches are shown in the off position and relays are shown deenergized. Signals enter a unit on the left and leave on the right. Such signals are referenced to the connector of the next unit affecting the signal. For information concerning schematic symbols, refer to MIL-STD-15-1C.

will be taken as the respective pages of the manual are changed for other reasons.

1-2. Forms, Records, and Reports

Department of the Army forms and procedures used for equipment maintenance will be those prescribed by DA PAM 738-750, The Army Maintenance Management System (TAMMS). The DA PAM is published in the Maintenance Management UPDATE. Units may subscribe to Maintenance Management UPDATE by submitting a completed DA Form 12-13.

1-3. Reporting Equipment Improvement Recommendations (EIRs)

If your equipment needs improvement, let us know. Send us an EIR. You, the user, are the only one who can tell us what you don't like about your equipment. Let us know why you don't like the design. Tell us why a procedure is hard to perform. Put it on an SF 368 (Quality Deficiency Report). Mail it to the address stated in DA PAM 738-750. We'll send you a reply.

NOTE

Unless otherwise specified, the capacitance values given on the schematics are shown in picofarads when represented by whole numbers, and microfarads when represented by decimals. The resistance values are given in ohms.

1-6. Deleted

1-7. Reference Designations

A reference designation is a combination of letters and numbers by which any assembly, unit, or component part can be identified. Reference designations of component parts are given on the unit schematics. The complete reference designation of such a part is the reference designation of the part (shown on the schematic diagram) prefixed with the reference designation of the unit (given in the figure title). A listing of reference designations of units and assemblies in the consoles can be found in TM 9-4935-

1540-14-1. For further information concerning electrical and electronic reference designations, refer to ANSI Y32.16.

1-8. Nominal Values

On the schematic diagrams, some parts are identified NU. This indicates that the part is a nominal value component, the exact value of which is determined under unit test conditions. In most cases, a very precise value is required, but the precise value required varies from one unit to the next because of differences in circuit parameters. The precise value required is initially determined at the factory by tests performed on the unit under fixed input conditions, with the unit removed from the major item. When replacement of the part is necessary, the required value should be determined in the same manner. To facilitate servicing other parts and circuits in the unit, an average value of the nominal component is given on the schematic diagram.

1-9. Functional Group Codes

Functional group codes are provided in the table of contents and figure titles. These codes provide a crossreference between the schematic and the parts manual. Applicable parts manuals for these codes are TM 9-4935-547-24P (high-frequency console), TM 9-4935-2544-24P or TM 9-4935-1544-24P (shops 1 and 9), TM 9-4935-1545-24P (shop 2), and TM 9-4935-1546-24P (shop 3).

1-10. High-Frequency Console Modules

Refer to table 1-1 to locate modules of the high-frequency console of figure 2-1.

1-11. Differences Among Models

Any differences among models that exist in the consoles are indicated by use of part numbers or a serial number effectivity code. The serial number effectivity code is listed in appendix B. Some entries in the Table of Contents have serial number effectivity codes that reflect differences among models. In some cases, these entries contain coding for the latest configuration only, unless a major change to include a new chapter, section, paragraph, etc., has been incorporated. In this case, the Table of Contents may contain coding for both the previous and latest configuration. Within the body of the manual, and beginning with code *(AS), codes are provided for the latest configuration only. Beginning with code *(AR), all previous configuration of material will remain in its present location and will not be coded unless it appears on the same page as the latest configuration.

1-12. Electrostatic Discharge Sensitive Items

a. Circuit cards used in the HAWK system contain electrostatic discharge sensitive (ESDS) items. These items are subject to damage by static electricity and require special handling. Circuit cards must be handled according to the procedures described in the TM listed below. Failure to do so may cause damage to the ESDS items.

b. Refer to TM 9-1425-525-12-4 for information pertaining to the handling procedures for circuit cards.

Table 1-1. High-Frequency Console Modules

Module	Nomenclature	Sheet no.
A16	Electrical test panel	5
A17	Power distribution panel	2
A18	Power distribution panel	1
A20	Uut connector panel	5, 18, 19
A24	102-Vdc power supply	2
A25	102-Vdc power supply	2
A28	150/200-Vdc power supply	1
A29	260/300-Vdc power supply	2
A30	260/300-Vdc power supply	J
A31	150/200-Vdc power supply	1
A32	150/200-Vdc power supply	2
A33	150/200-Vdc power supply	2
A34	150/200-Vdc power supply	1
A35	260/300-Vdc power supply	2
A37	28-Vdc power supply	1
A38	26-Vdc power supply	2
A39	Relay transformer assembly	3, 4
A41	Terminal board assembly	7, 8
A42	Resistor assembly	17
A43	Resistor assembly	17
A44	Resistor assembly	17
A45	Resistor assembly	17
A46	Relay transformer assembly	5
A47	Transformer assembly	6
A48	Four-output power supply	12
A55	four-output power supply	10
A57	50-MHz counter	11
A58	Multimeter B	14, 16
A59	Power supply control	4, 10, 12, 13
A60	Multimeter A	14, 15
A61	Oscilloscope	14
A62	3.0/6.0-Vdc power supply	2
A65	Dual pulse generator	14
A66	Amplifier-indicator	13
A67	Multi-function generator	14
A68	Thermal noise generator	14
A69	Signal generator	14
A71	Control fuse panel	3, 13, 15, 16
A77	Programmer	2 thru 19
A79	Relay driver A	14
A80	Relay driver B	14
A81	Console control module	6
A82	Electrical equipment drawer	5

CHAPTER 2
HIGH-FREQUENCY CONSOLE 10182561 DIAGRAMS

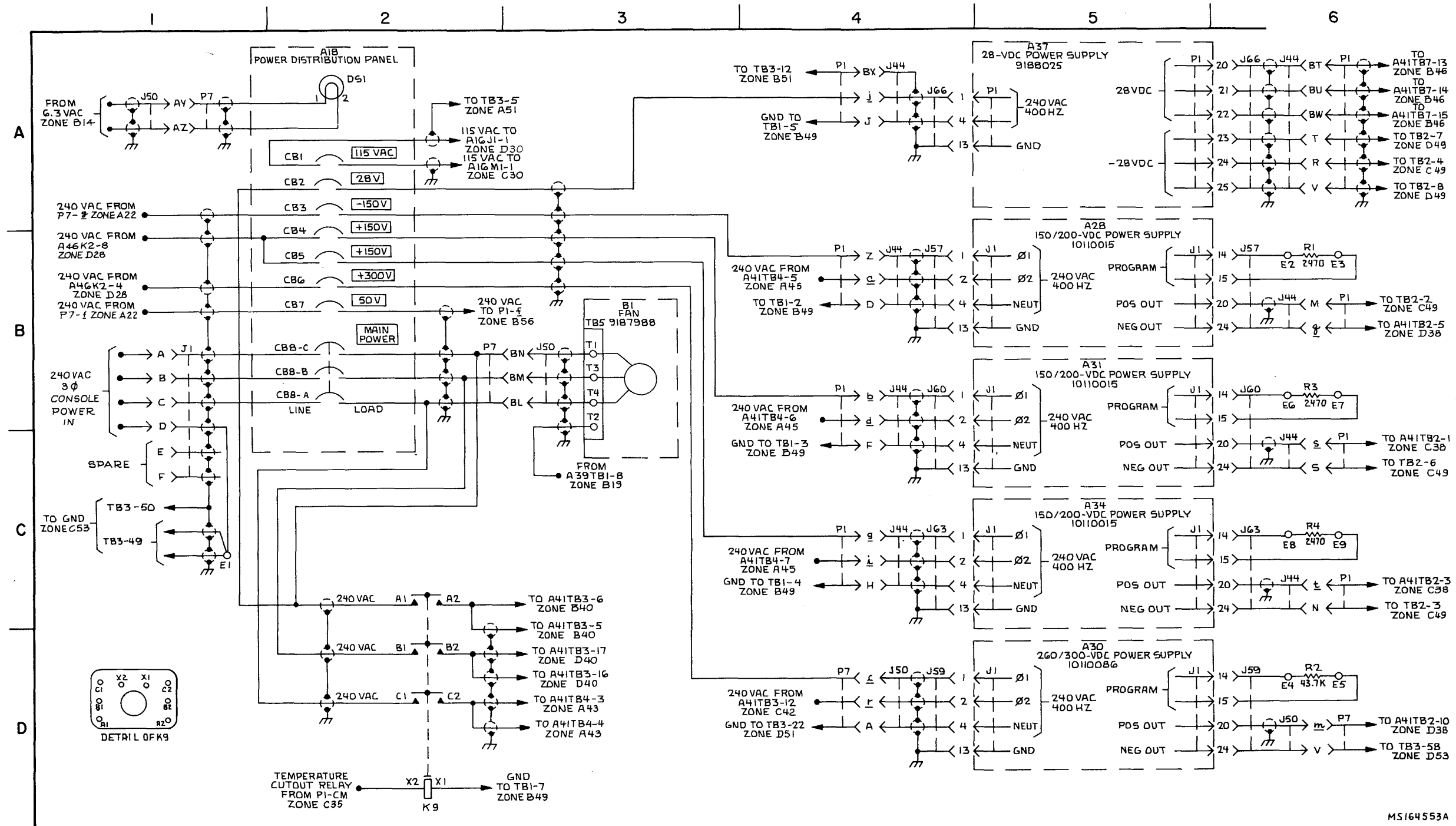

Figure 2-1. High-frequency console 10182561 (FG 3000)-interconnecting diagram (sheet 1 of 19)

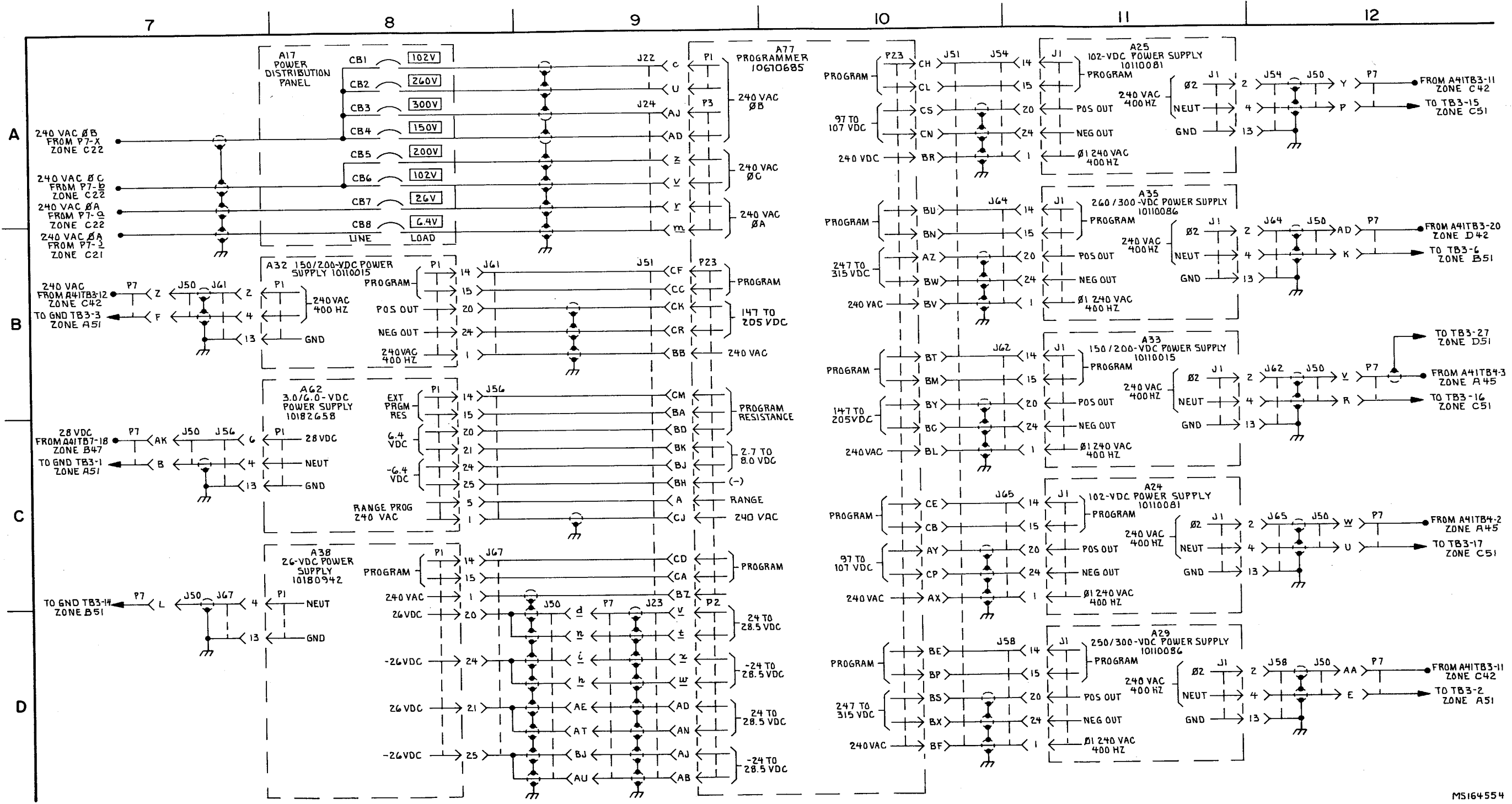
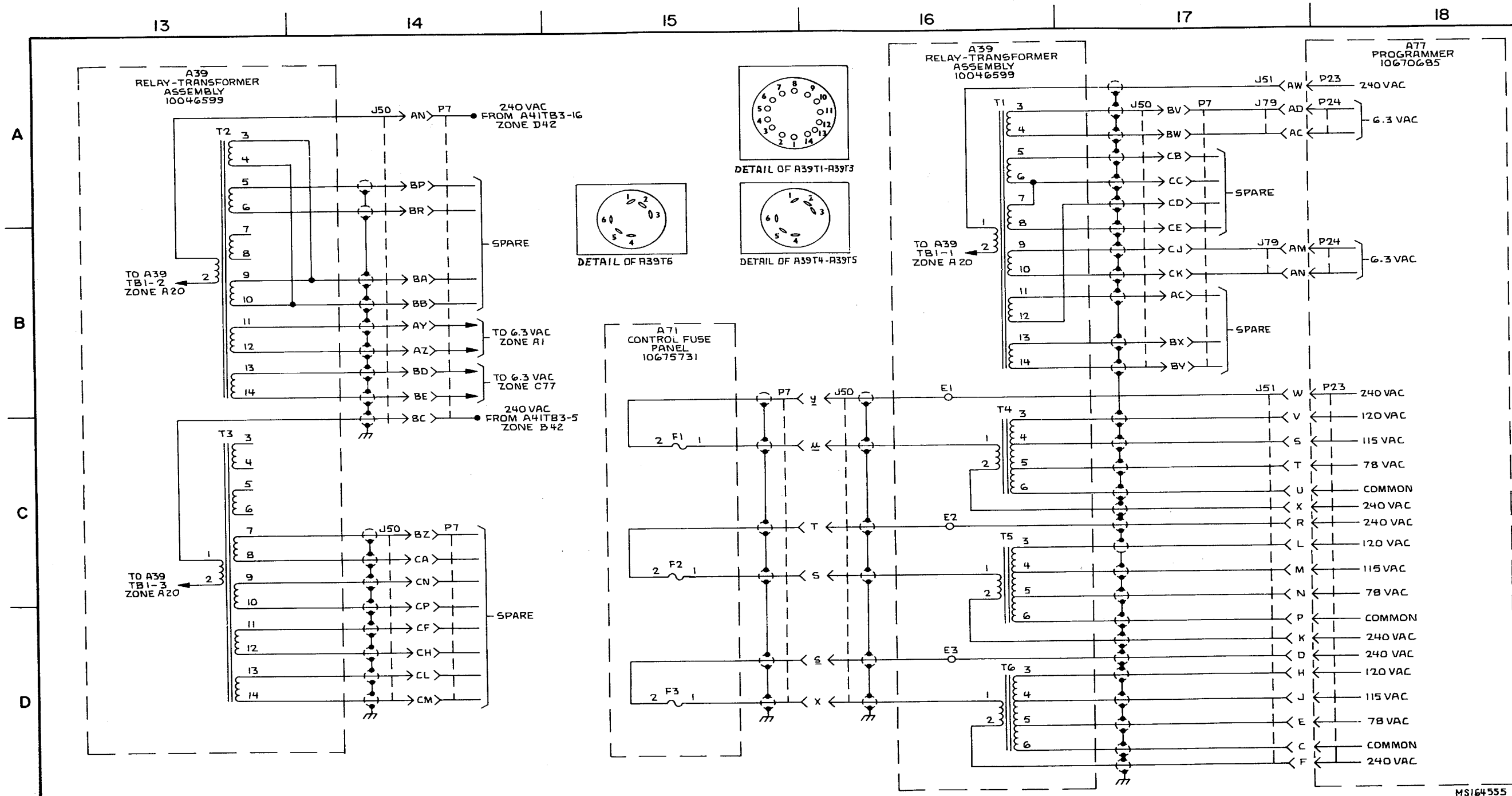

Figure 2-1. High-frequency console 10182561 (FG 3000)-interconnecting diagram (sheet 2 of 19).



MS164555

Figure 2-1. High-frequency console 10182561 (FG 3000)-interconnecting diagram (sheet 3 of 19).

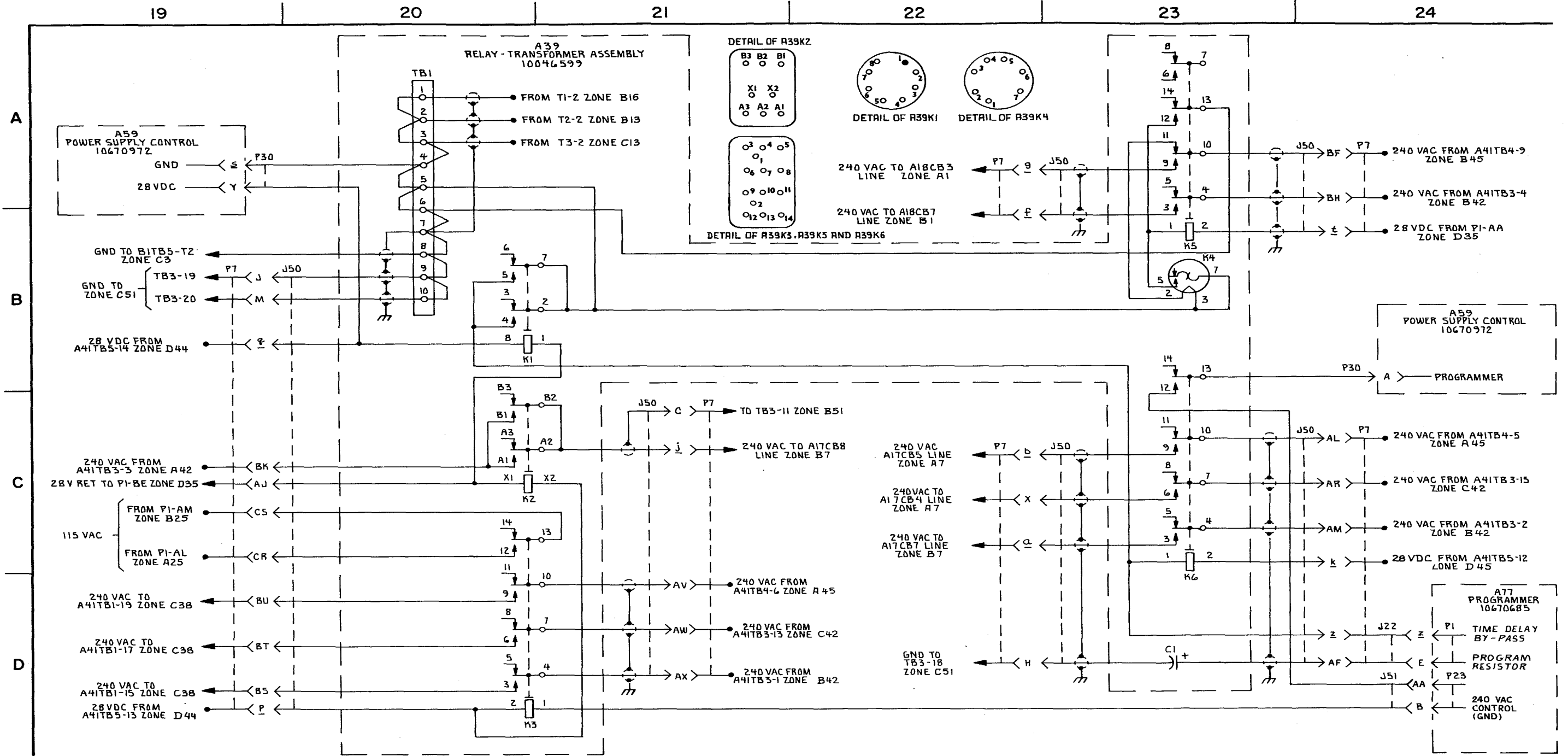

Figure 2-1. High-frequency console 10182561 (FG 3000)-interconnecting diagram (sheet 4 of 19)

MS 164556B

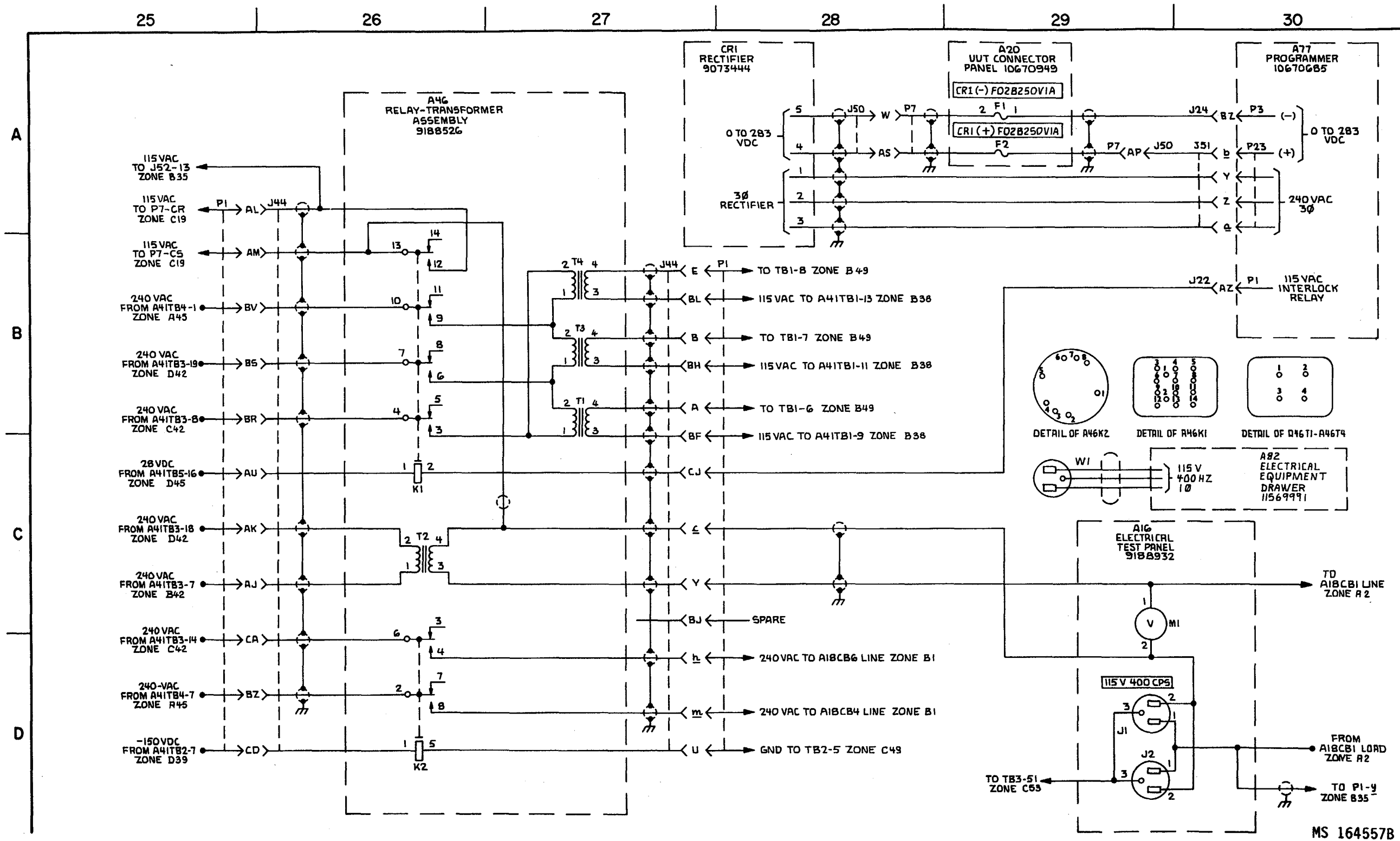
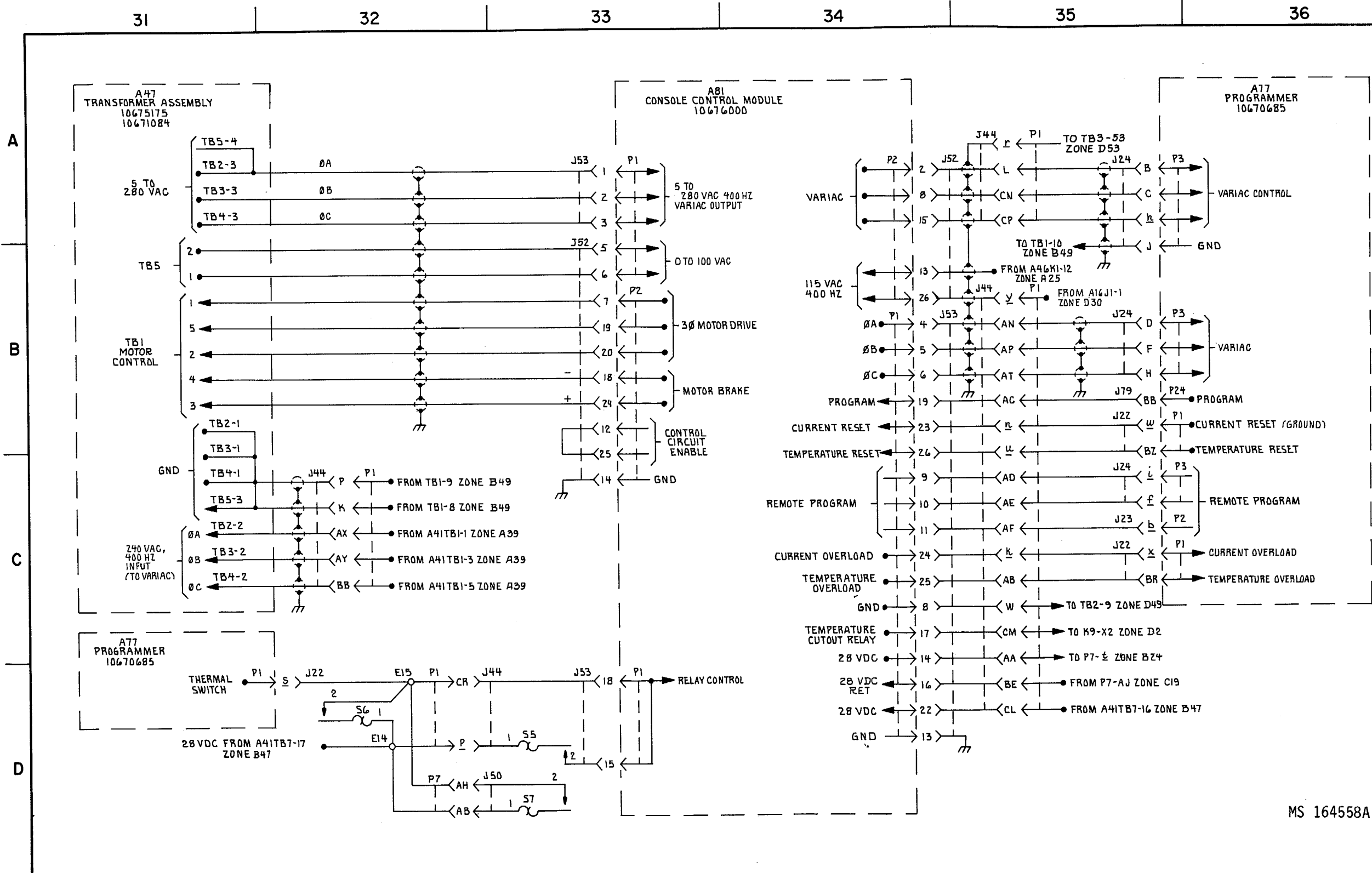
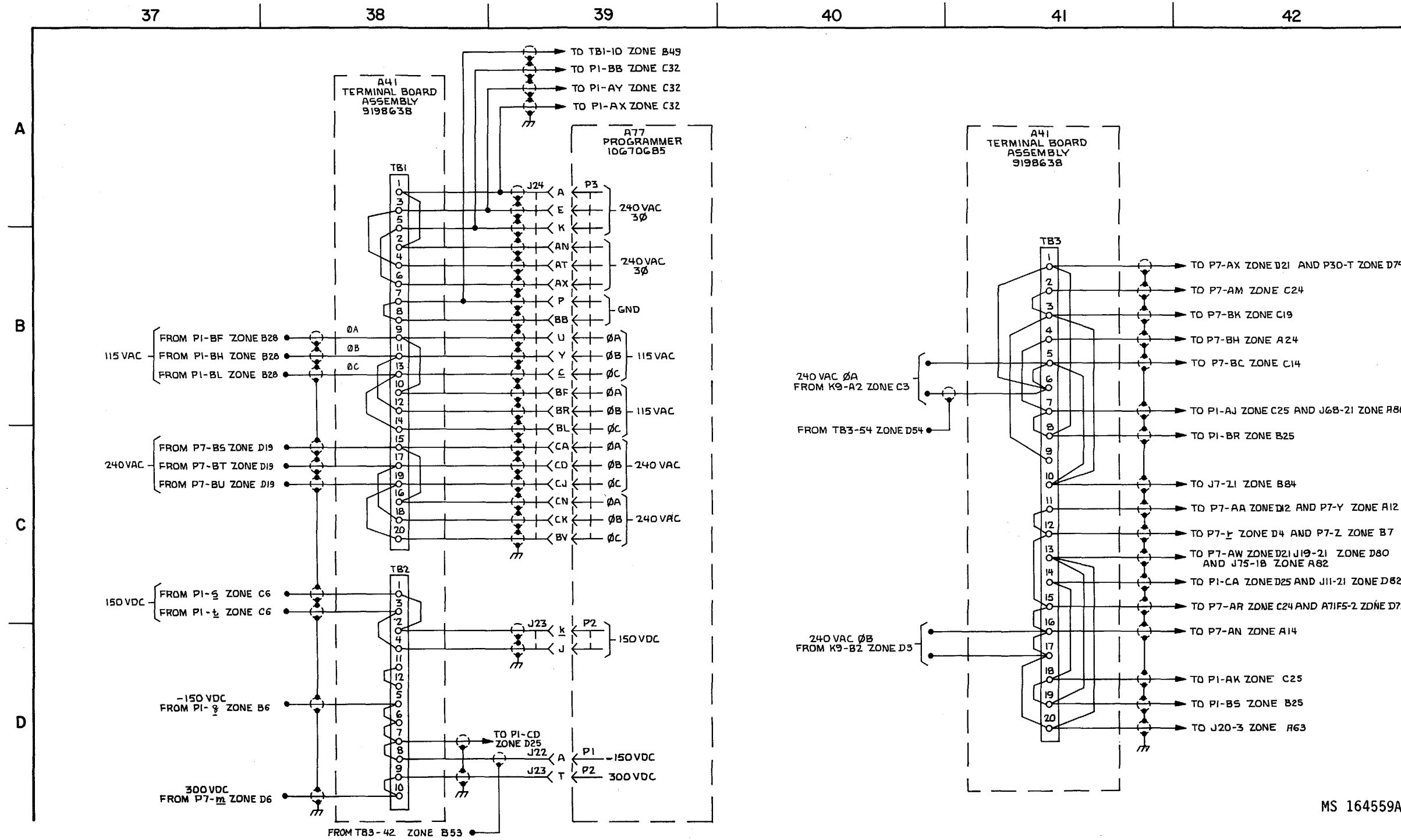

Figure 2-1. High-frequency console 10182561 (FG 3000)-interconnecting diagram (sheet 5 of 19).



MS 164558A

Figure 2-1. High-frequency console 10182561 (FG 3000)-interconnecting diagram (sheet 6 of 19).



MS 164559A

Figure 2-1. High frequency console 10182561 (FG 3000)-interconnecting diagram (Sheet 7 of 19).

2-13(2-14 blank)

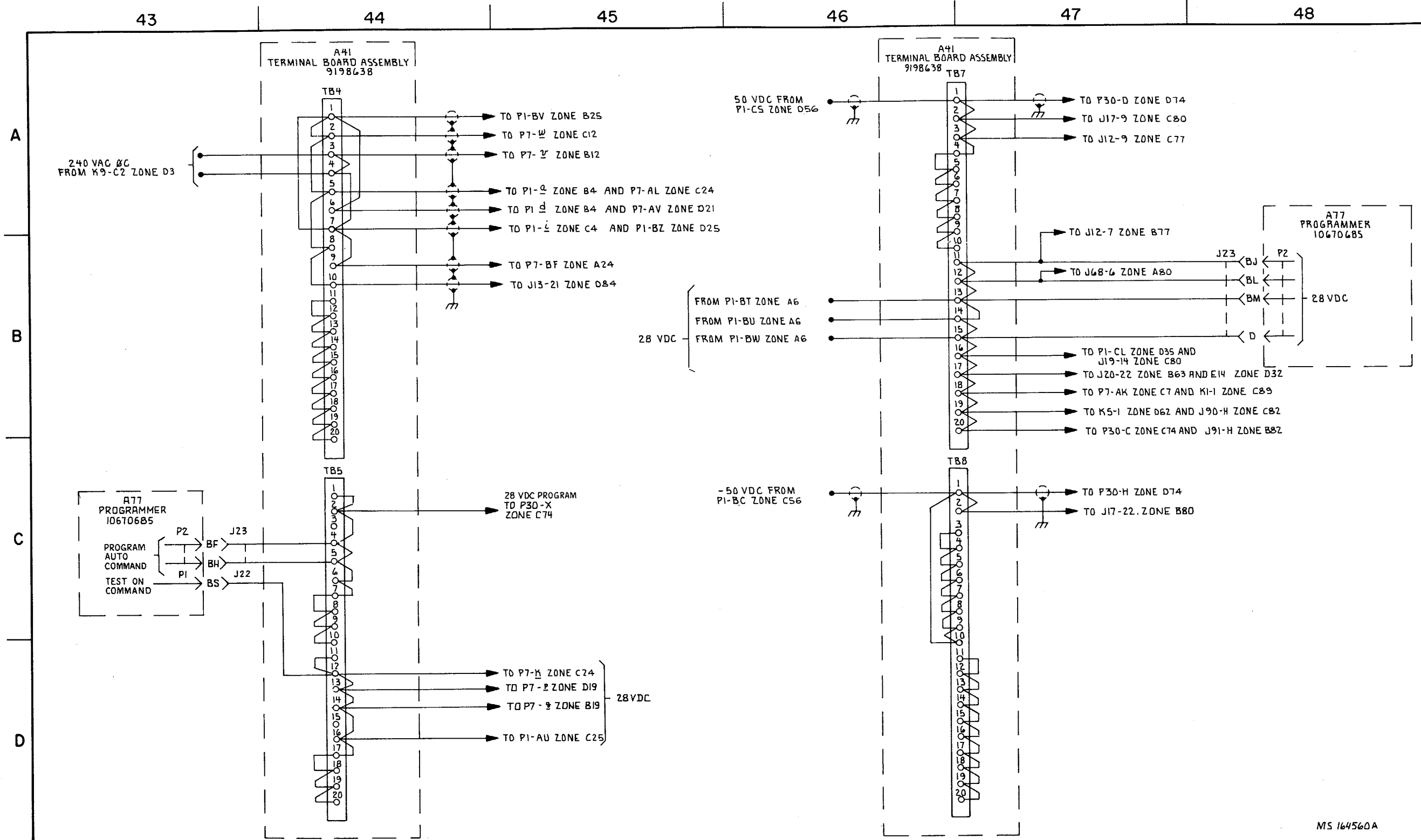

Figure 2-1. High-frequency console 10182561 (FG 3000)-interconnecting diagram (sheet 8 of 19).

MS 164560A

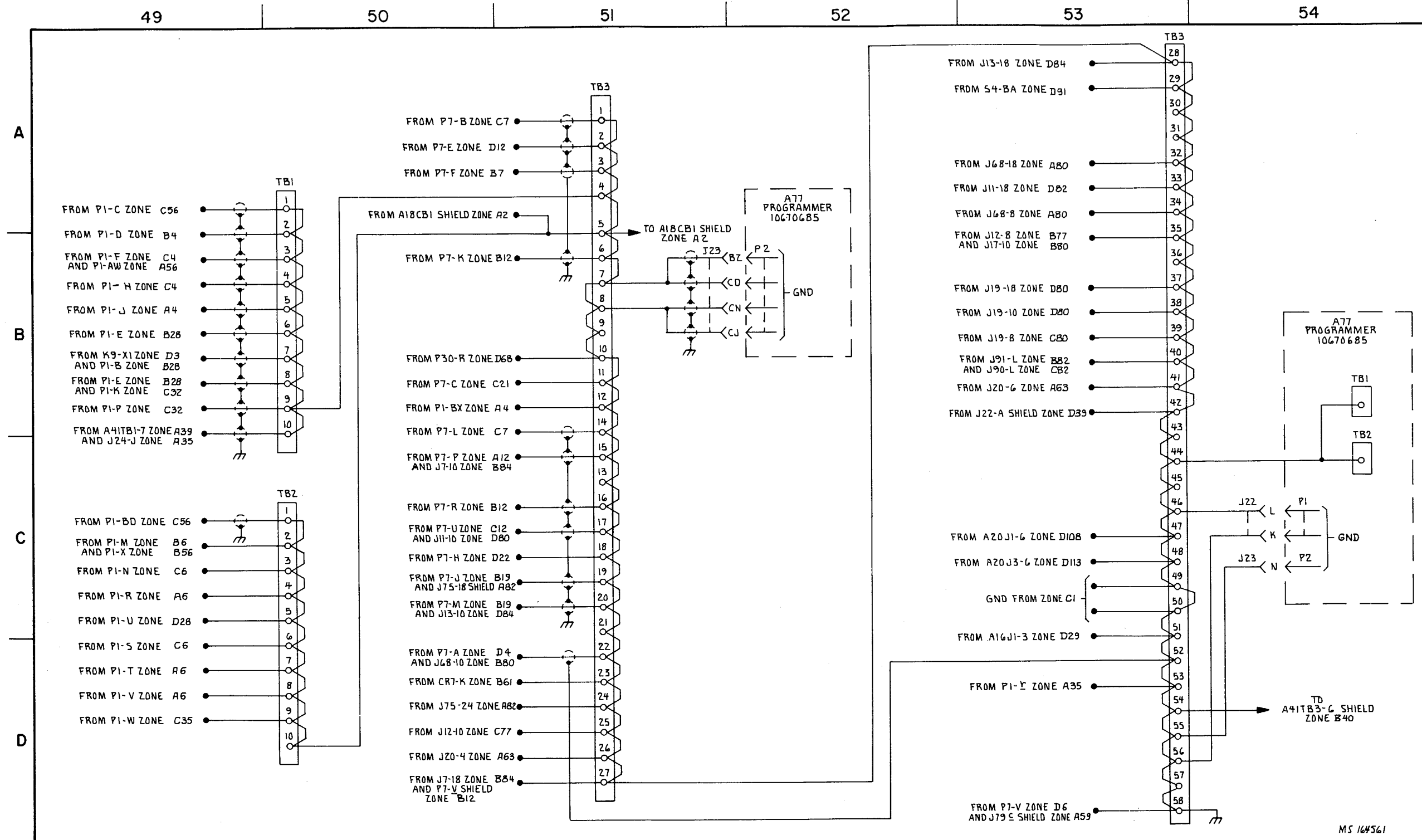
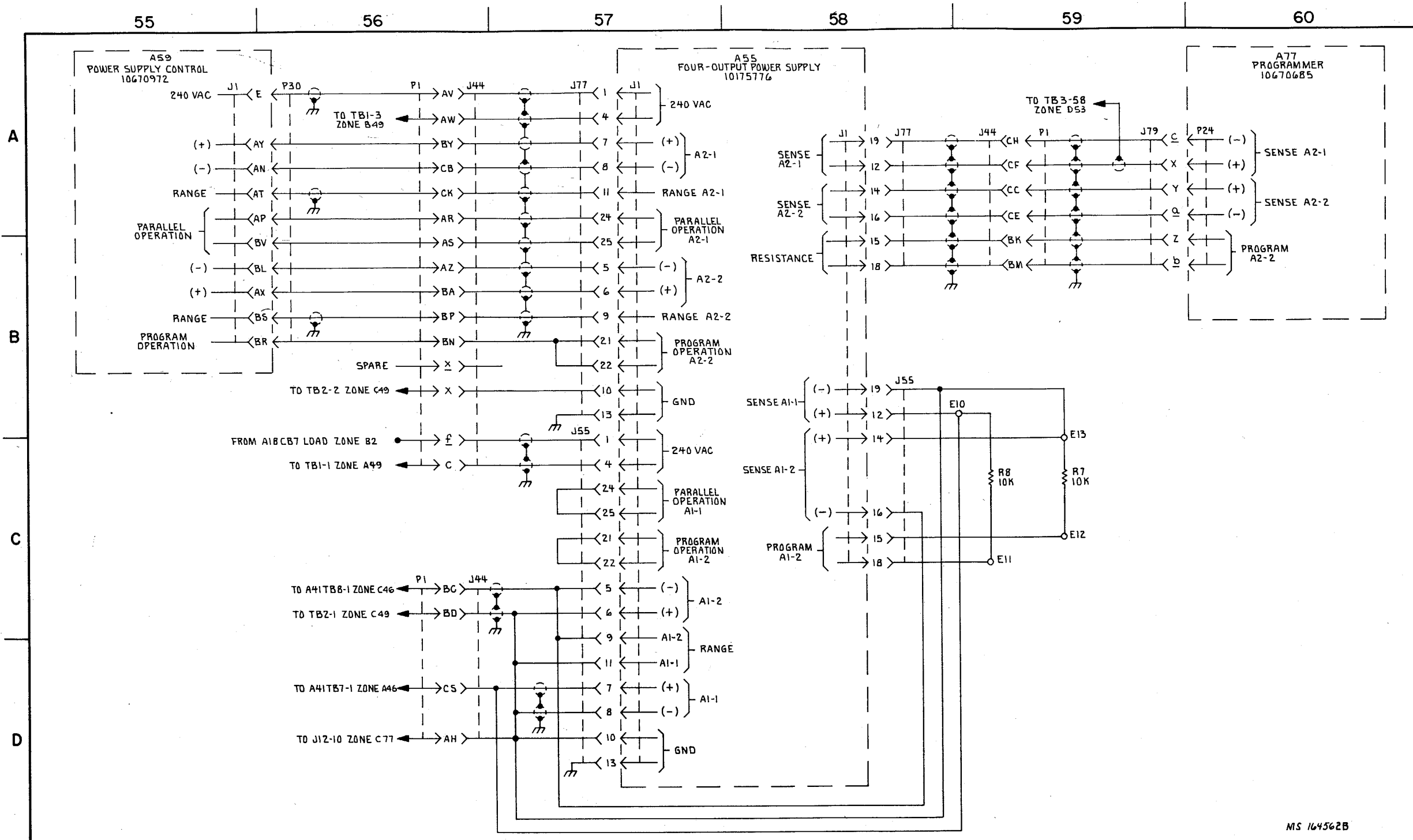
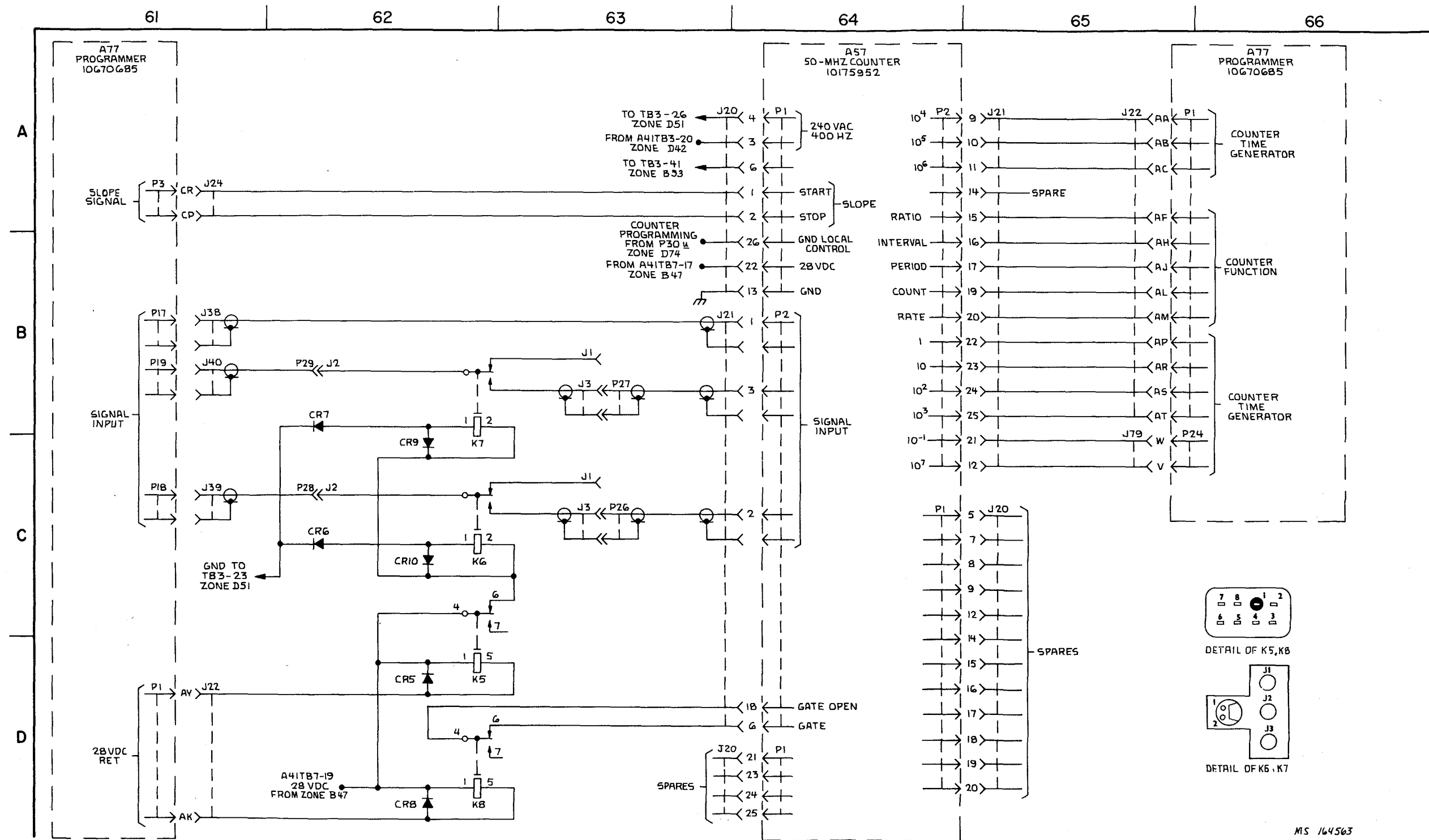

Figure 2-1. High-frequency console 10182561 (FG 3000)-interconnecting diagram (sheet 9 of 19).



MS 164562B

Figure 2-1. High-frequency console 10182561 (FG 3000)- interconnecting diagram (sheet 10 of 19).



MS 164563

Figure 2-1. High-frequency console 10182561 (FG 3000)-interconnecting diagram (sheet 11 of 19).

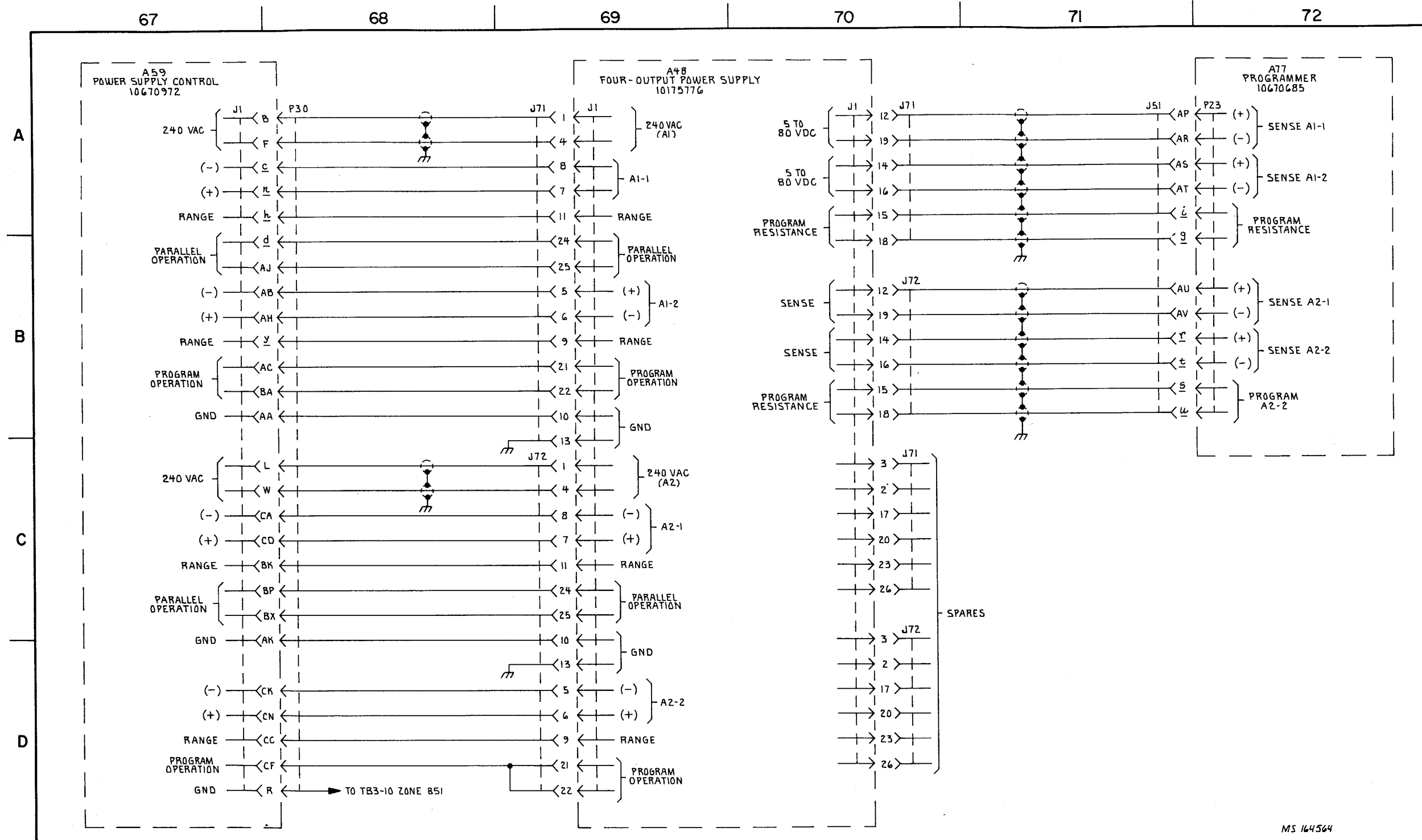

MS 164564

Figure 2-1. High-frequency console 10182561 (FG 3000)-interconnecting diagram (sheet 12 of 19).

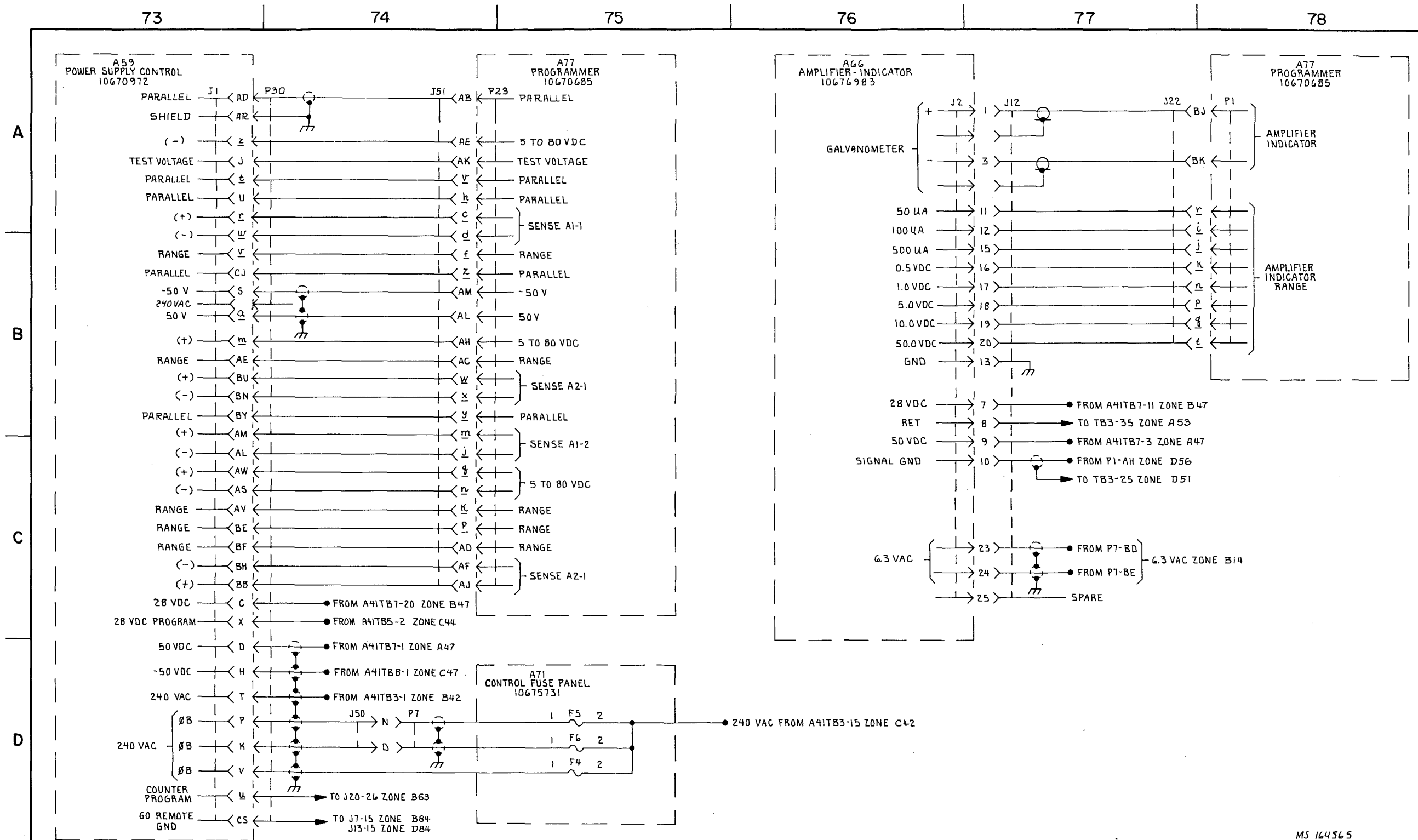

MS 164565

Figure 2-1. High-frequency console 10182561 (FG 3000)-interconnecting diagram (sheet 13 of 19).

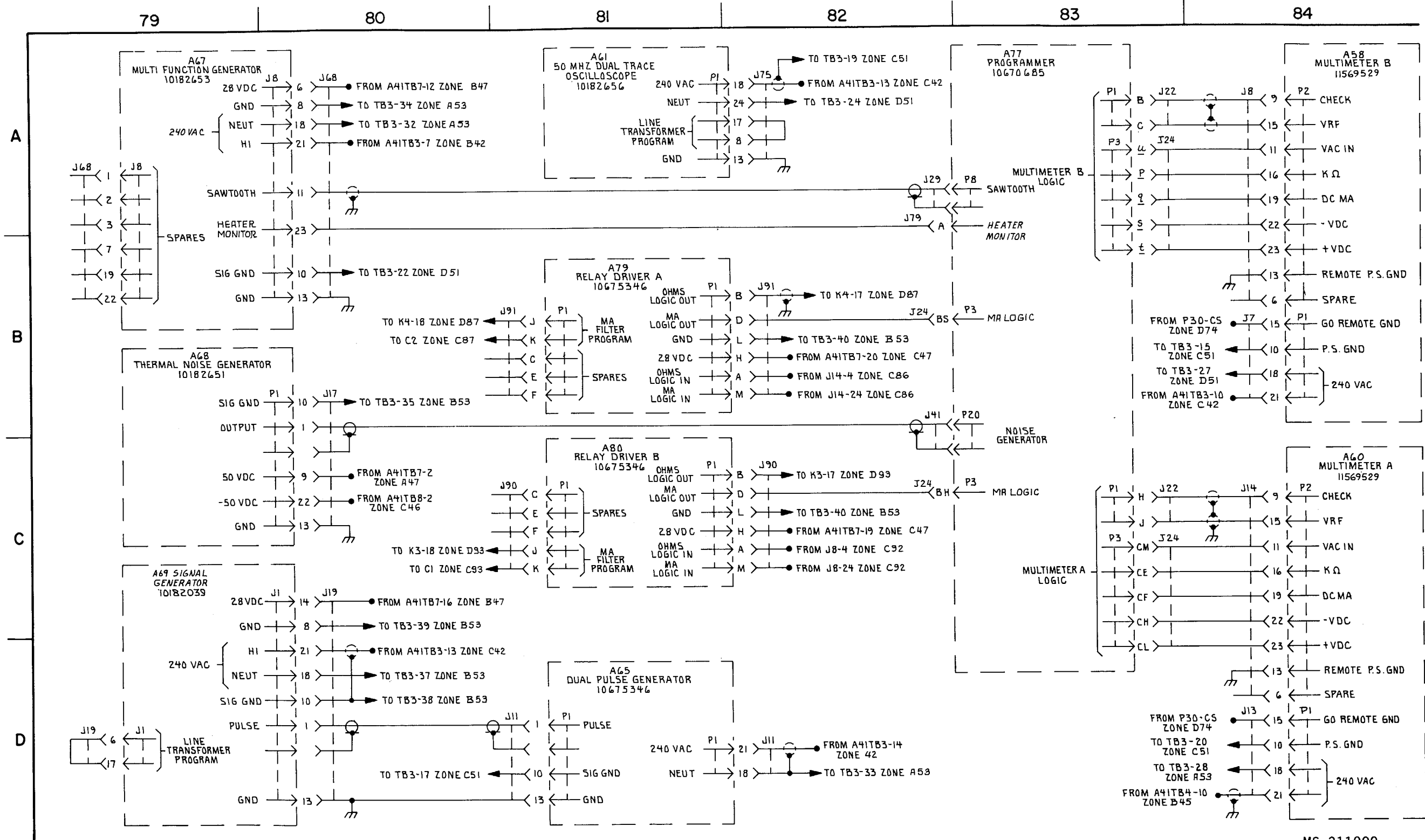
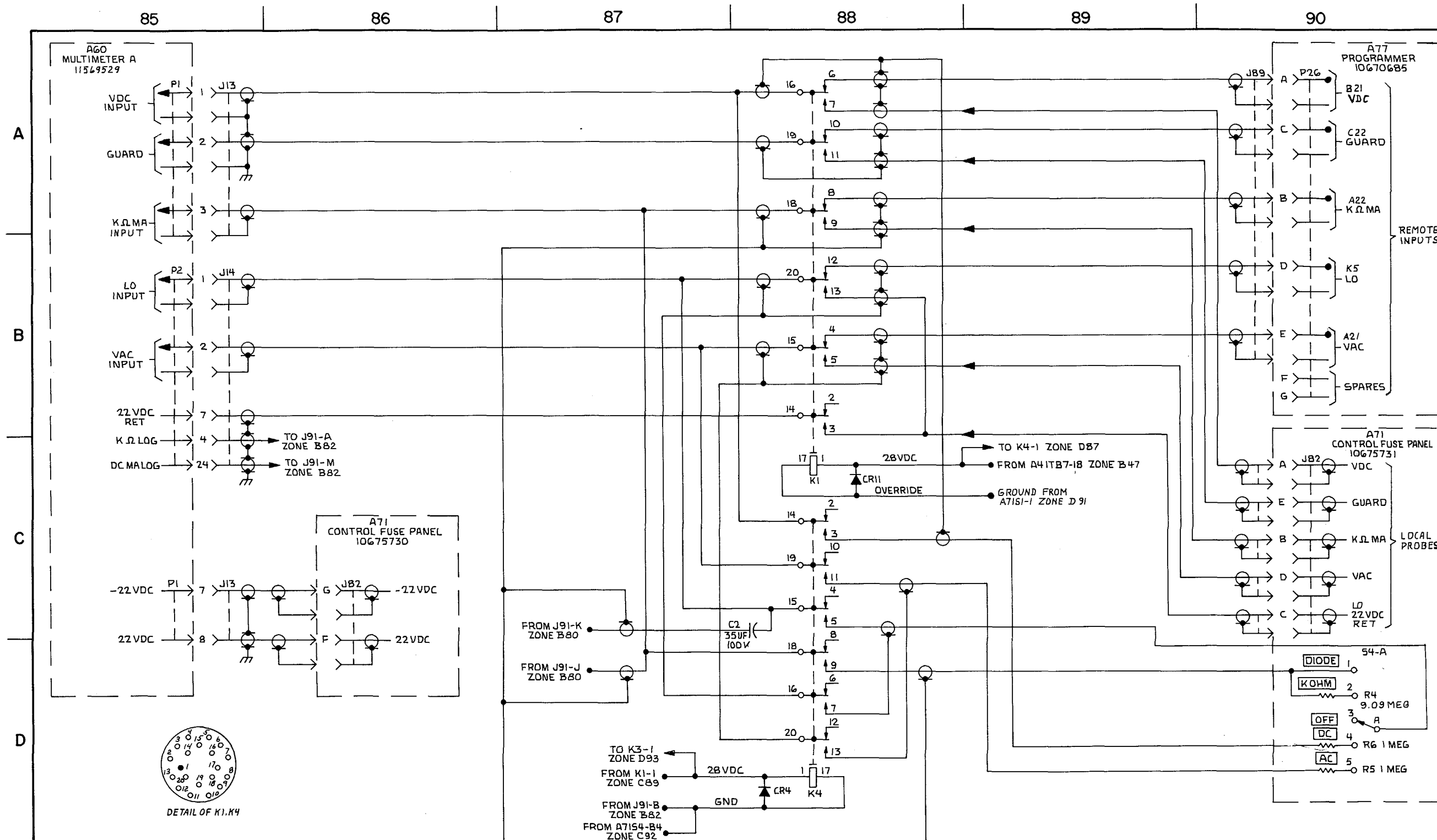

Figure 2-1. High-frequency console 10182561 (FG 3000)- interconnecting diagram (sheet 14 of 19).

MS 311900



MS 311901A

Figure 2-1. High-frequency console 10182561 (FG 3000)-interconnecting diagram (sheet 15 of 19).

2-29(2-30 blank)

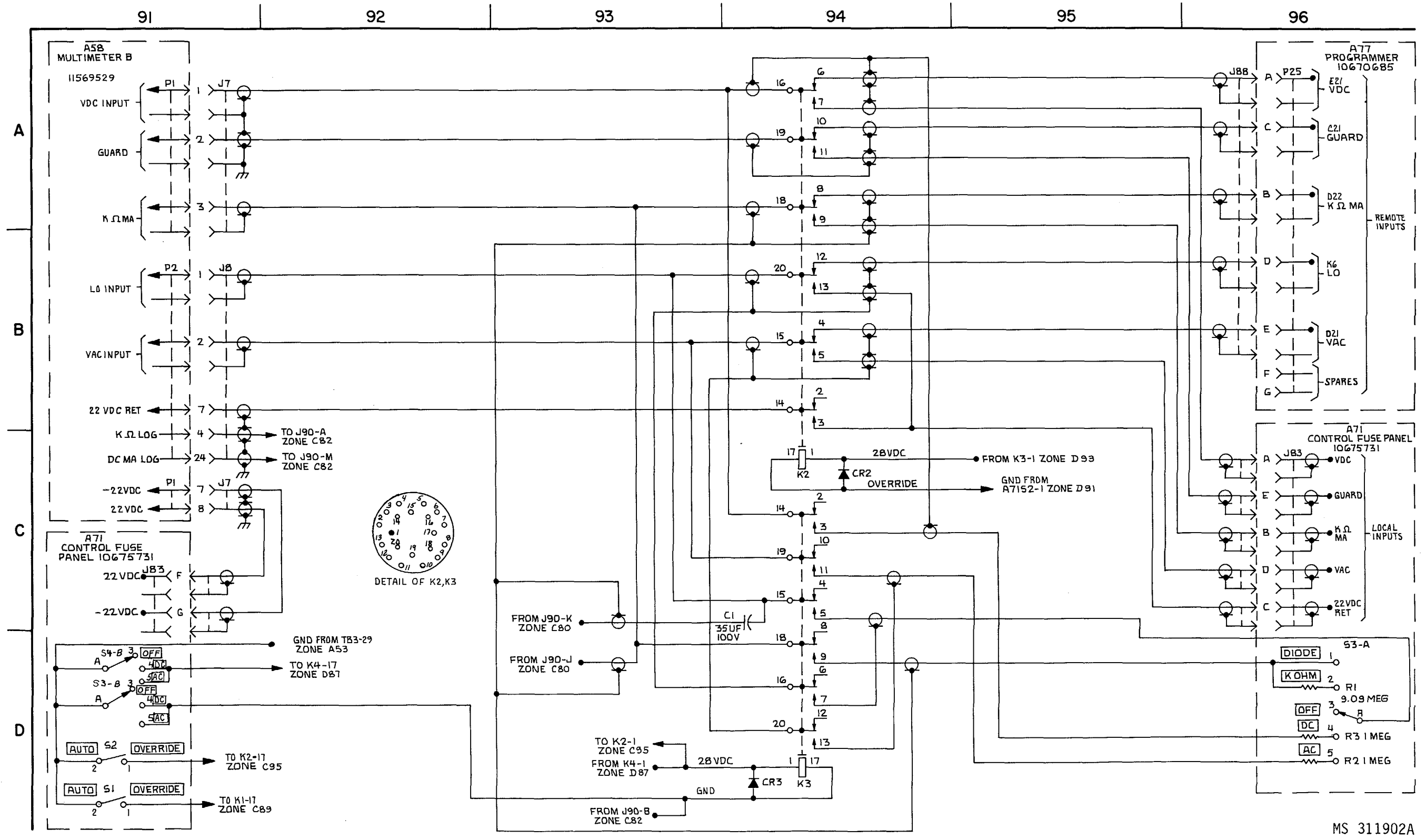

MS 311902A

Figure 2-1. High-frequency console 10182561 (FG 3000)-interconnecting diagram (sheet 16 of 19).

2-31(2-32 blank)

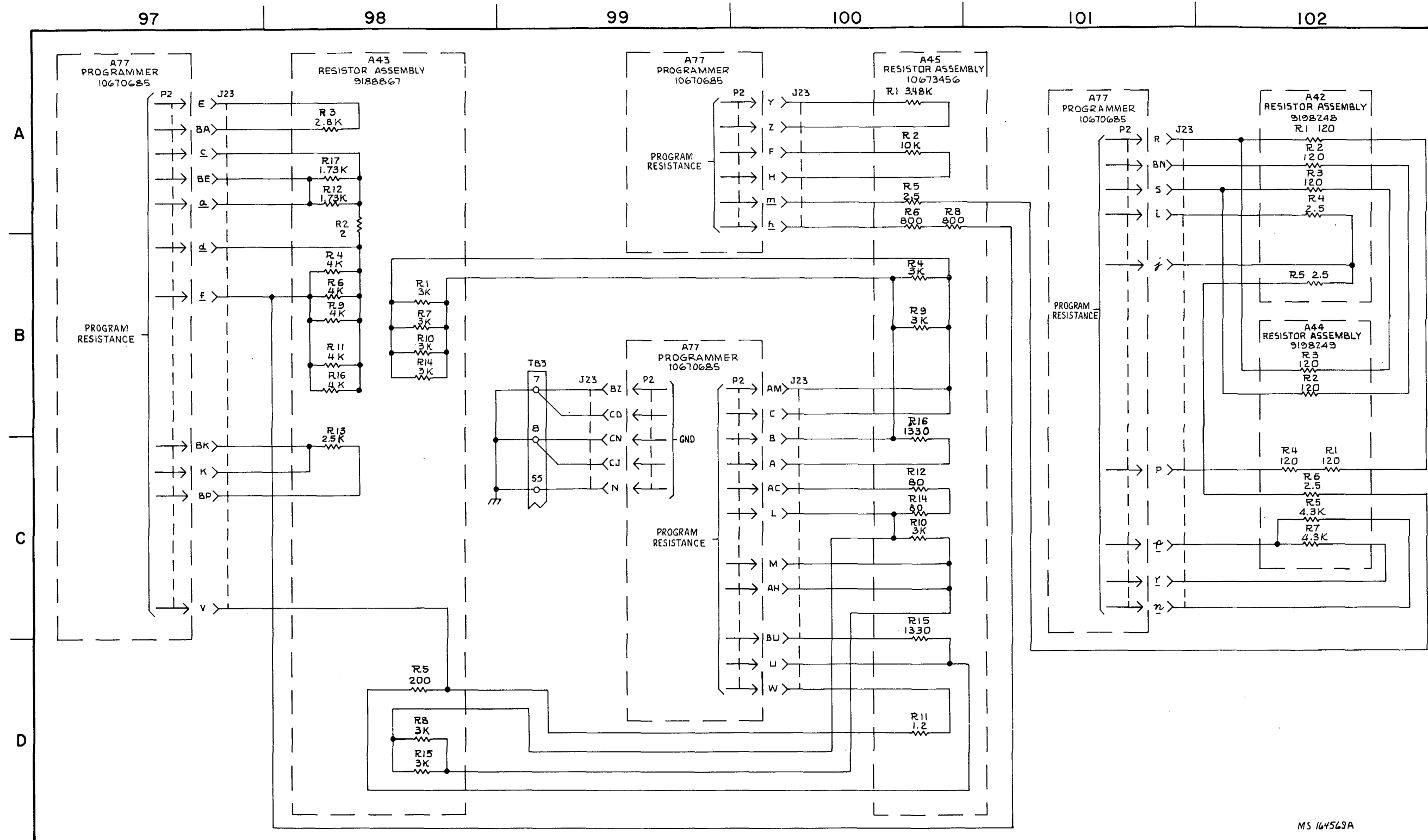

MS 164569A

Figure 2-1. High frequency console 10182561 (FG 3000)- interconnecting diagram (sheet 17 of 19).

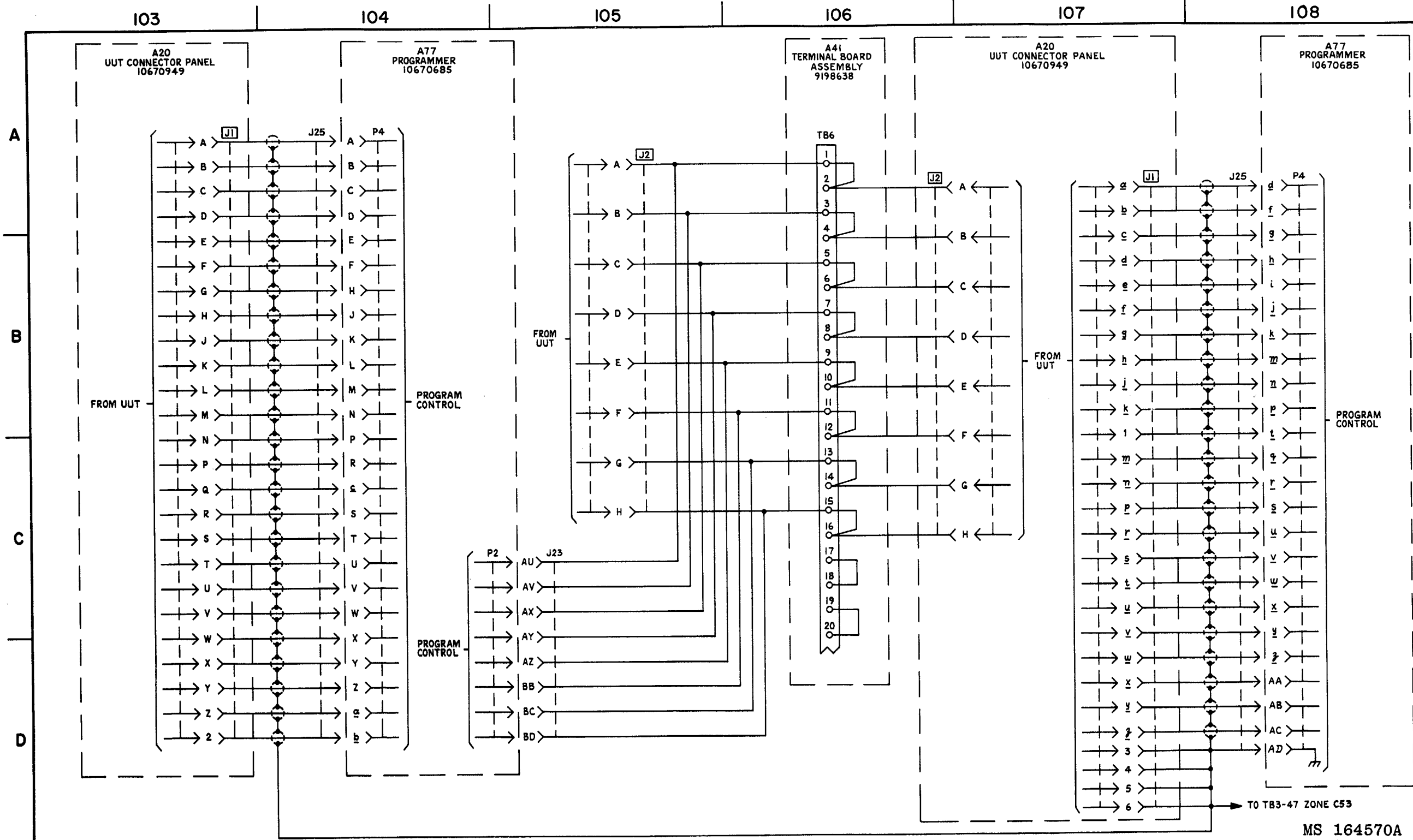
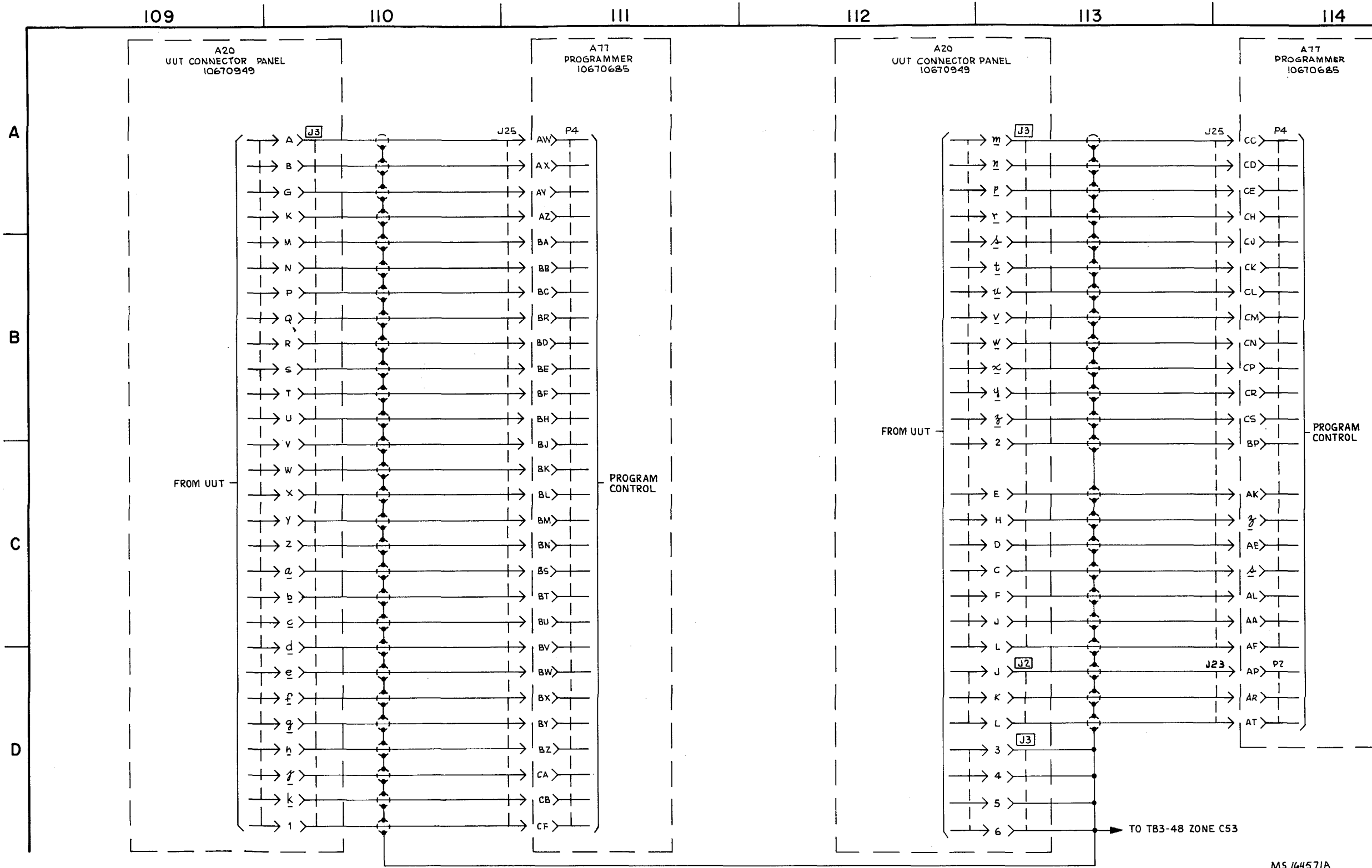

Figure 2-1. High frequency console 10182561 (FG 3000)- interconnecting diagram (sheet 18 of 19).



MS 164571A

Figure 2-1. High frequency console 10182561 (FG 3000)- interconnecting diagram (sheet 19 of 19).

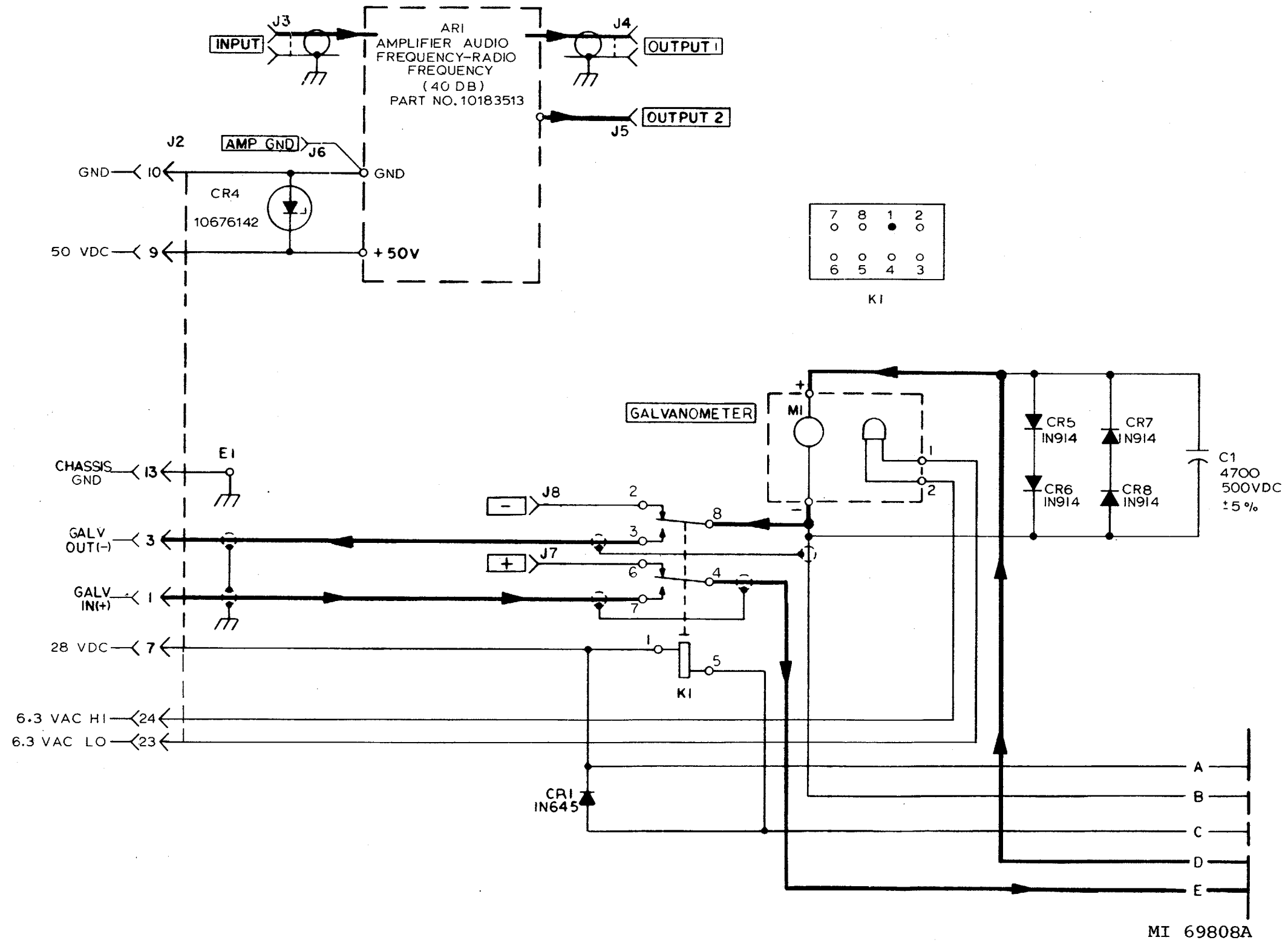

Figure 2-2. Amplifier-indicator 10676983 (A66) (FG 4600)-schematic (sheet 1 of 2).

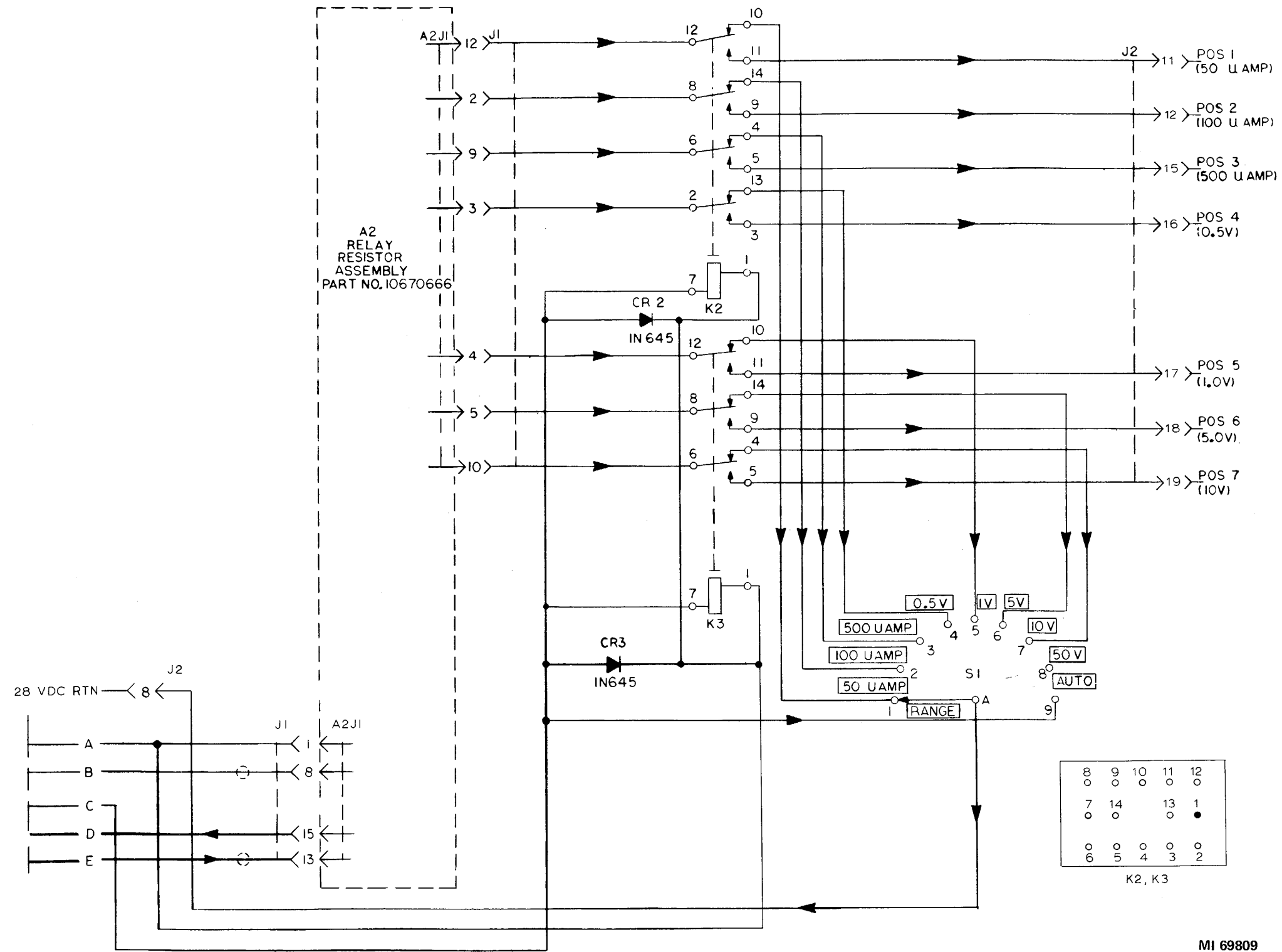

Figure 2-2. Amplifier-indicator 10676983 (A66) (FG 4600)-schematic (sheet 2 of 2).

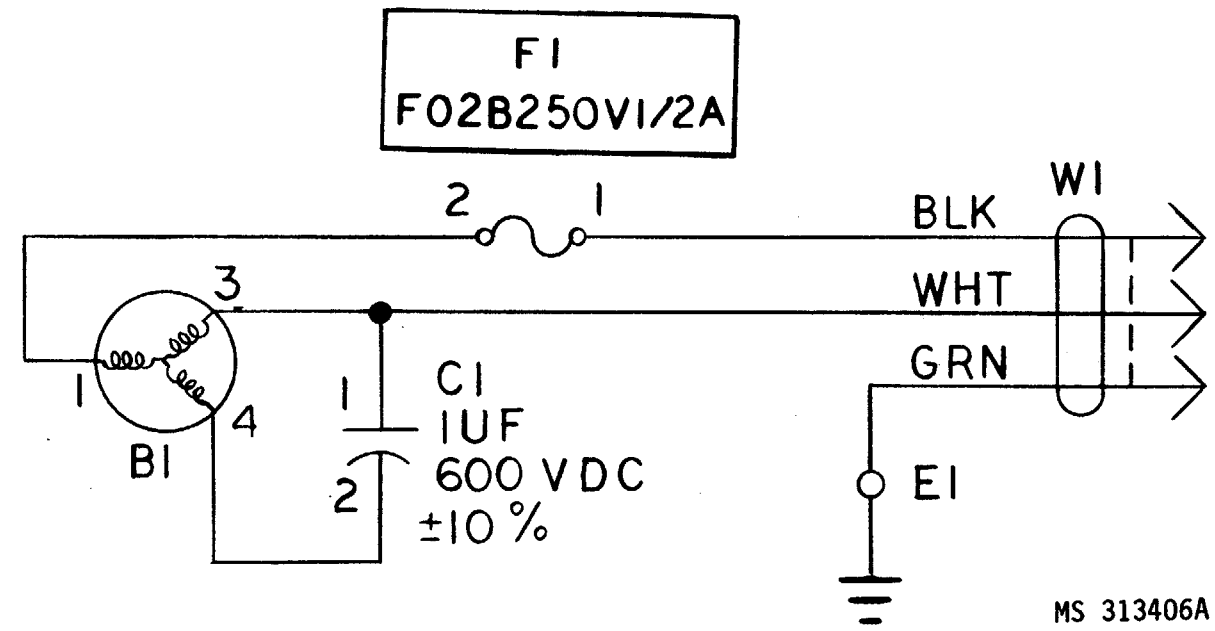

Figure 2-2.1. Electrical equipment drawer 11569991 A82-schematic.

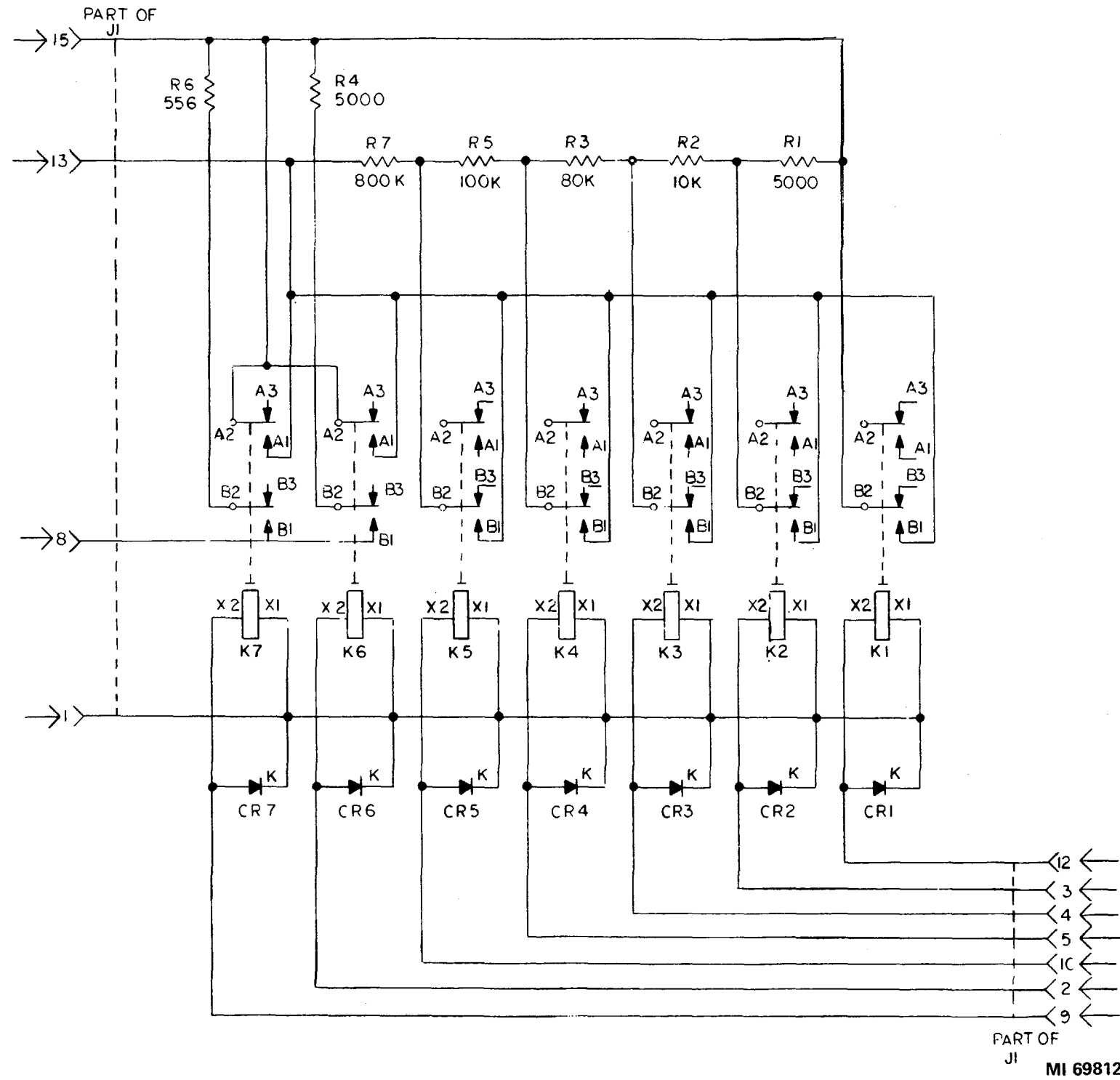
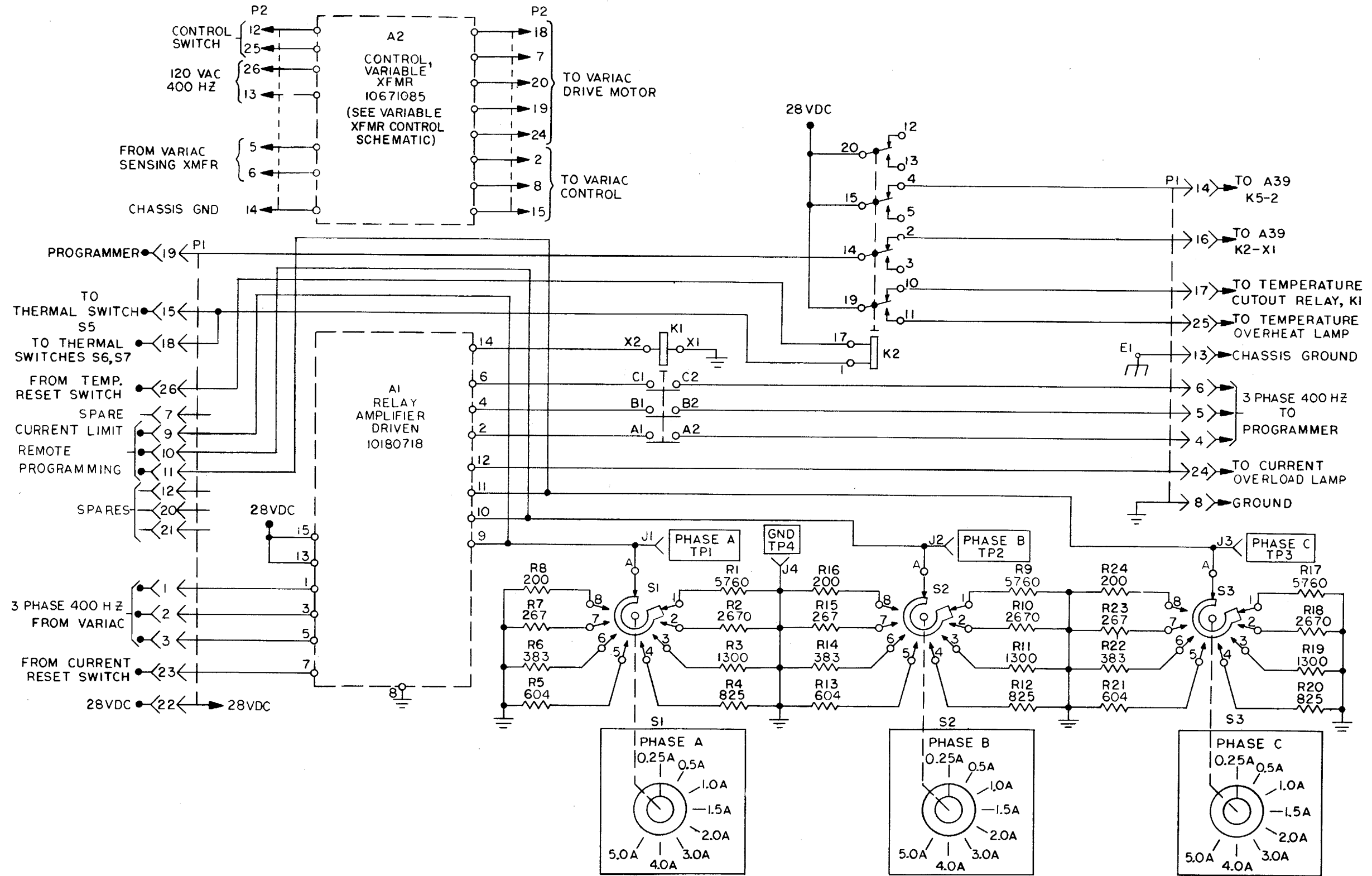

Figure 2-3. Relay assembly group (range program) 10670666 (A2) (FG 4620) -schematic.



MI 69813A

Figure 2-4. Console control 1076000 (A81) (FG 6200)-schematic.

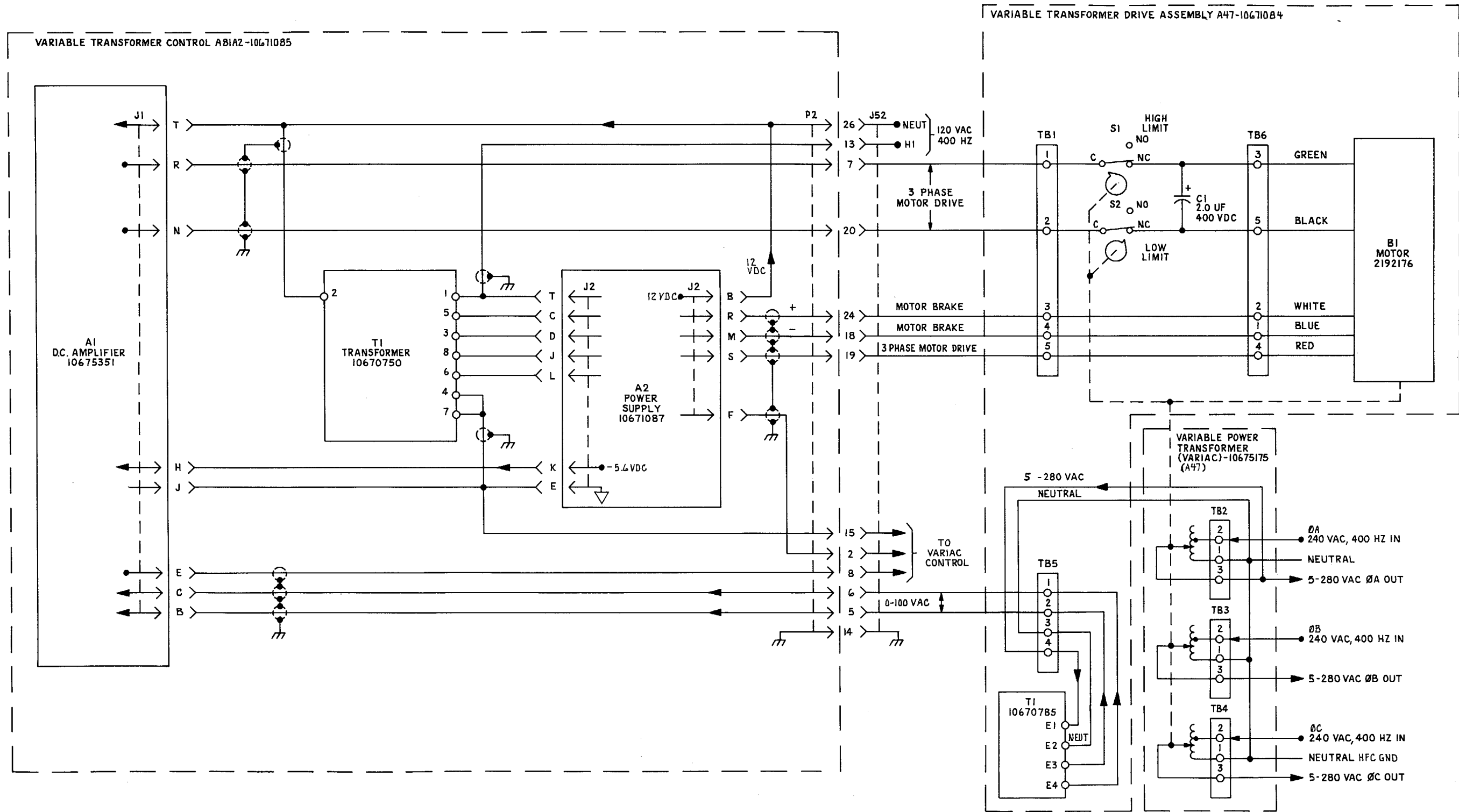
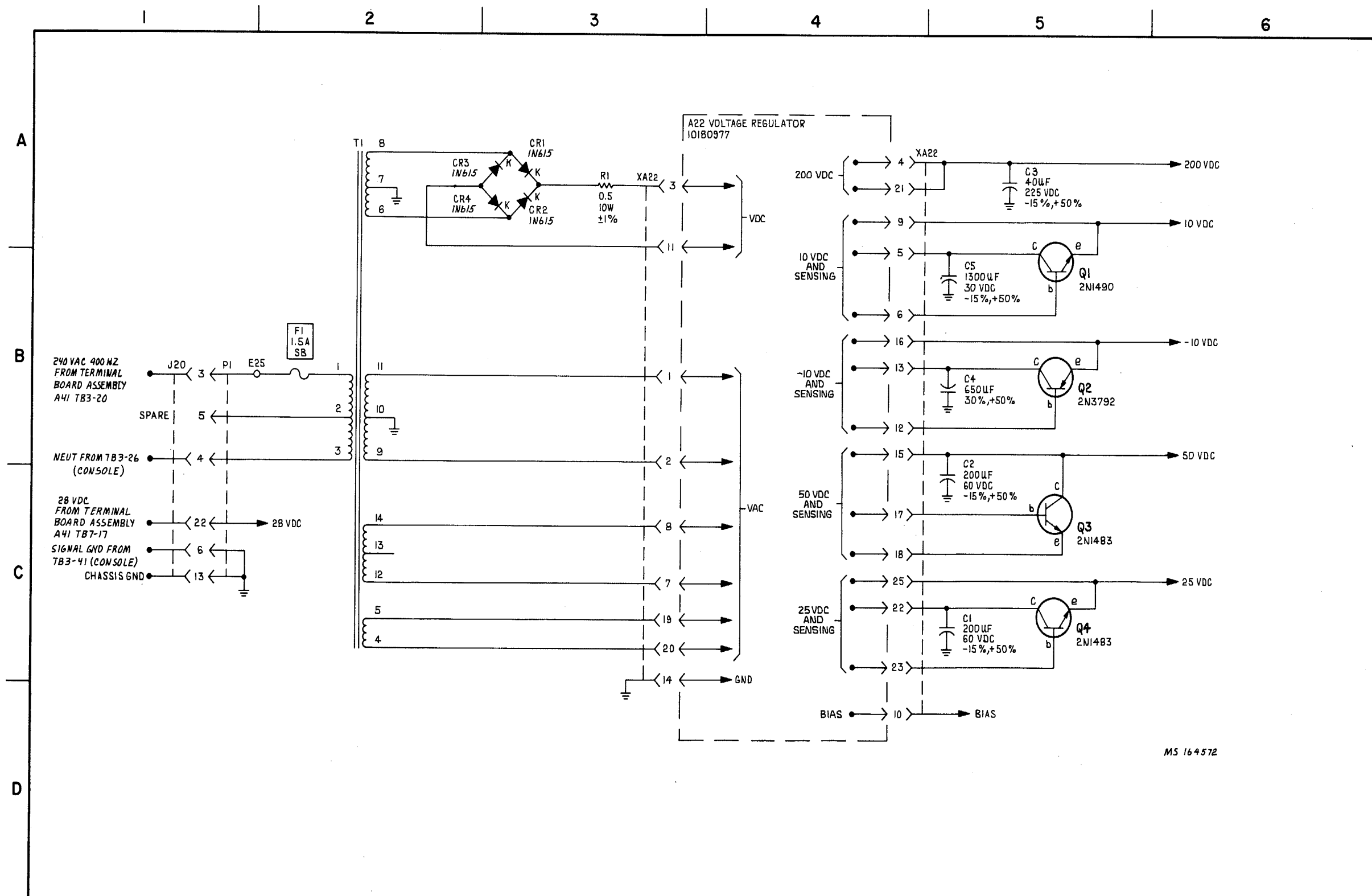
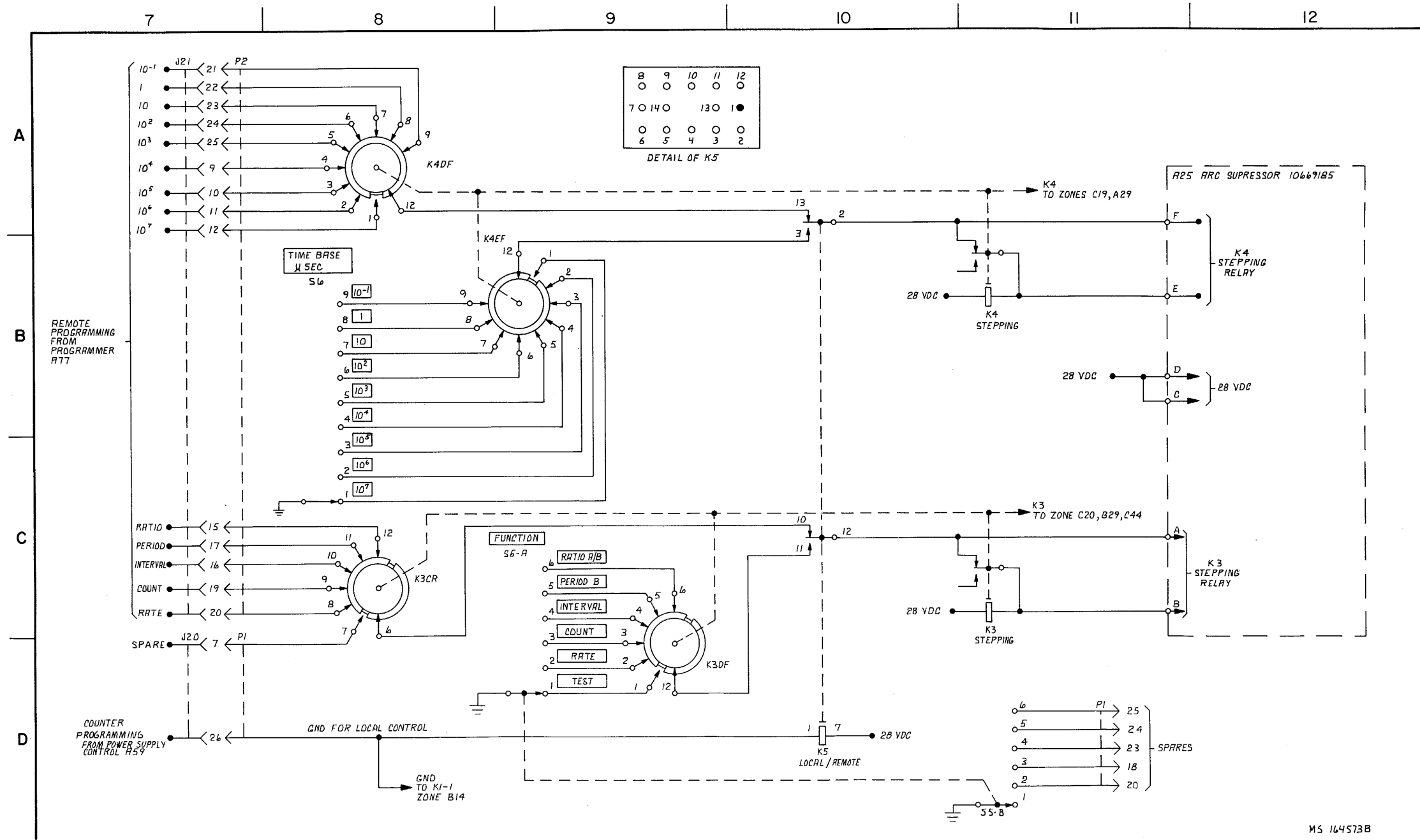

Figure 2-5. Variable transformer control 10671085 (A81A2), variable transfer drive 10671084 (A47), and variable power transformer 10675175 (A47)-schematic.



MS 164572

Figure 2-6. 50-MHz counter 10175952 (A57) (FG 4400)-schematic (sheet 1 of 8).



MS 164573B

Figure 2-6. 50-MHZ counter 10175952 (A57) (FG 4400)-schematic (sheet 2 of 8).
2-45

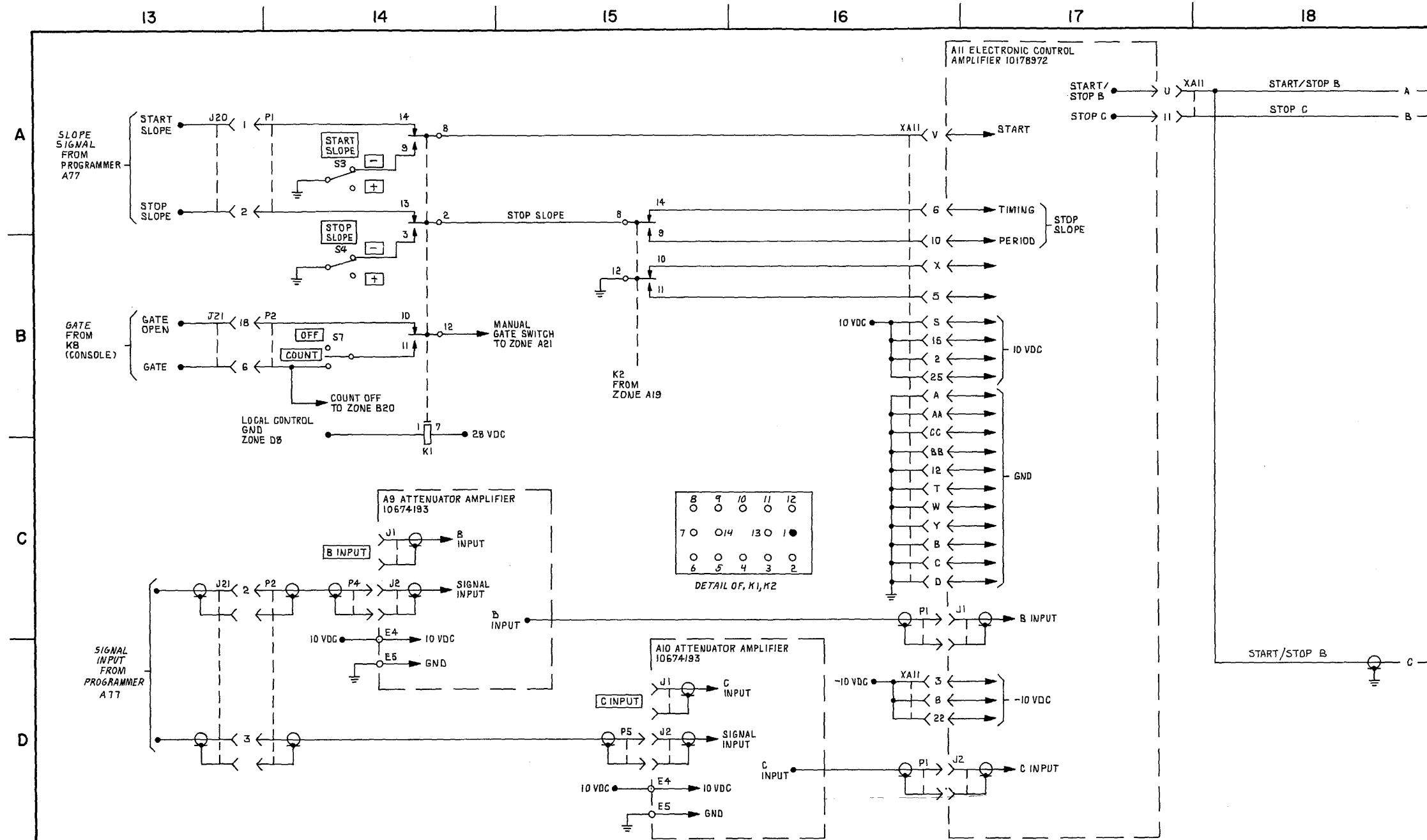
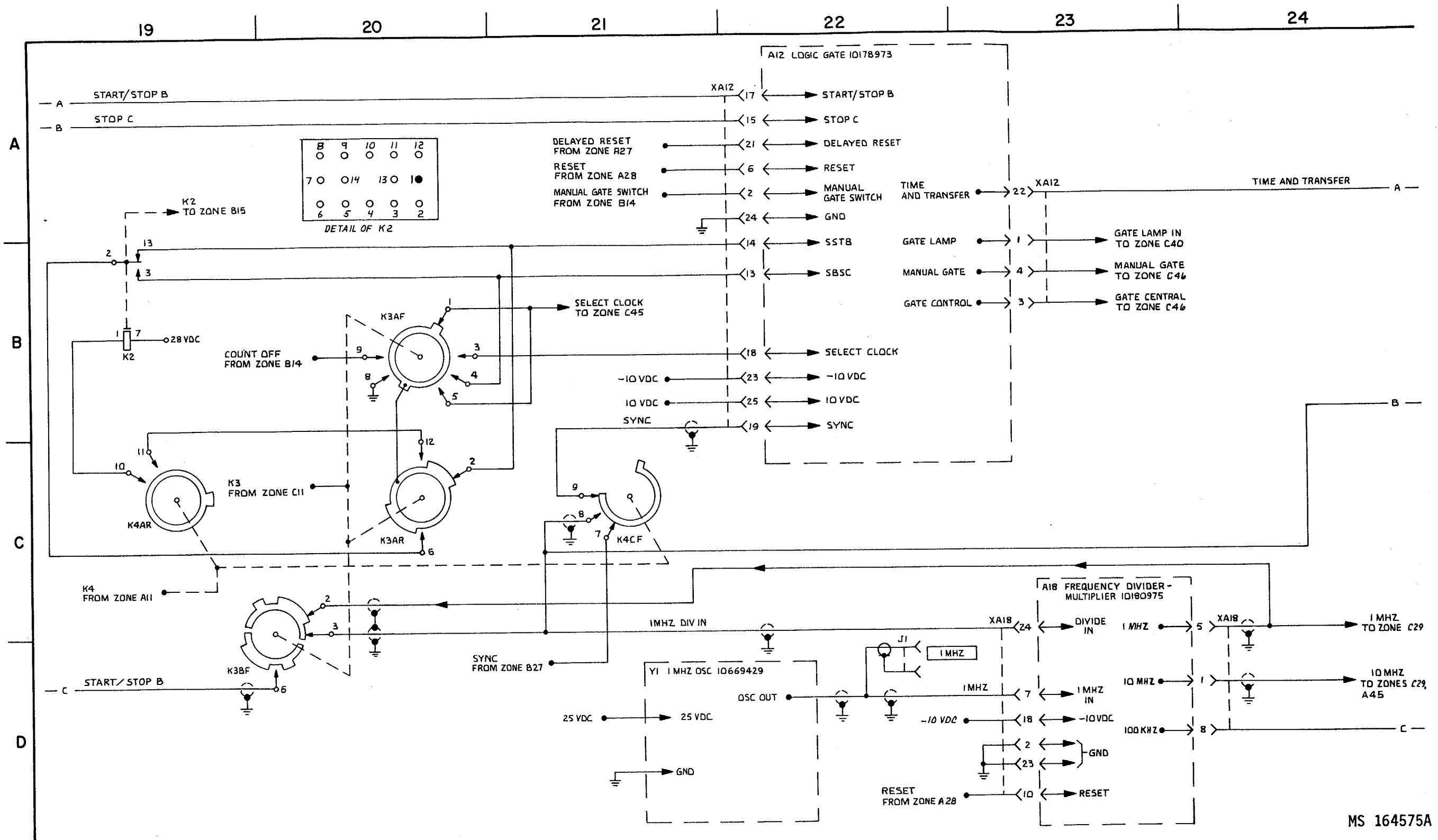

Figure 2-6. 50-MHZ counter 10175952 (A57) (FG 4400)-schematic (sheet 3 of 8).

MS 164574B

2-47(2-48 blank)



MS 164575A

Figure 2-6. 50-MHz counter 10175952 (A57) (FG 4400)-schematic (sheet 4 of 8).
2-49

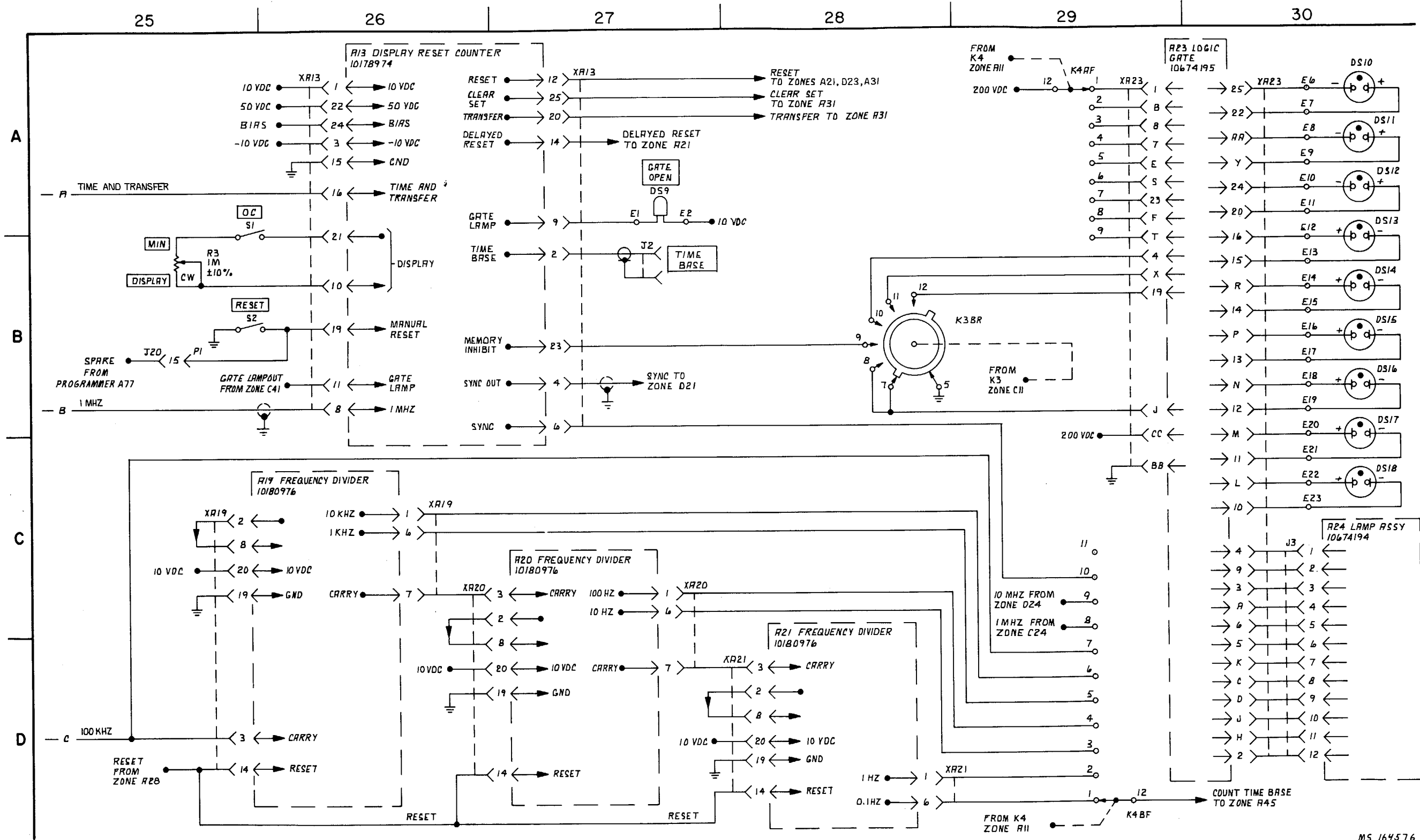
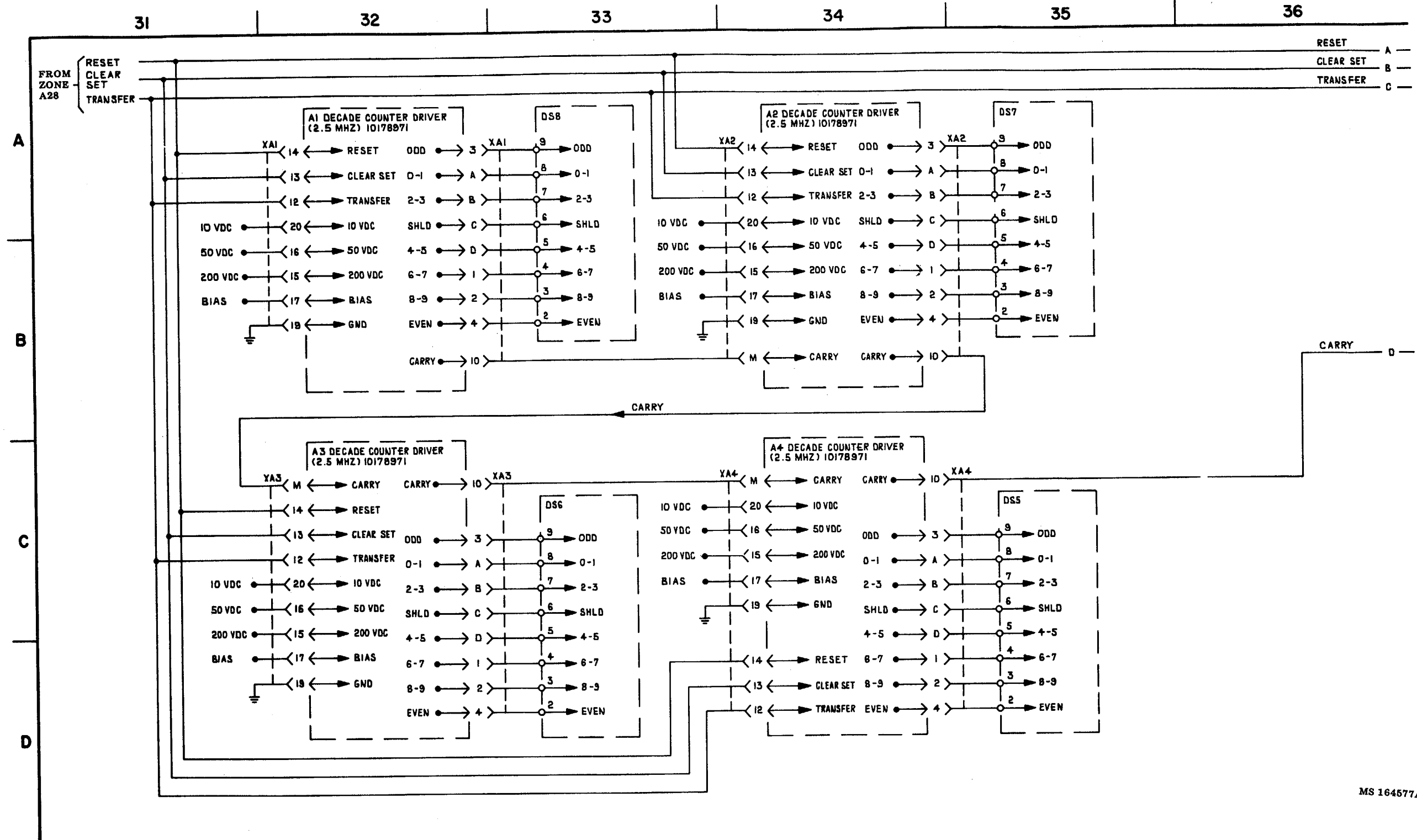
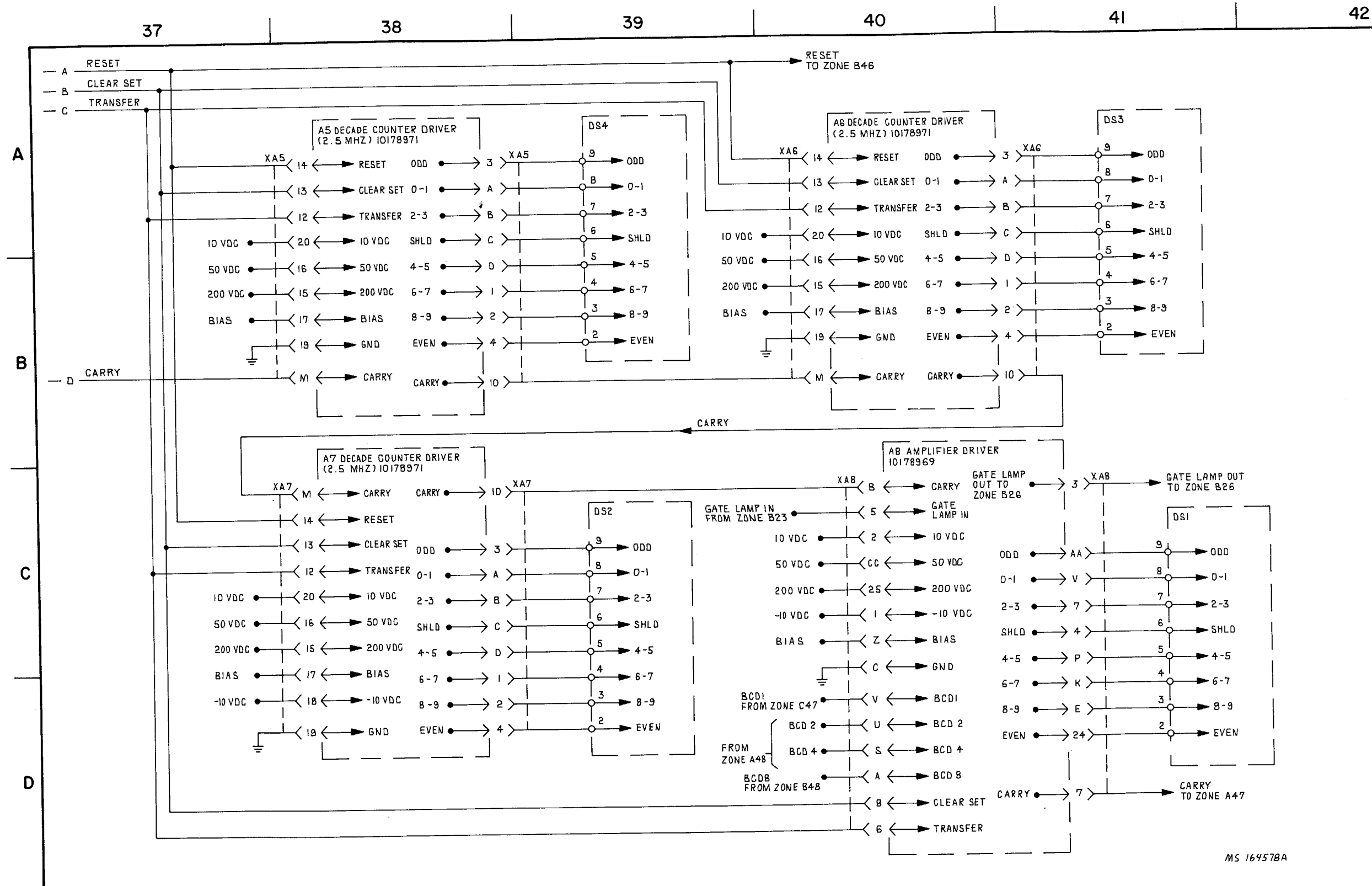

Figure 2-6. 50-MHz counter 10175952 (A57) (FG 4400)-schematic (sheet 5 of 8).



MS 164577A

Figure 2-6. 50-MHZ counter 10175952 (A57) (FG 4400)-schematic (sheet 6 of 8).



MS 164578A

Figure 2-6. 50-MHZ counter 10175952 (A57) (FG 4400)-schematic (sheet 7 of 8).
2-55

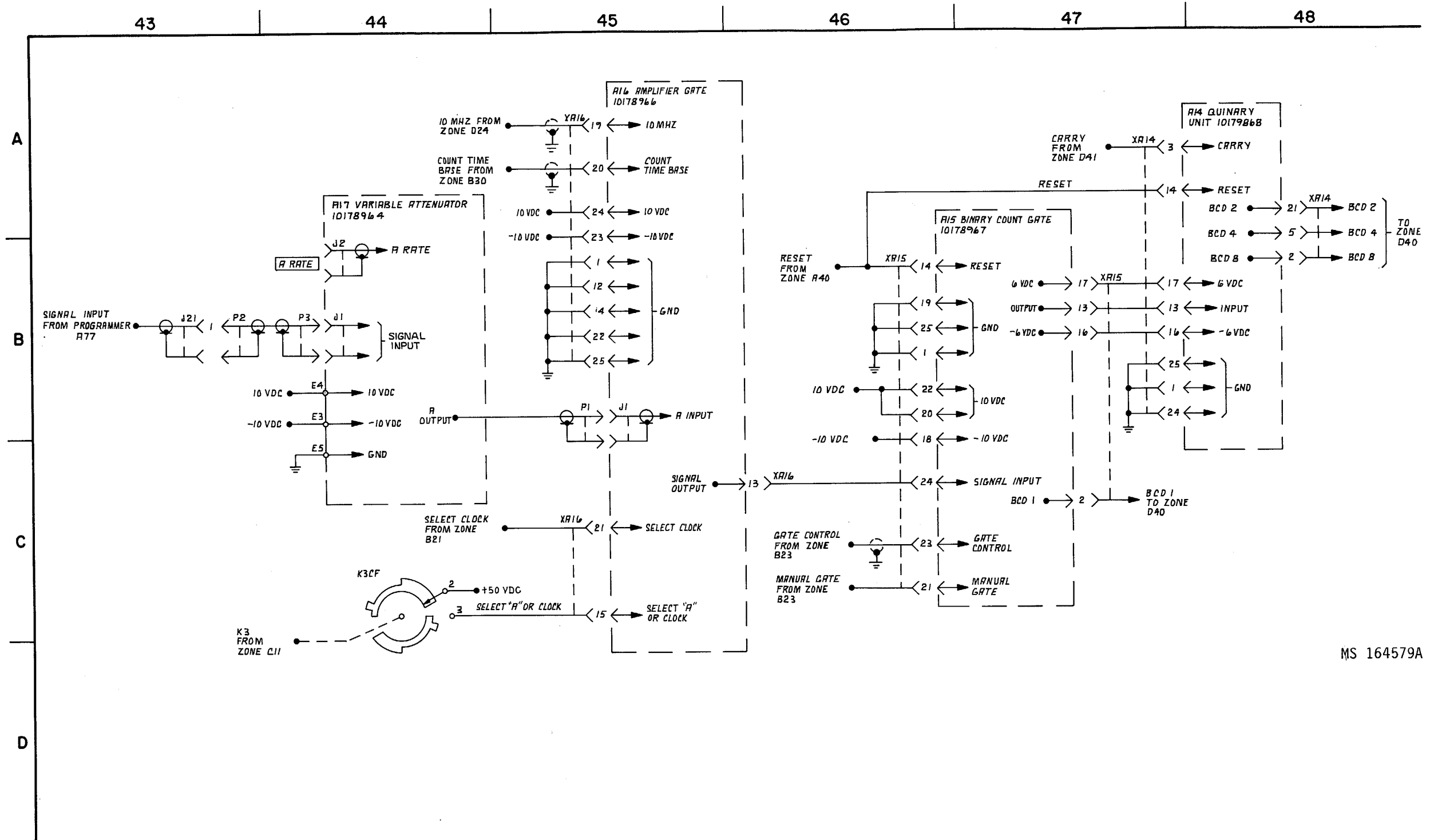

MS 164579A

Figure 2-6. 50-MHZ counter 10175952 (A57) (FG 4400)-schematic (sheet 8 of 8).

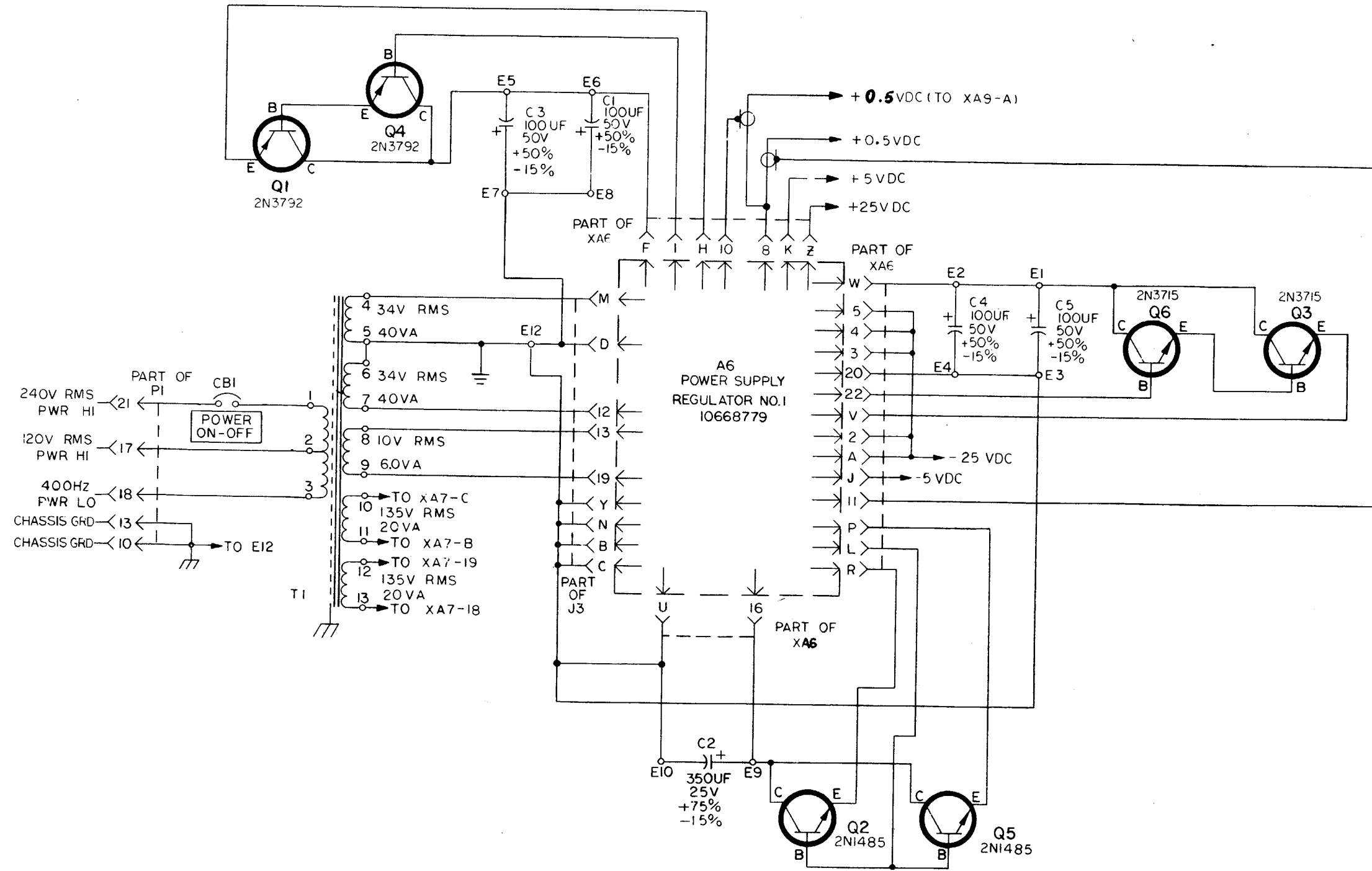

MI 69819

Figure 2-7. Dual-pulse generator 10182657 (A65 (FG 5200) - (sheet 1 of 3)

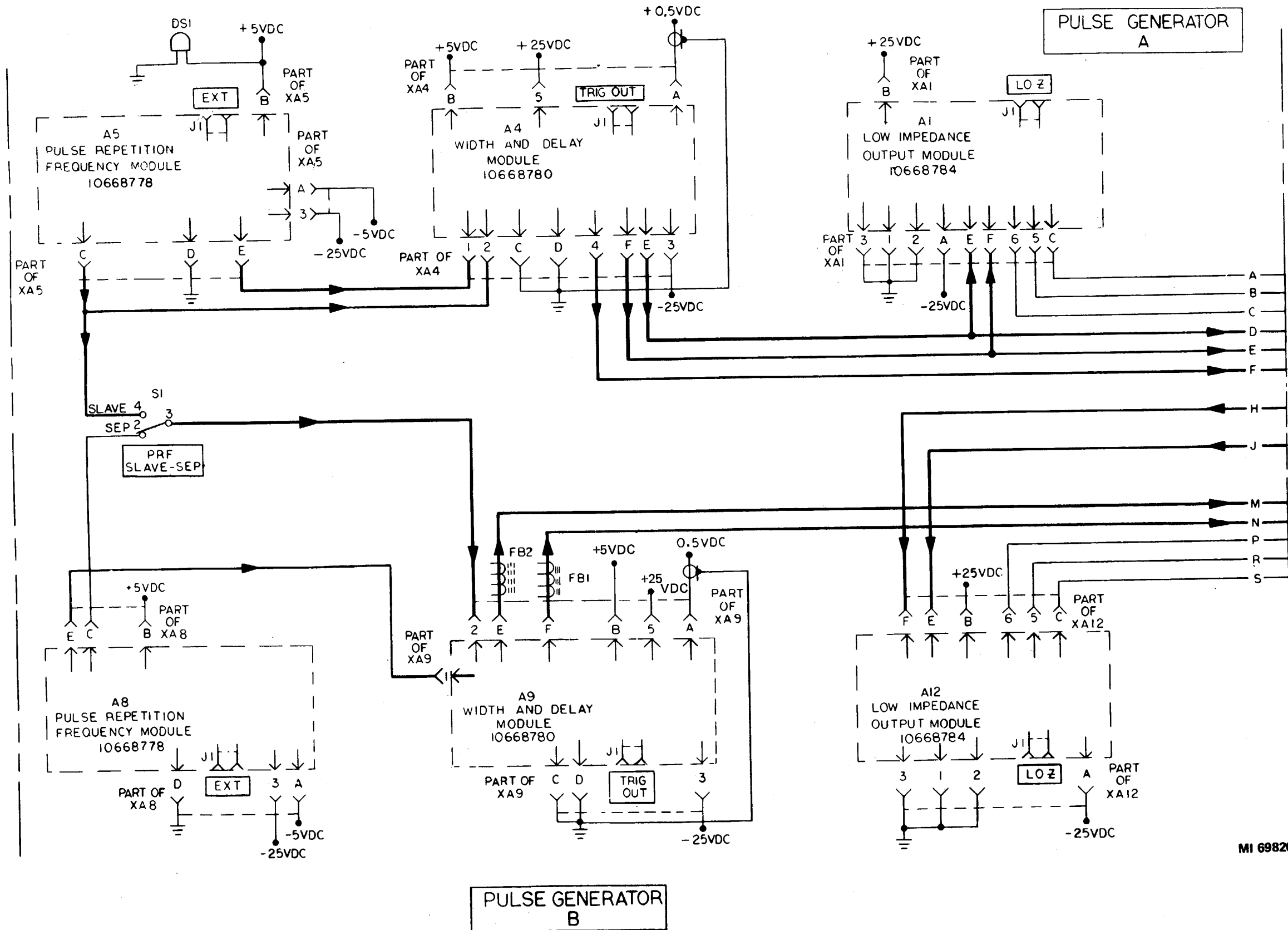

Figure 2-7. Dual-pulse generator 10182657 (A65) (FG5200) - schematic (sheet 2 of 3)
2-59 (2-60 blank)

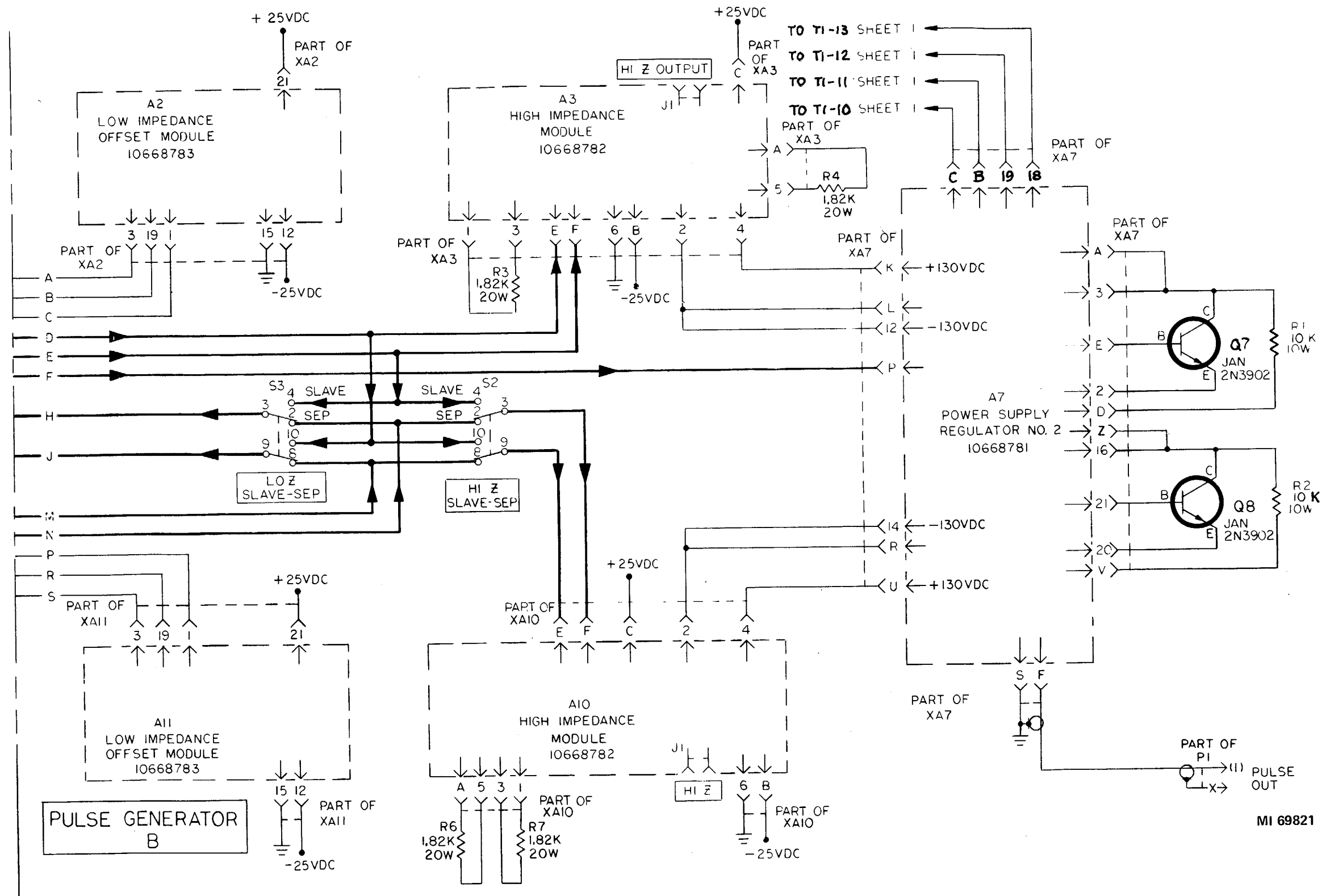

Figure 2-7. Dual-pulse generator 10182657 (A65) (FG 5200) - schematic (sheet 3 of 3)

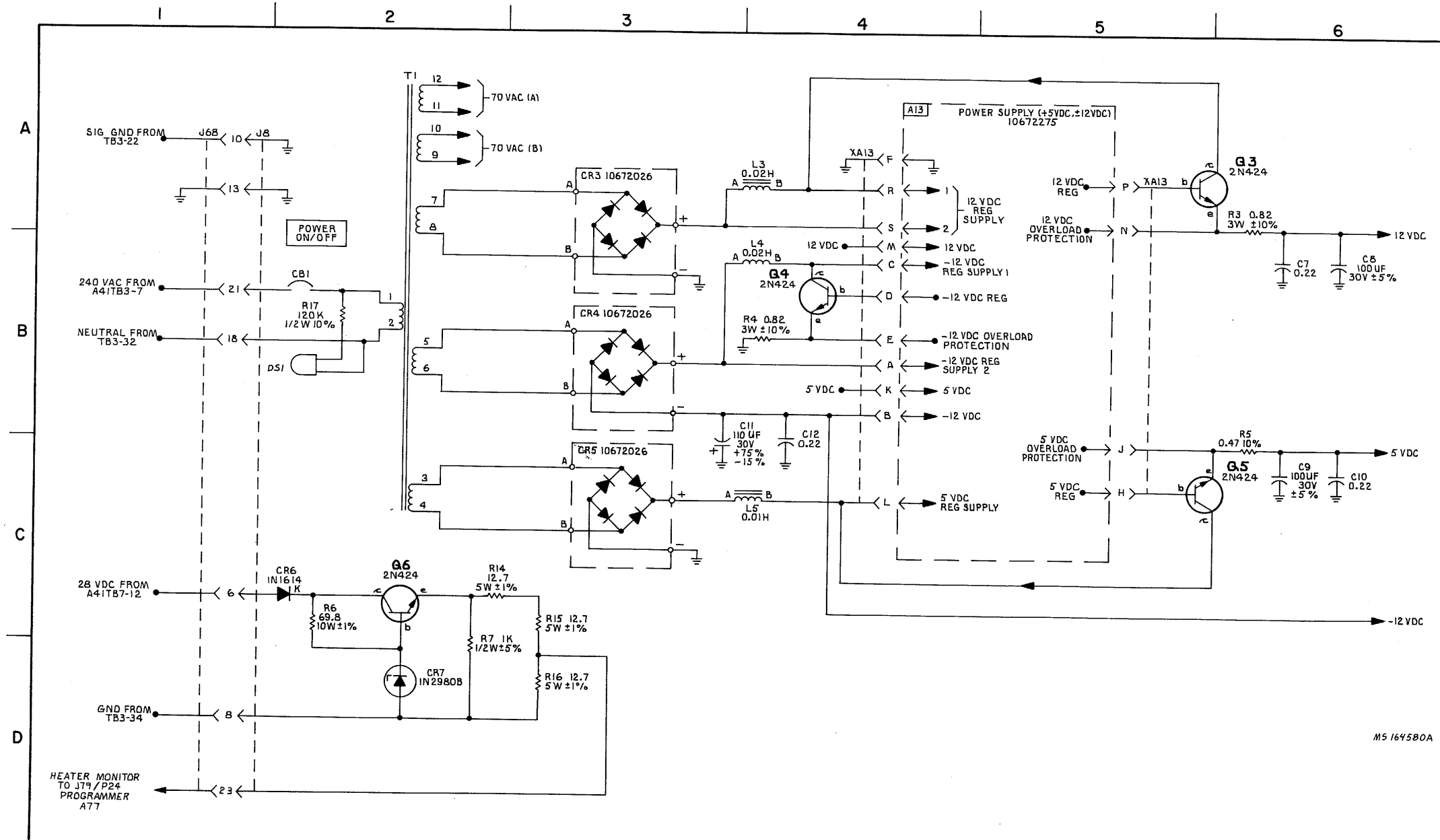
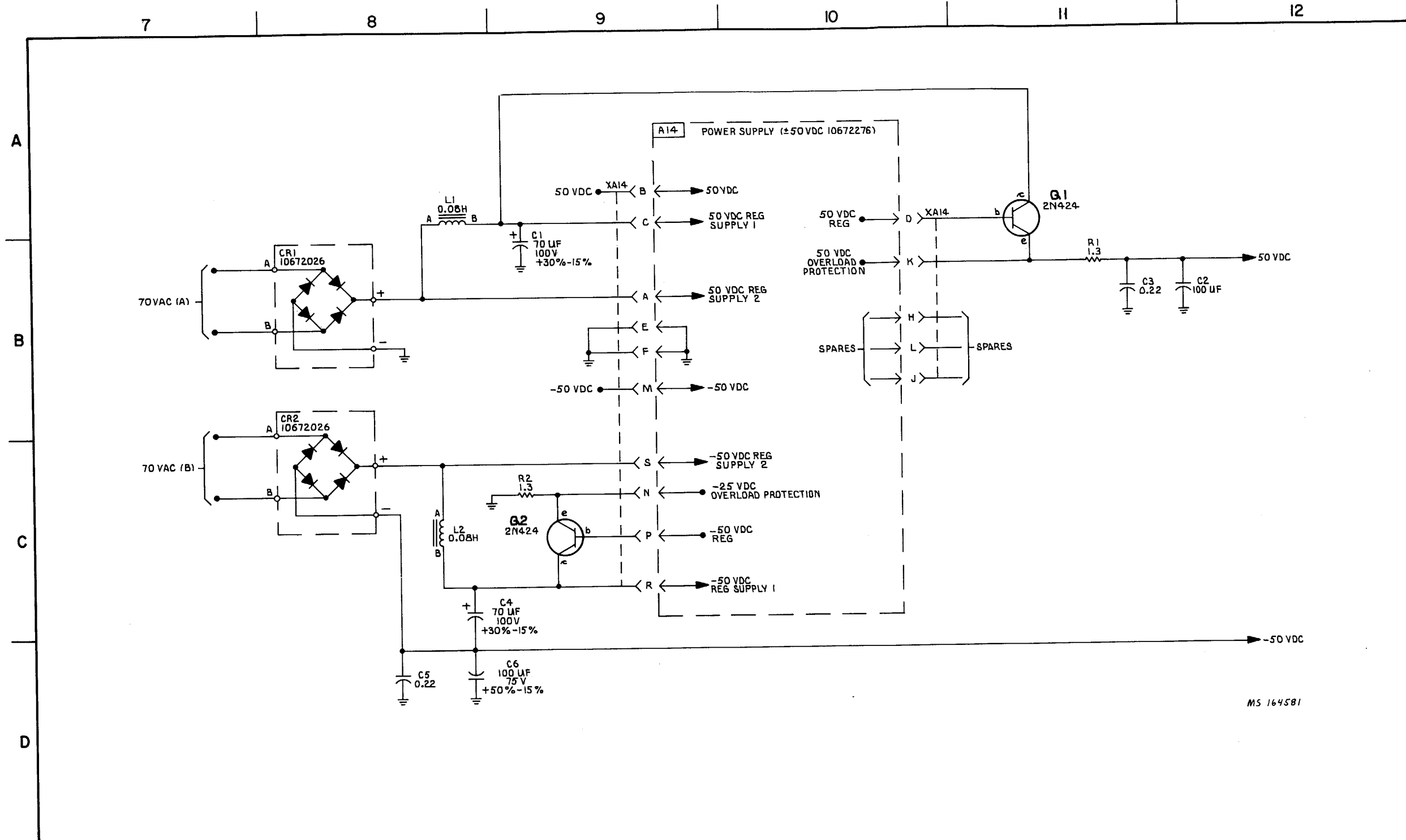
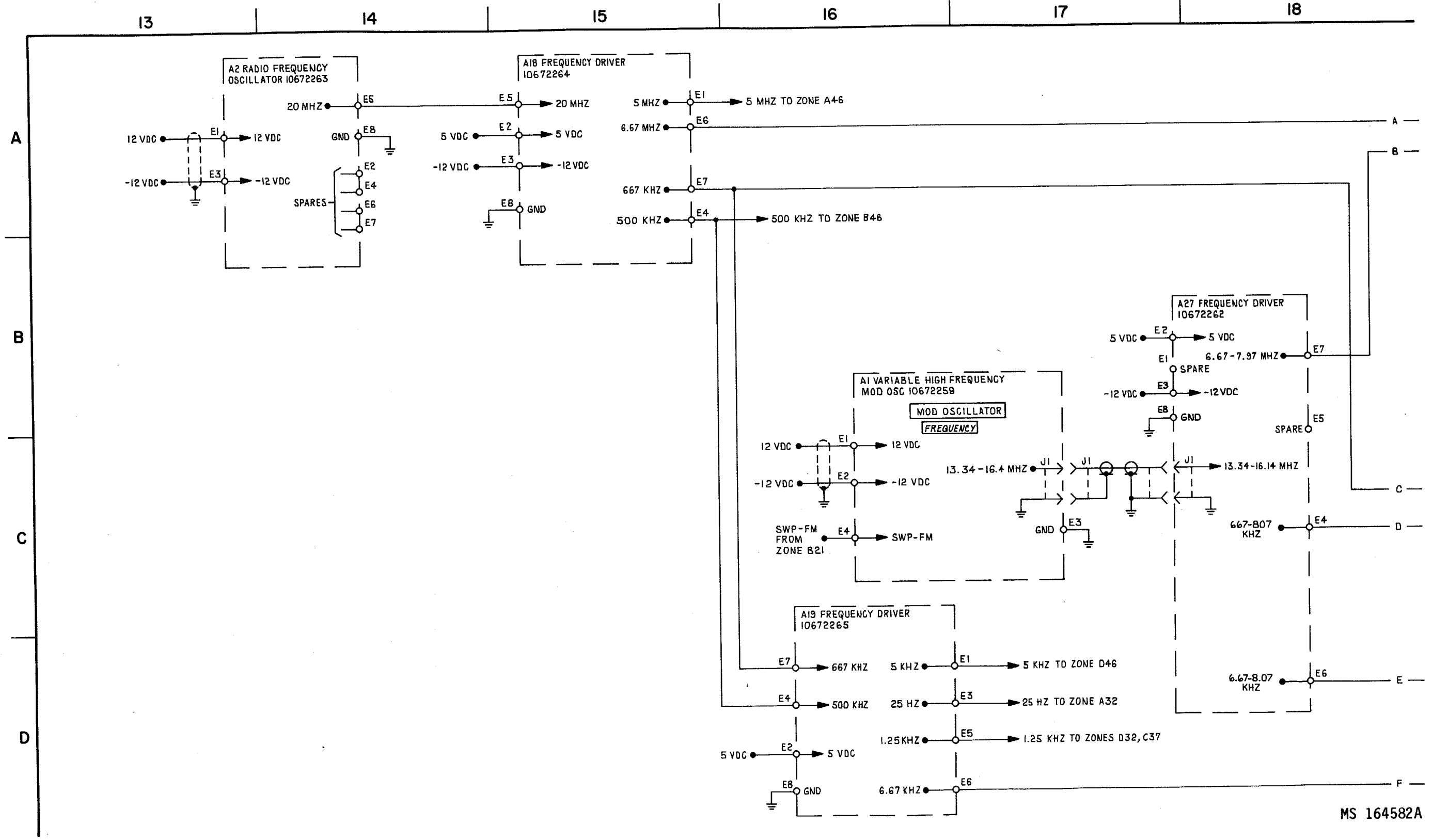

Figure 2-8. Multi-function generator 10182653 (A67) (FG 4000) - schematic (sheet 1 of 9).



MS 164581

Figure 2-8. Multi-function generator 10182653 (A67) (FG 4000) - (sheet 2 of 9).



MS 164582A

Figure 2-8. Multifunction generator 10182653 (A67) (FG 4000) - (sheet 3 of 9)

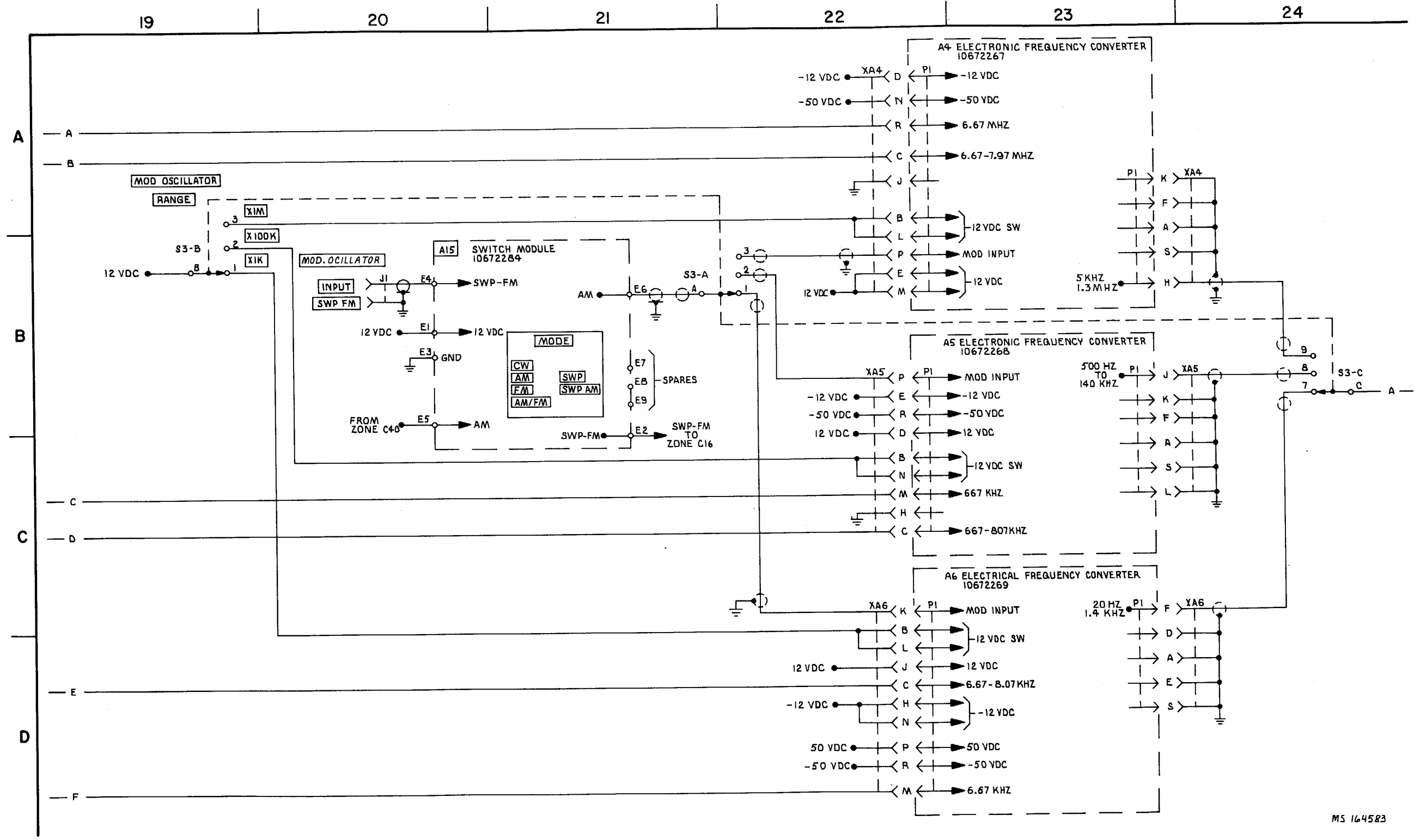

MS 164523

Figure 2-8. Multifunction generator 10182653 (A67) (FG 4000) - (sheet 4 of 9)

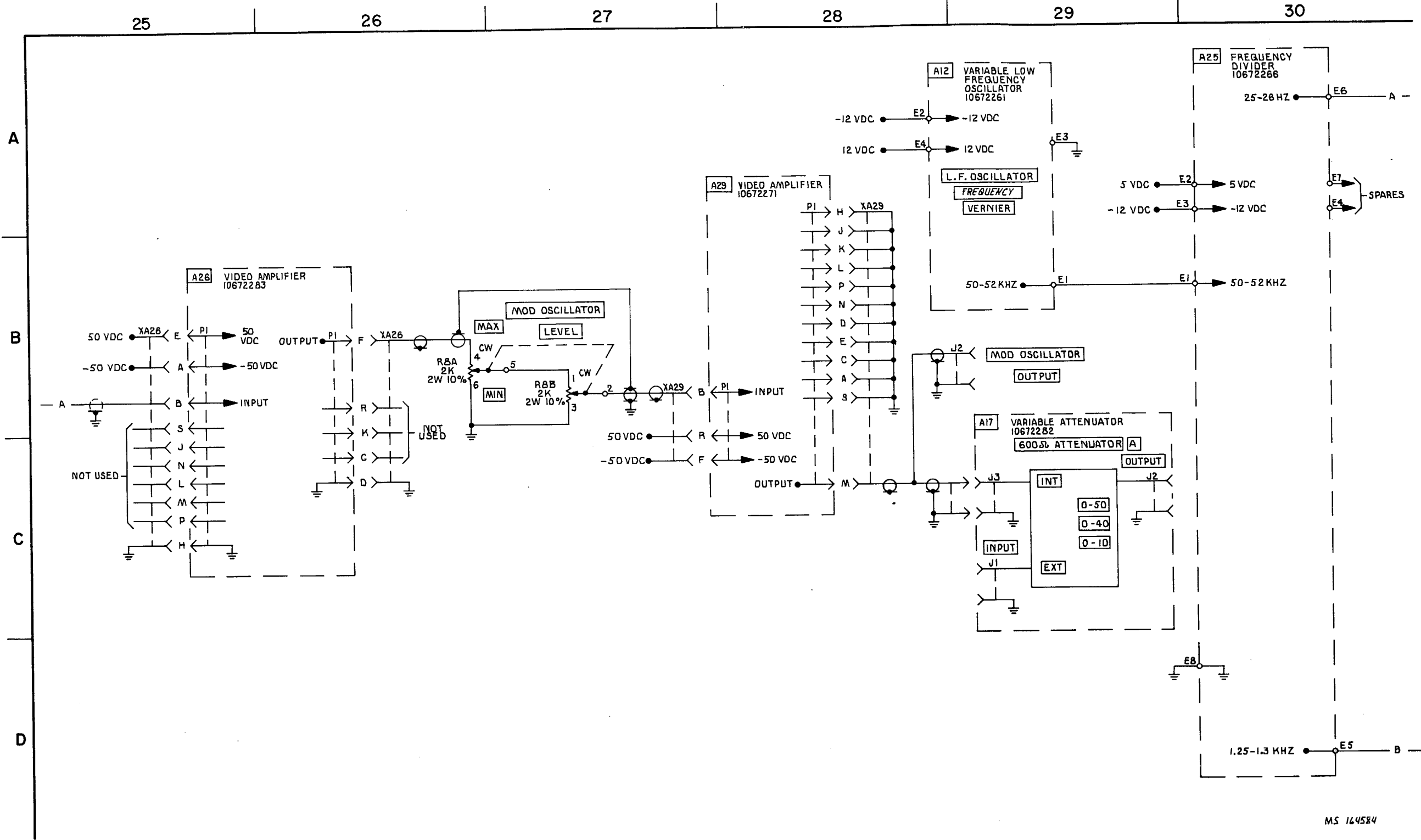

Figure 2-8. Multi-function generator 10182653 (A67) (FG 4000) - (sheet 5 of 9)

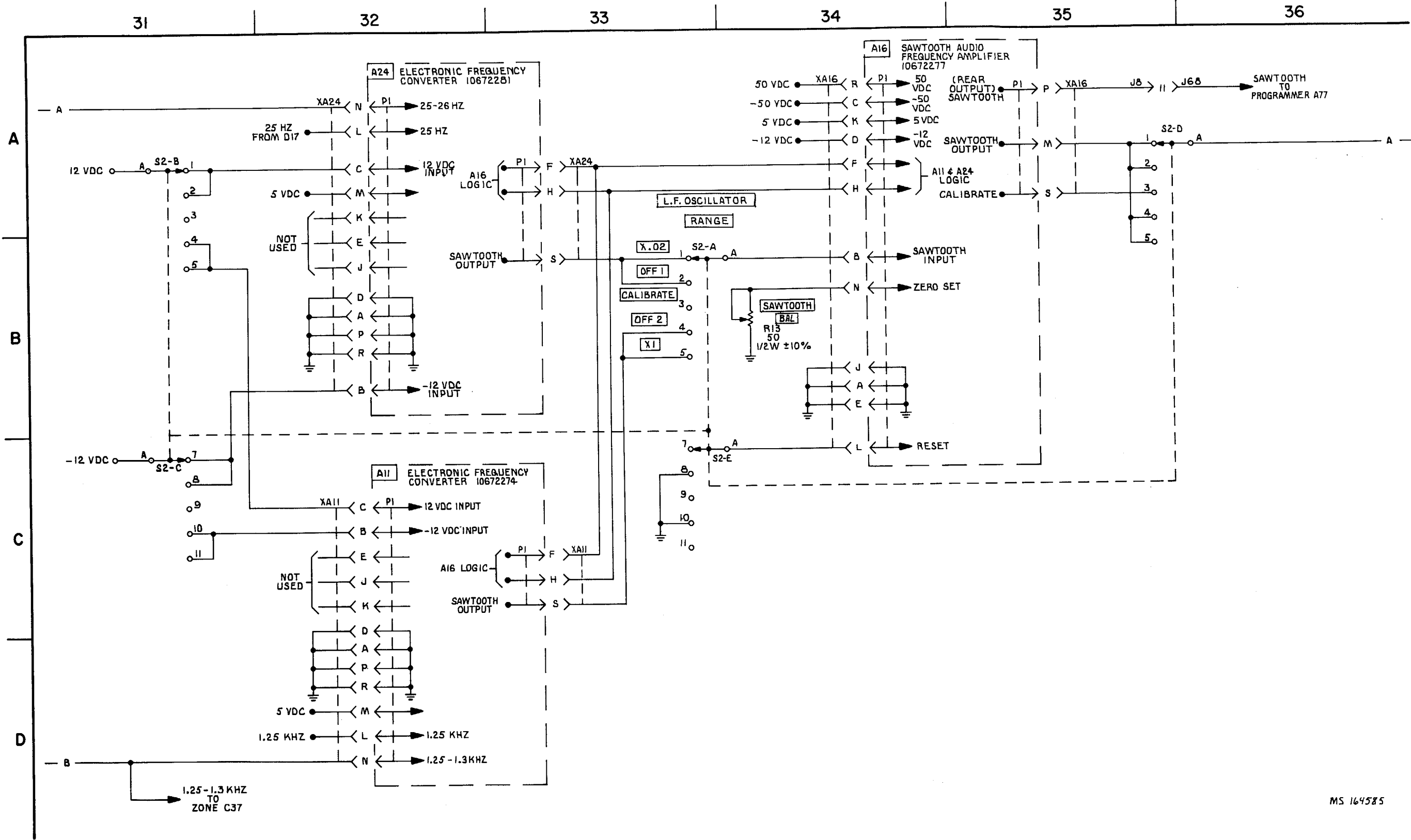

Figure 2-8. Multi-function generator 10182653 (A67) (FG 4000) - (sheet 6 of 9)

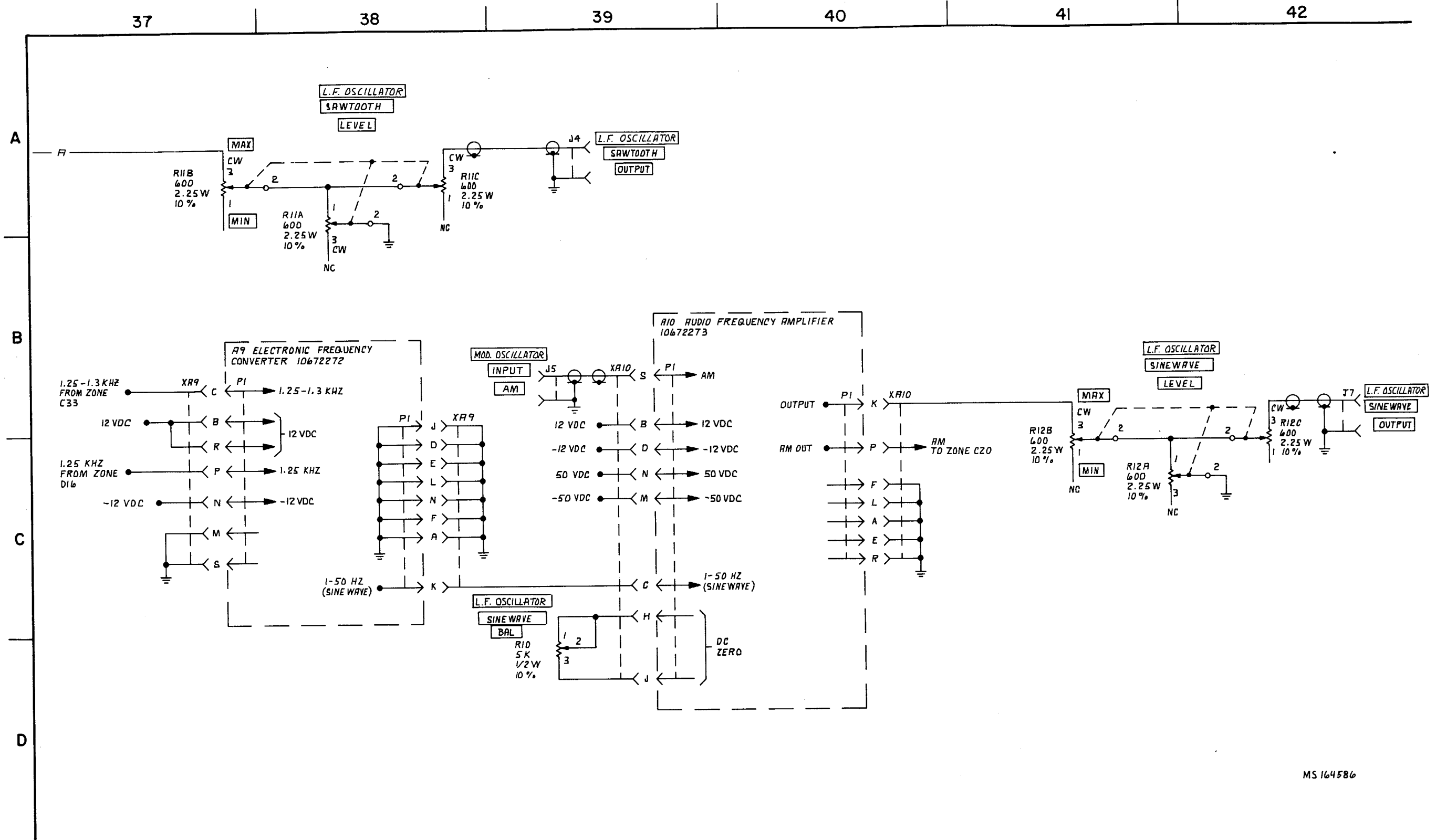
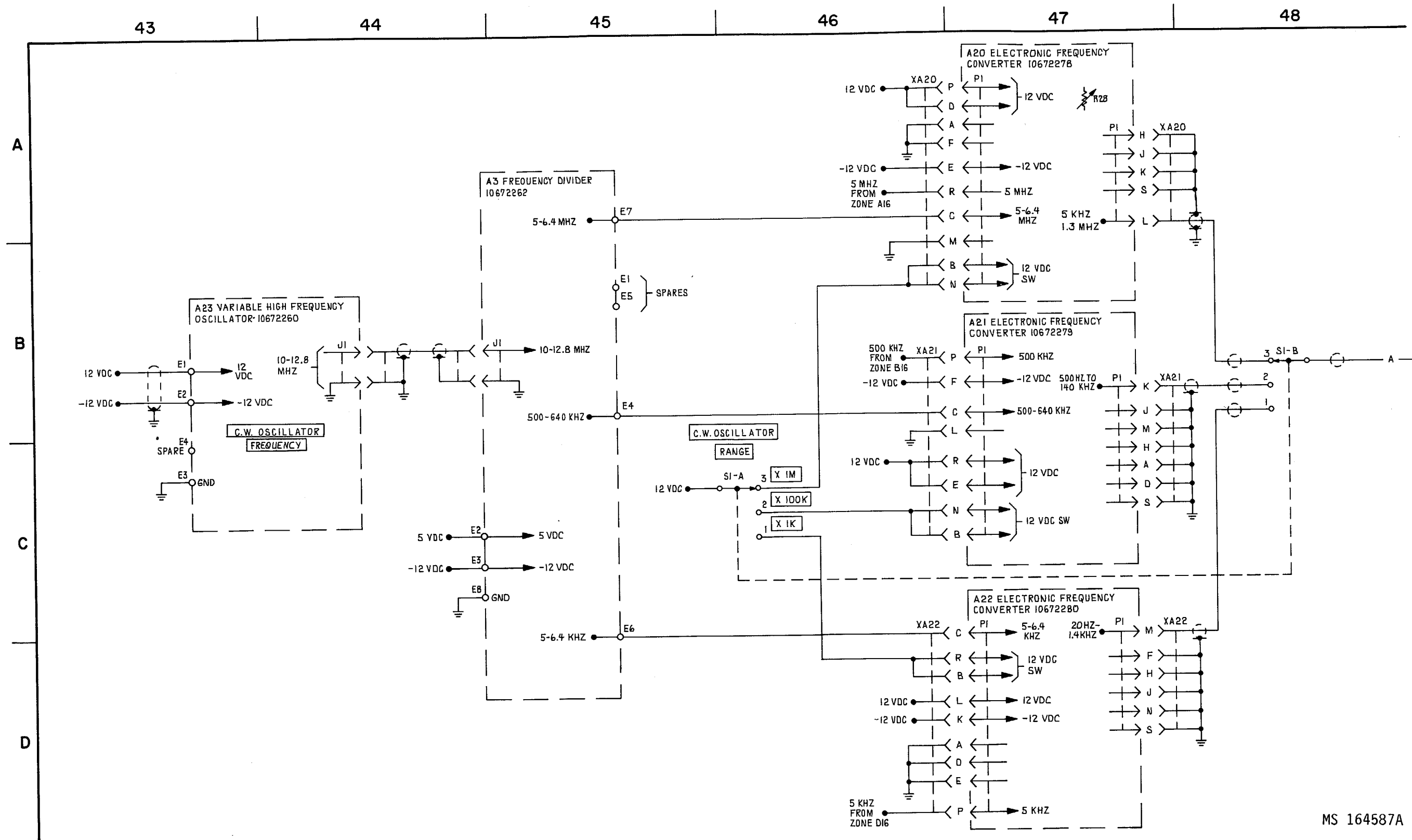

Figure 2-8. Multifunction generator 10182653 (A67) (FG 4000) - (sheet 7 of 9)

MS 164586



MS 164587A

Figure 2-8. Multifunction generator 10182653 (A67) (FG 4000) - (sheet 8 of 9)

2-75(2-76 blank)

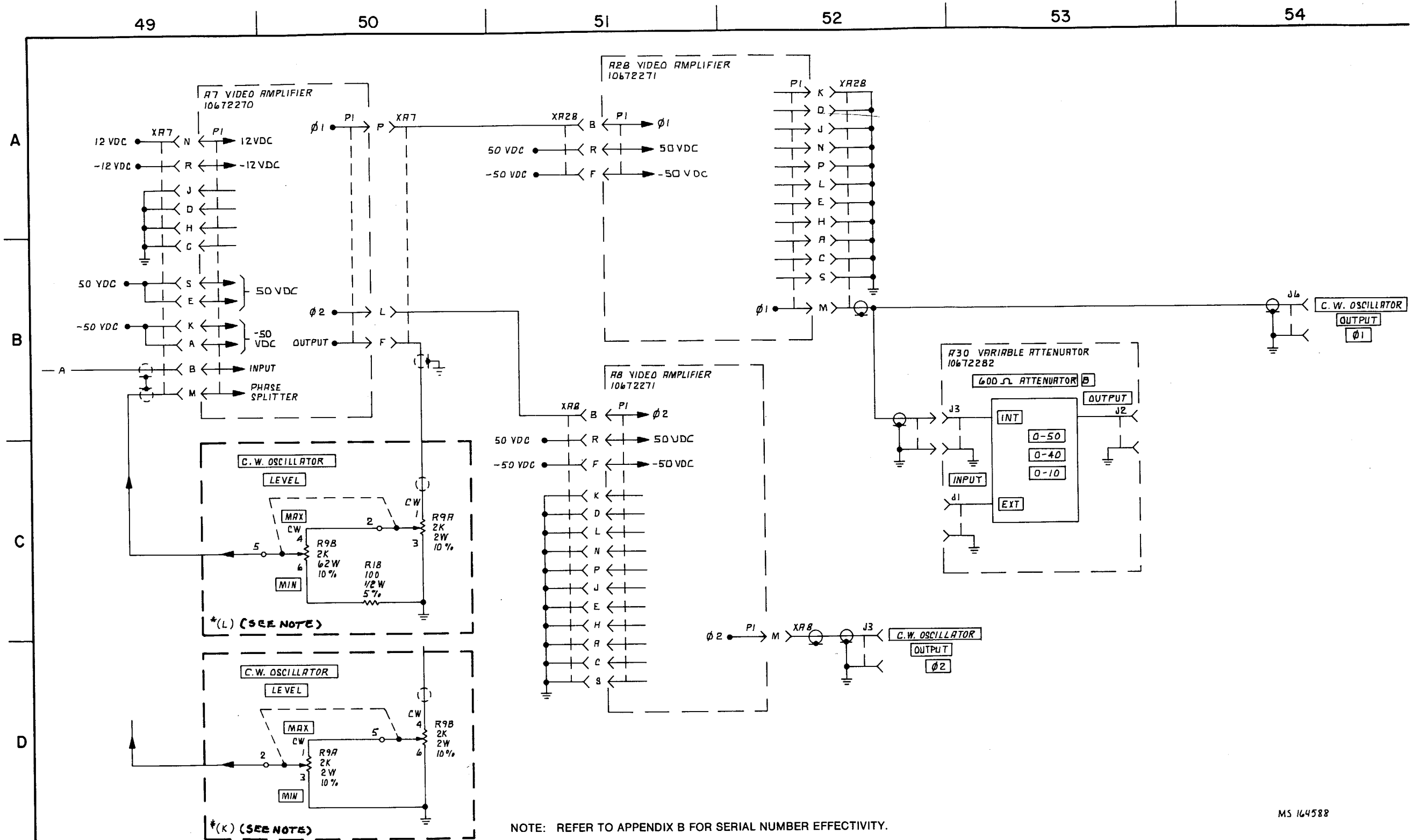

MS 144588

Figure 2-8. Multi-function generator 10182653 (A67) (FG 4000) - (sheet 9 of 9)

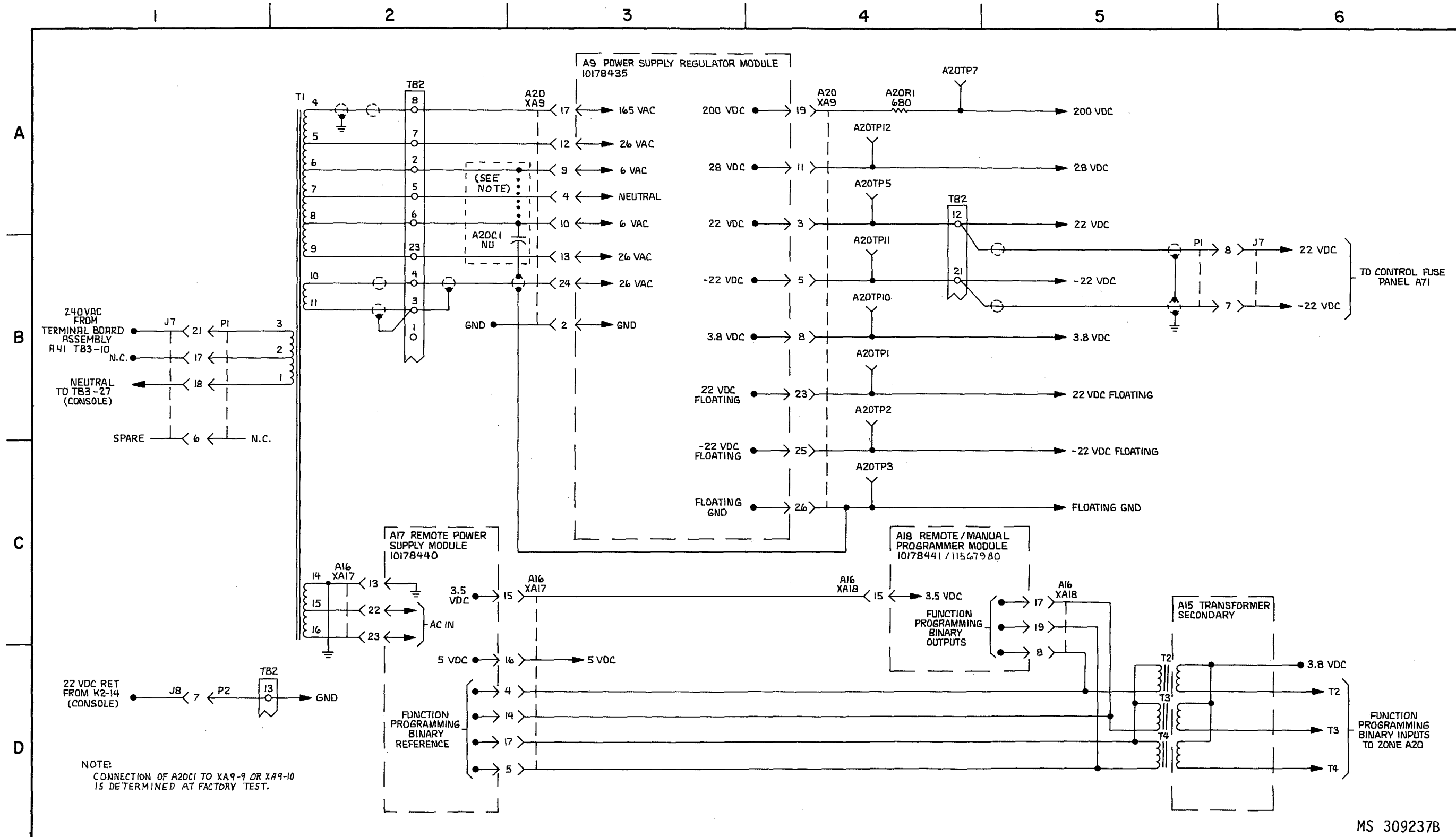
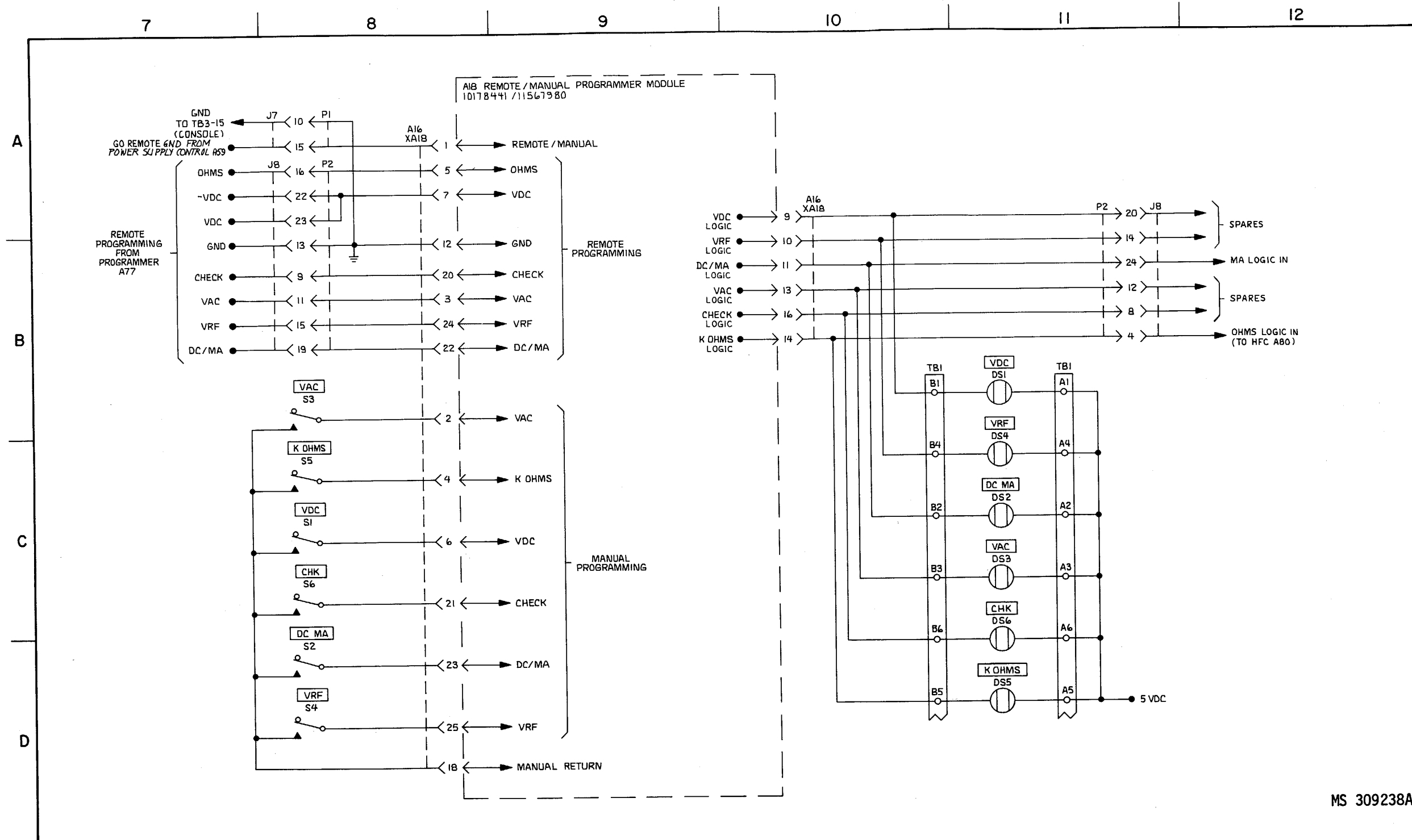

Figure 2-9. Digital multimeter B 11569529 (A58) (FG 4800) - schematic (sheet 1 of 6)

MS 309237B



MS 309238A

Figure 2-9. Digital multimeter B 11569529 (A58) (FG 4800) - schematic (sheet 2 of 6).

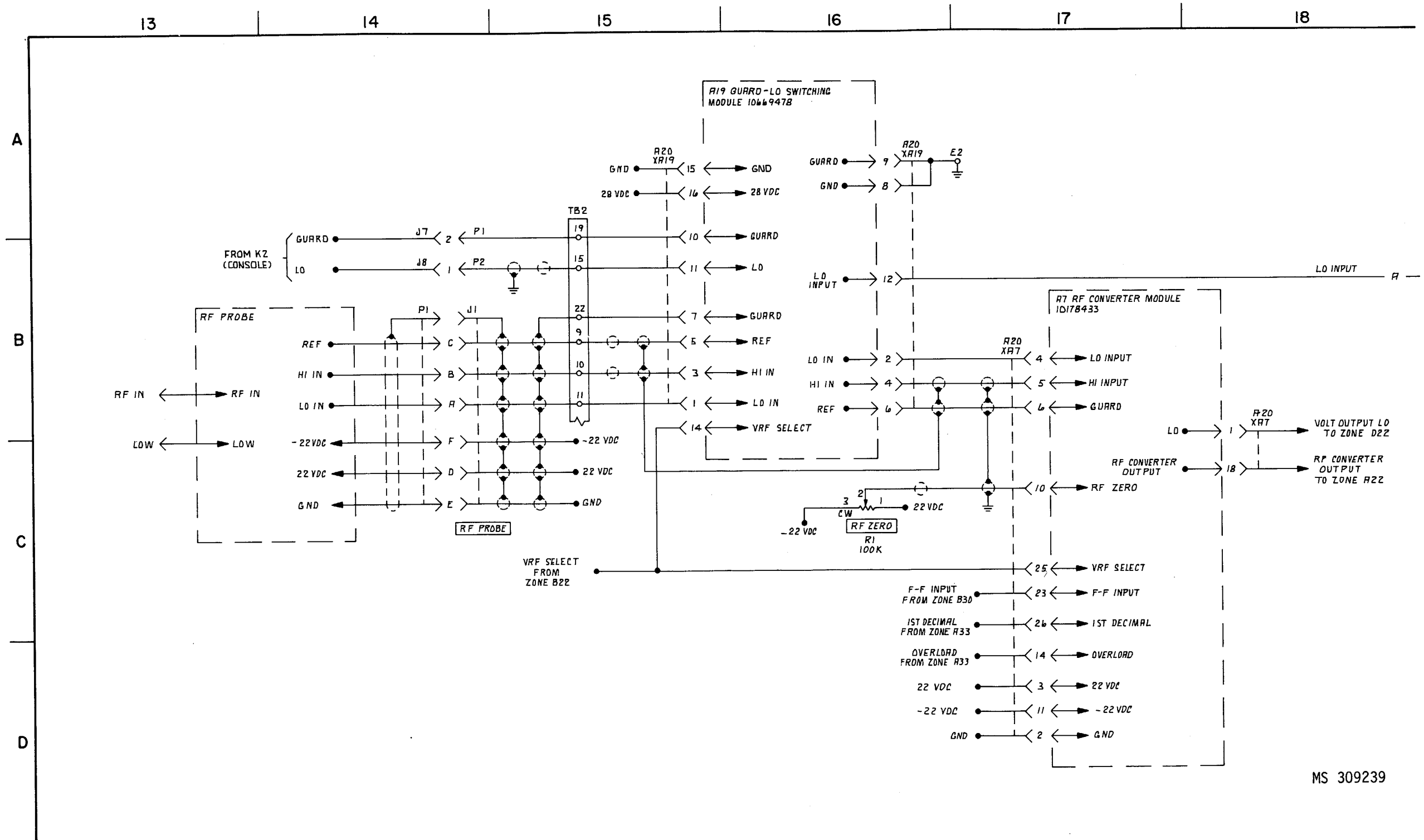

MS 309239

Figure 2-9. Digital multimeter B 11569529 (A58) (FG 4800) - schematic (sheet 3 of 6).

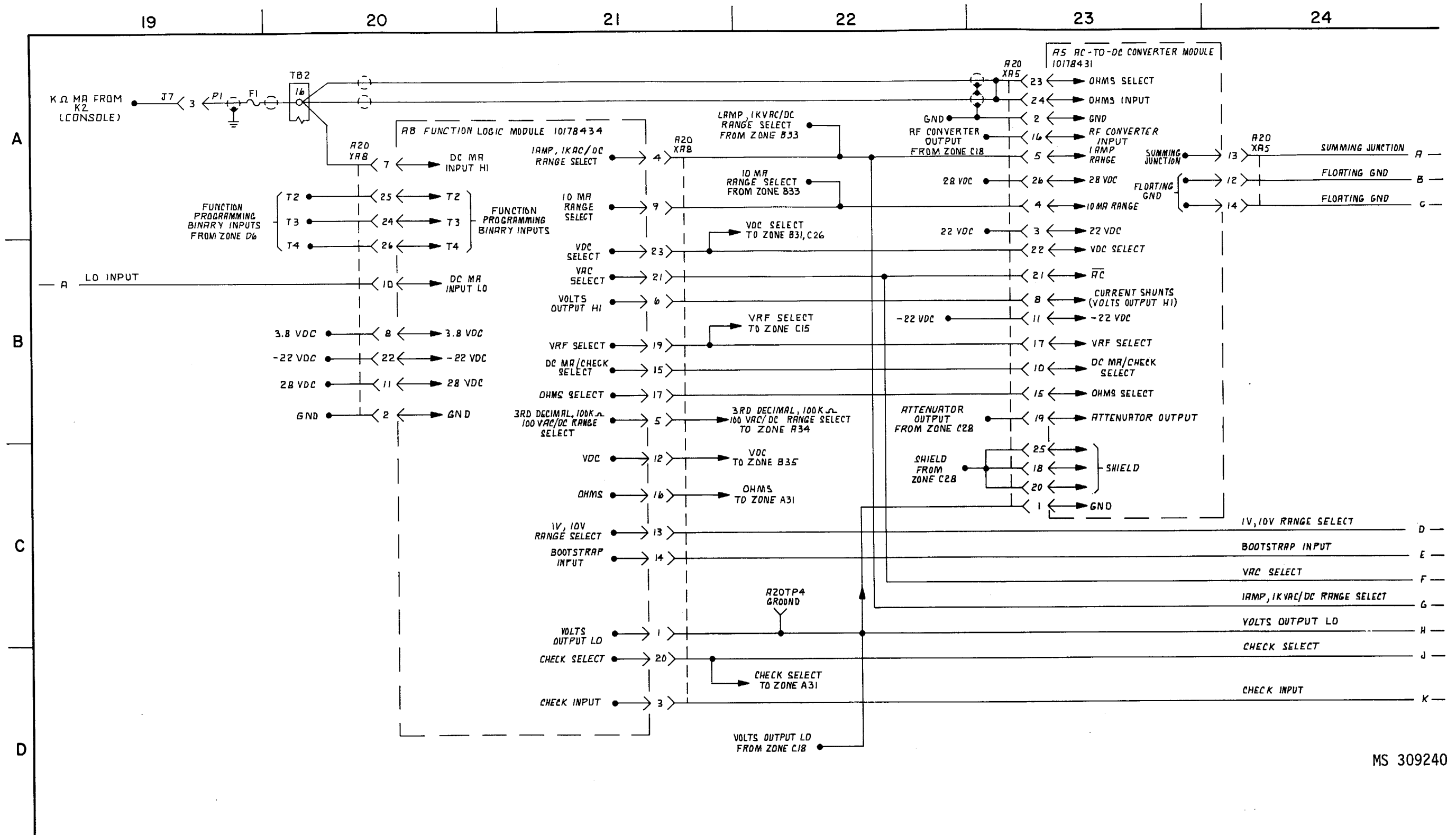

MS 309240

Figure 2-9. Digital multimeter B 11569529 (A58) (FG 4800) - schematic (sheet 4 of 6).

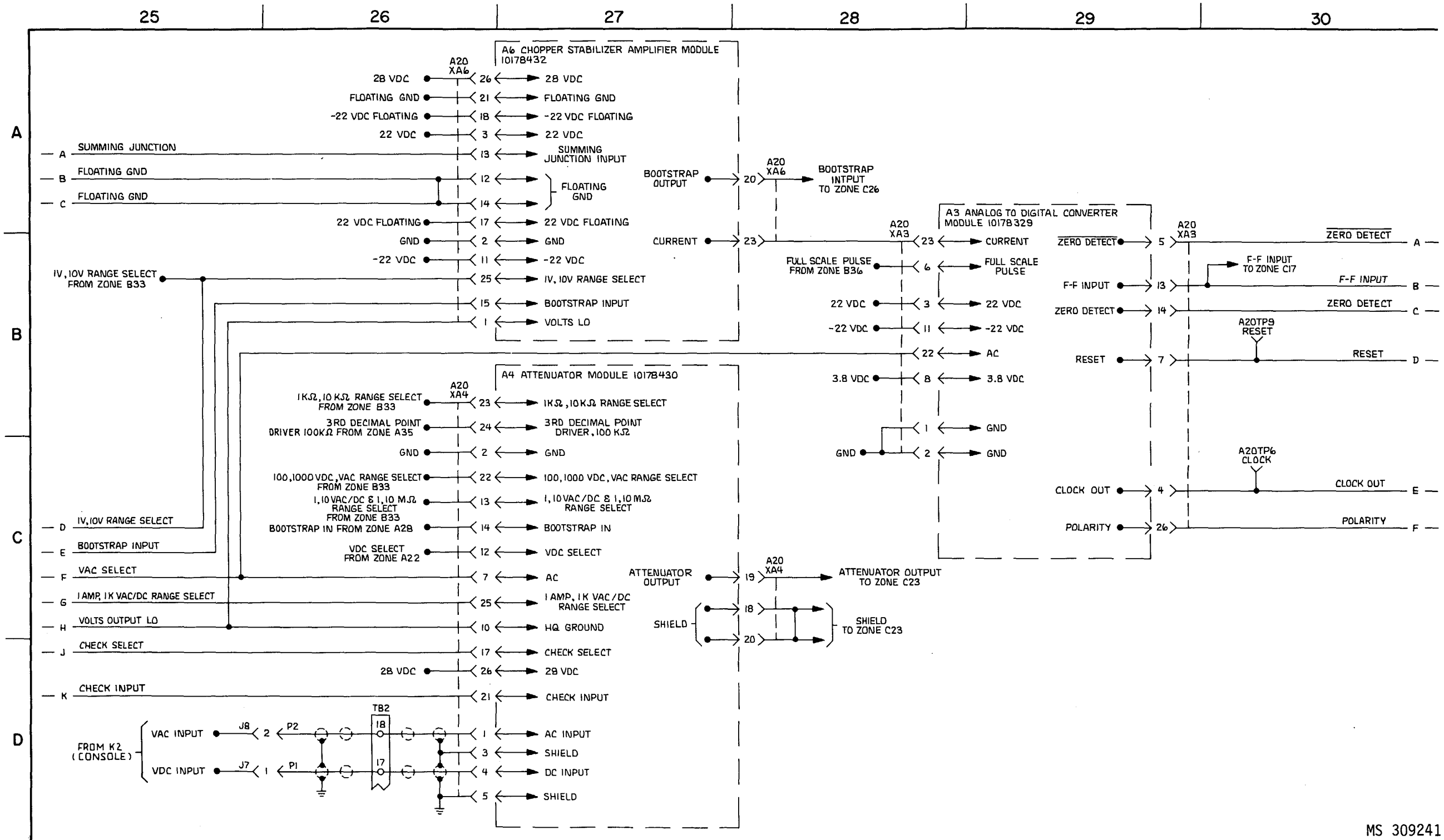

Figure 2-9. Digital multimeter B 11569529 (A58) (FG 4800) - schematic (sheet 5 of 6).

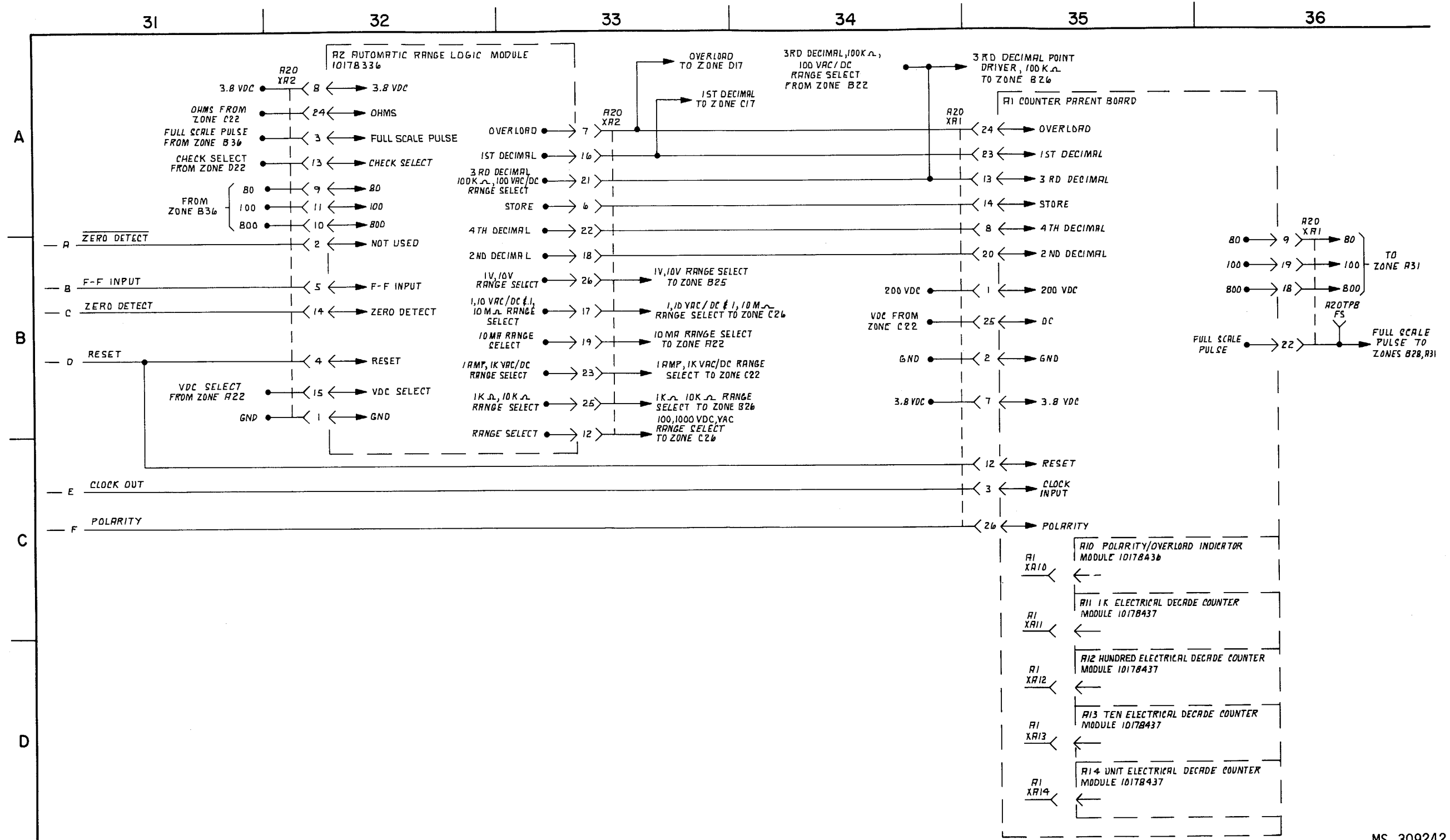

Figure 2-9. Digital multimeter B 11569529 (A58) (FG 4800) - schematic (sheet 6 of 6).

MS 309242

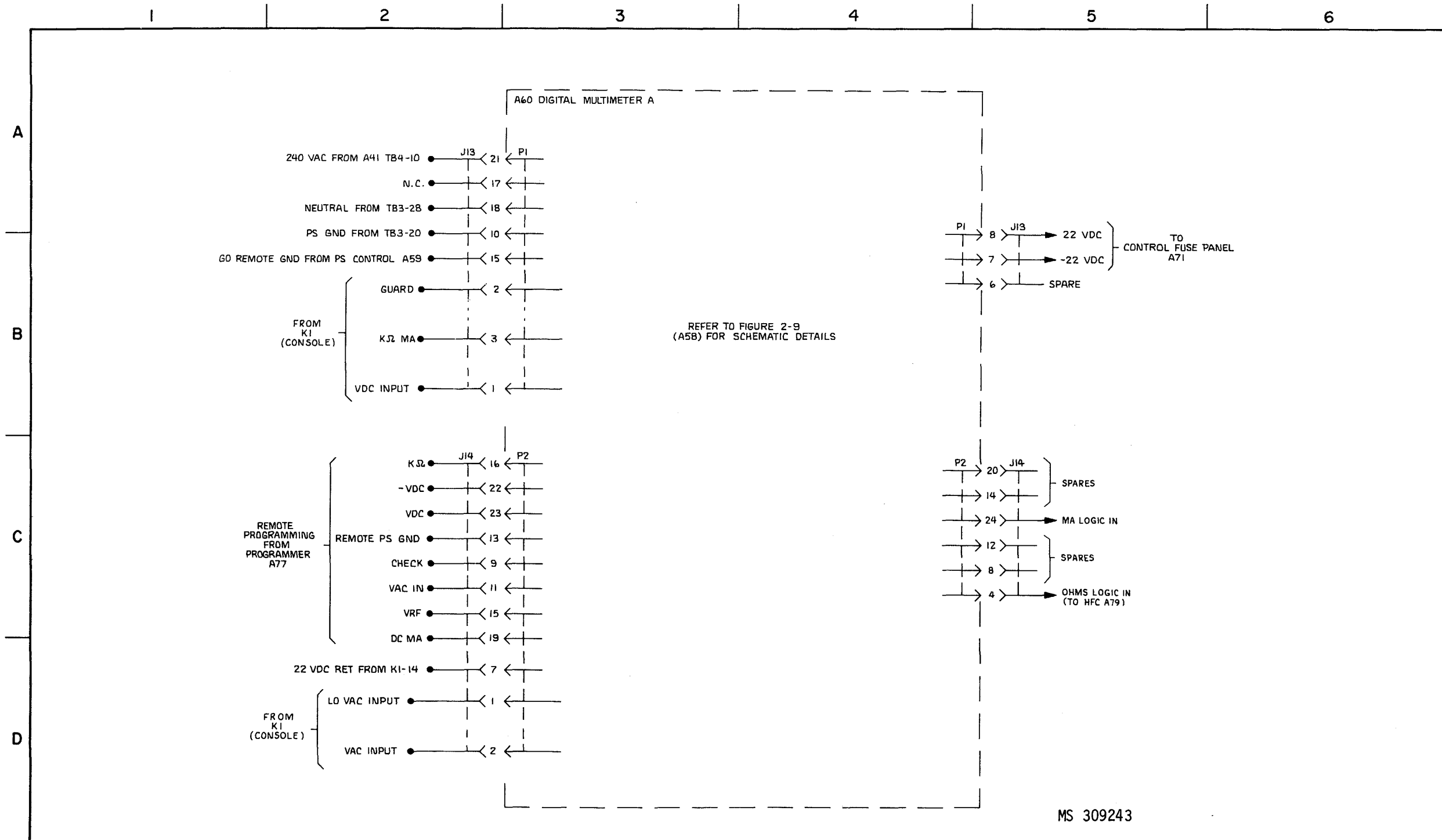
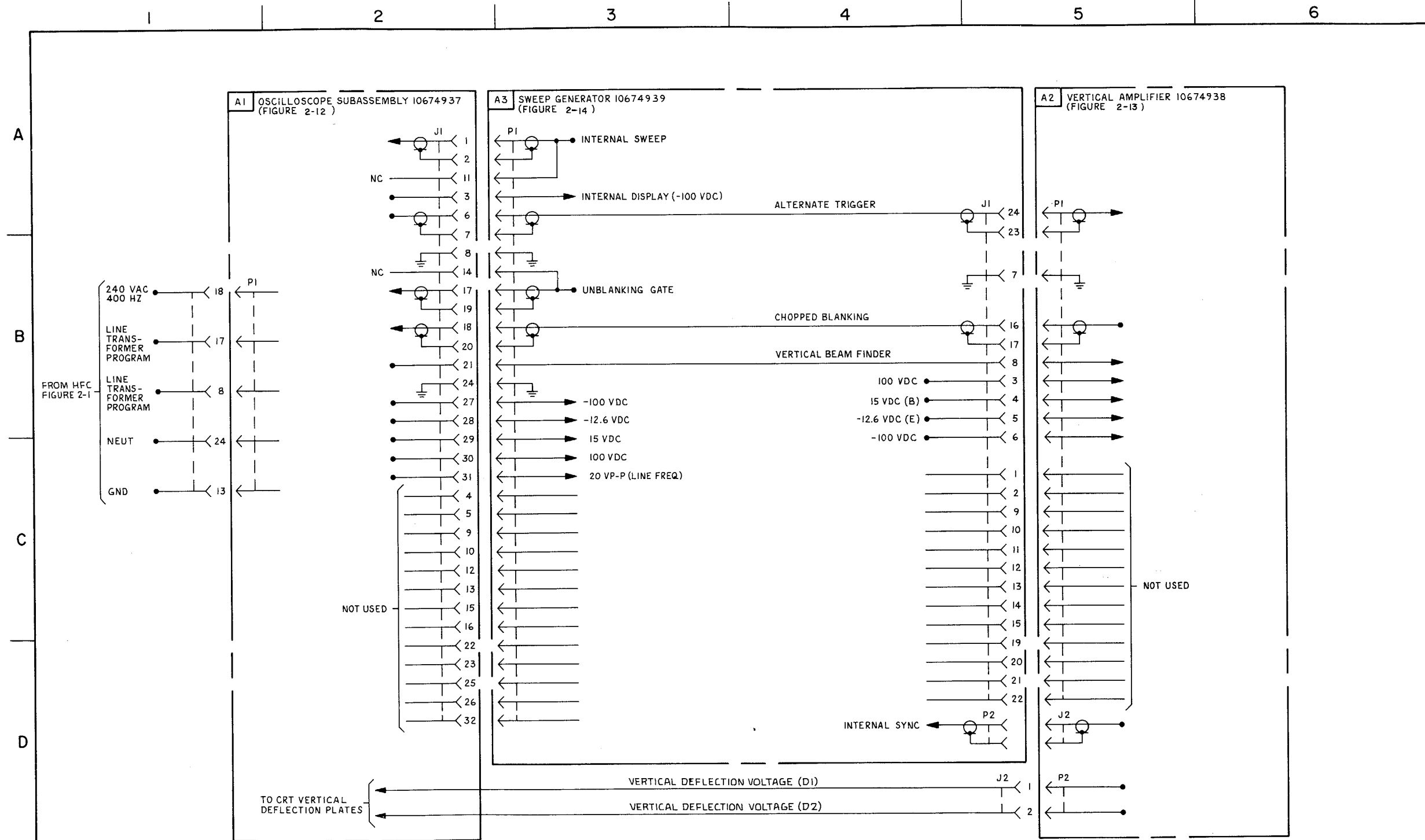

Figure 2-10. Digital multimeter A 11569529 (A60) (FG 4800) - schematic.



MS 309244

Figure 2-11. Oscilloscope 10182656 (A61) (FG 5000) - interconnecting diagram.

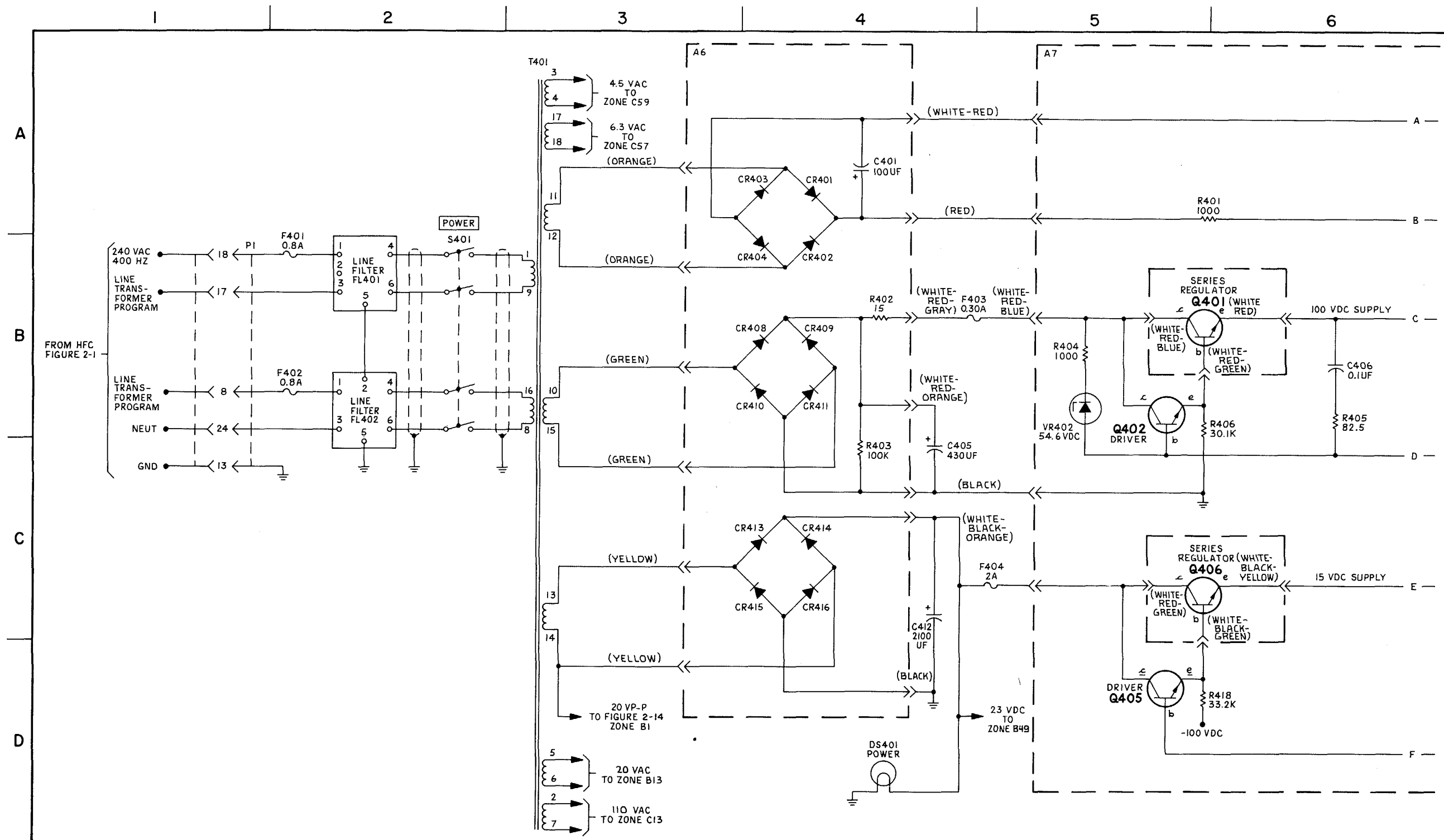

Figure 2-12. Oscilloscope subassembly 10674937 (A61A1) (FG 5050) - schematic (sheet 1 of 10).

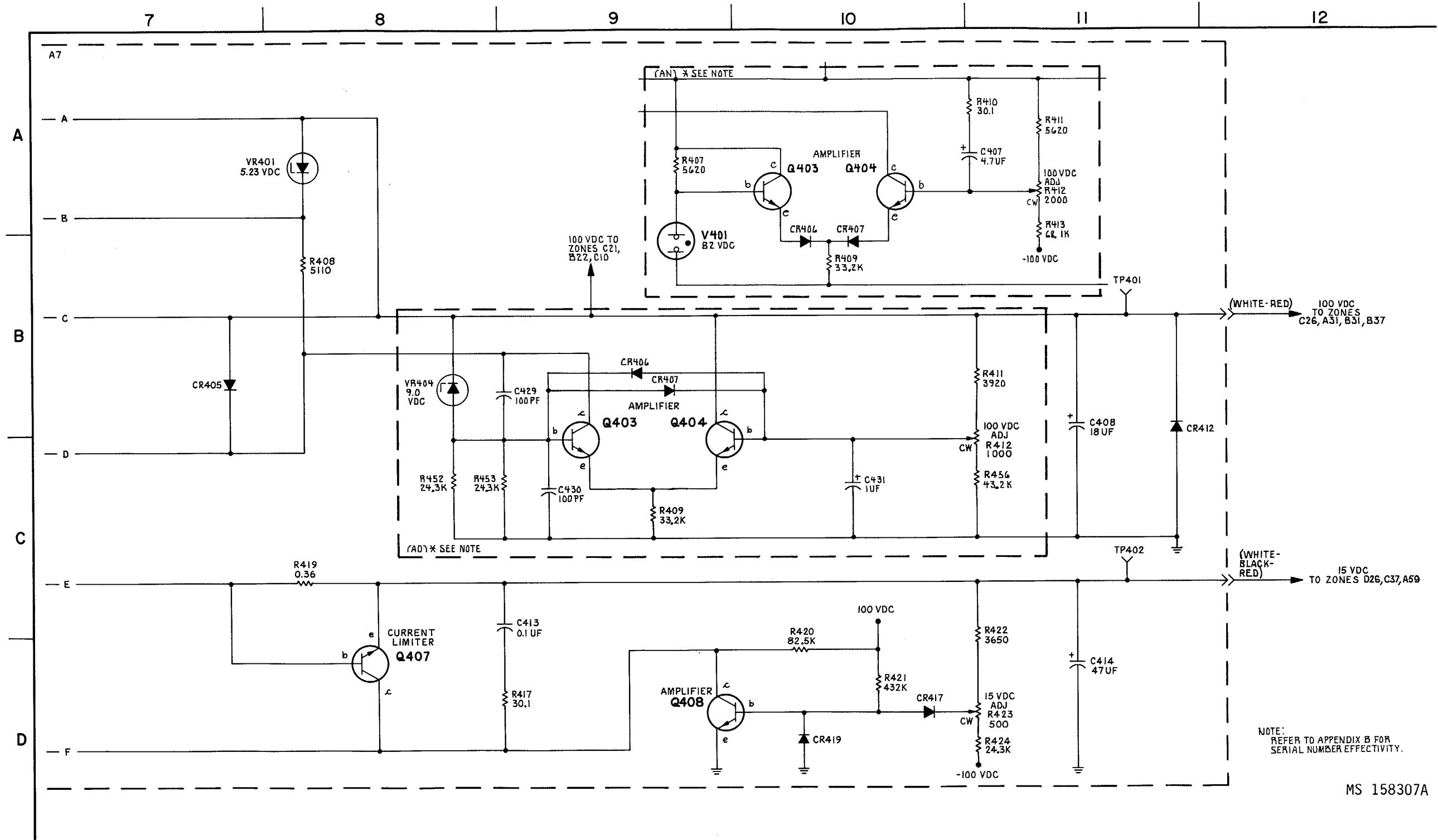

Figure 2-12. Oscilloscope subassembly 10674937 (A61A1) (FG 5050) - schematic (sheet 2 of 10).

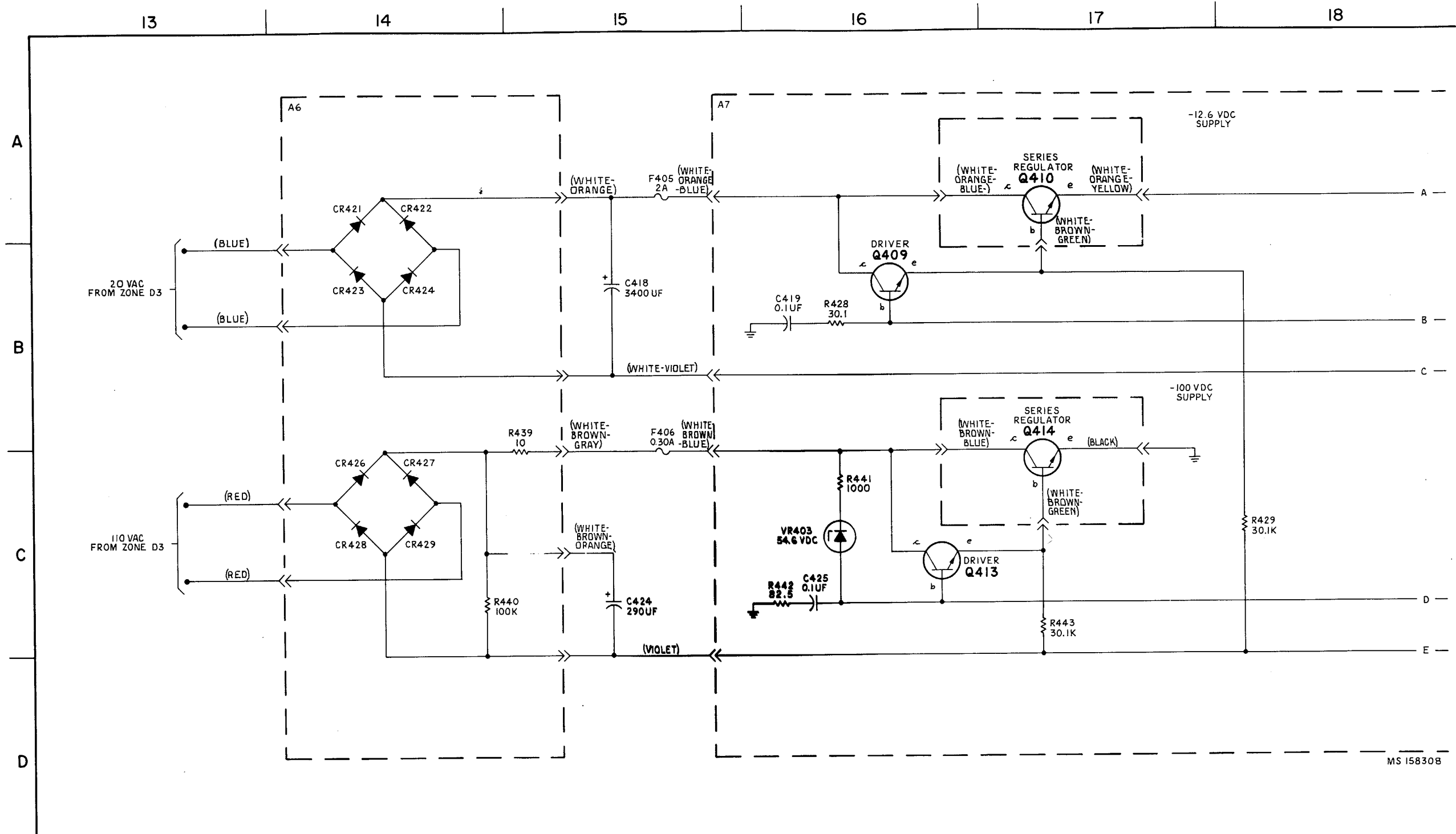
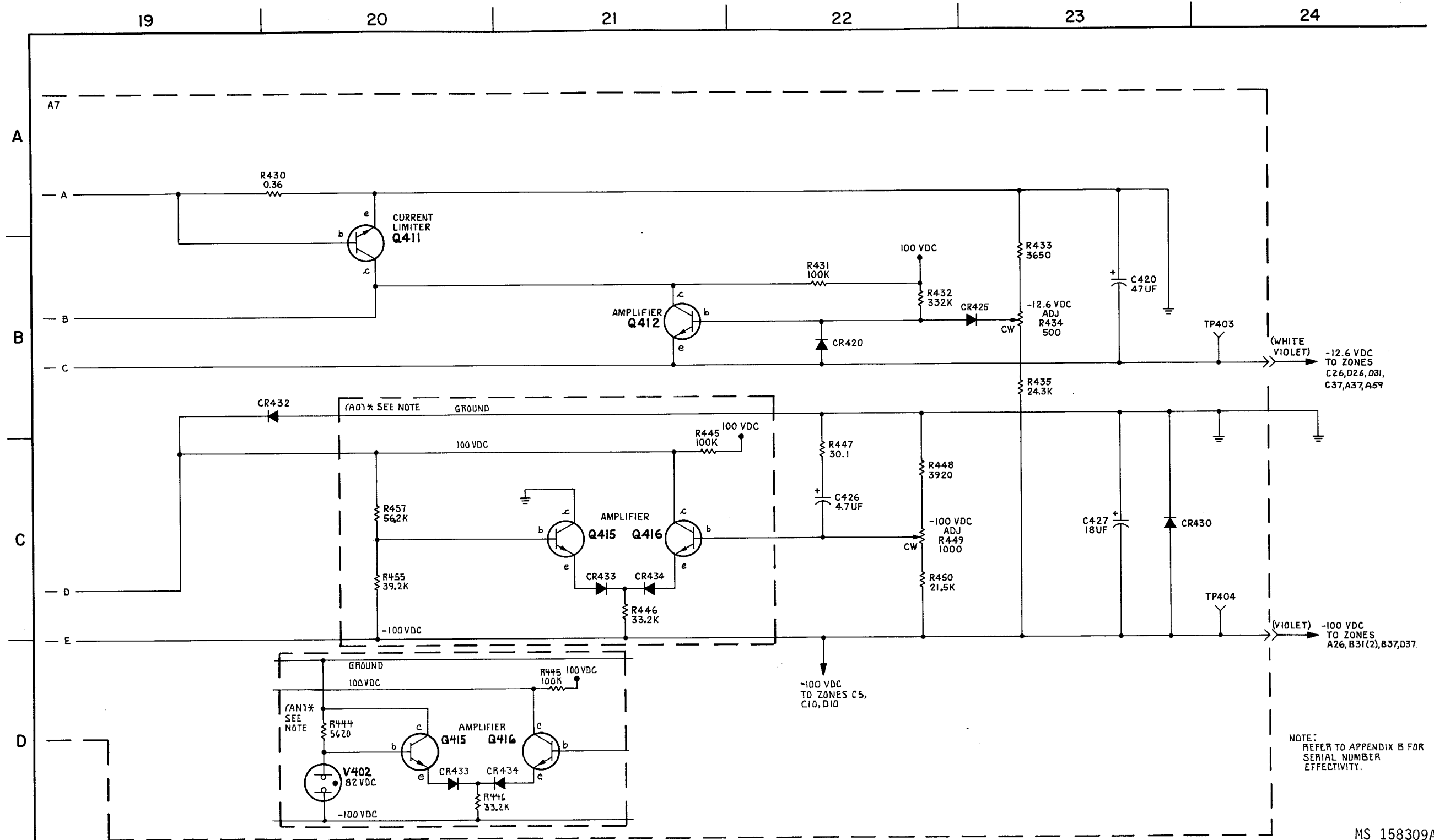

Figure 2-12. Oscilloscope subassembly 10674937 (A61A1) (FG 5050) - schematic (sheet 3 of 10).



MS 158309A

Figure 2-12. Oscilloscope subassembly 10674937 (A61A1) (FG 5050) - schematic (sheet 4 of 10).

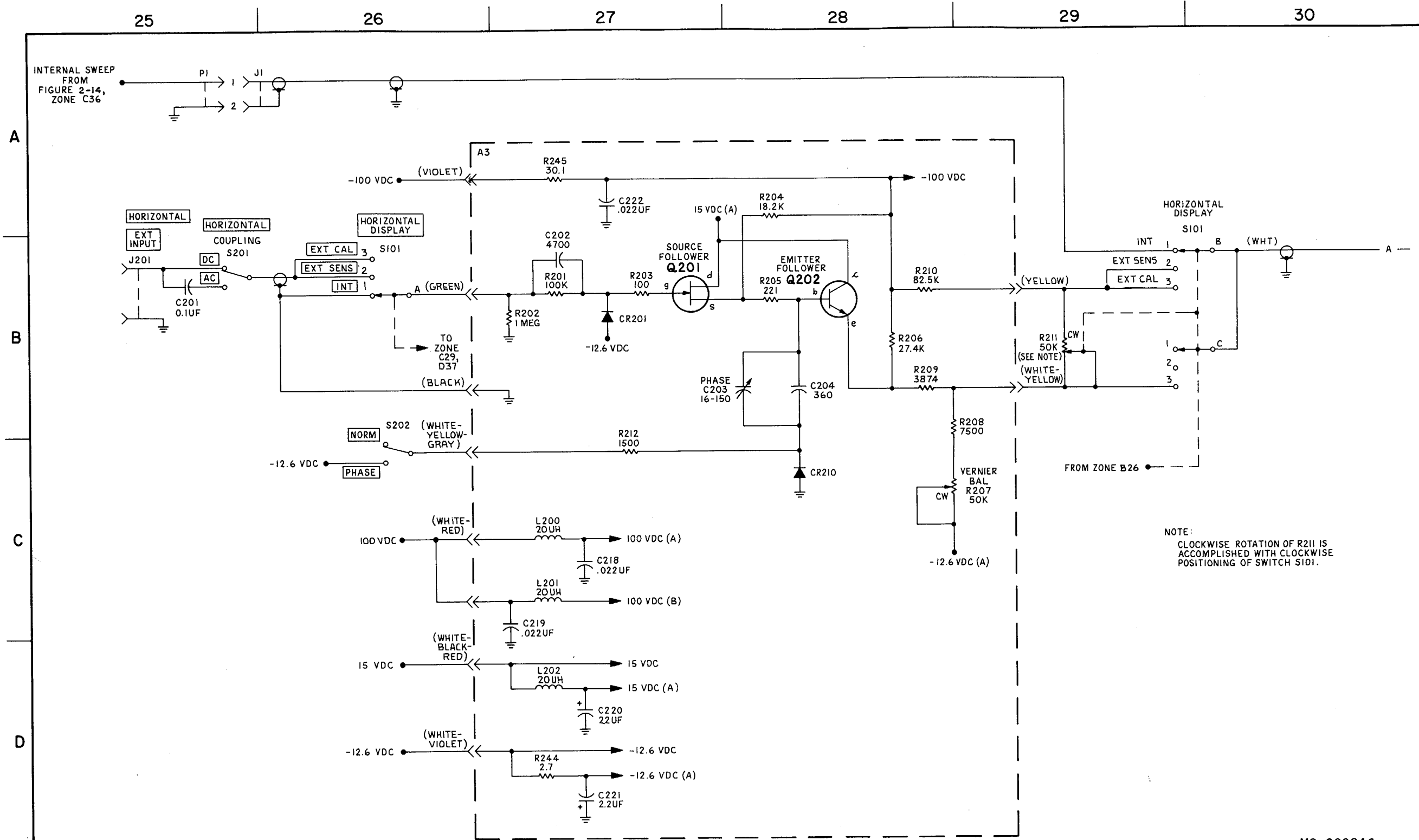
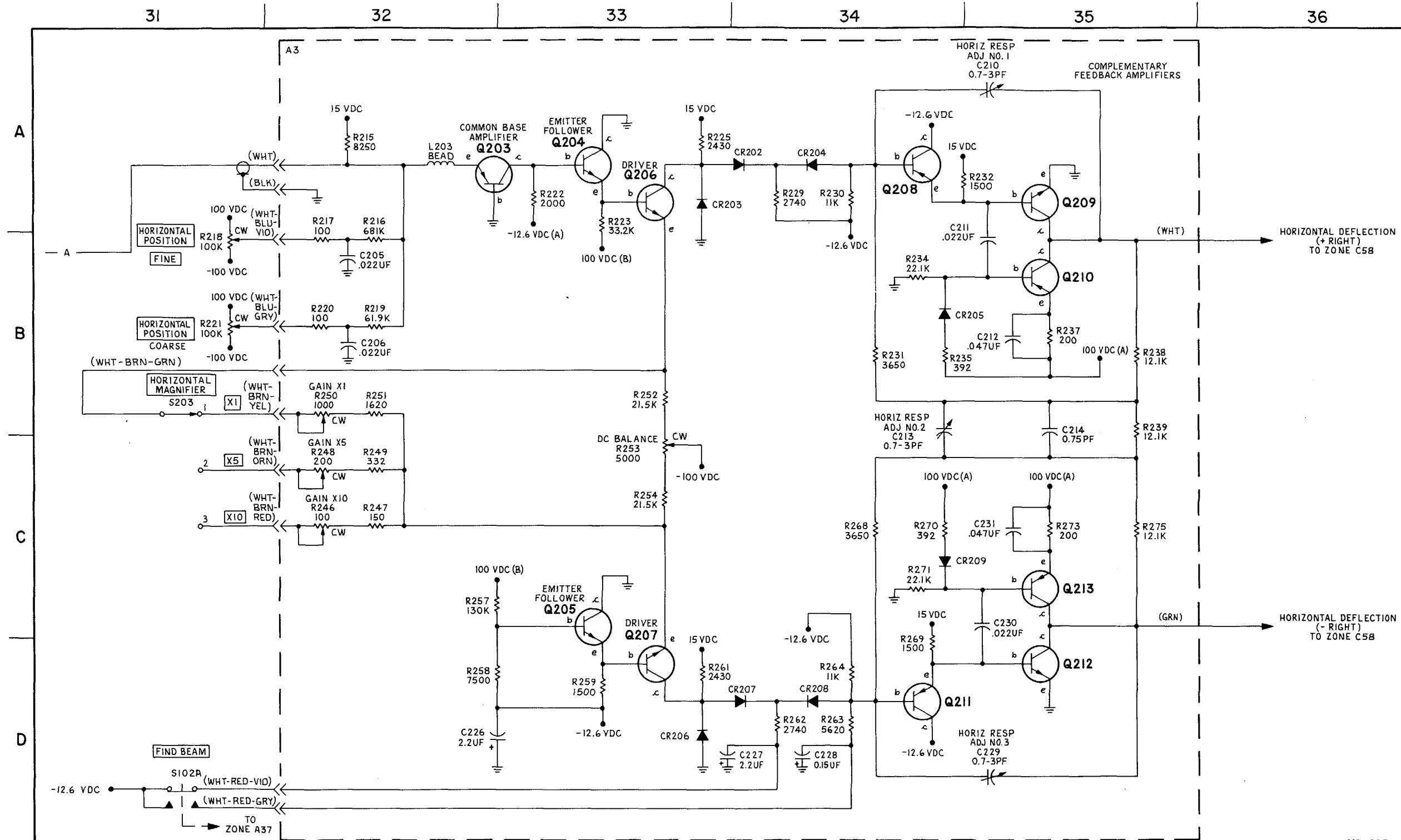

Figure 2-12. Oscilloscope subassembly 10685937 (A61A1) (FG 5050) - schematic (sheet 5 of 10)

MS 309246



MS 158311

Figure 2-12. Oscilloscope subassembly 10685937 (A61A1) (FG 5050) - schematic (sheet 6 of 10)

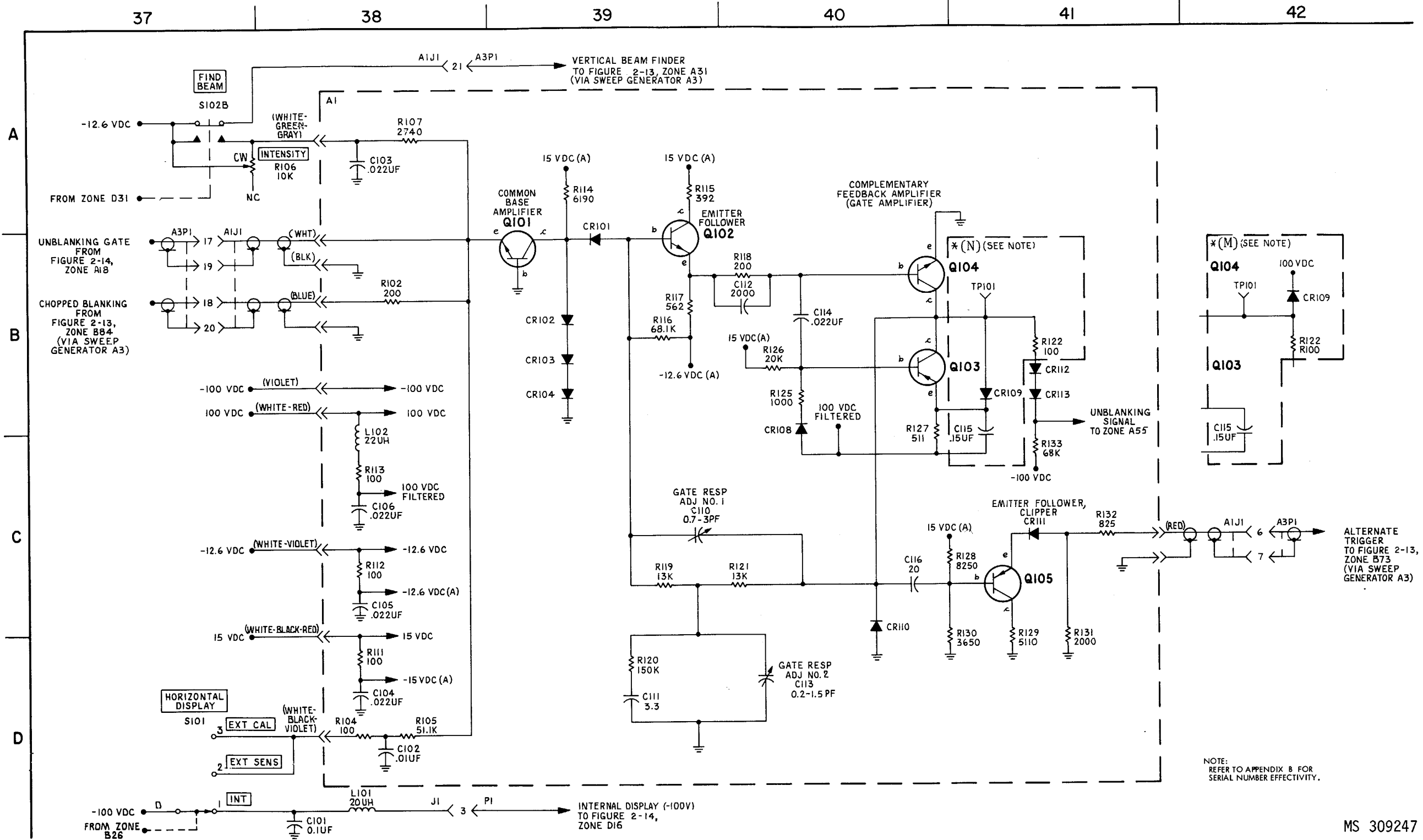
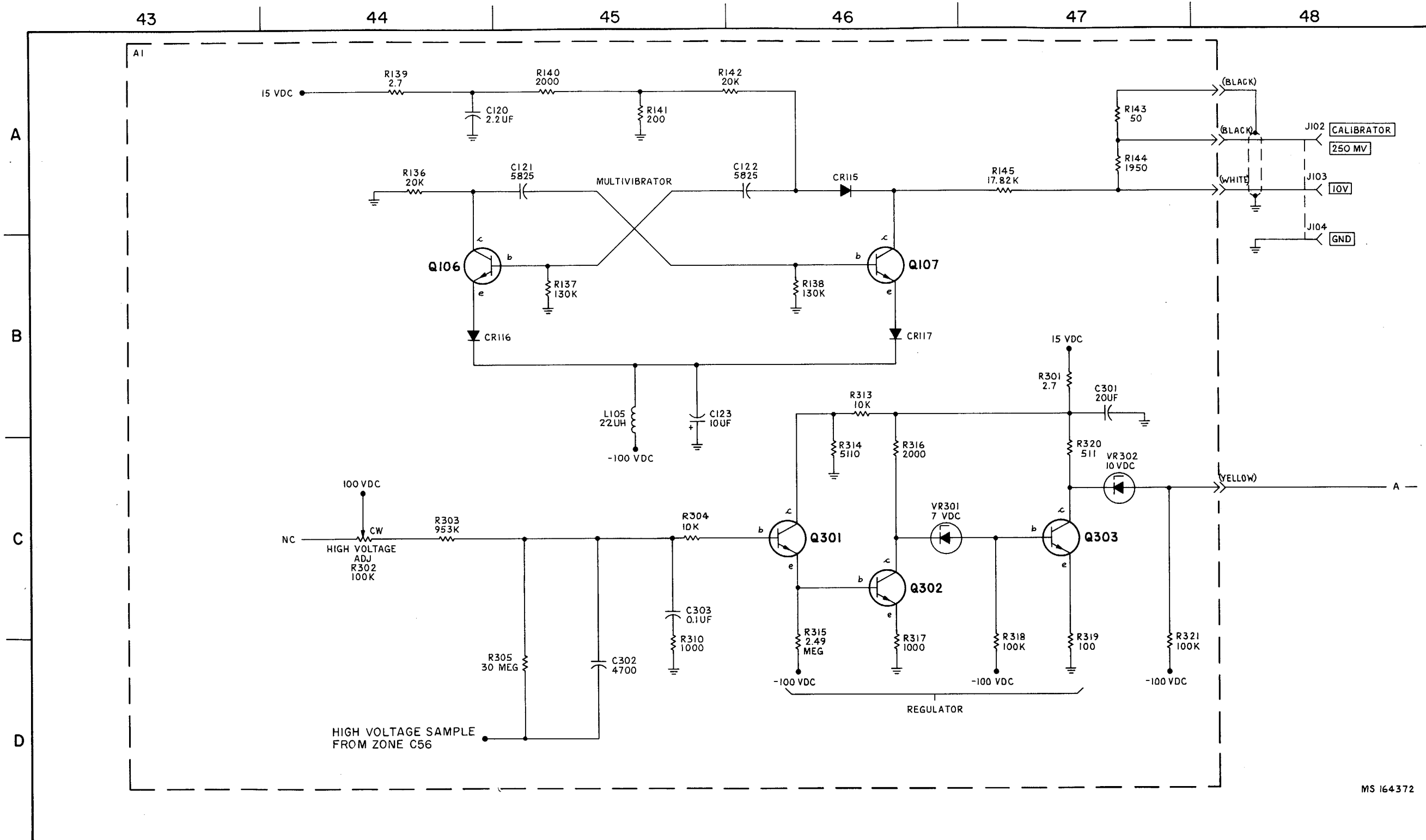
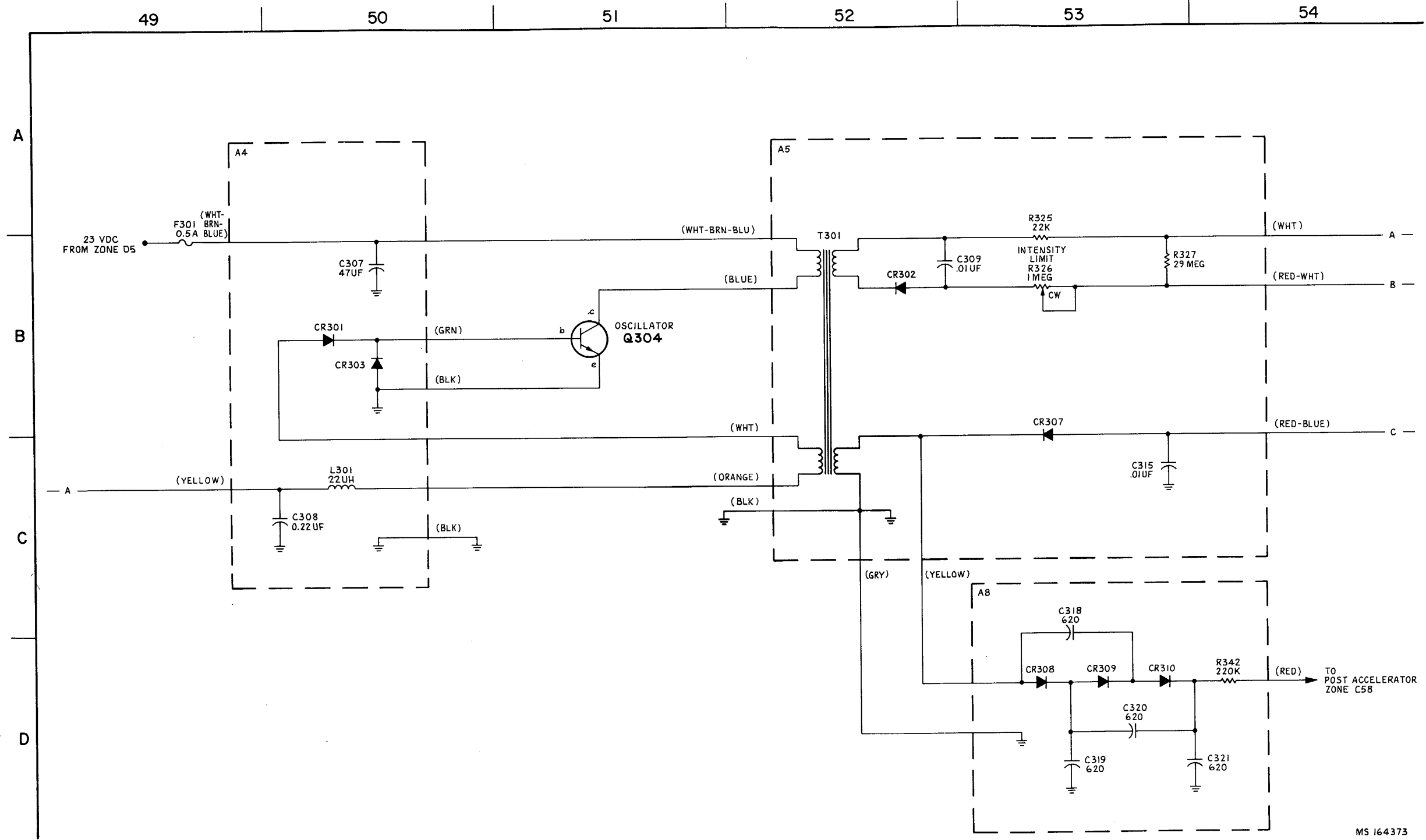

Figure 2-12. Oscilloscope subassembly 10685937 (A61A1) (FG 5050) - schematic (sheet 7 of 10)



MS 164372

Figure 2-12. Oscilloscope subassembly 10685937 (A61A1) (FG 5050) - schematic (sheet 8 of 10)



MS 164373

Figure 2-12. Oscilloscope subassembly 10685937 (A61A1) (FG 5050) - schematic (sheet 9 of 10)

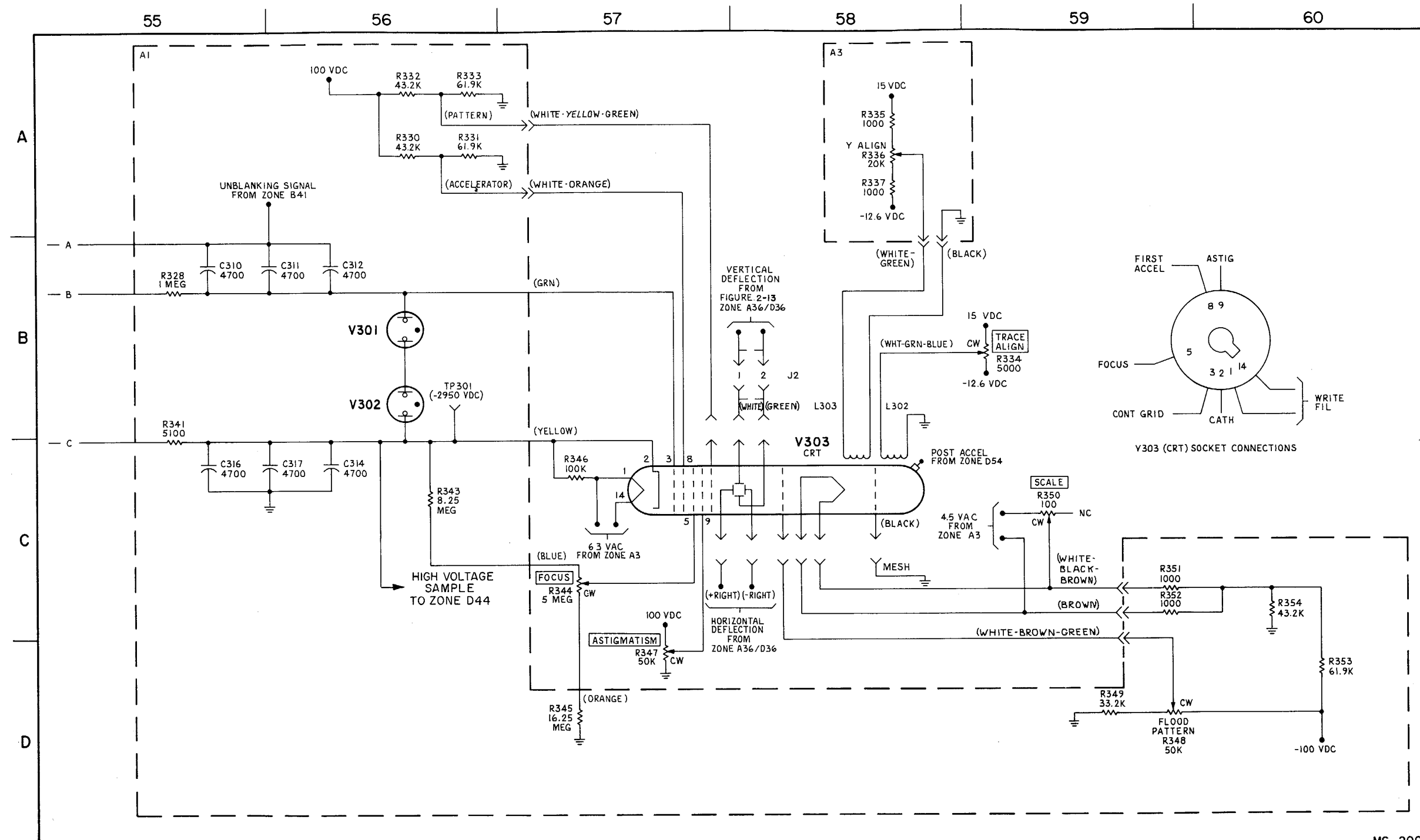

MS 309248

Figure 2-12. Oscilloscope subassembly 10685937 (A61A1) (FG 5050) - schematic (sheet 10 of 10)

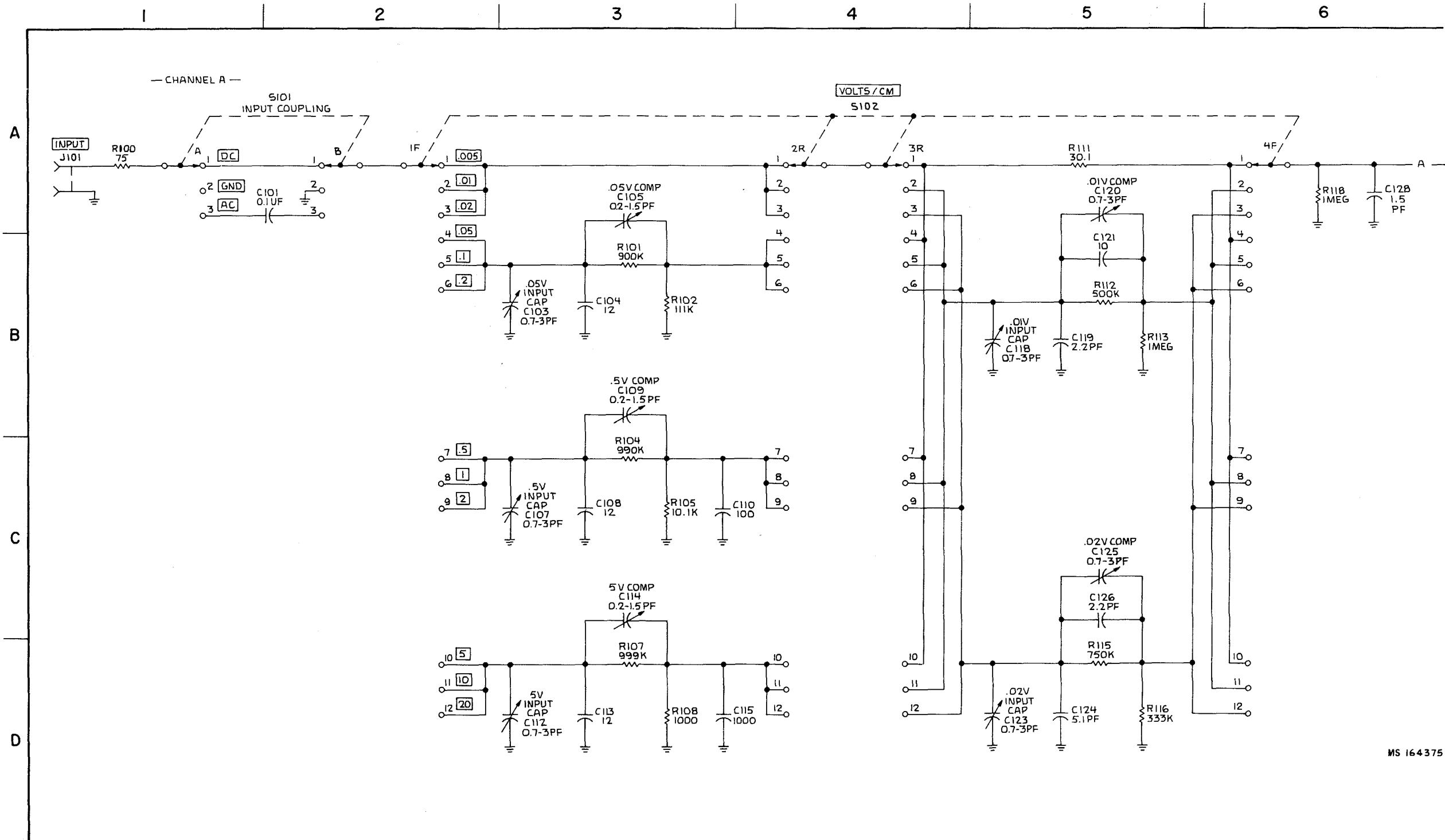

MS 164375

Figure 2-13. Oscilloscope vertical amplifier 10674938 (A61A2) (FG 5100) - schematic (sheet 1 of 14)

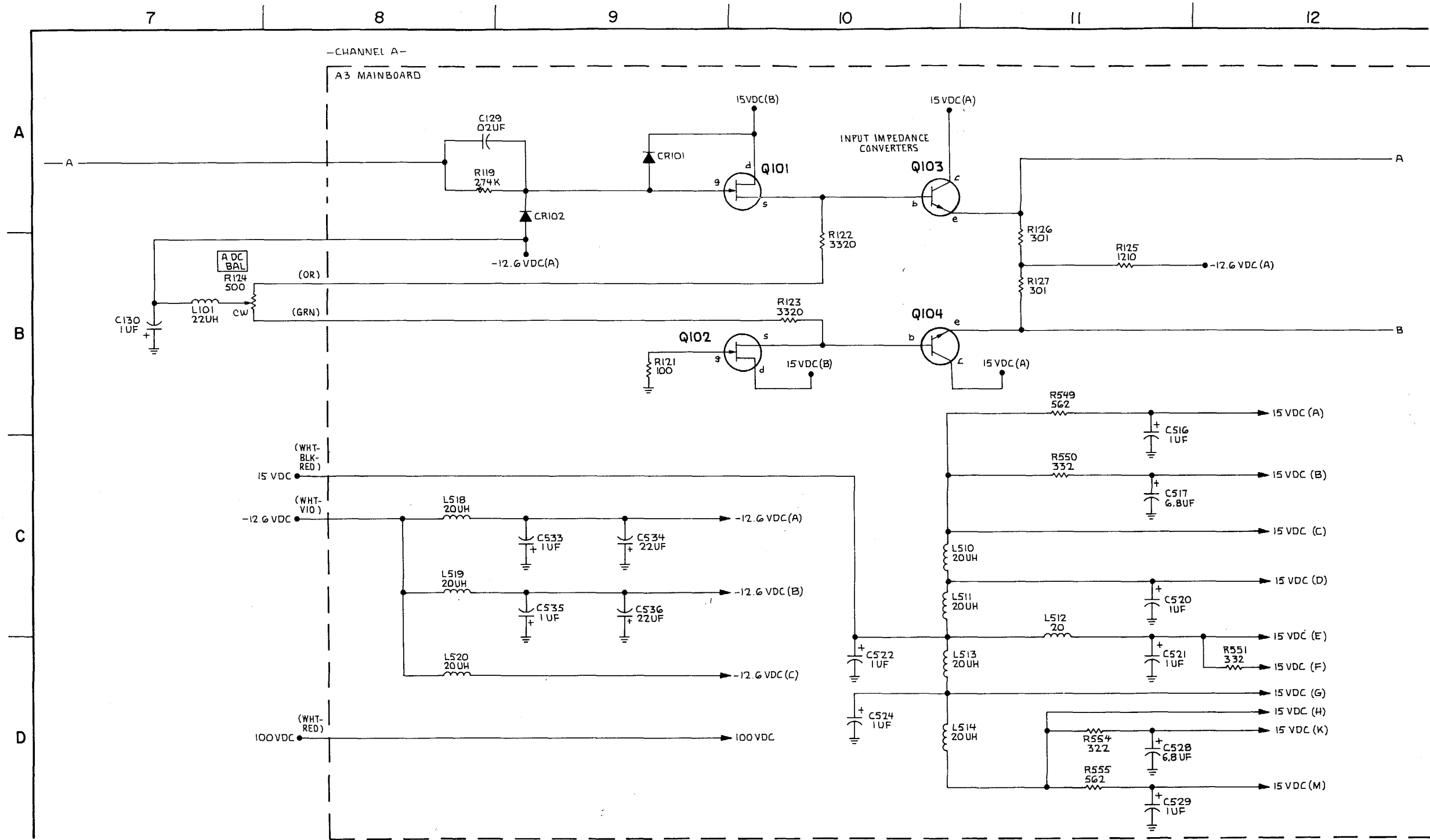

MS 164376

Figure 2-13. Oscilloscope vertical amplifier 10674938 (A61A2) (FG 5100) - schematic (sheet 2 of 14)

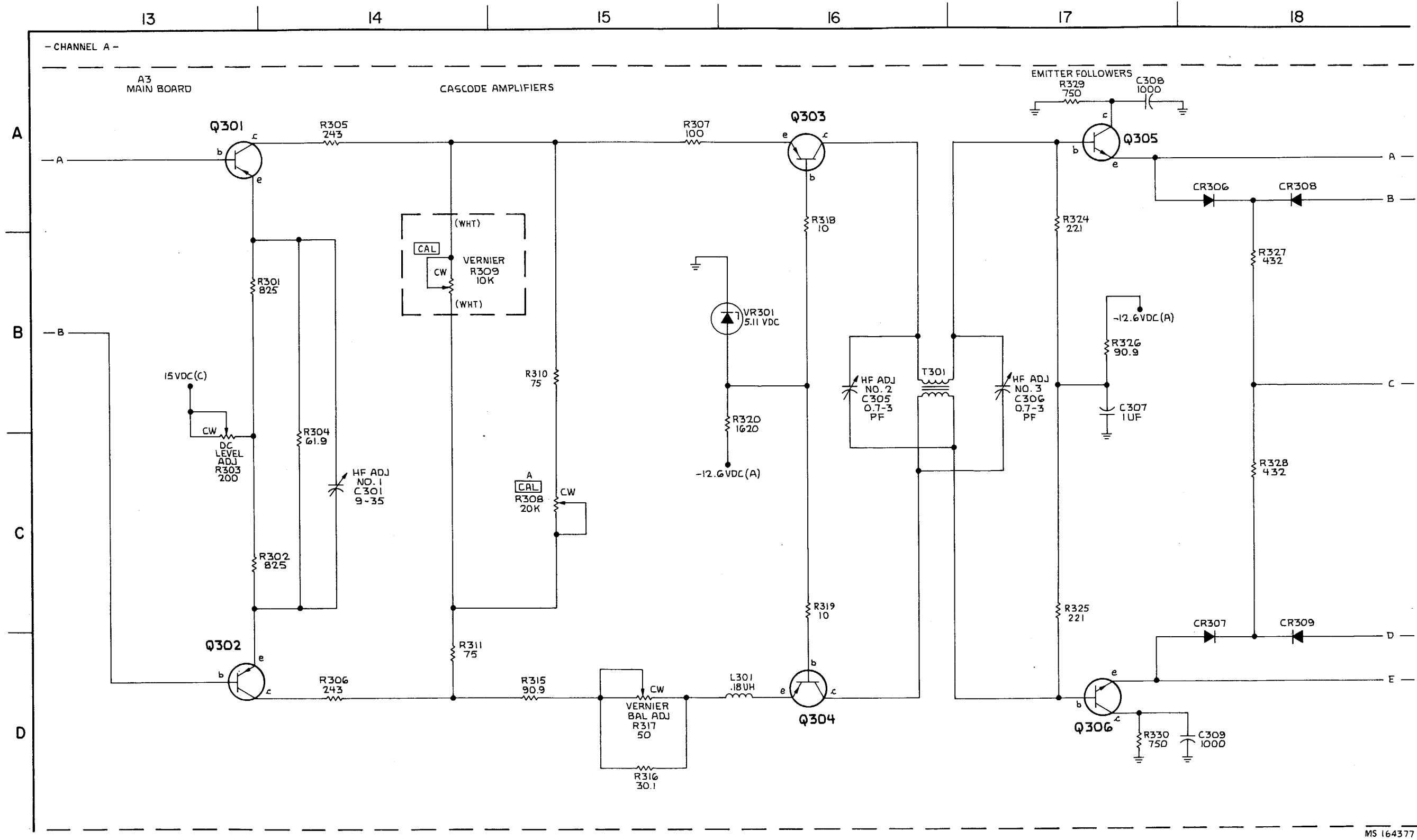
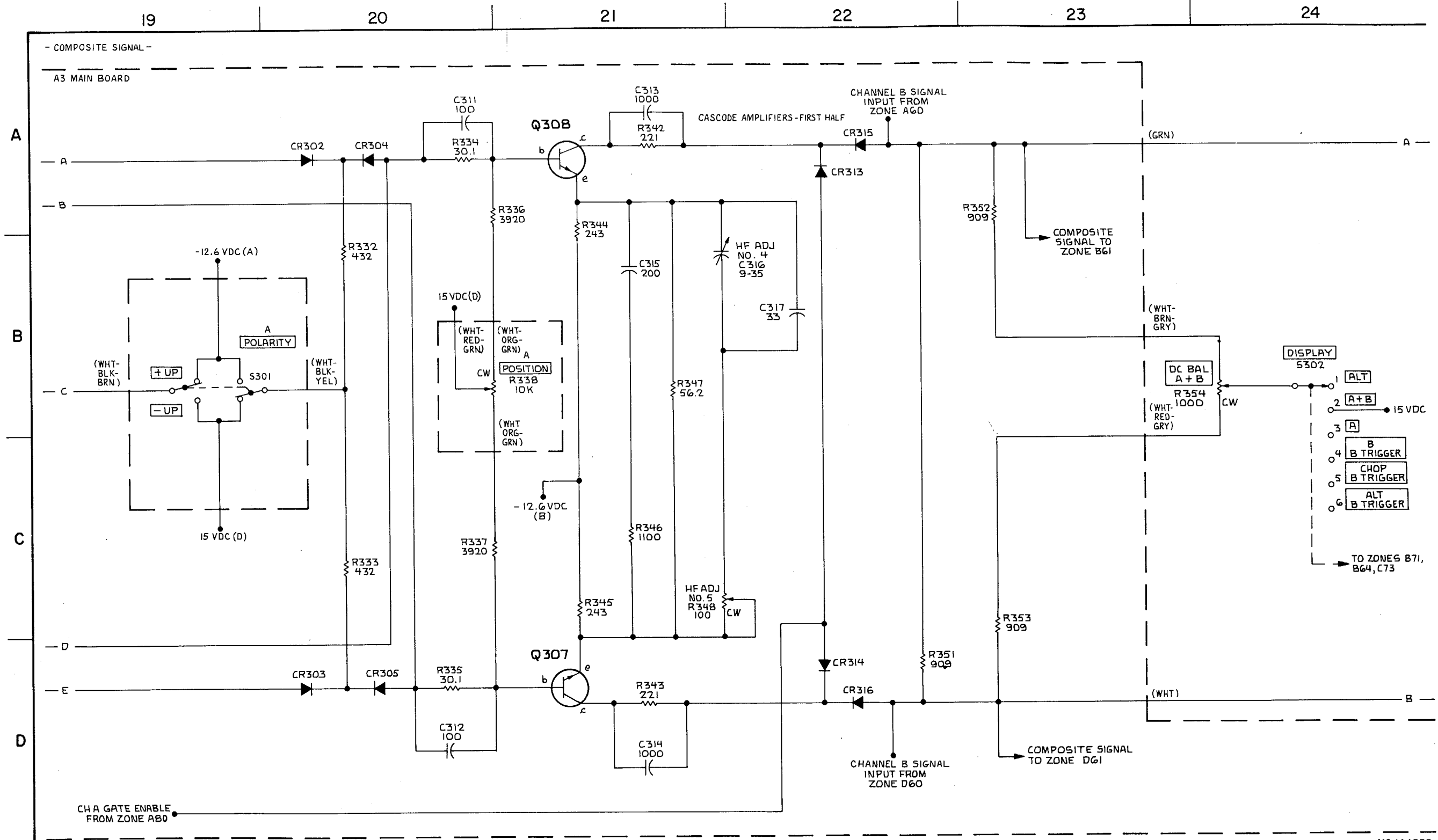

Figure 2-13. Oscilloscope vertical amplifier 10674938 (A61A2) (FG 5100) - schematic (sheet 3 of 14)



MS 164378

Figure 2-13. Oscilloscope vertical amplifier 10674938 (A61A2) (FG 5100) - schematic (sheet 4 of 14)

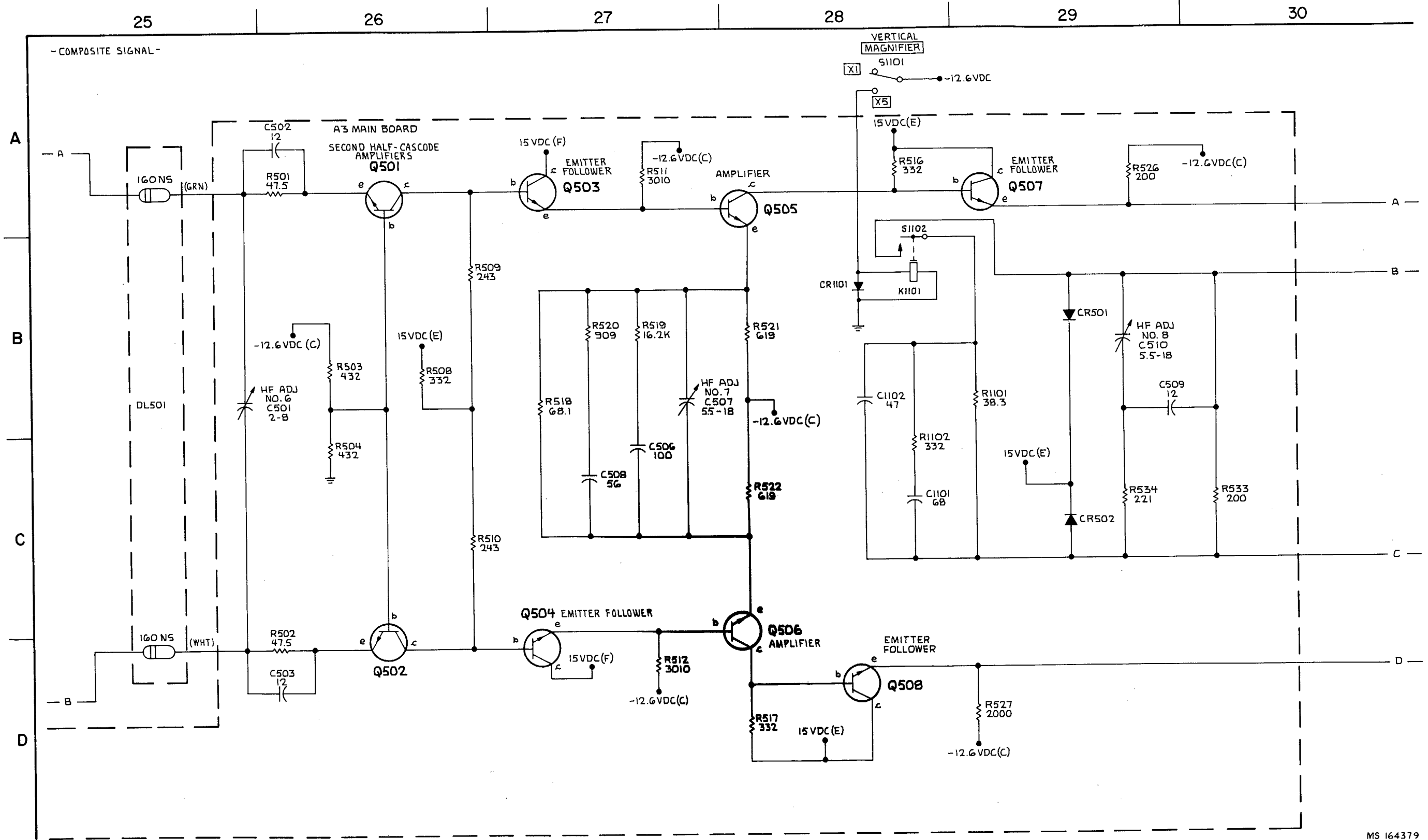

Figure 2-13. Oscilloscope vertical amplifier 10674938 (A61A2) (FG 5100) - schematic (sheet 5 of 14).

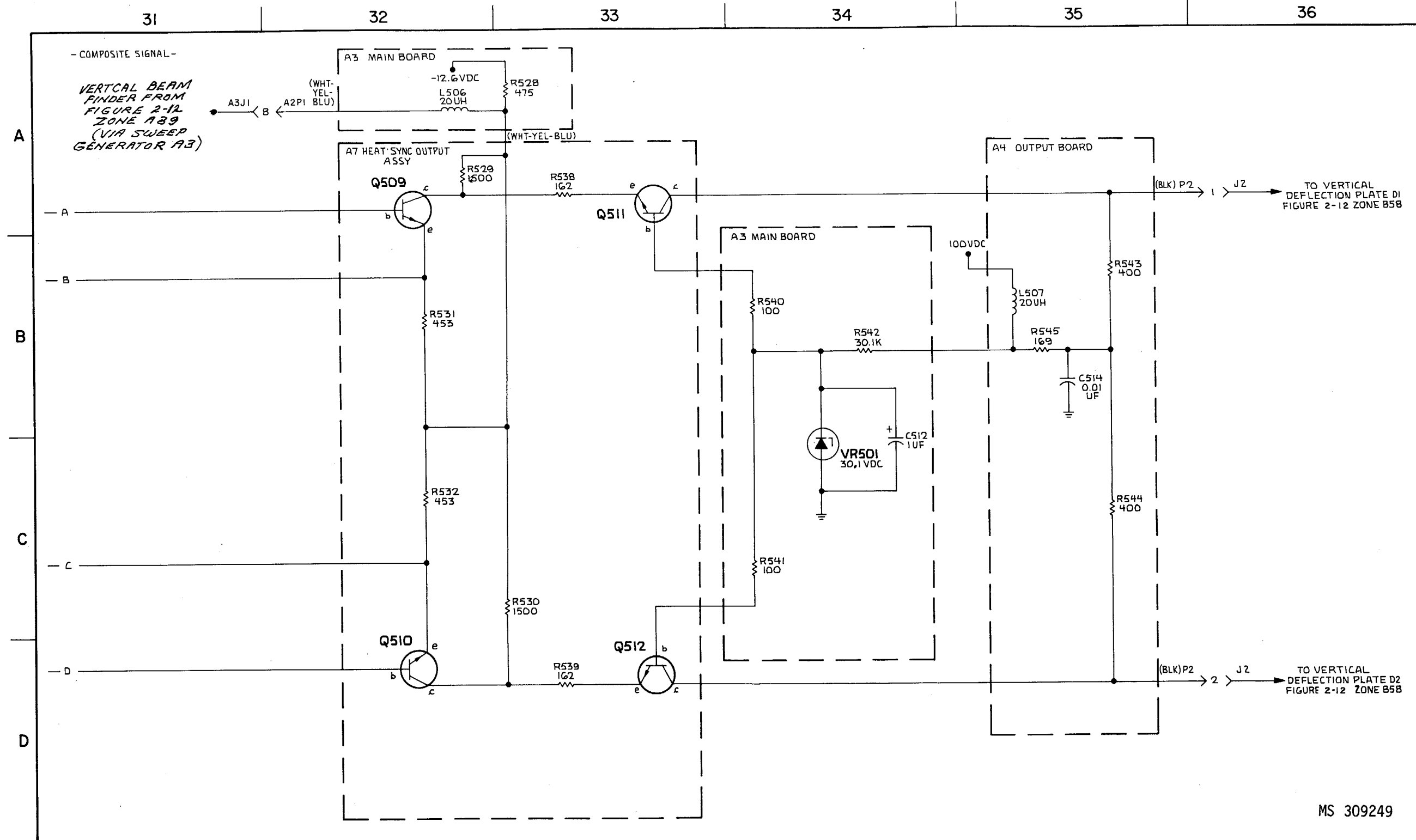
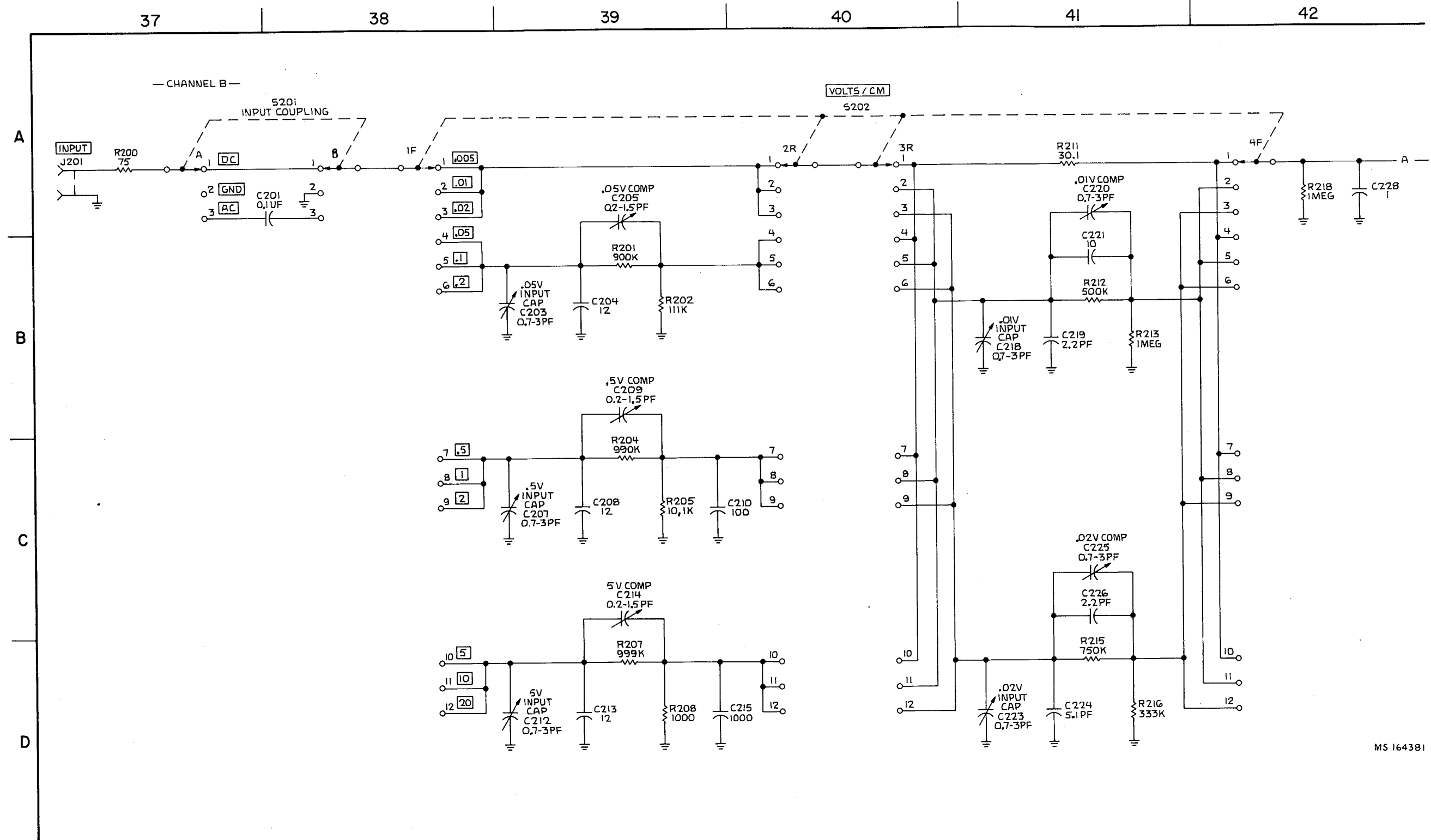
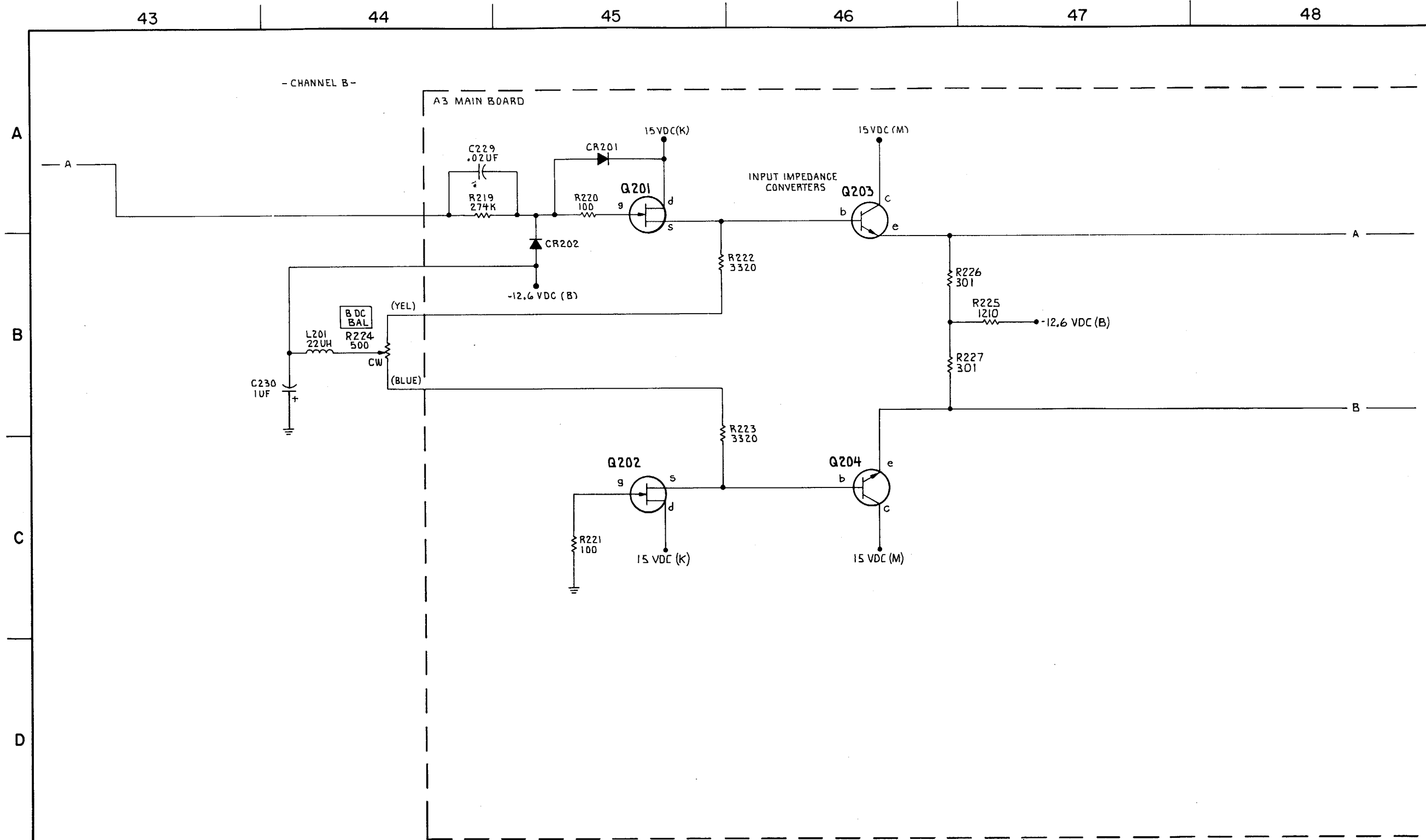

Figure 2-13. Oscilloscope vertical amplifier 10674938 (A61A2) (FG 5100) - schematic (sheet 6 of 14).



MS 164381

Figure 2-13. Oscilloscope vertical amplifier 10674938 (A61A2) (FG 5100) - schematic (sheet 7 of 14).



MS 164382

Figure 2-13. Oscilloscope vertical amplifier 10674938 (A61A2) (FG 5100) - schematic (sheet 8 of 14).

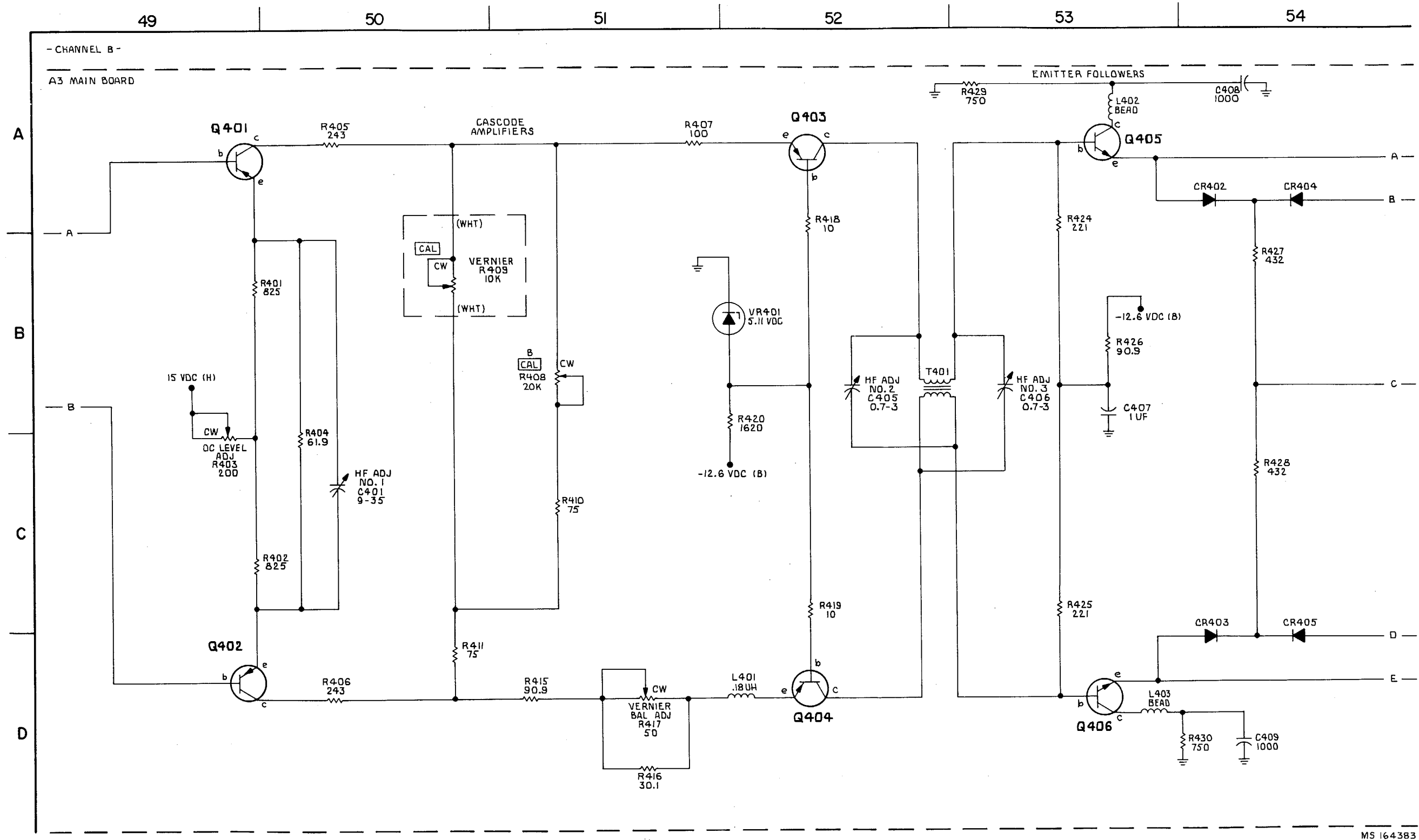

M5 164383

Figure 2-13. Oscilloscope vertical amplifier 10674938 (A61A2) (FG 5100) - schematic (sheet 9 of 14).

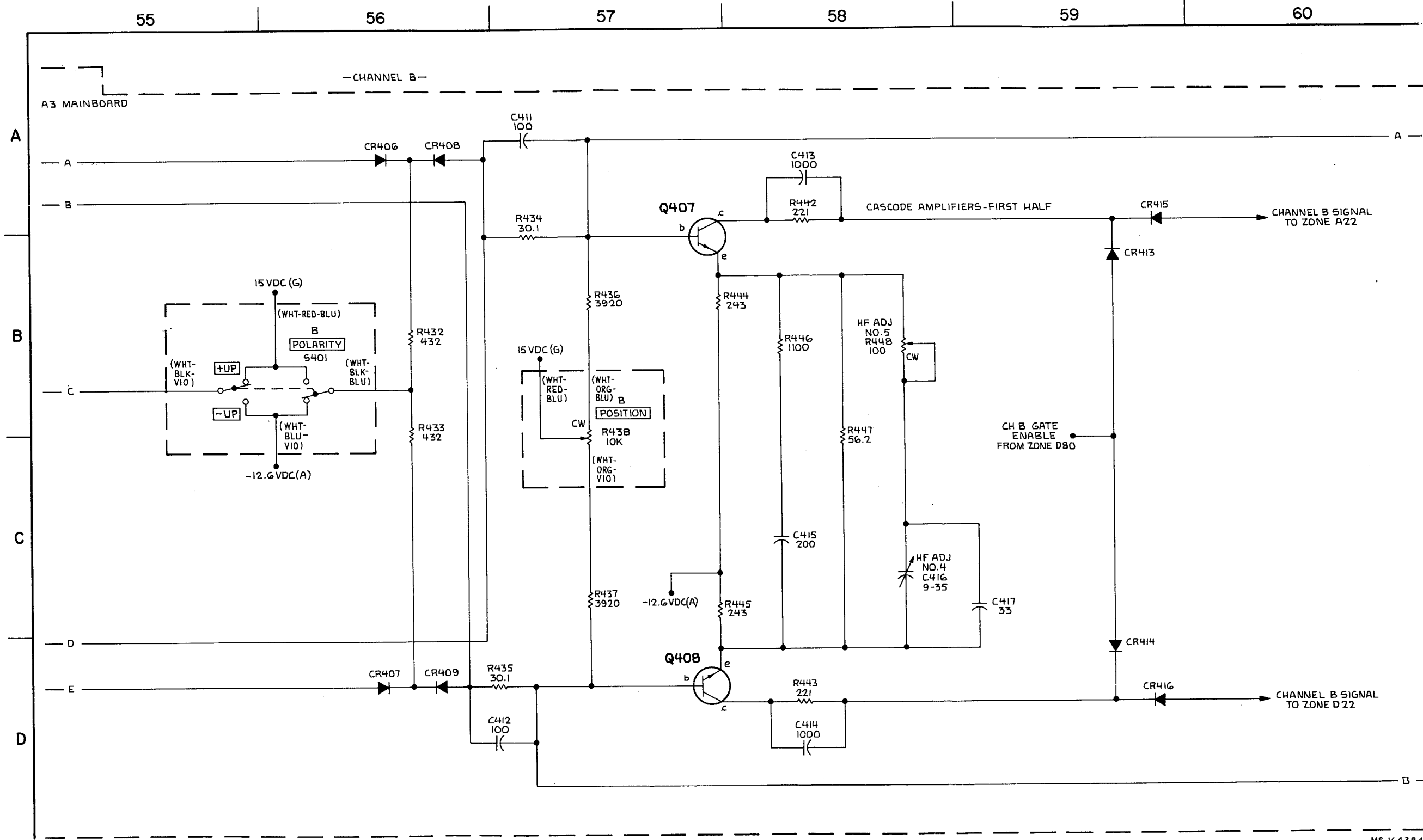

MS 164384

Figure 2-13. Oscilloscope vertical amplifier 10674938 (A61A2) (FG 5100) - schematic (sheet 10 of 14).

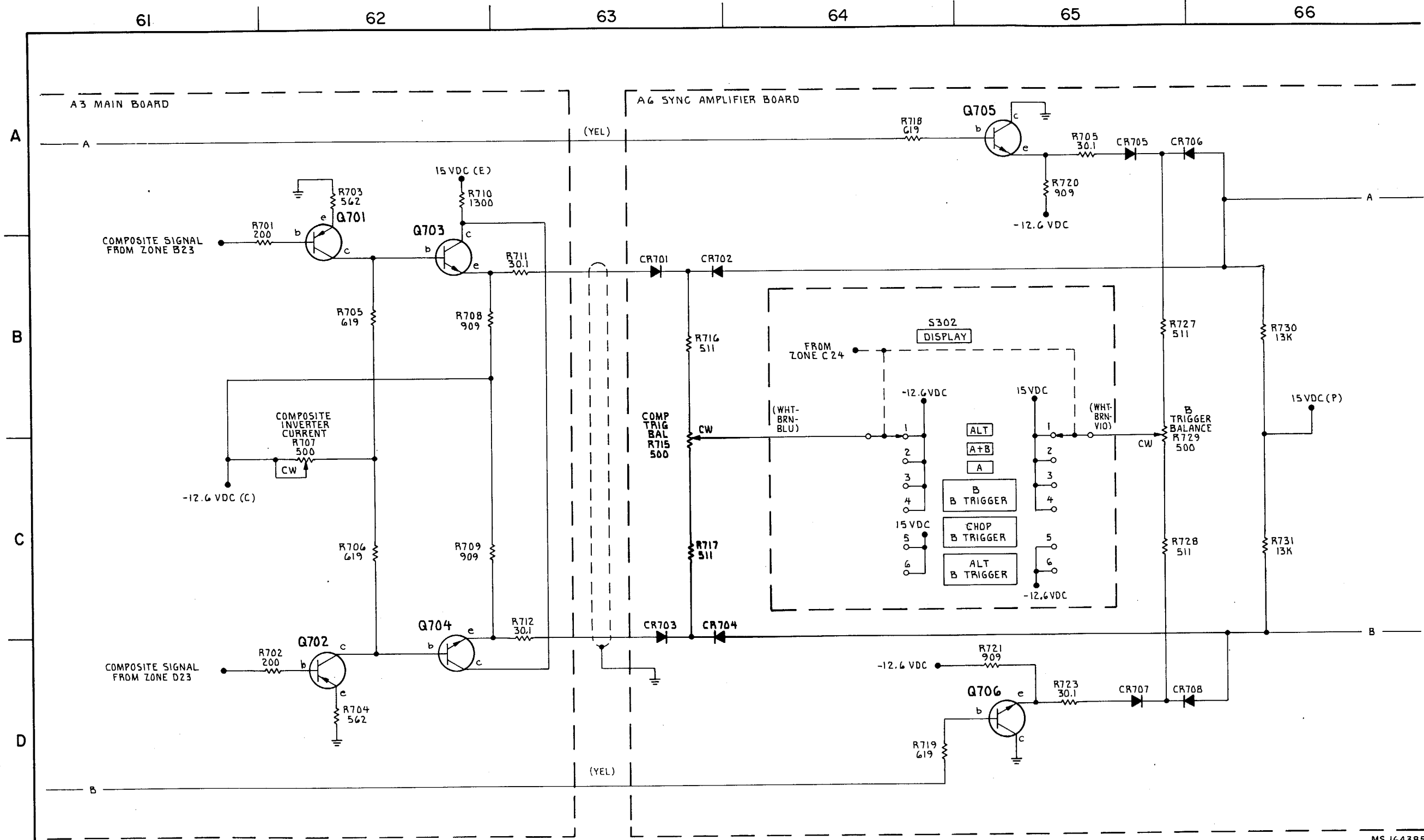

MS 164385

Figure 2-13. Oscilloscope vertical amplifier 10674938 (A61A2) (FG 5100) - schematic (sheet 11 of 14).

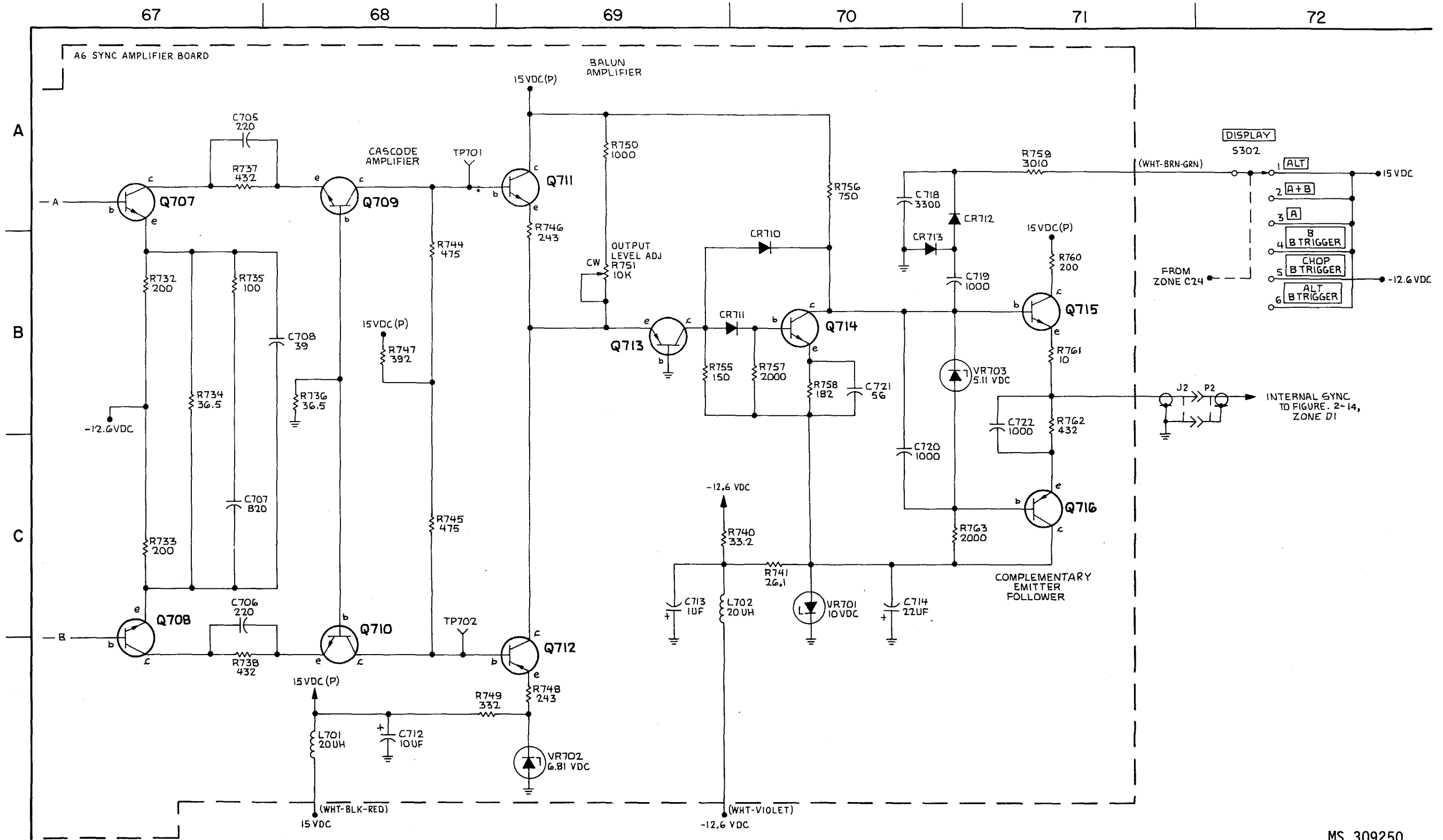

Figure 2-13. Oscilloscope vertical amplifier 10674938 (A61A2) (FG 5100) - schematic (sheet 12 of 14).

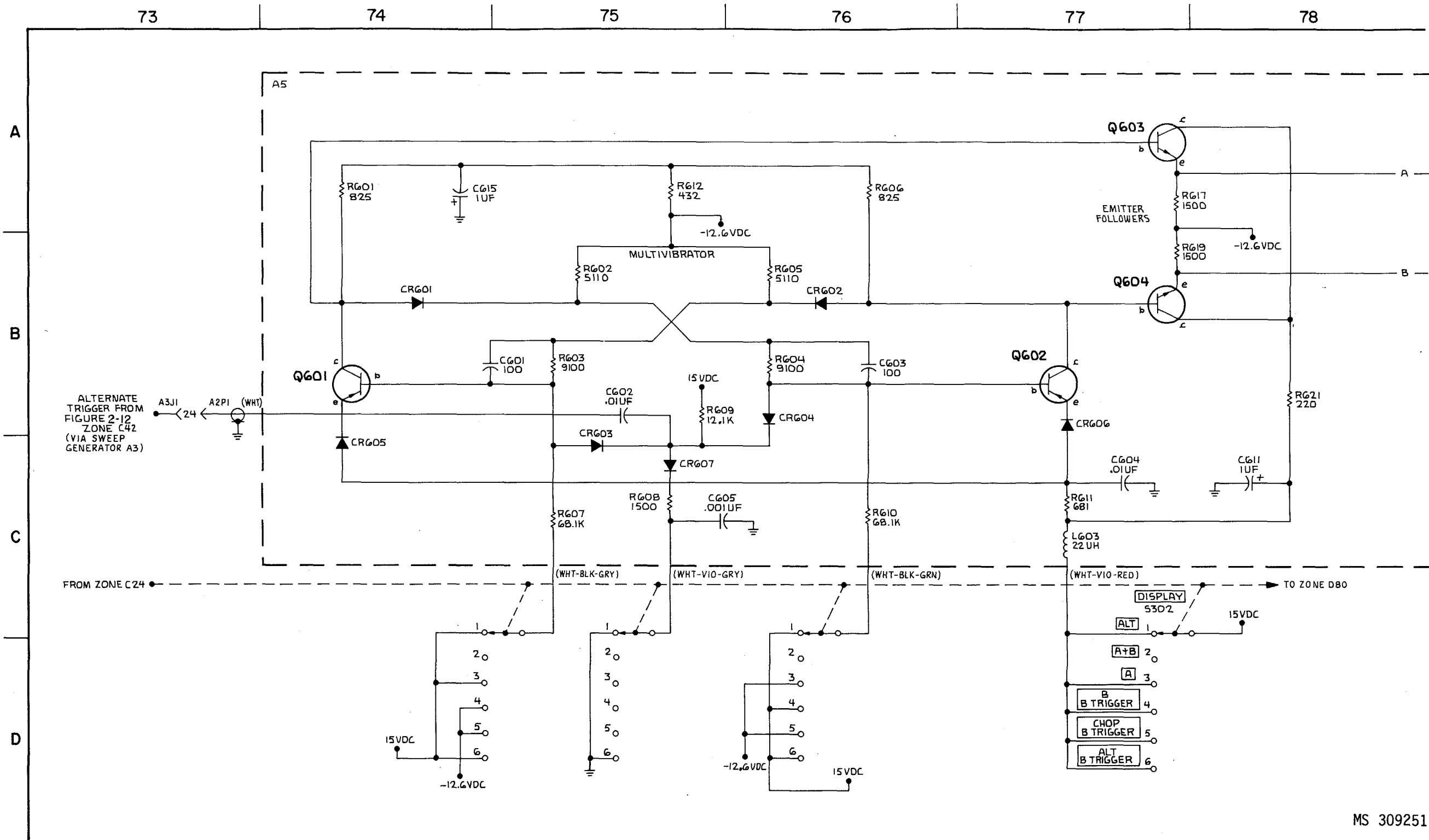
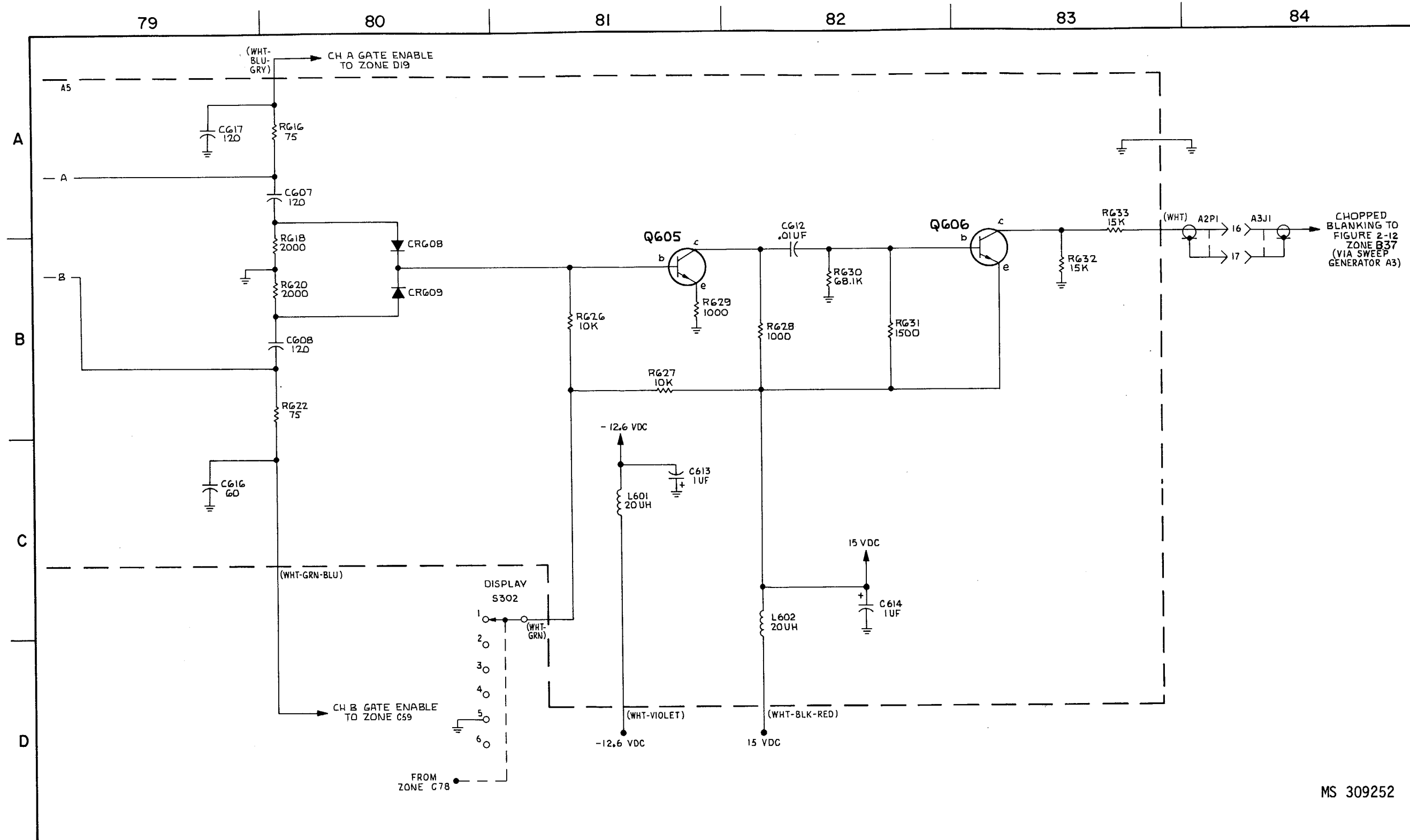

Figure 2-13. Oscilloscope vertical amplifier 10674938 (A61A2) (FG 5100) - schematic (sheet 13 of 14).



MS 309252

Figure -2-13. Oscilloscope vertical amplifier 10674938 (A61A2) (FG 5100)- schematic (sheet 14 of 14).

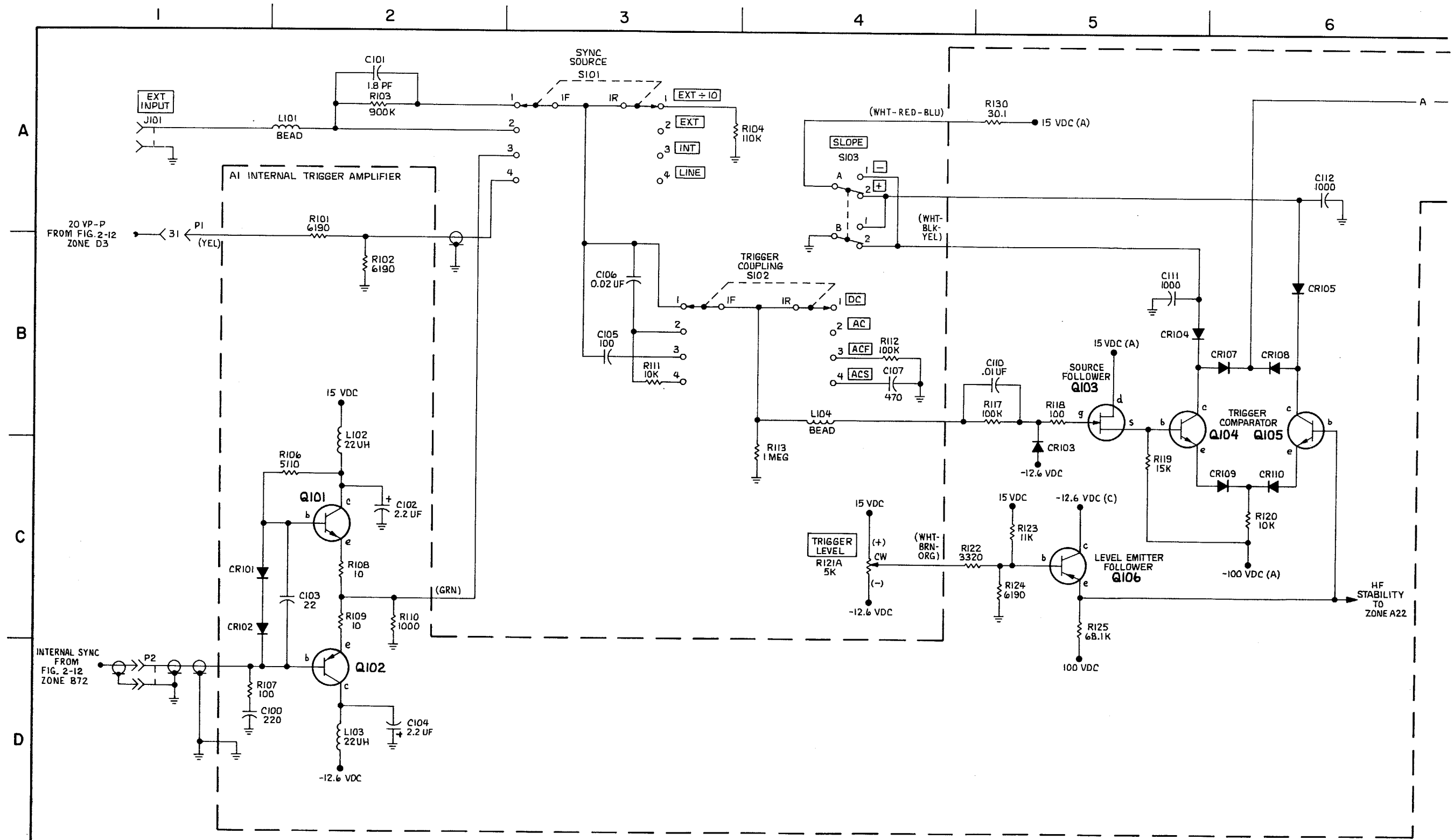

Figure 2-14. Oscilloscope sweep generator 10674939 (A61A63) (FG 5150)- schematic (sheet 1 of 6).

MS 309253

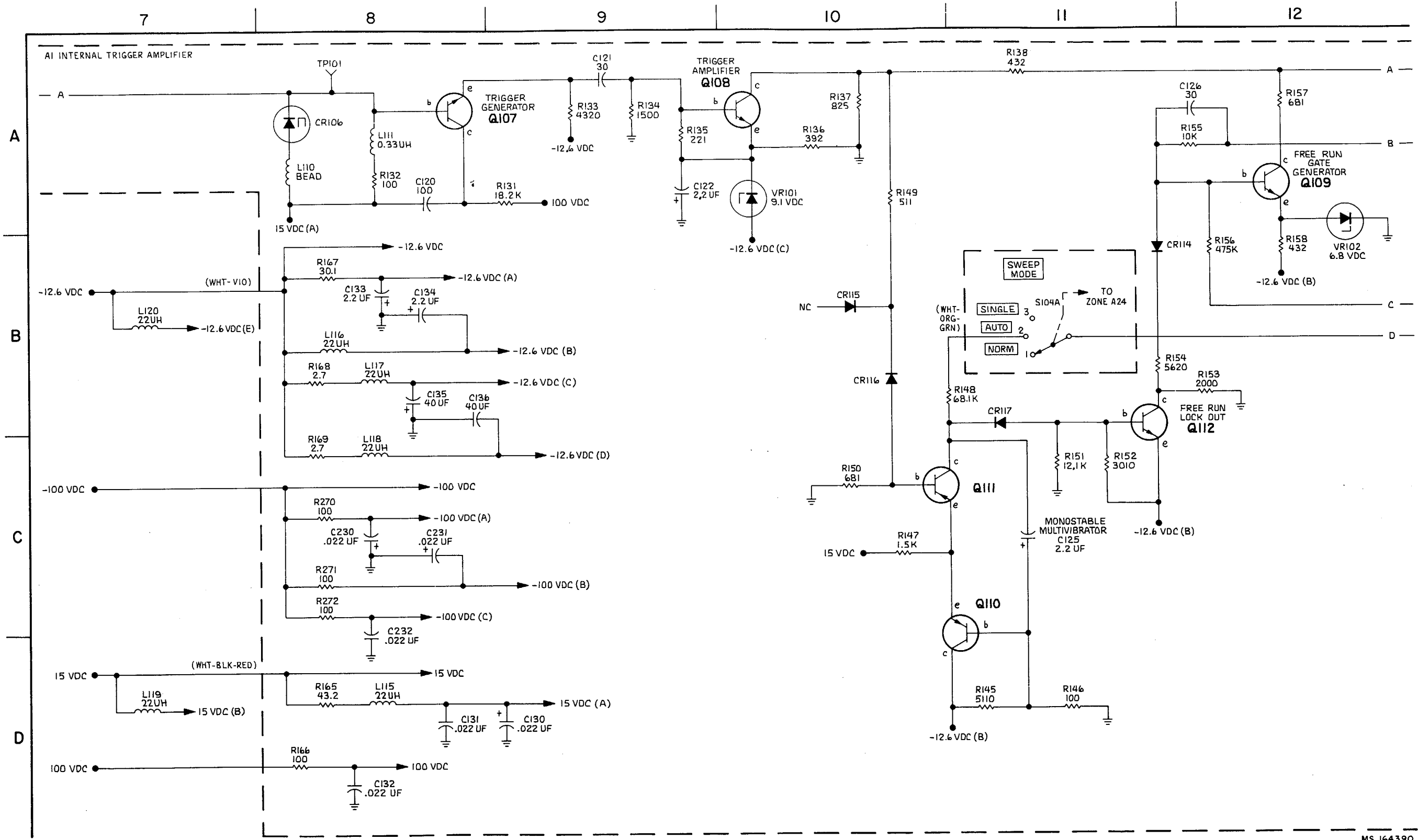

Figure 2-14. Oscilloscope sweep generator 10674939 (A61A63) (FG 5150)- schematic (sheet 2of 6).

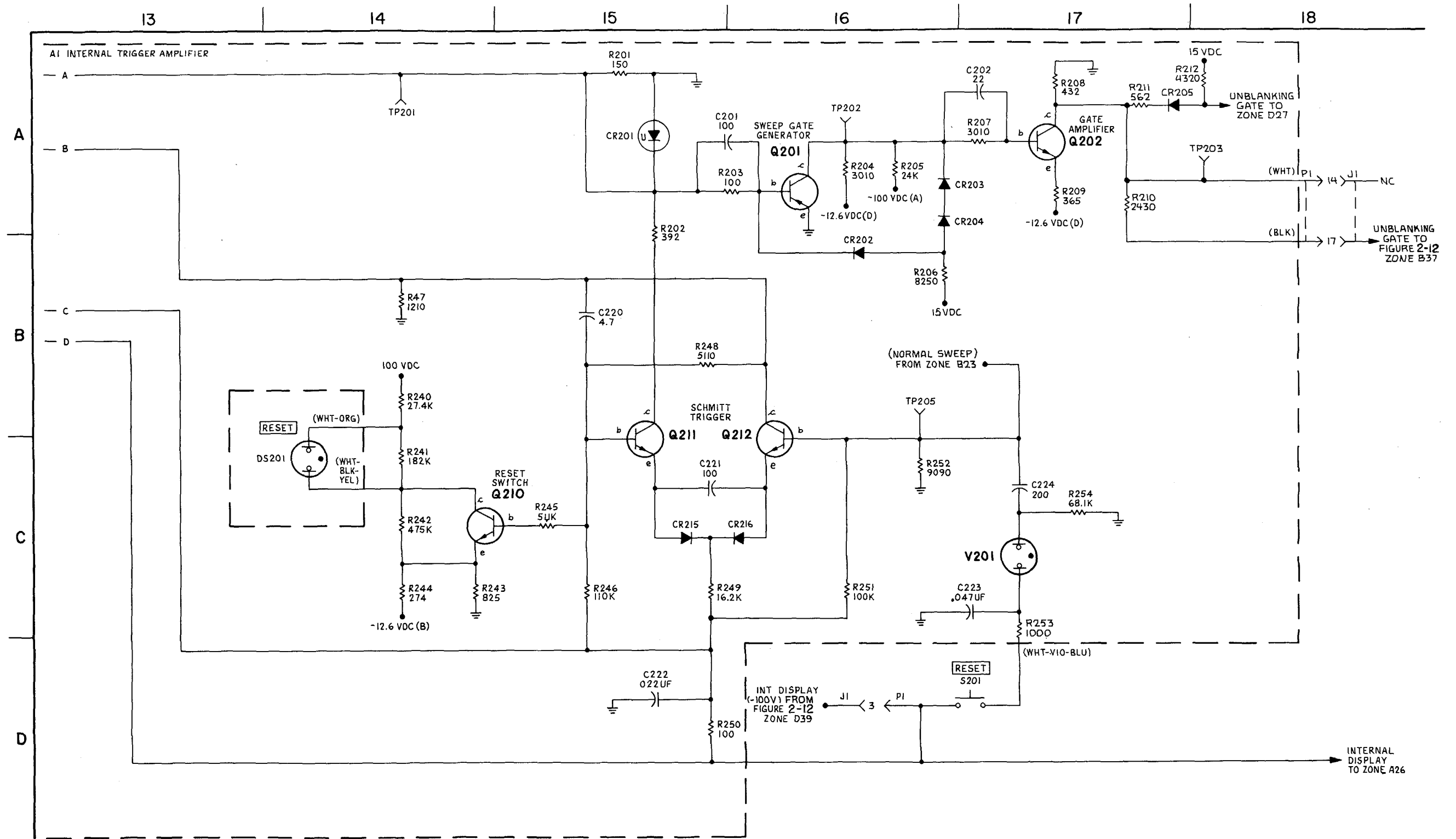
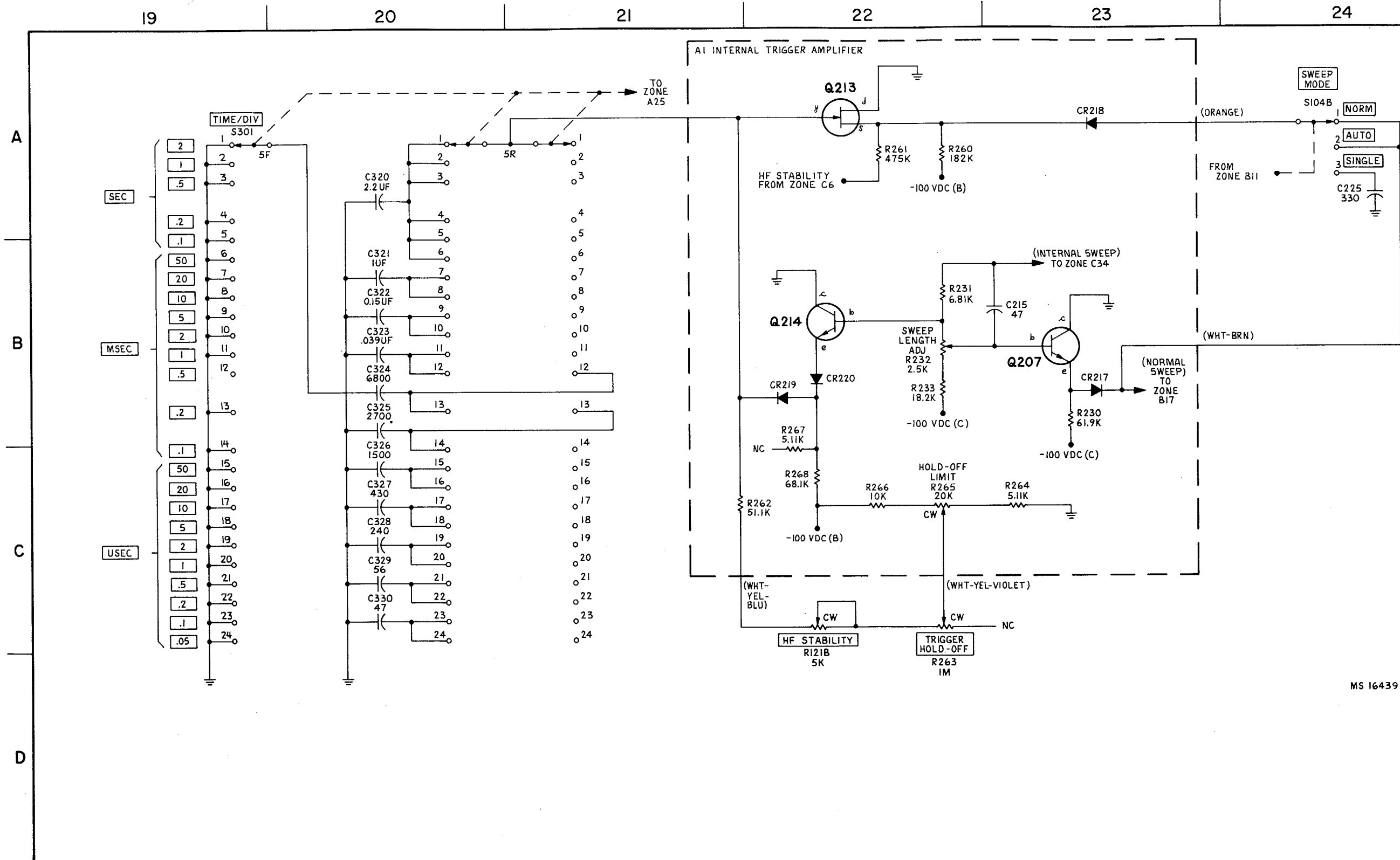

Figure 2-14. Oscilloscope sweep generator 10674939 (A61A63) (FG 5150)- schematic (sheet 3 of 6).

MS 309254



MS 164392

Figure 2-14. Oscilloscope sweep generator 10674939 (A61A63) (FG 5150)- schematic (sheet 4 of 6).

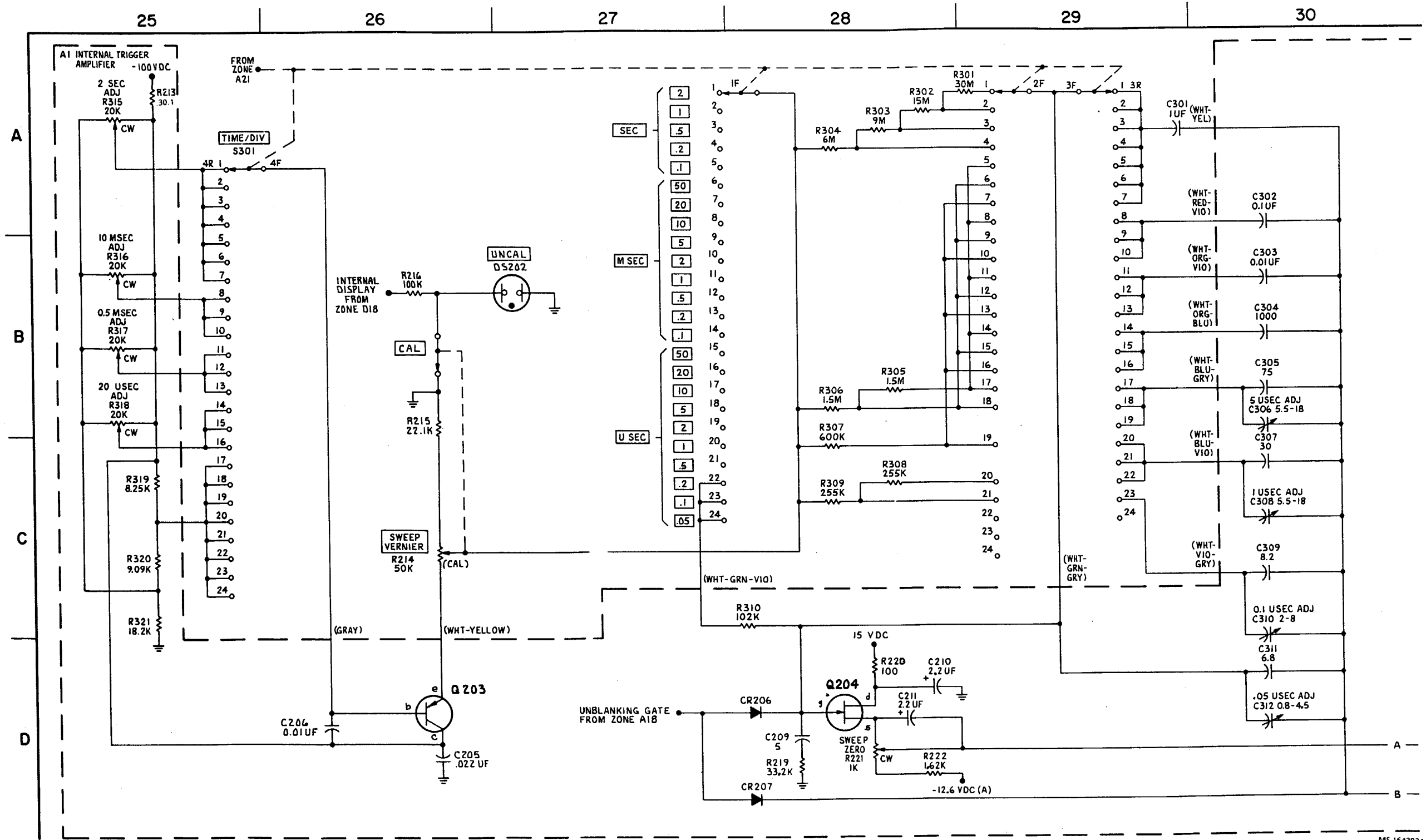

Figure 2-14. Oscilloscope sweep generator 10674939 (A61A63) (FG 5150)- schematic (sheet 5 of 6).

MS 164393A

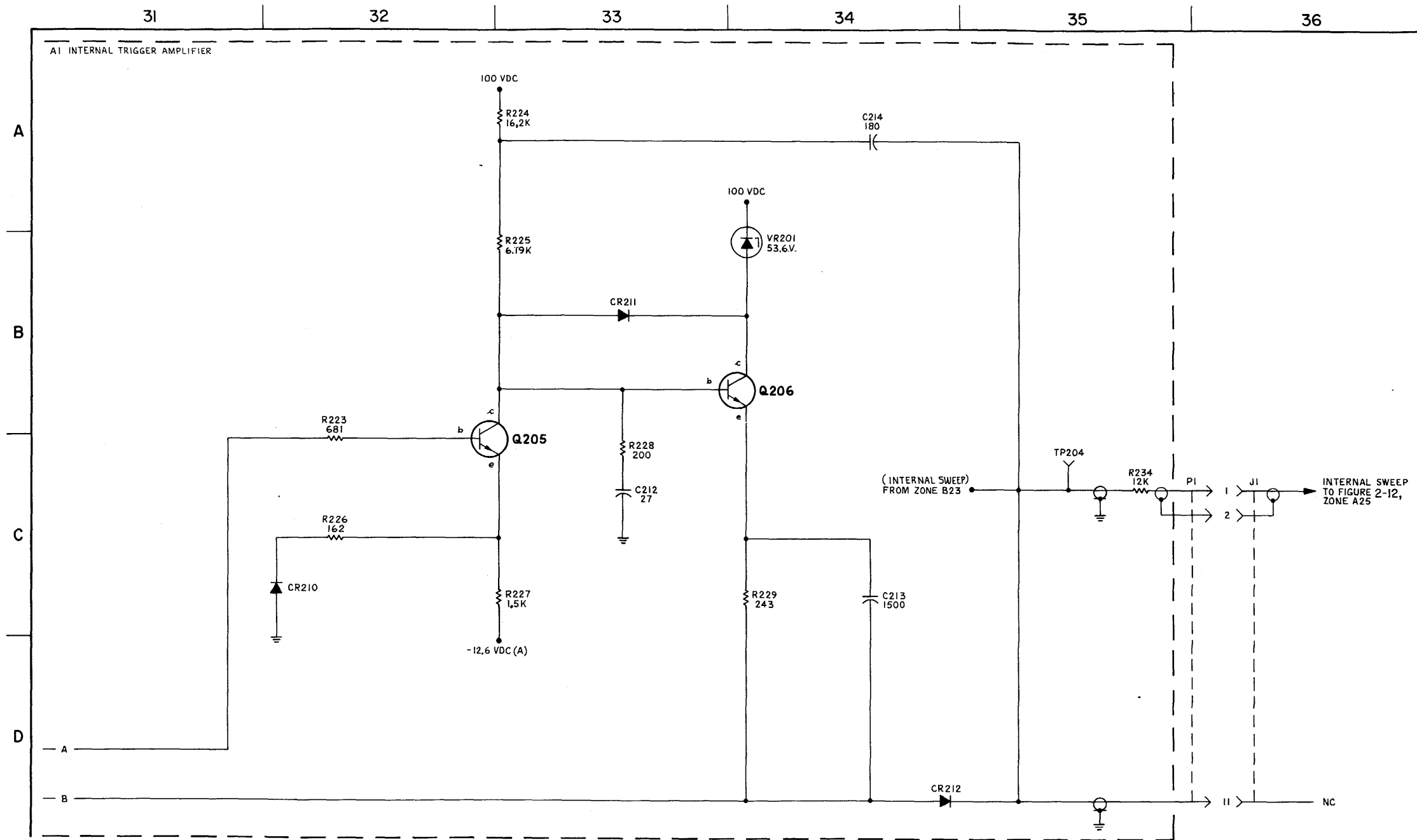

Figure 2-14. Oscilloscope sweep generator 10674939 (A61A63) (FG 5150)- schematic (sheet 6 of 6).

MS 309255

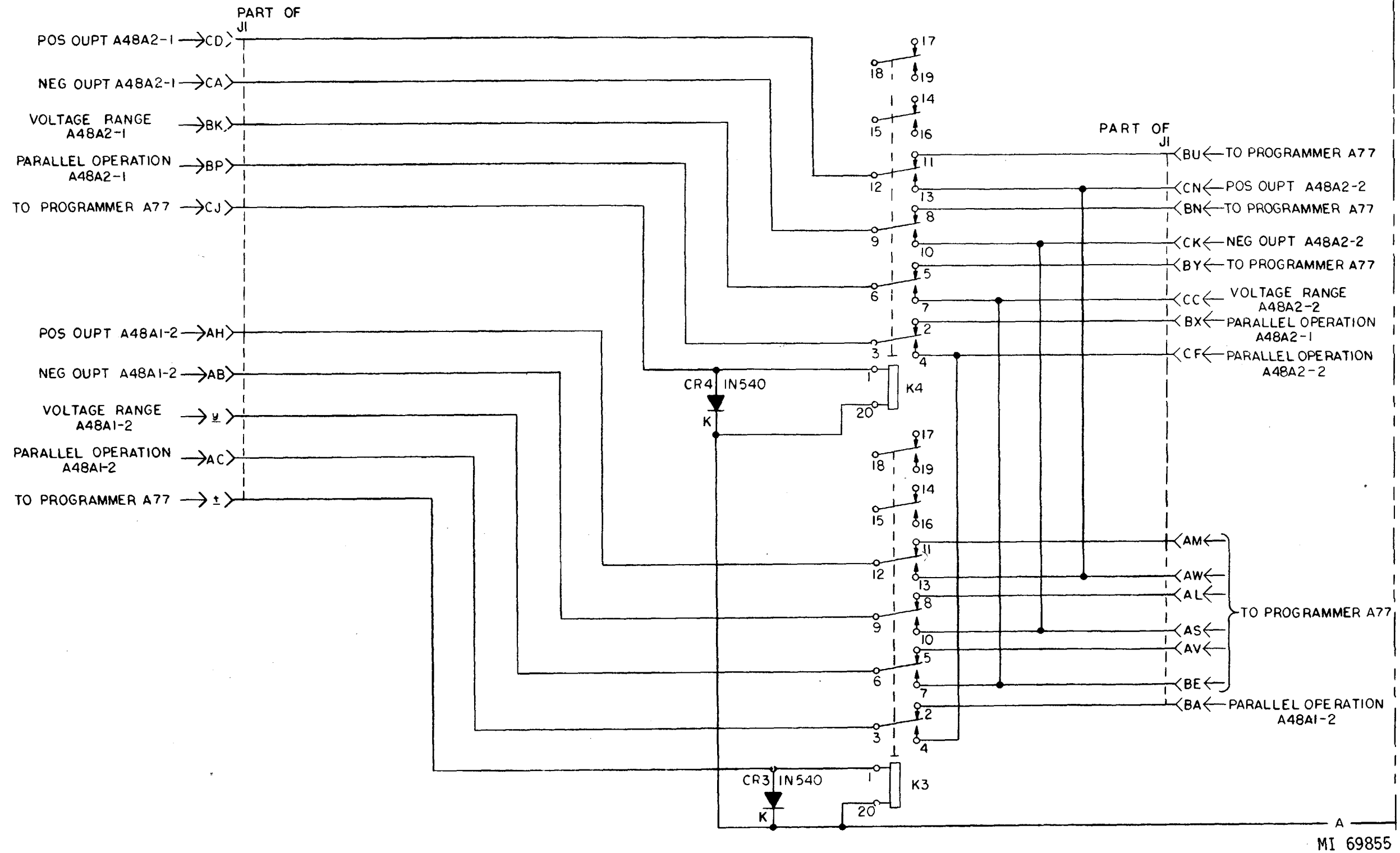

Figure 2-15. Power supply control 10670972 (A59) (FG 7450)- schematic (sheet 1 of 3).

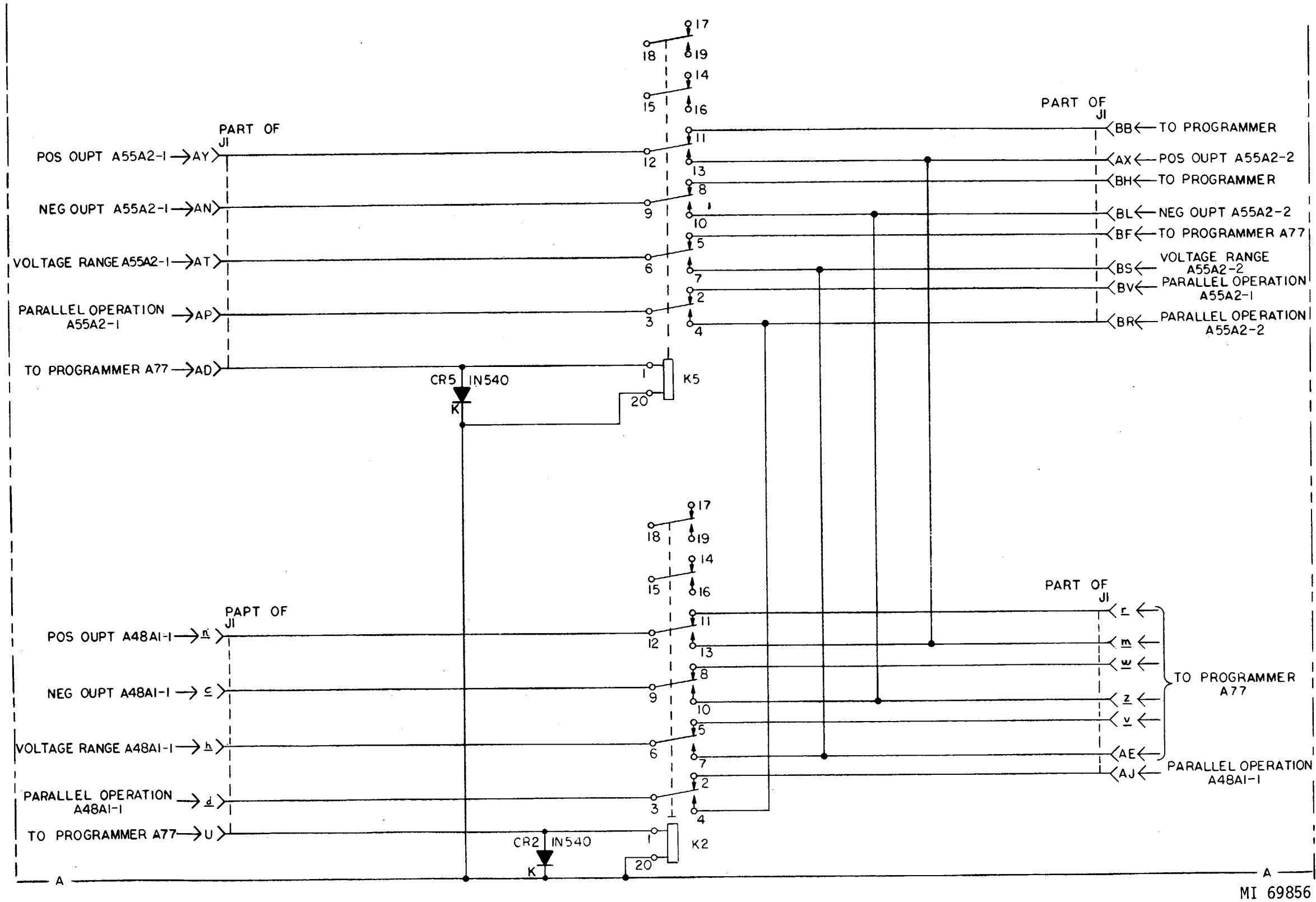

Figure 2-15. Power supply control 10670972 (A59) (FG 7450)- schematic (sheet 2 of 3).

MI 69856

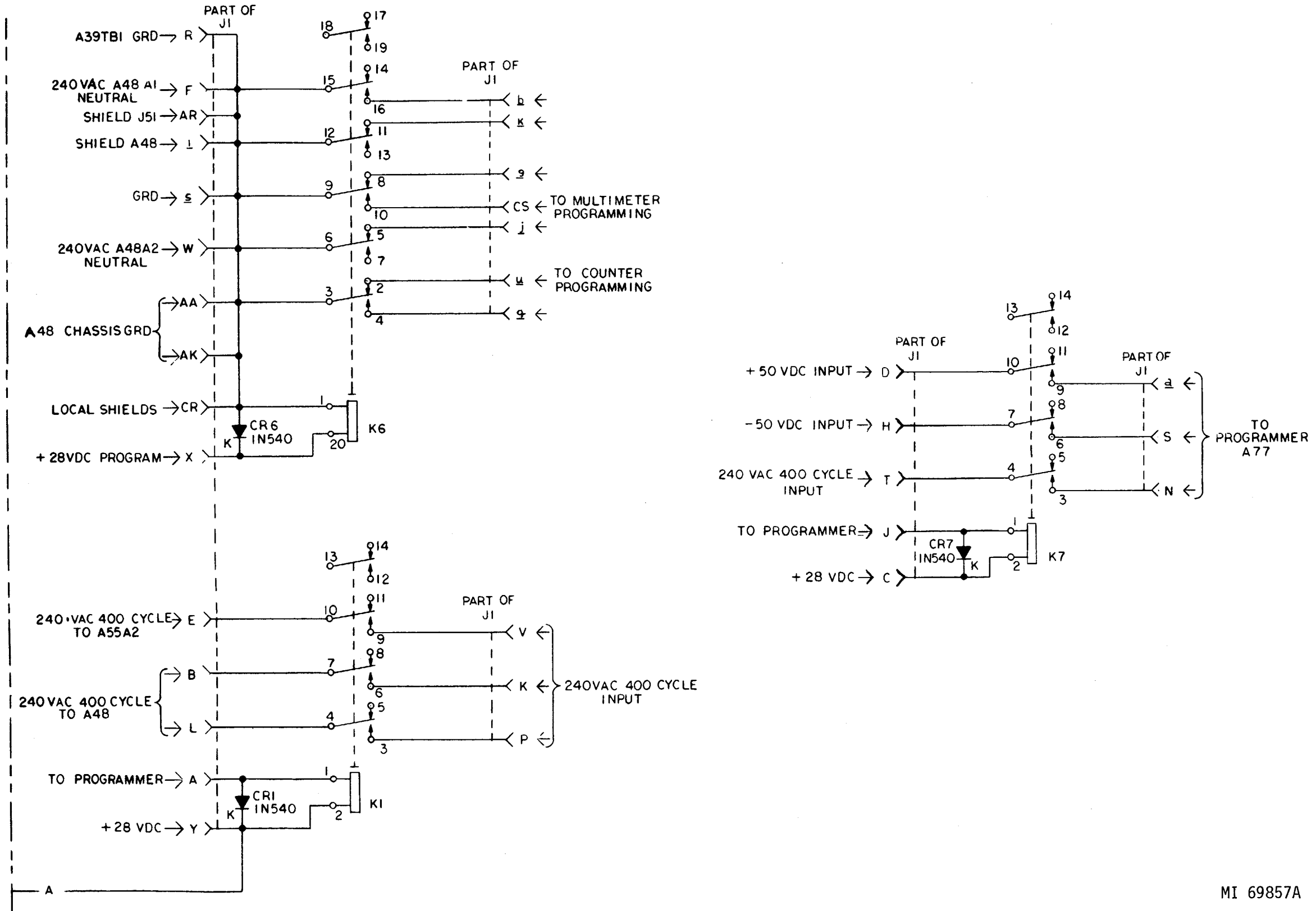
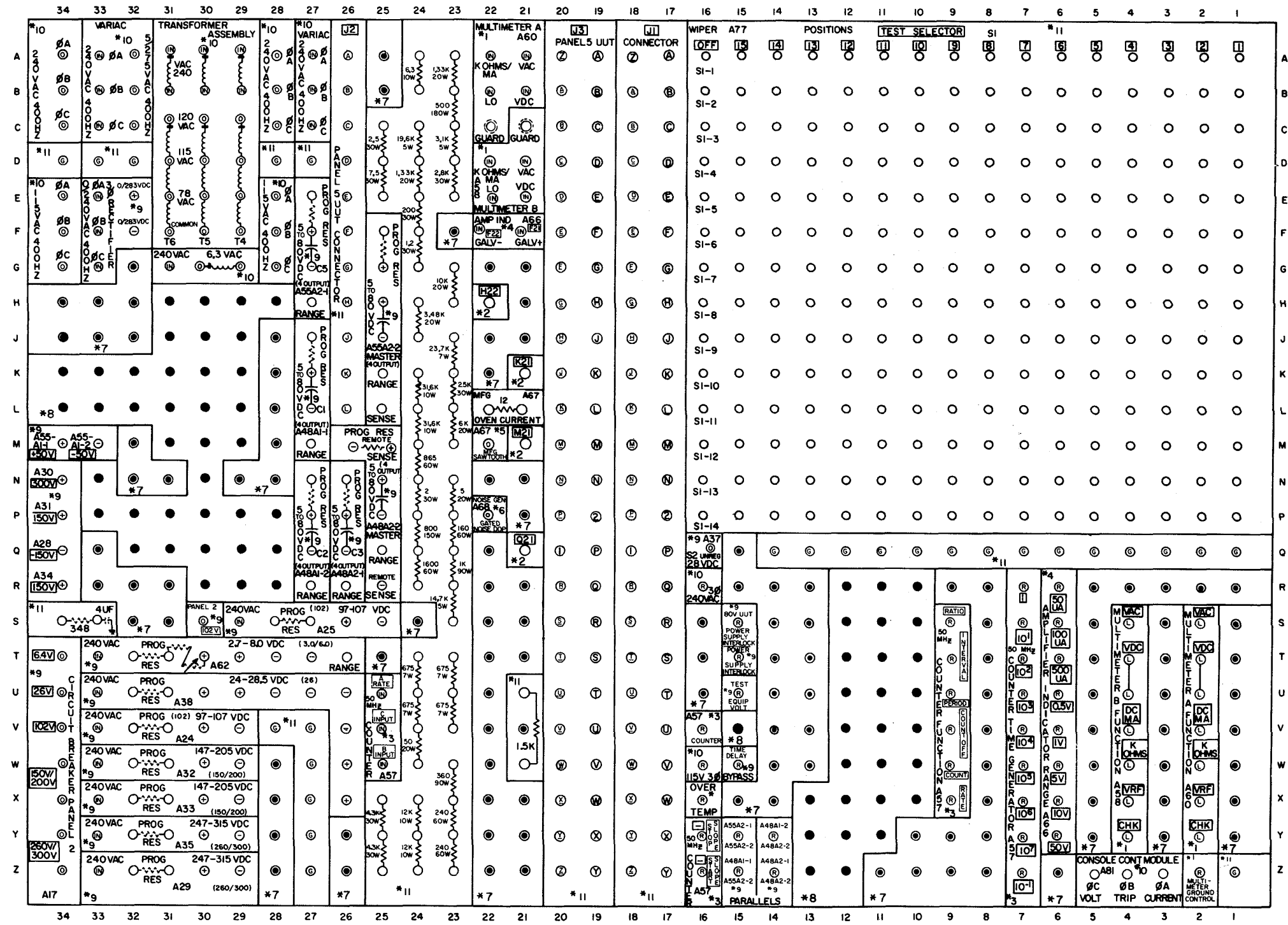

Figure 2-15. Power supply control 10670972 (A59) (FG 7450)- schematic (sheet 3 of 3).



* See notes as indicated on sheet 2.

MS 164596A

Figure 2-16. Master program board -physical/electrical layout (sheet 1 of 2)

NOTE 1. MULTIMETER FUNCTIONS

Z2 to ground floats multimeter LO & GUARDS above ground, and separates LO from GUARDS (AUTO-OVERRIDE to AUTO).
 S2 through Y2 to ground controls the multimeter A MODE.
 S4 through Y4 to ground controls the multimeter B MODE.
 A21 is ac input, A22 is K OHMS/MA input, B21 is dc input, B22 is LO input, C22 is GUARD input for multimeter A.
 D21 is ac input, D22 is K OHMS/MA input, E21 is dc input, E22 is LO input, C21 is GUARD input for multimeter B.

NOTE 2. BNC PANEL CONNECTORS

H22, K21, M21, and Q21 are BNC connectors at PROGRAMMER front panel tied to their respective programmer pins.

NOTE 3. 50-MHZ COUNTER FUNCTIONS

Z16 to ground allows counter START channel to trigger on negative-going signal; Z16 not ground, START triggers on positive-going signal.
 Y16 to ground allows counter STOP channel to trigger on negative-going signal; Y16 not ground, STOP triggers on positive-going signal.
 V16 to ground disconnects V25 and W25 from counter rear inputs (W25 is INPUT B and V25 is INPUT C).
 S9 through X9 to ground controls counter FUNCTION.
 R7 through Z7 to ground controls counter TIME BASE.

NOTE 4. AMPLIFIER-INDICATOR INPUTS

F21 is + GALV input, F22 is - GALV input (also connected to PROGRAMMER front panel F21 and F22 jacks).
 R6 through Y6 to ground controls GALVANOMETER RANGE (AMP-IND "RANGE" to "AUTO").

NOTE 5. MULTI-FUNCTION GENERATOR OUTPUT

M22 is MFG SAWTOOTH output $9 \pm 0.5v$ p-p into 1 megohm impedance.

NOTE 6. THERMAL NOISE GENERATOR OUTPUT

P22 is NOISE GEN output into 600 ohms impedance (0.5 vrms minimum).

NOTE 7. SPARE DEFINITION

⊙ indicates pins are wired to master programmer and may be used for future programming.

NOTE 8. SPARE NON-COMPATIBLE DEFINITION

● indicates pins are wired to master programmer but cannot be used due to compatibility problems.

NOTE 9. POWER SUPPLY FUNCTIONS

Q16 is +28 VDC UNREG output, referenced to ground.
 U15 to ground applies voltages to M34, N34, P34, Q34, R34, and M33.
 T15 to ground applies ac voltages to modules A29, A35, A33, A32, A24, A38, A25, A62 power supply CKT BRKRS CB1-CB8.
 S15 to ground applies ac voltages to A55A2, A48A1, and A48A2.

W15 to ground bypasses console uut power supply time delay.

Y14 to ground parallels 5/80v power supplies A48-A1-2 and A48-A2-2.

Y15 to ground parallels 5/80v power supplies A55-A2-1 and A55-A2-2.

Z14 to ground parallels 5/80v power supplies A48-A2-1 and A48-A2-2.

Z15 to ground parallels 5/80v power supplies A48-A1-1 and A55-A2-2.

S30, T34 through Z34 is 240 vac from circuit breakers on panel A17 (CB1-CB8) (connect to their respective 240 VAC IN pins for power supply operation).

3 ϕ 115 vac to terminals E33 (ϕ A), F33 (ϕ B), and G33 (ϕ C) provides +139 vdc at E32 and -139 vdc at F32 (unfiltered dc).

NOTE 10. THREE-PHASE 240-VAC FUNCTIONS

R16 to ground applies 3 ϕ 240 vac to the following terminals: ϕ A to A28 and A34, ϕ B to B28 and B34, ϕ C to C28 and C34.

Terminals A27 and A33, B27 and B33, C27 and C33 are the ϕ A, ϕ B, and ϕ C inputs, respectively, of the 3 ϕ VARIAC.

Terminals A32, B32, and C32 are the ϕ A, ϕ B, and ϕ C outputs, respectively, of the 3 ϕ VARIAC.

W16 to ground applies 3 ϕ 115 vac to the following terminals: ϕ A to E28 and E34, ϕ B to F28 and F34, ϕ C to G28 and G34.

T4, T5, T6 are isolation transformers (applying a voltage at terminals A or B 29, 30, or 31 results in an output voltage at terminals C, D, E, or F 29, 30, or 31 and ground).

G30, G29 is 6.3 vac transformer (3A) output (needs 240 vac input at G31 from T34).

Z3, Z4, Z5 are ϕ A, ϕ B, and ϕ C console control module current programming pins (ground for 10 amp operation, 200 ohms to ground is approximately 7.5 amps).

NOTE 11. GENERAL INFORMATION

S34, S33 is filter network referenced to console ground.

J1 (A17 through Z18) is uut connector at panel 5, A20.

J2 (A26 through L26) is uut connector at panel 5, A20.

J3 (A19 through Z20) is uut connector at panel 5, A20.

U21 to W21 is a 20-watt, 1.5K resistor; all other resistances are as indicated at pins in rows 23, 24, and 25. Wattage ratings shown are the "effective" operating wattages of the resistors. Refer to the appropriate apparatus list for the actual wattage ratings.

Q1 through Q14 and Z1 are used for relay and logic grounds.

D32, D33, D27 are grounds but not to be used for signal or power supply grounds.

V28, V27, Z27, D34, and D28 are used for power supply and signal grounds.

SYMBOL DEFINITION

⊙	Logic
●	Relay
○	Ground
IN	Input
O	Output
+	Positive
-	Negative
○	Terminal

MS 164597B

Figure 2-16. Master program board-physical/electrical layout (sheet 2 of 2).

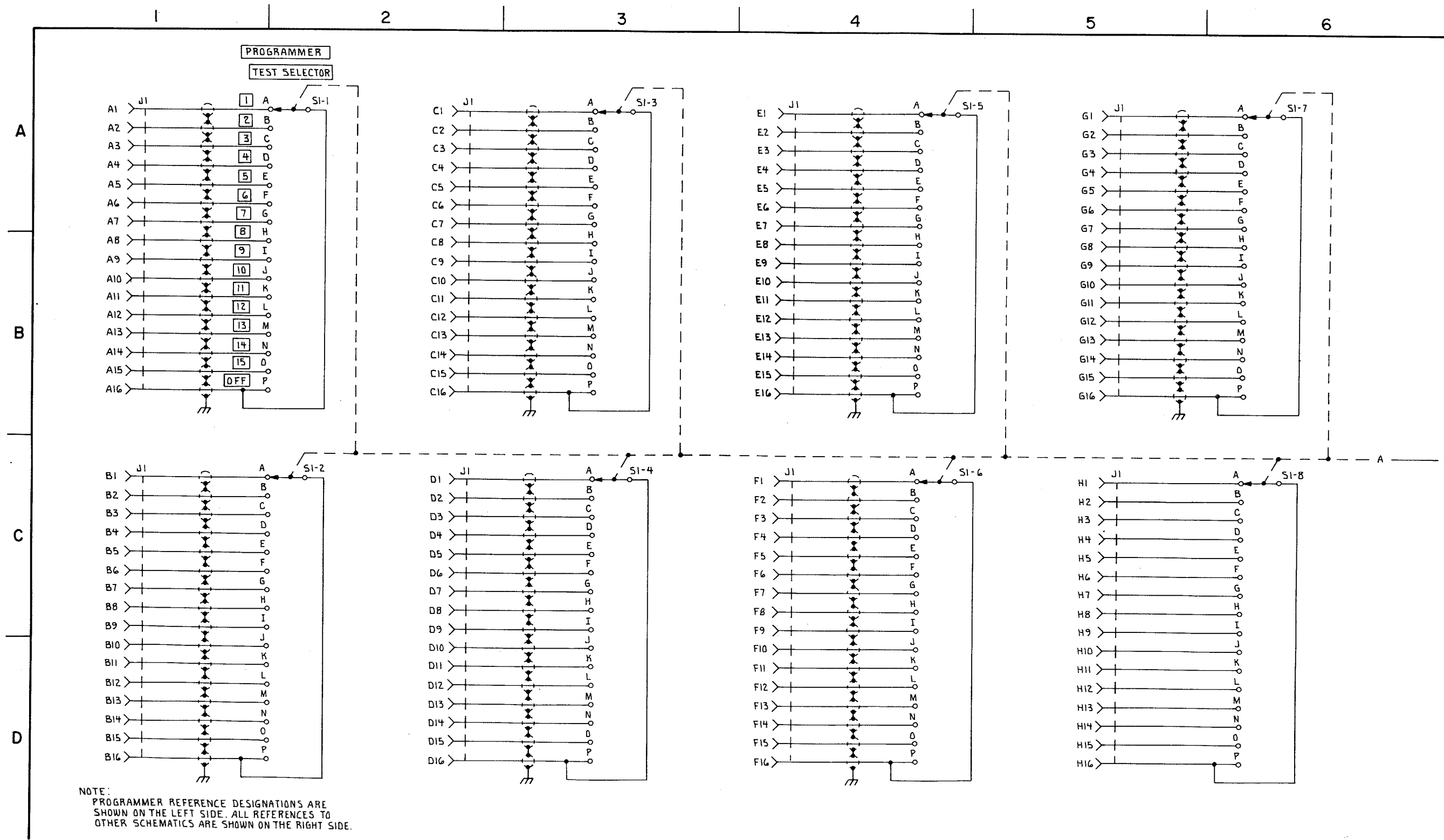

MS164598A

Figure 2-17. Programmer 10670685 (A77) (FG 6450) -schematic (sheet 1 of 10)

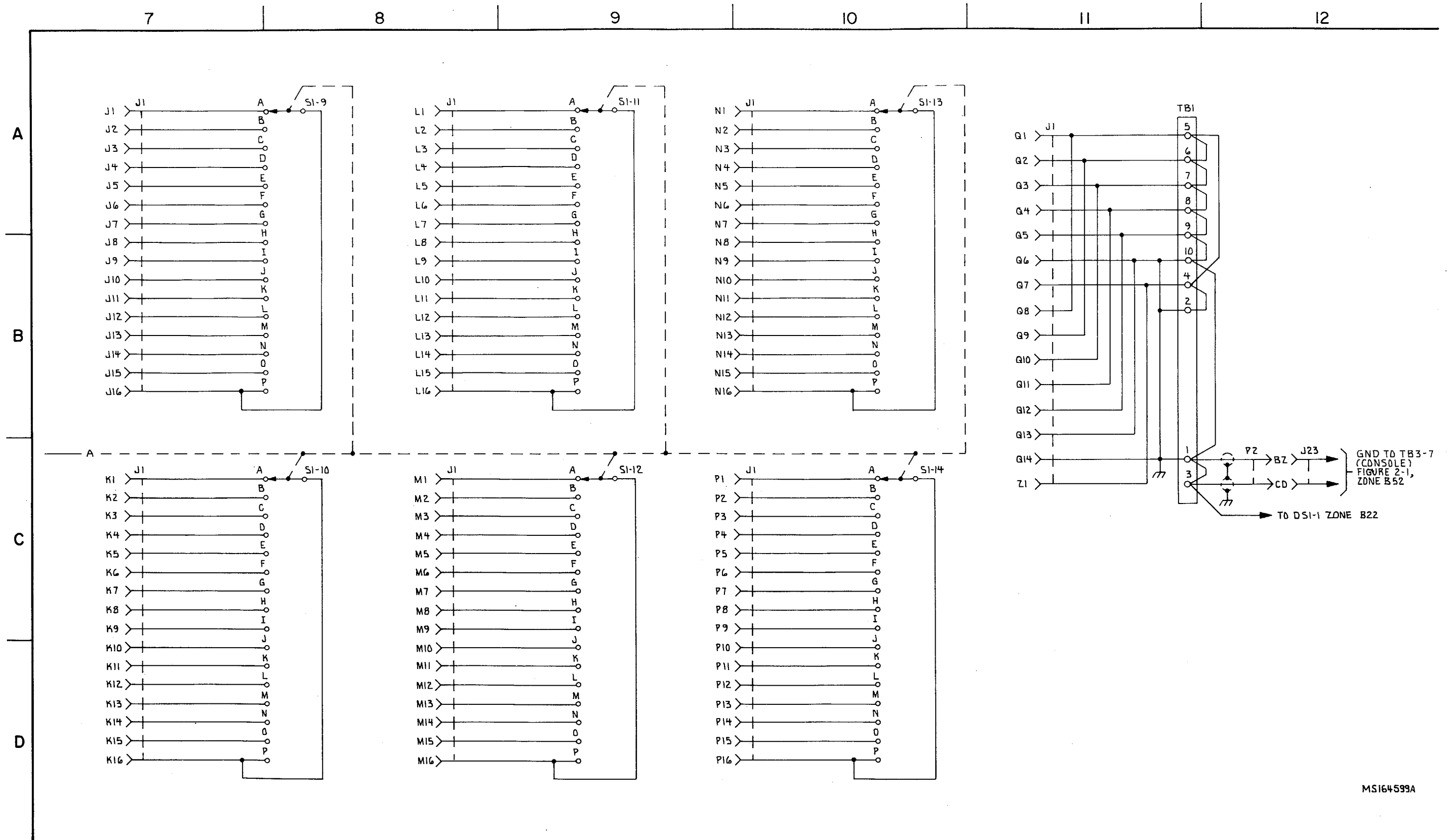

Figure 2-17. Programmer 10670685 (A77) (FG 6450) -schematic (sheet 2 of 10)

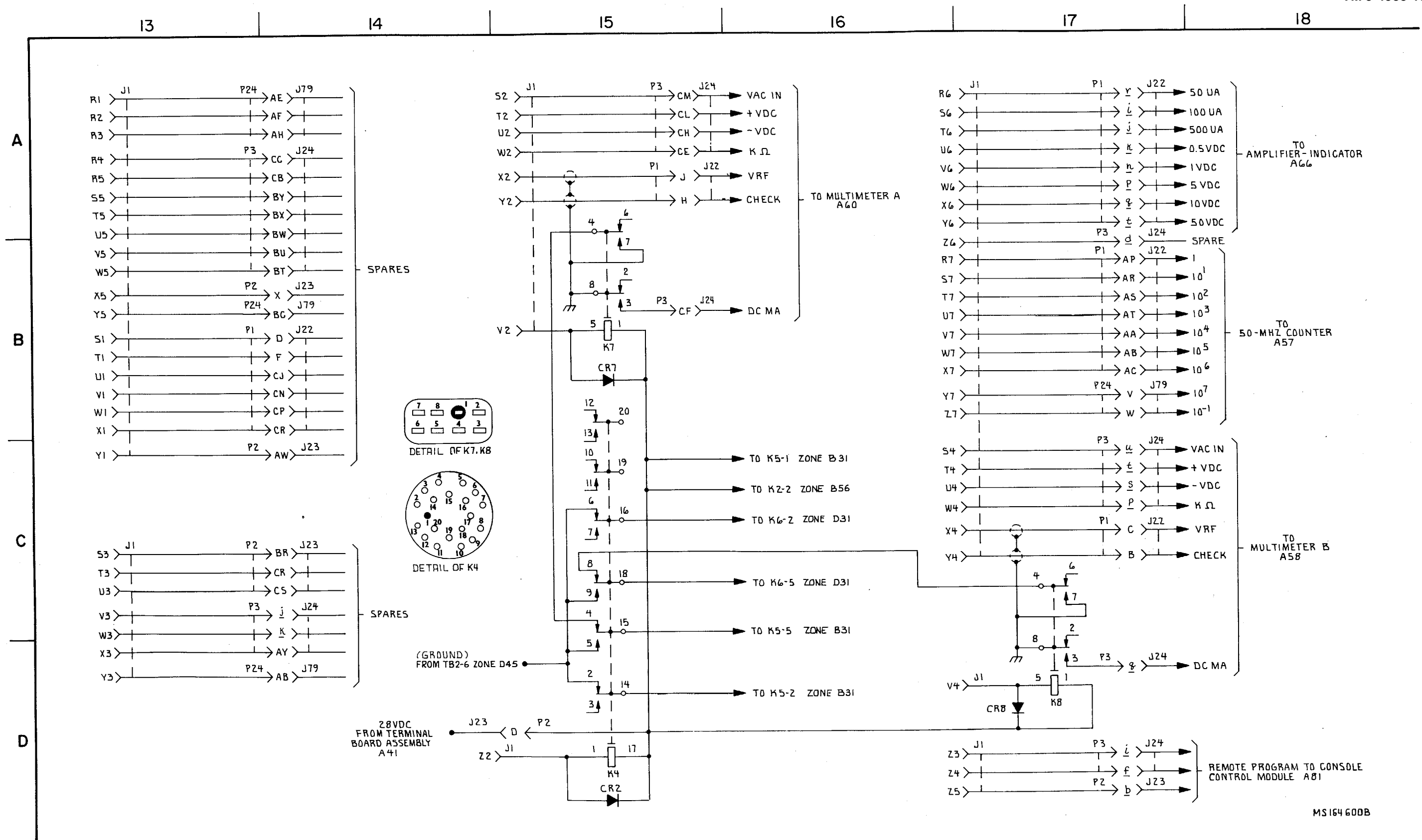

Figure 2-17. Programmer 10670685 (A77) (FG 6450) -schematic (sheet 3 of 10)

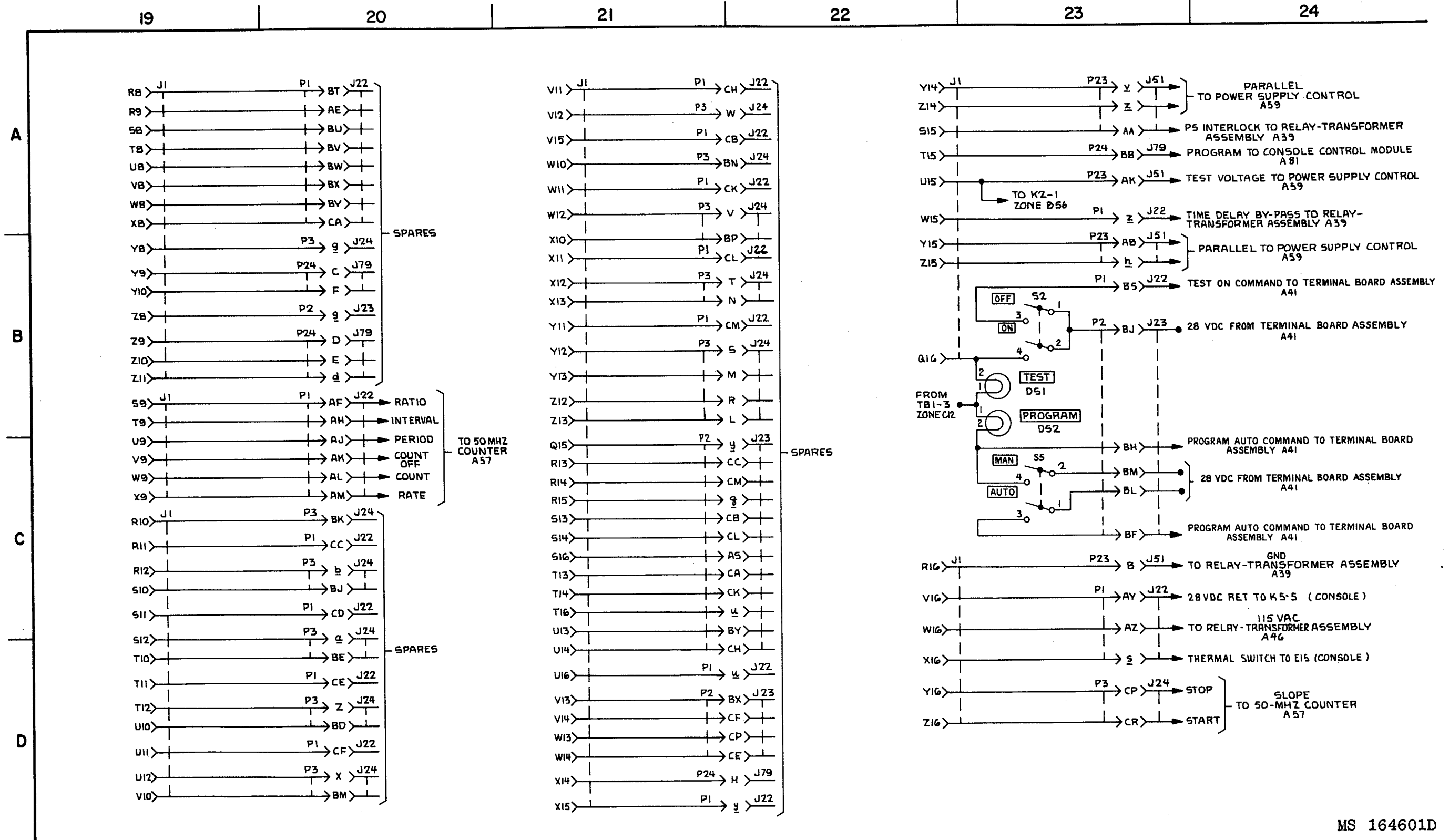
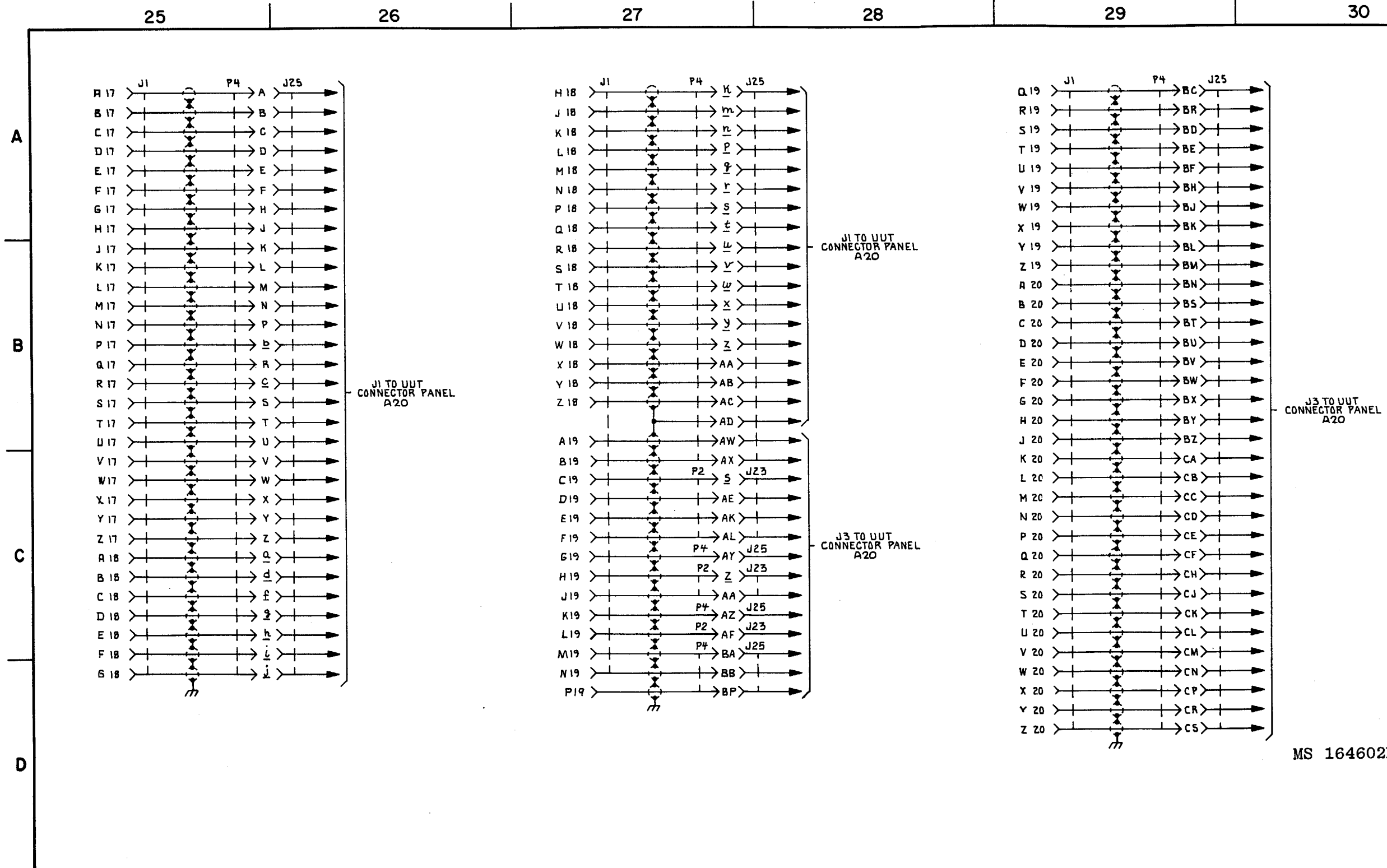

Figure 2-17. Programmer 10670685 (A77) (FG 6450) -schematic (sheet 4 of 10)



MS 164602B

Figure 2-17. Programmer 10670685 (A77) (FG 6450) -schematic (sheet 5 of 10)

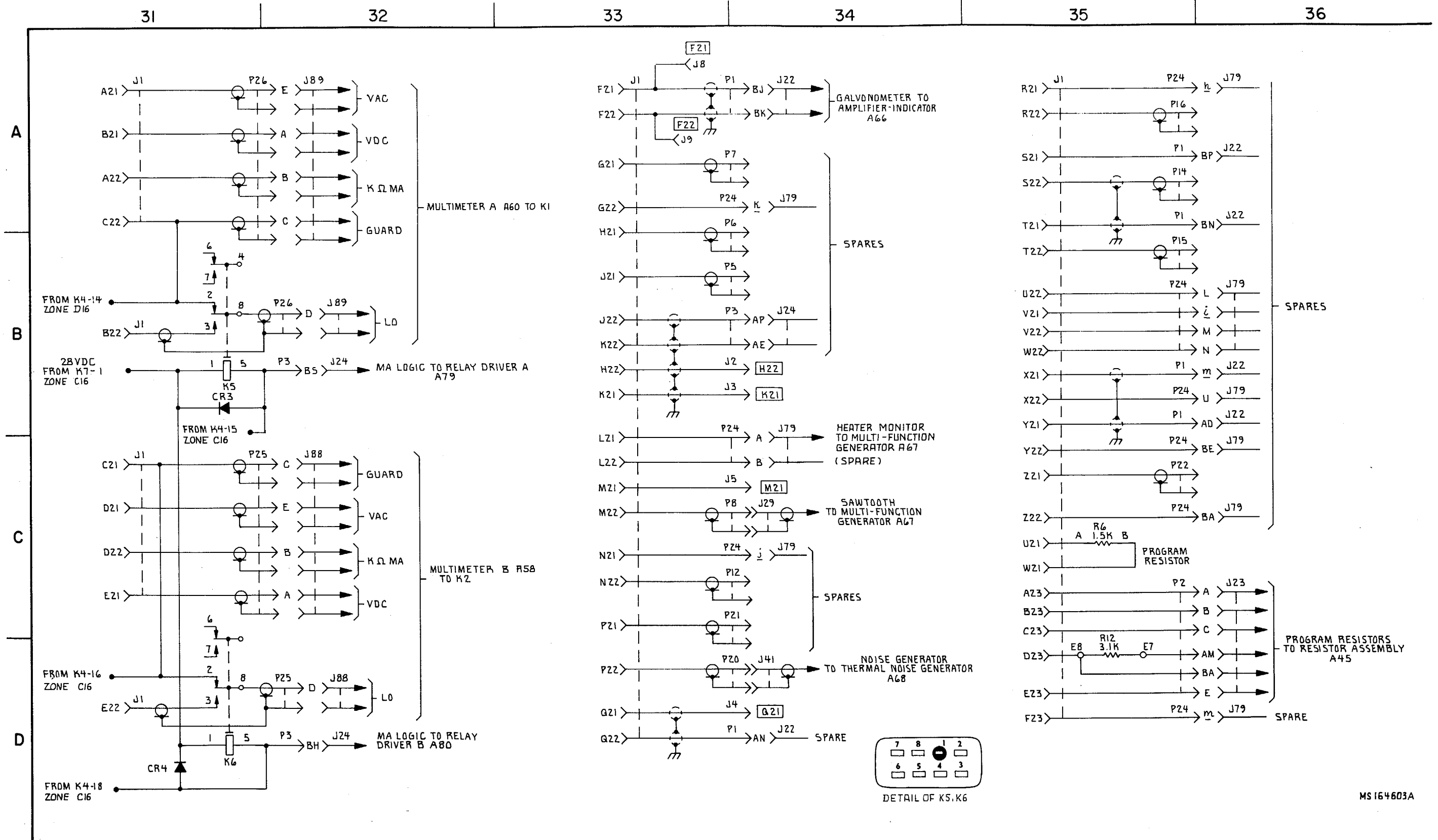

Figure 2-17. Programmer 10670685 (A77) (FG 6450) -schematic (sheet 6 of 10)

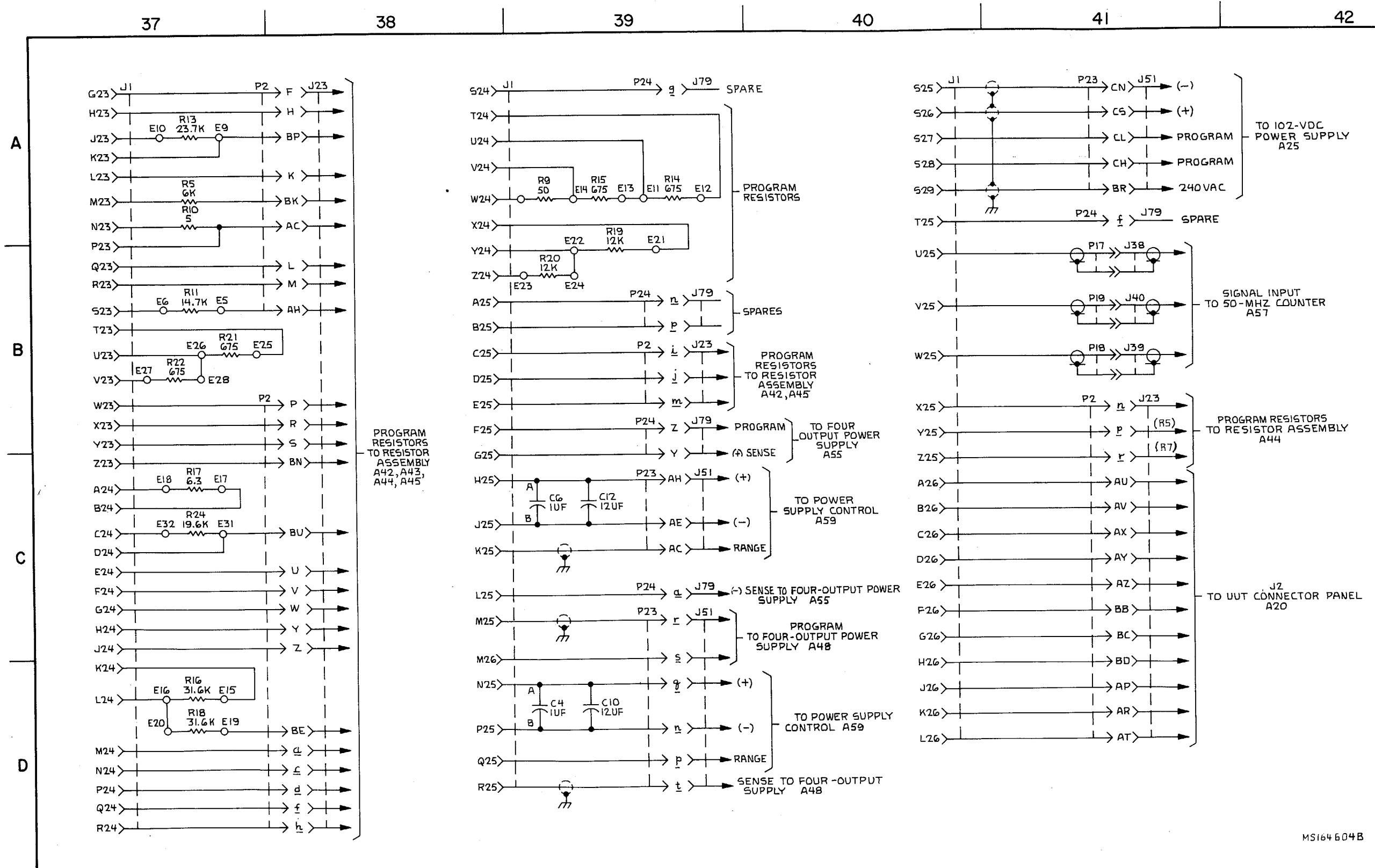

Figure 2-17. Programmer 10670685 (A77) (FG 6450) -schematic (sheet 7 of 10)

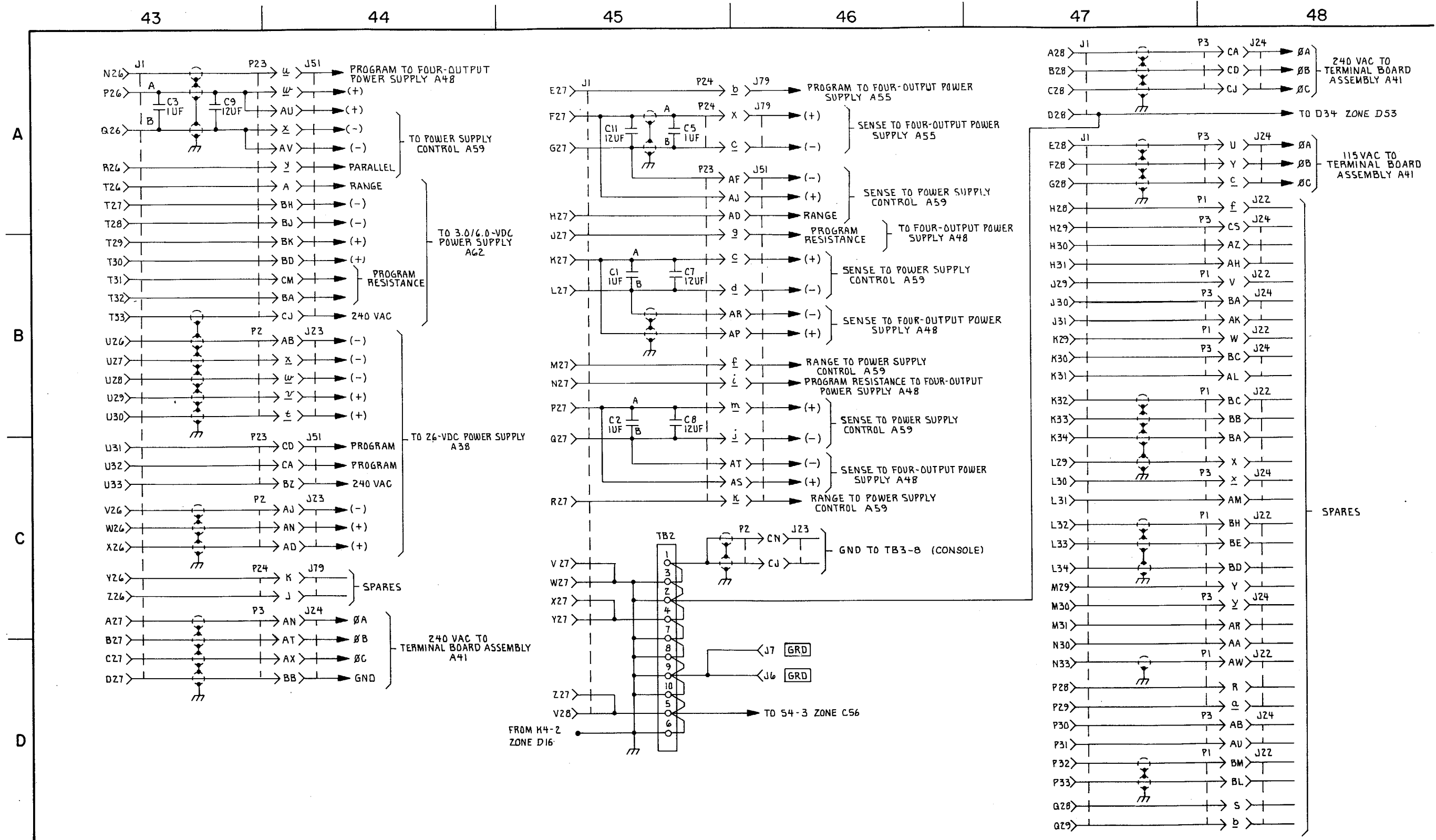

Figure 2-17. Programmer 10670685 (A77) (FG 6450) -schematic (sheet 8 of 10)

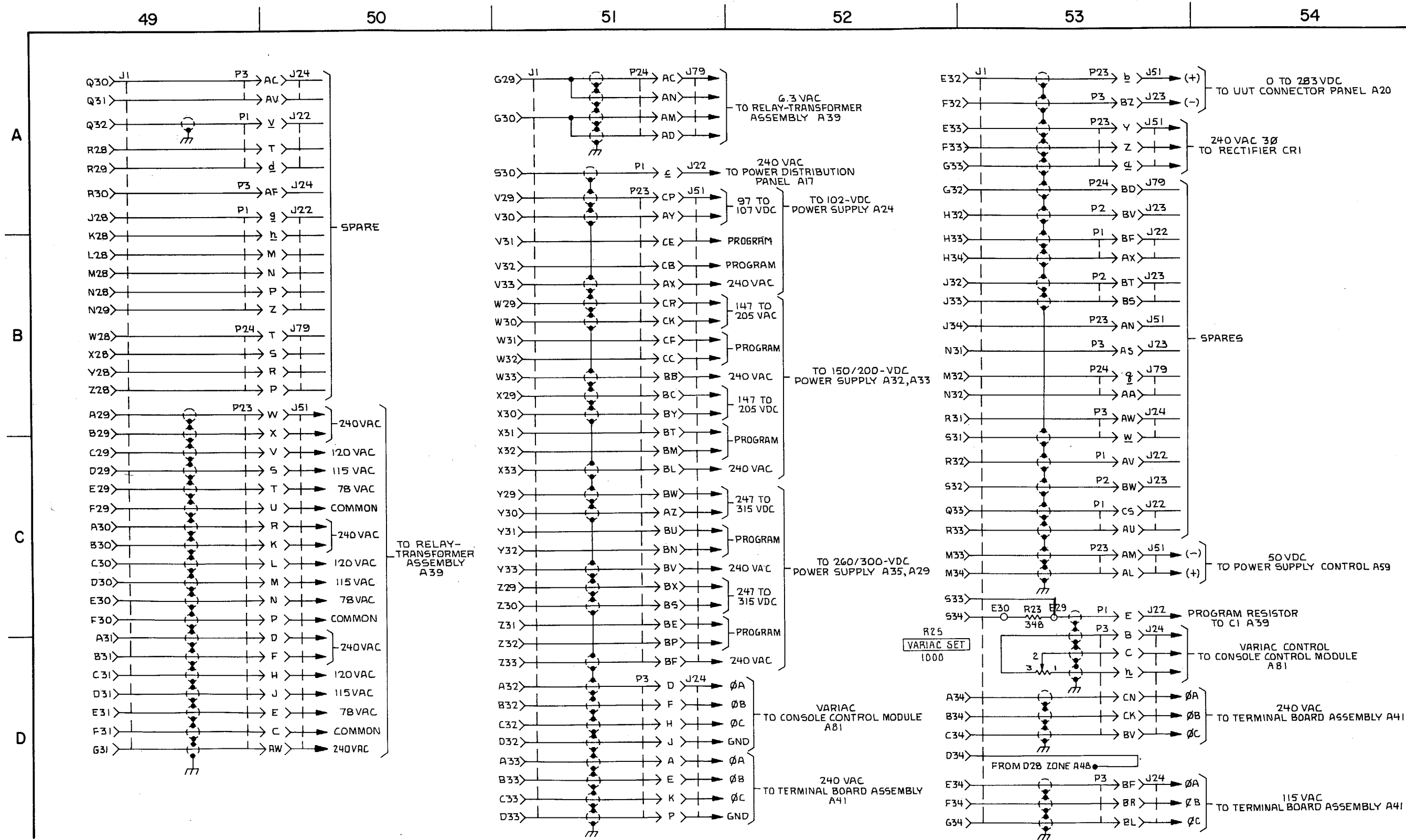
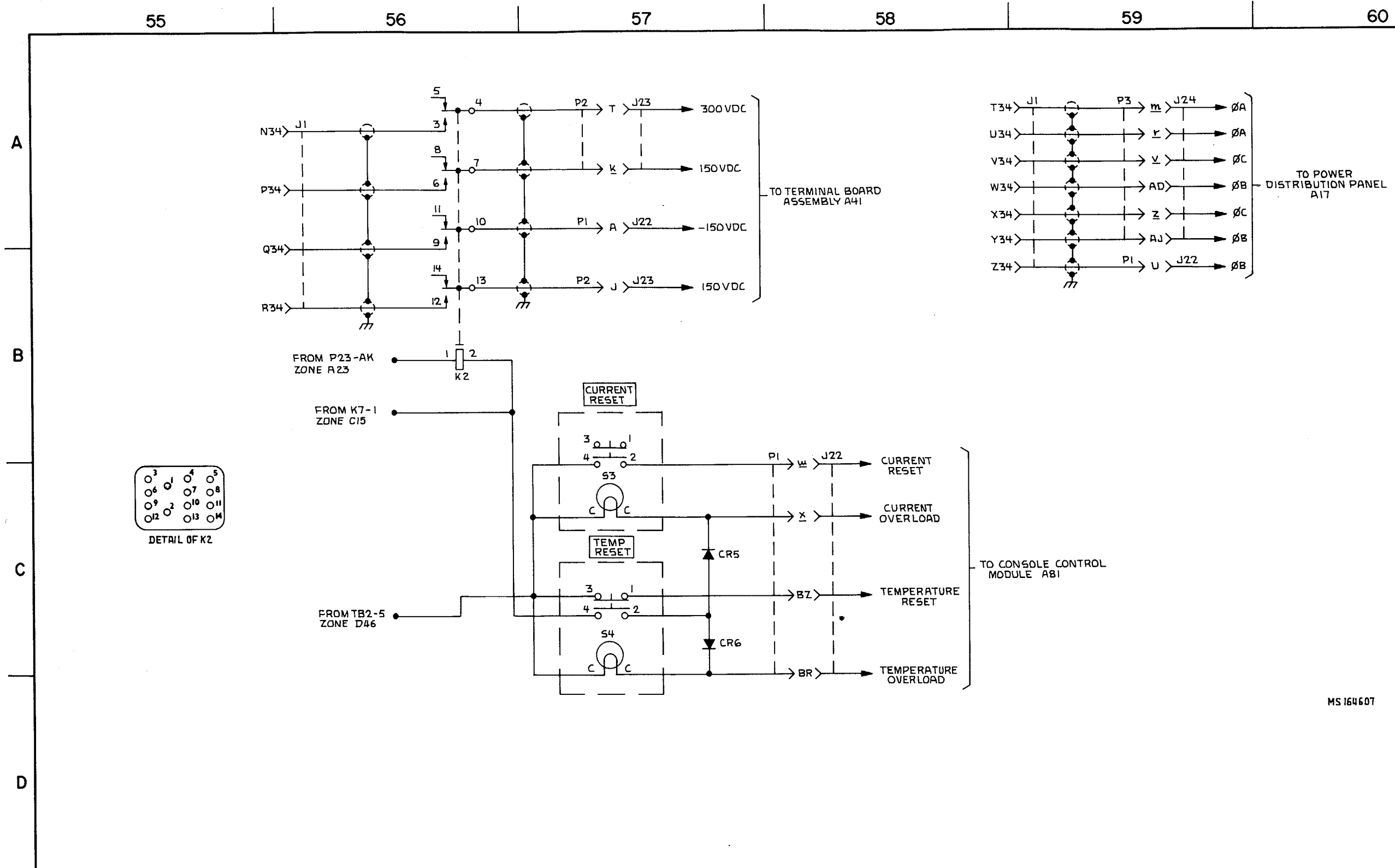
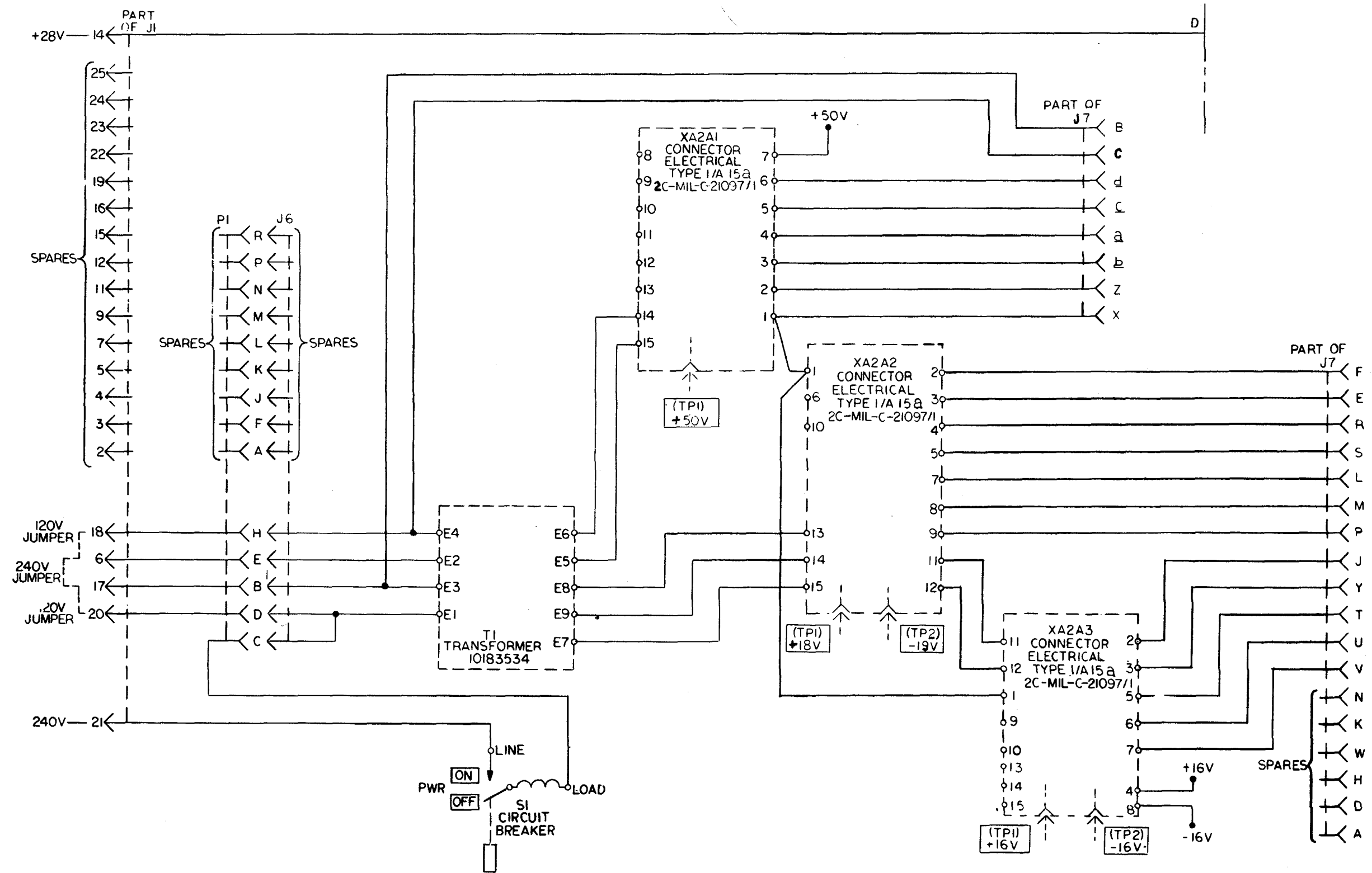

Figure 2-17. Programmer 10670685 (A77) (FG 6450) -schematic (sheet 9 of 10)



MS 164607

Figure 2-17. Programmer 10670685 (A77) (FG 6450) -schematic (sheet 10 of 10)



MI 69873

Figure 2-18. Signal Generator 10182039 (A69) (FG 3800)-schematic (sheet 1 of 3).

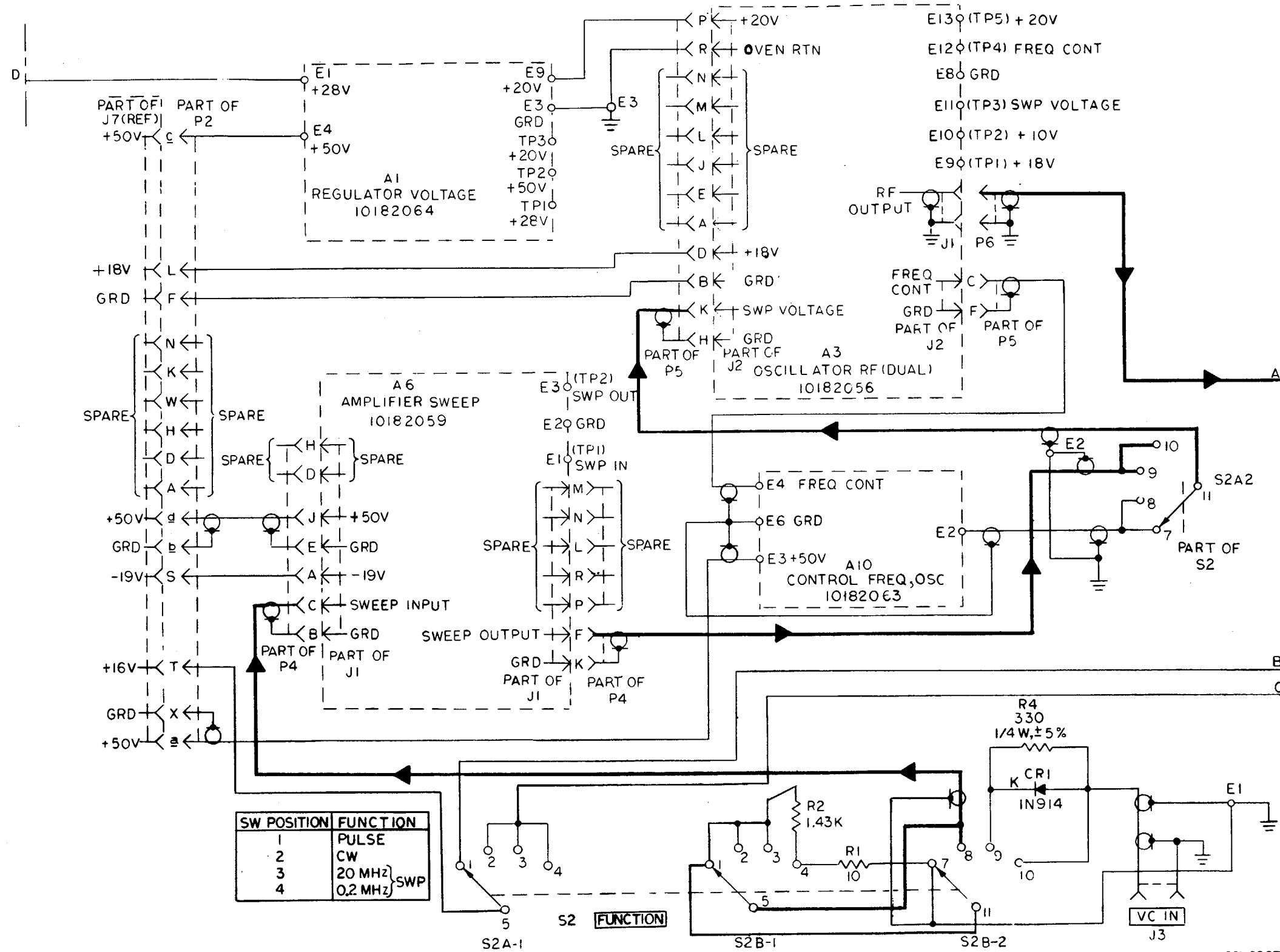

MI 69874

Figure 2-18. Signal Generator 10182039 (A69) (FG 3800) - schematic (sheet 2 of 3)

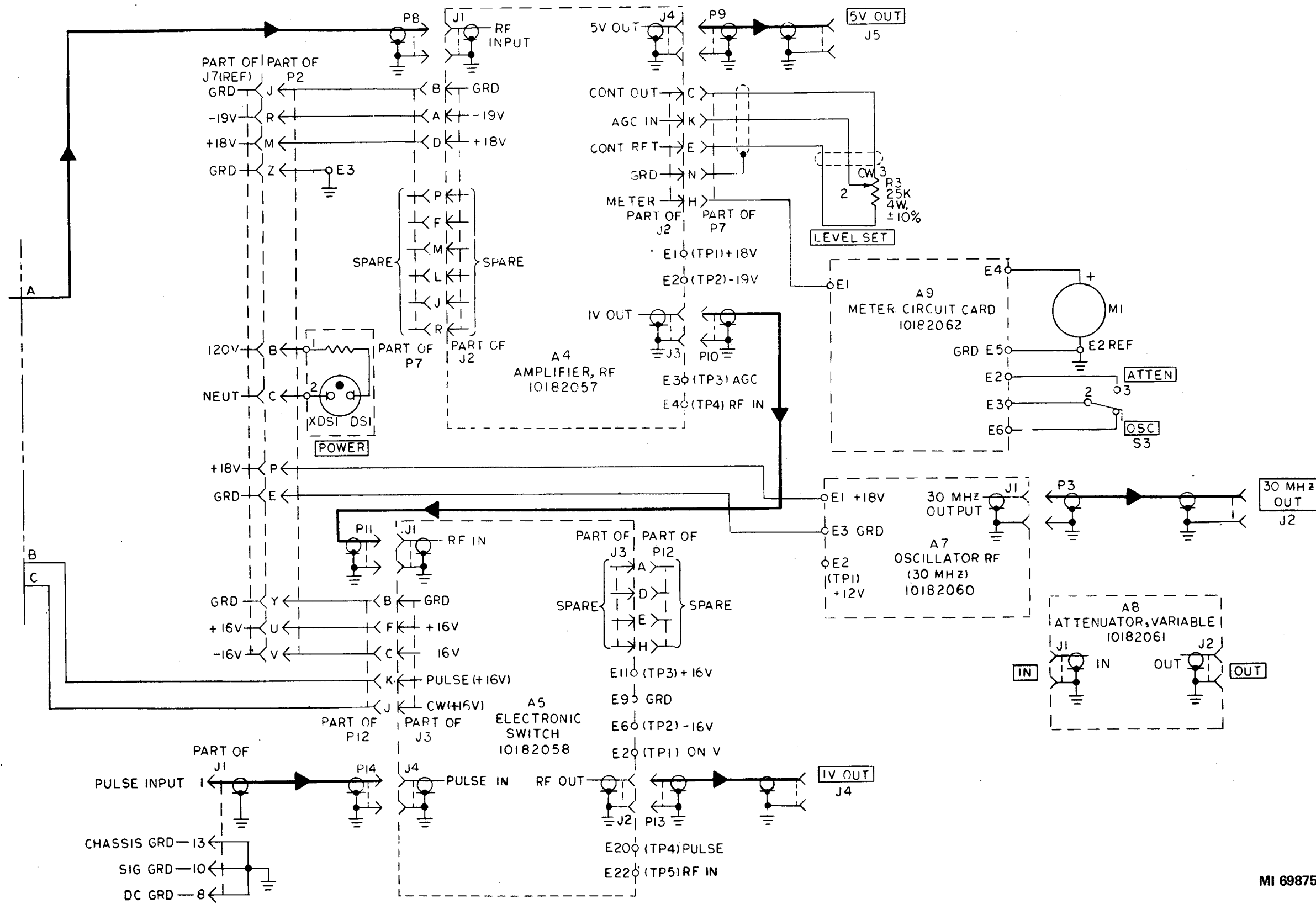

Figure 2-18. Signal Generator 10182039 (A69) (FG 3800) - schematic (sheet 3 of 3)

MI 69875

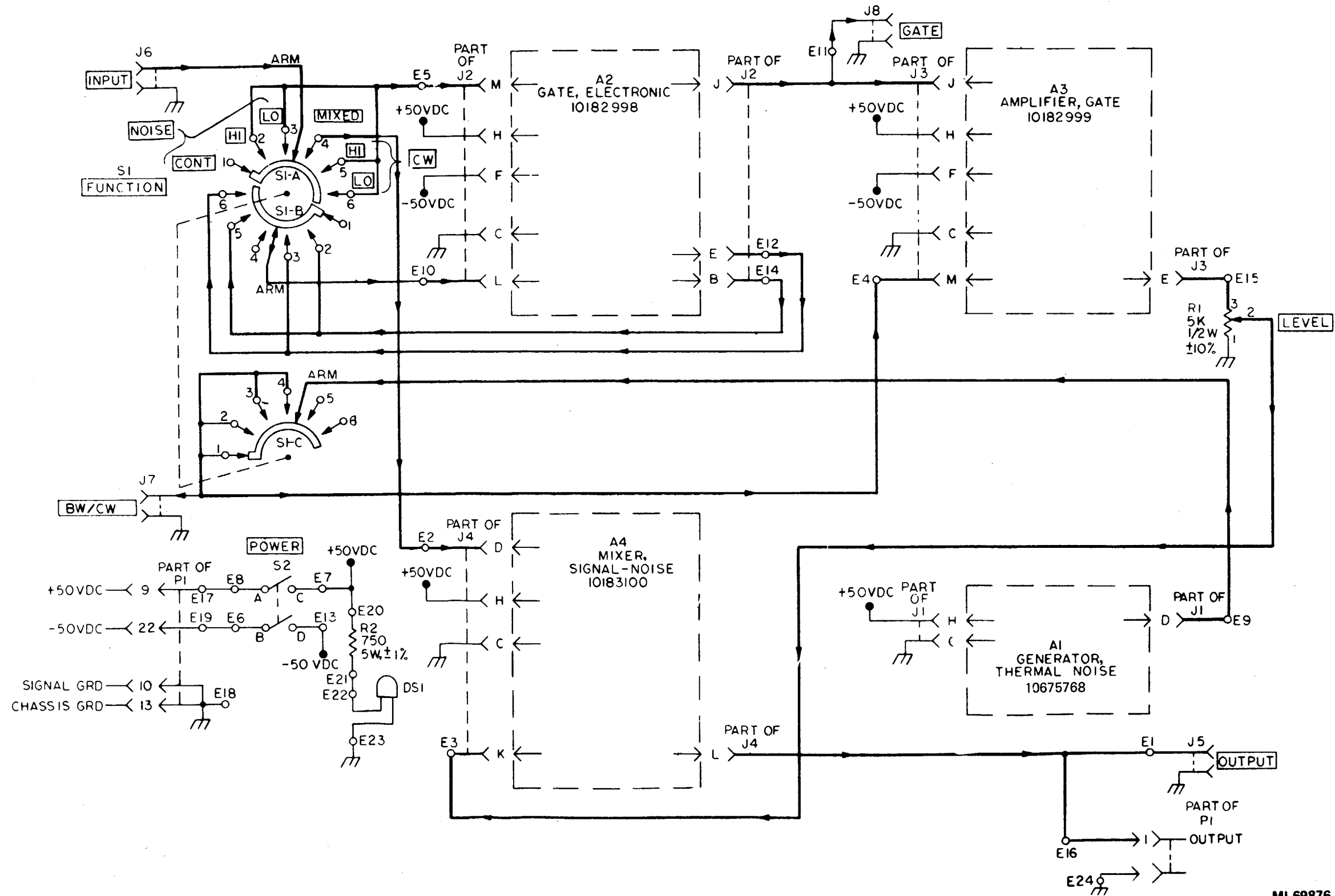
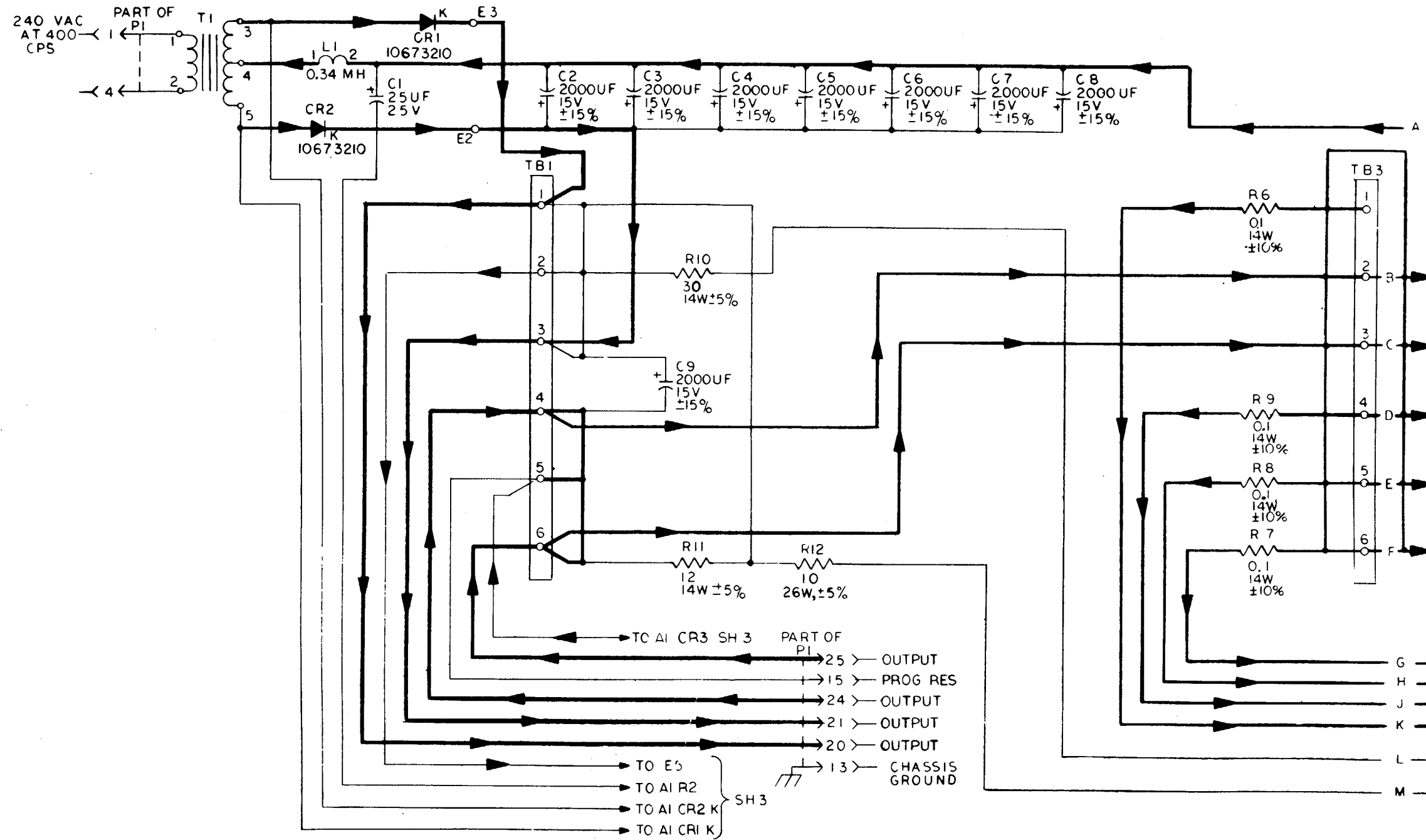

Figure 2-19. Thermal-noise generator 10182651 (A68) (FG 3600) - schematic

MI 69876



SEE SHEET 2
MI 69877B

Figure 2-20. 3.0/6.0 Vdc power supply 10182658 (A62) (FG 5600) - schematic (sheet 1 of 3)

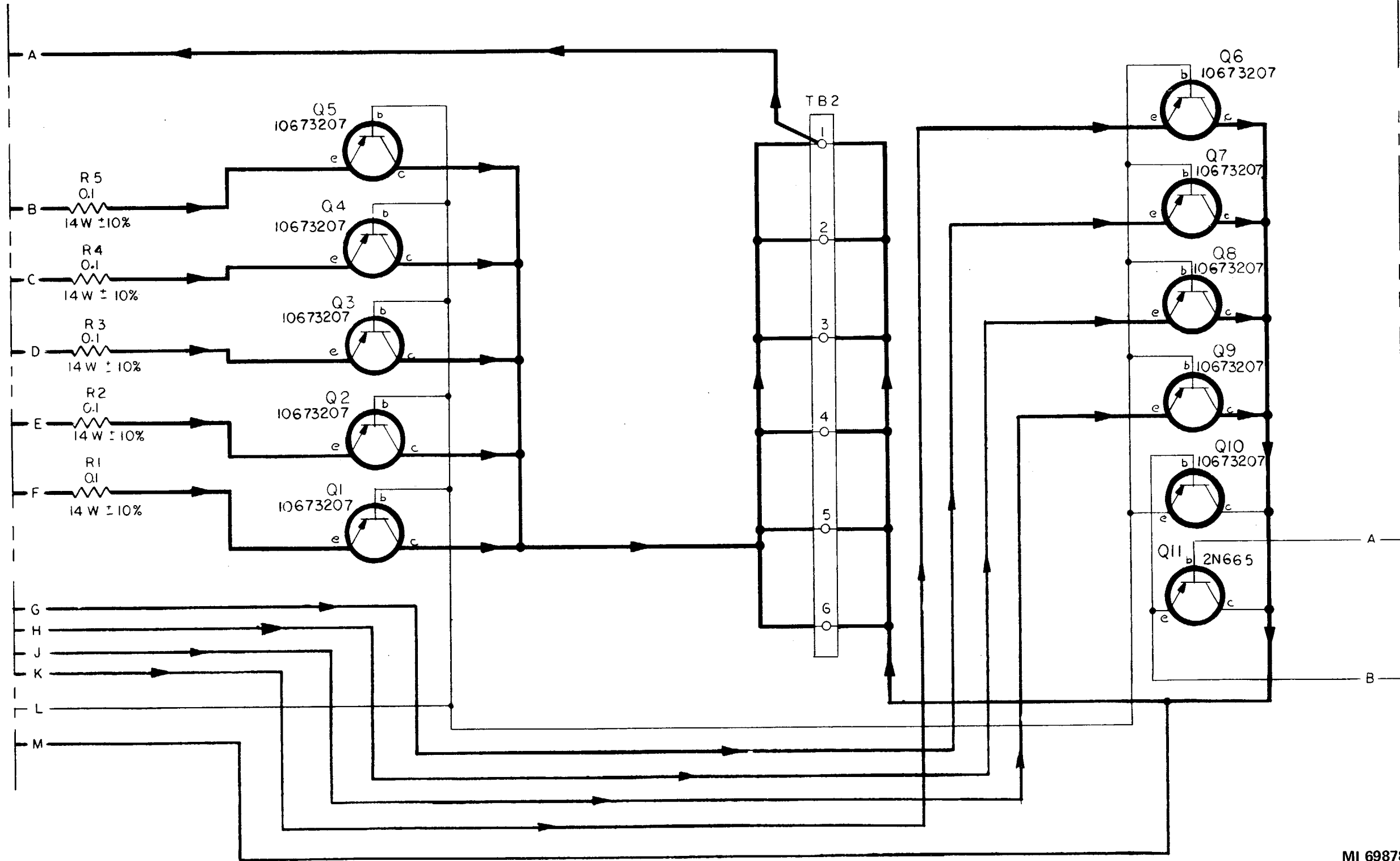

MI 69878

Figure 2-20. 3.0/6.0 Vdc power supply 10182658 (A62) (FG 5600) - schematic (sheet 2 of 3)

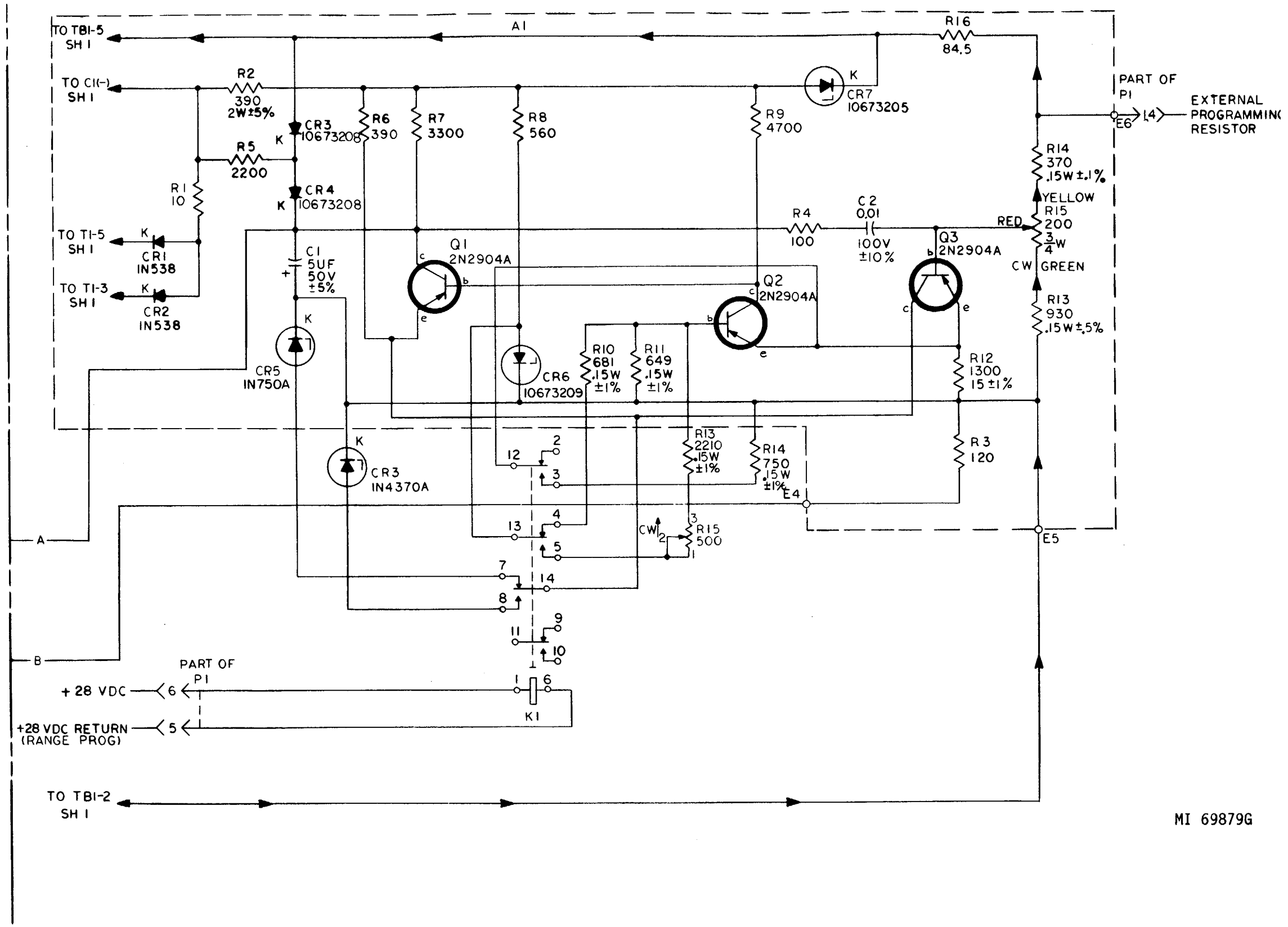

SEE SHEET 2

MI 69879G

Figure 2-20. 3.0/6.0 Vdc power supply 10182658 (A62) (FG 5600) - schematic (sheet 3 of 3)

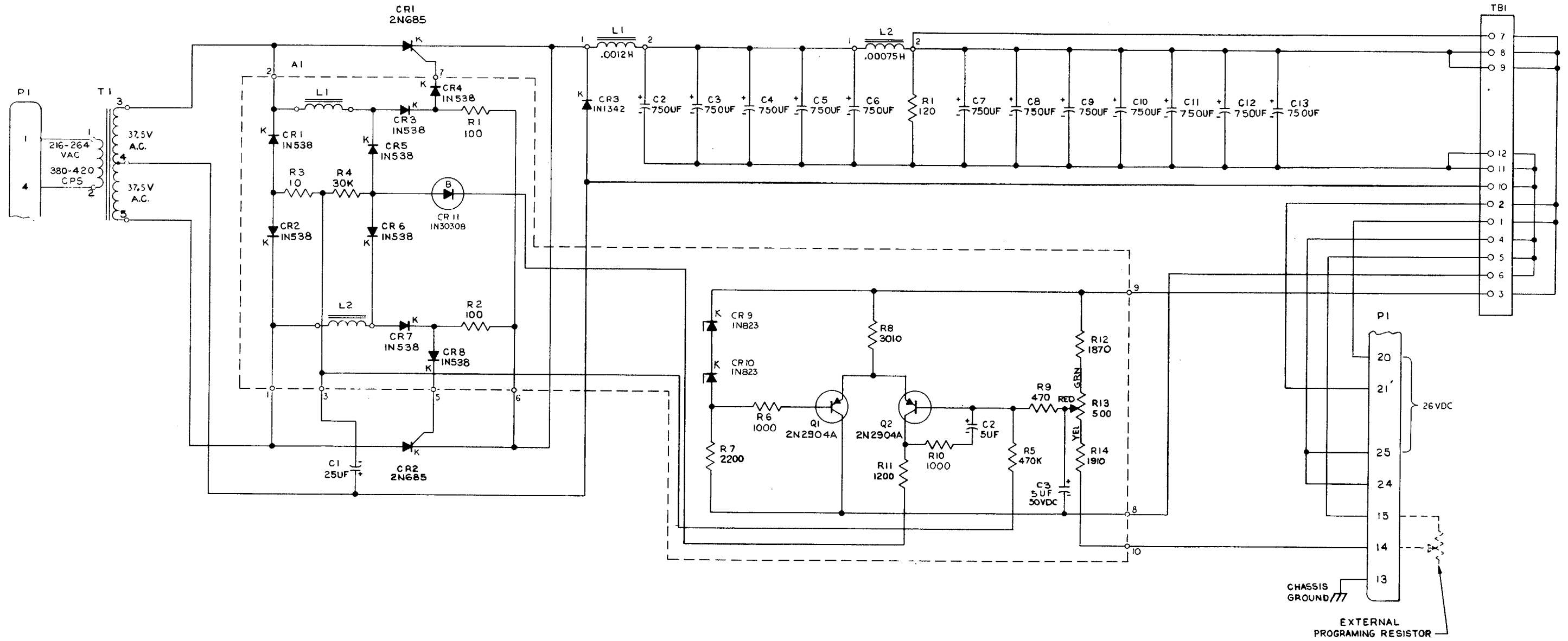

Figure 2-21. 26-Vdc power supply 10180942 (A38) (FG 6000) - schematic

MI 69880F

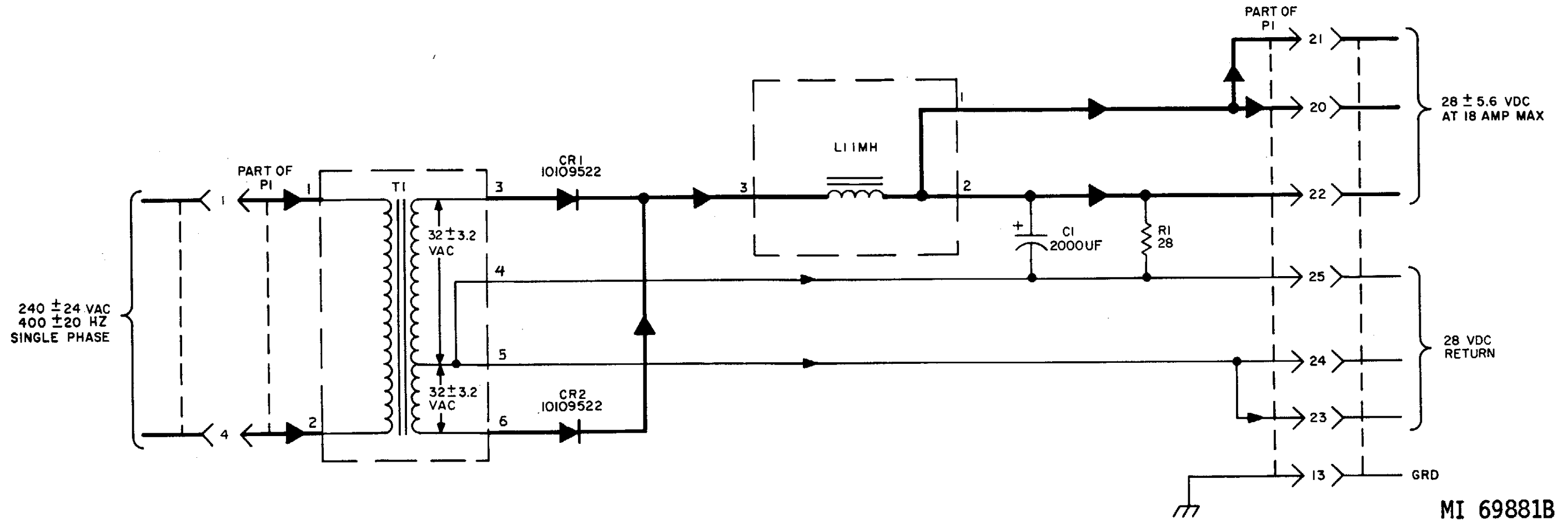

Figure 2-22. 28- Vdc power supply 9188025 (A37) (FG 3200) - schematic

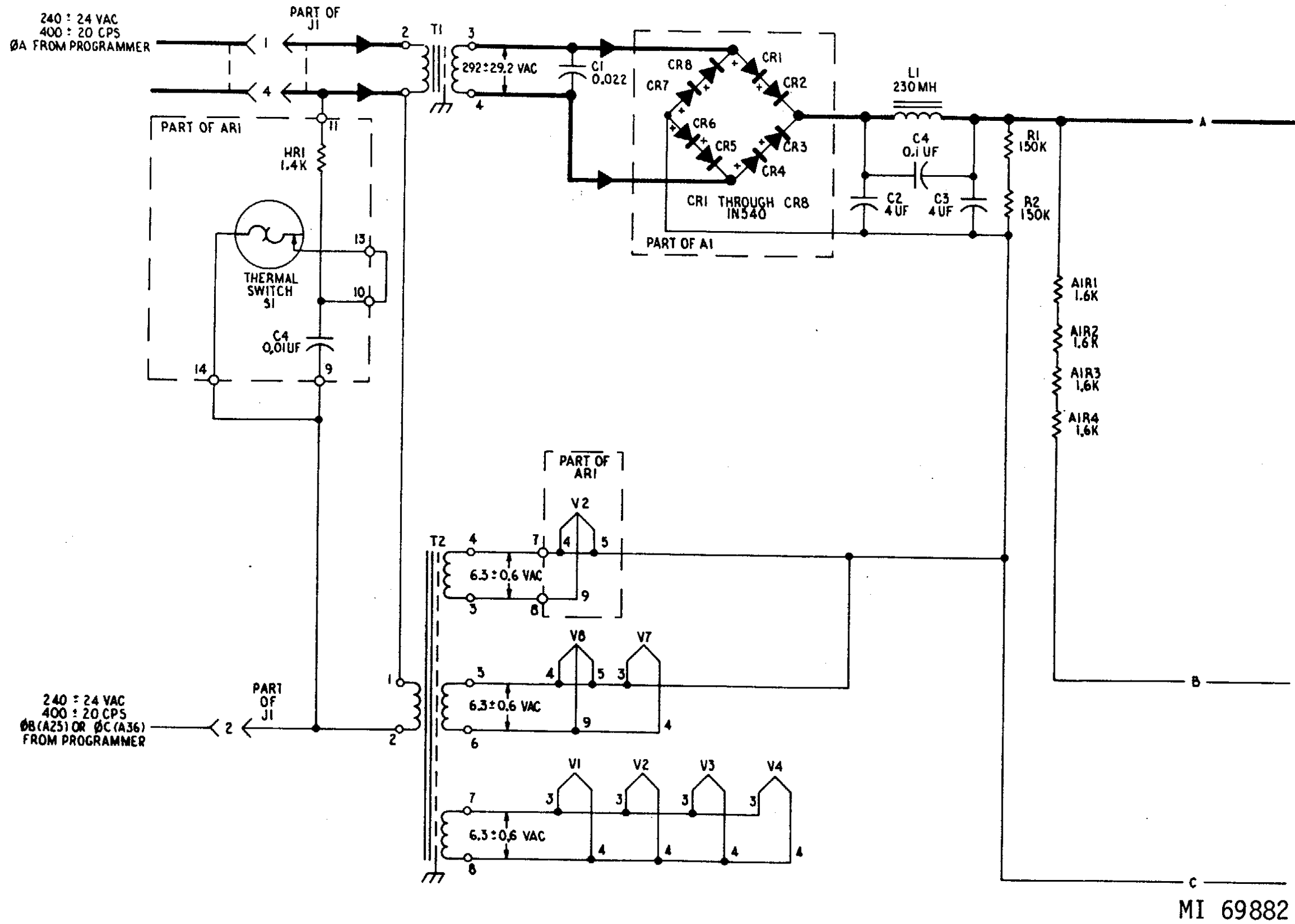
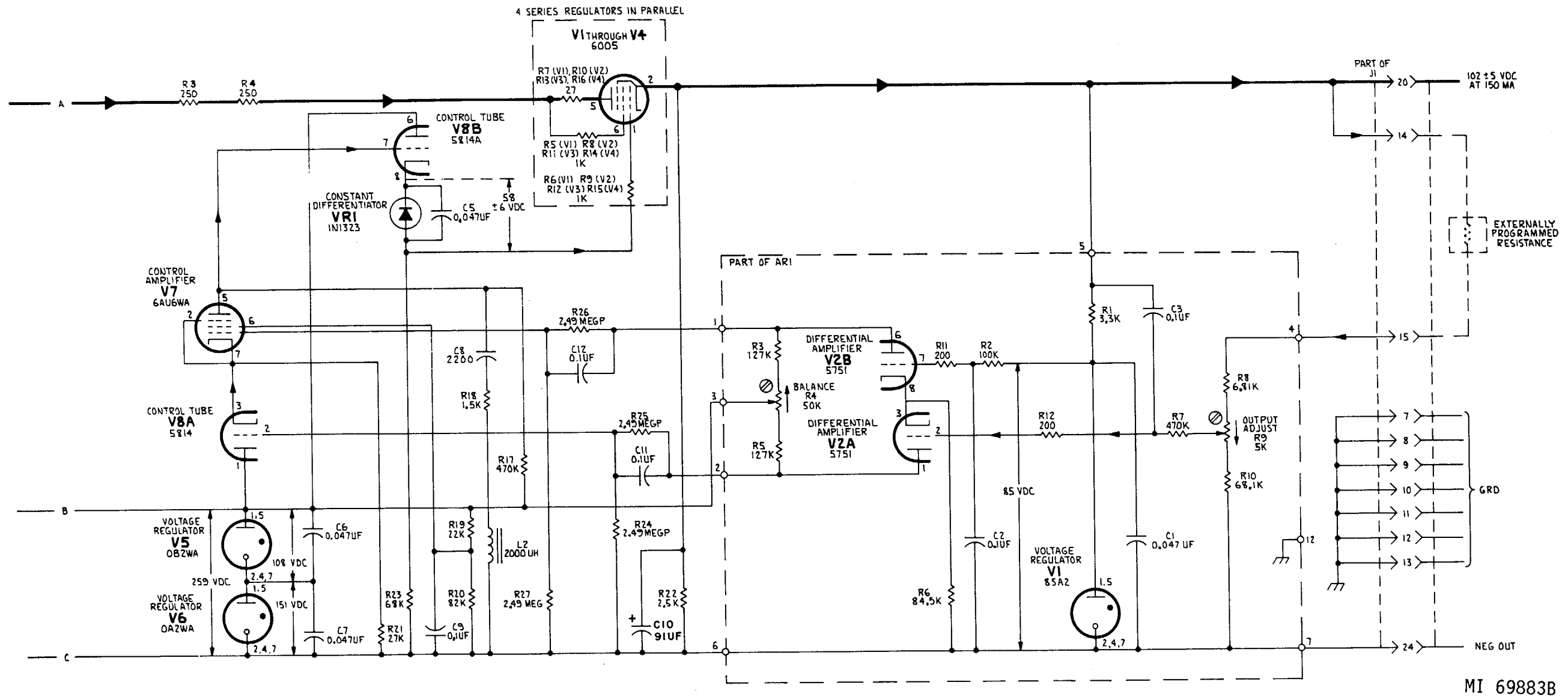

Figure 2-23. 102-Vdc power supply 10110081 (A24, A25) (FG 5400) - schematic (sheet 1 of 2)



MI 69883B

Figure 2-23. 102-Vdc power supply 10110081 (A24, A25) (FG 5400) - schematic (sheet 2 of 2).

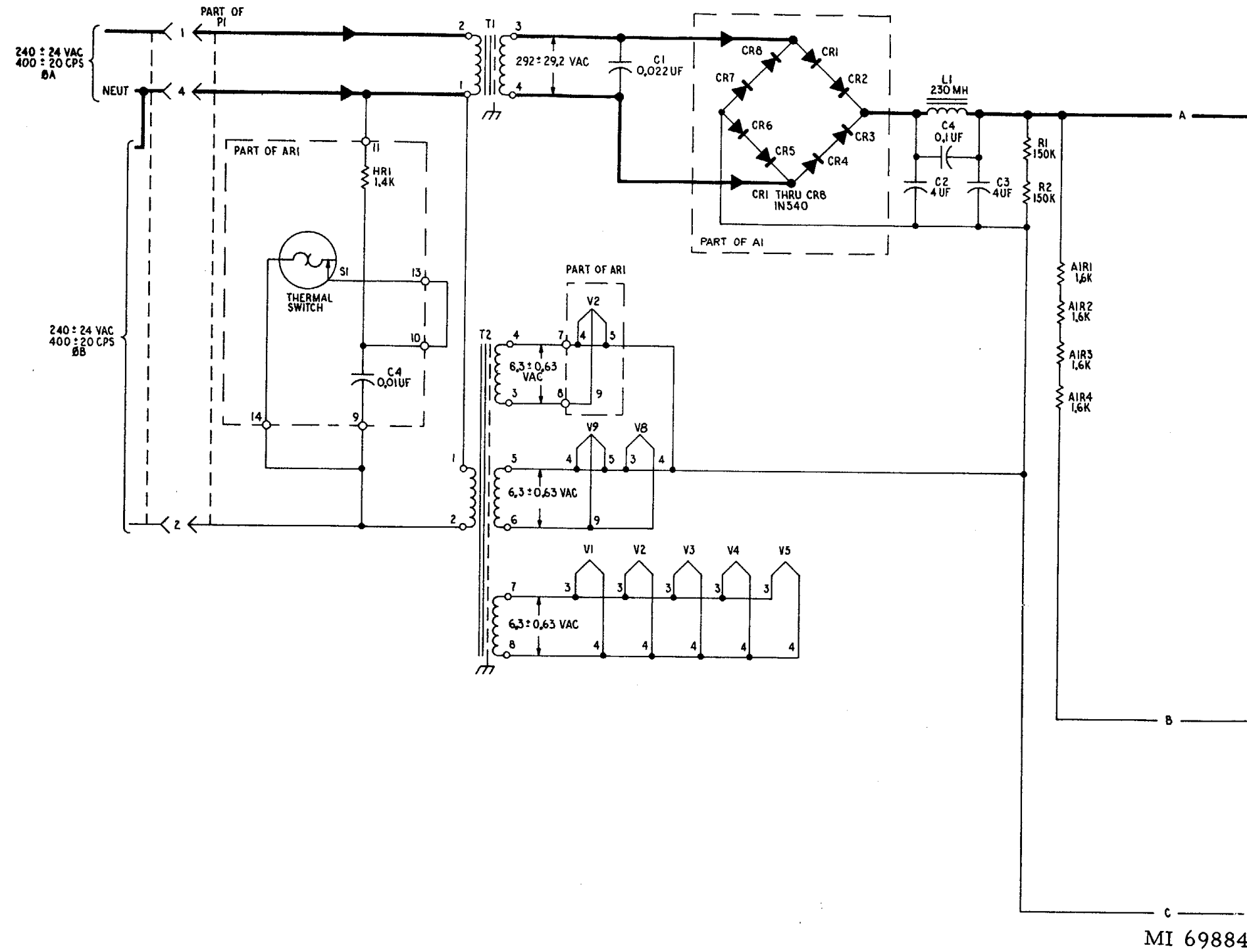
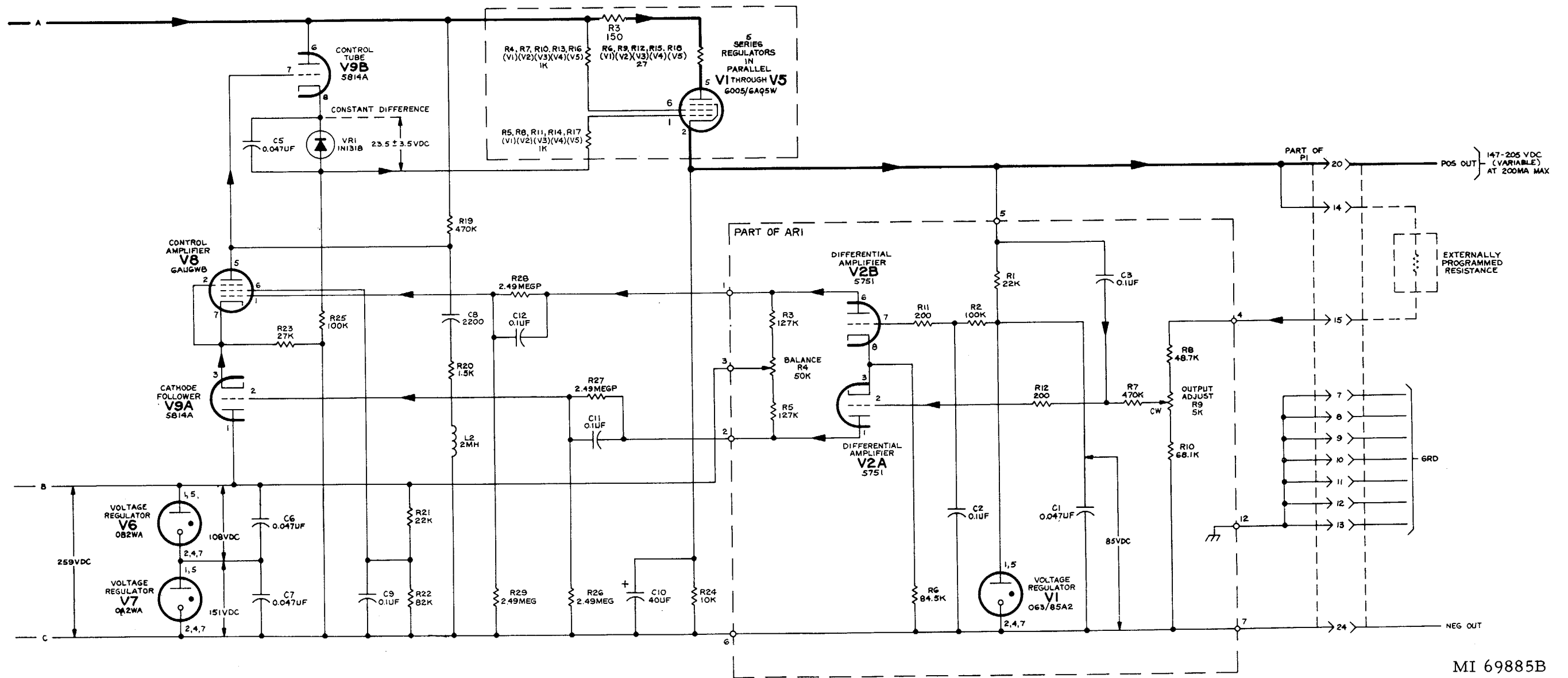

Figure 2-24. 150/200 Vdc power supply 10110015 (A28, A31, A32, A33, A34,) (FG 3400) - (sheet 1 of 2).



MI 69885B

Figure 2-24. 150/200 Vdc power supply 10110015 (A28, A31, A32, A33, A34,) (FG 3400) - (sheet 2 of 2).

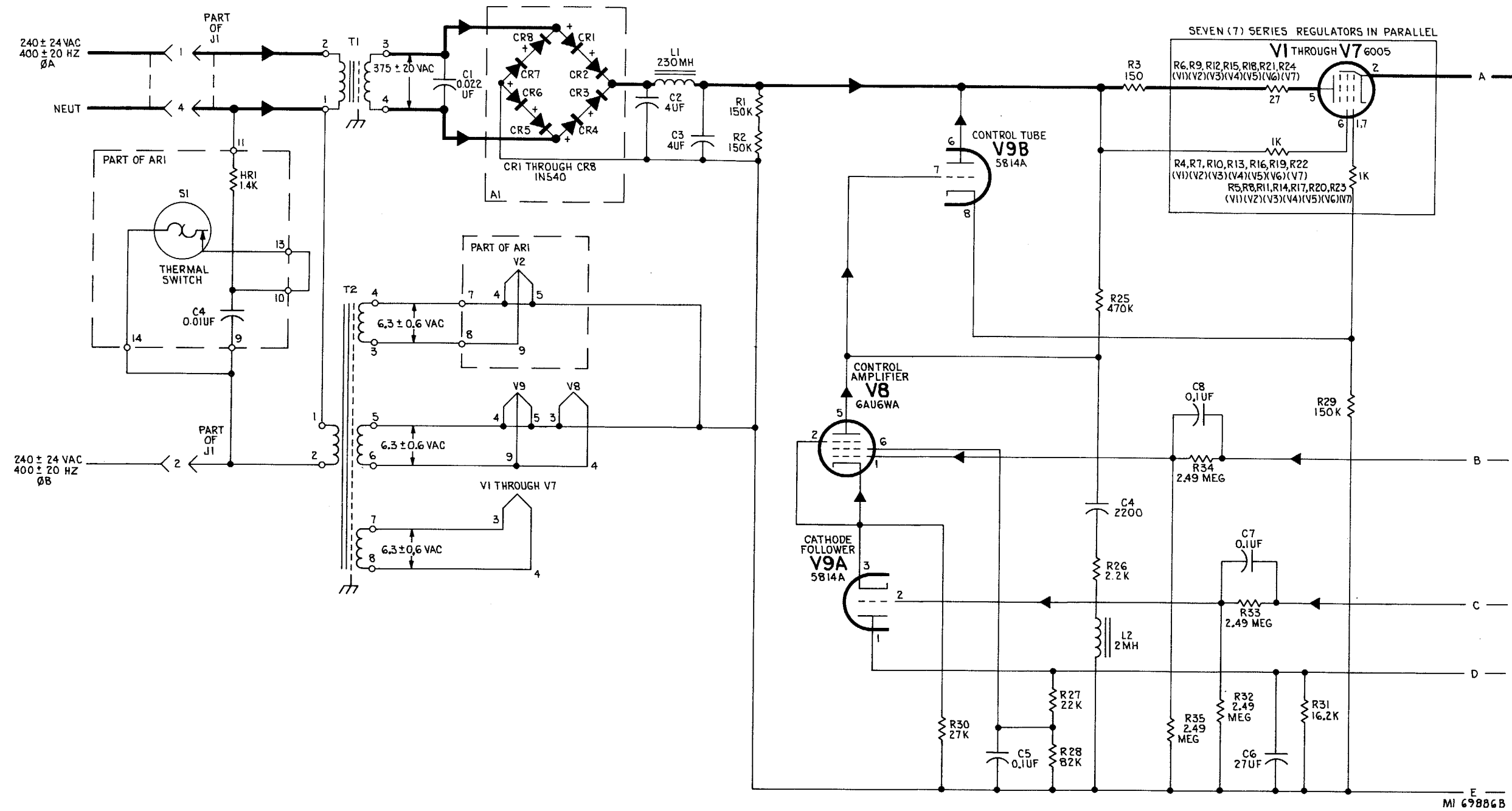

Figure 2-25. 260/300 Vdc power supply 10110086 (A29, A30, A35) (FG 5800) - schematic (sheet 1 of 2).

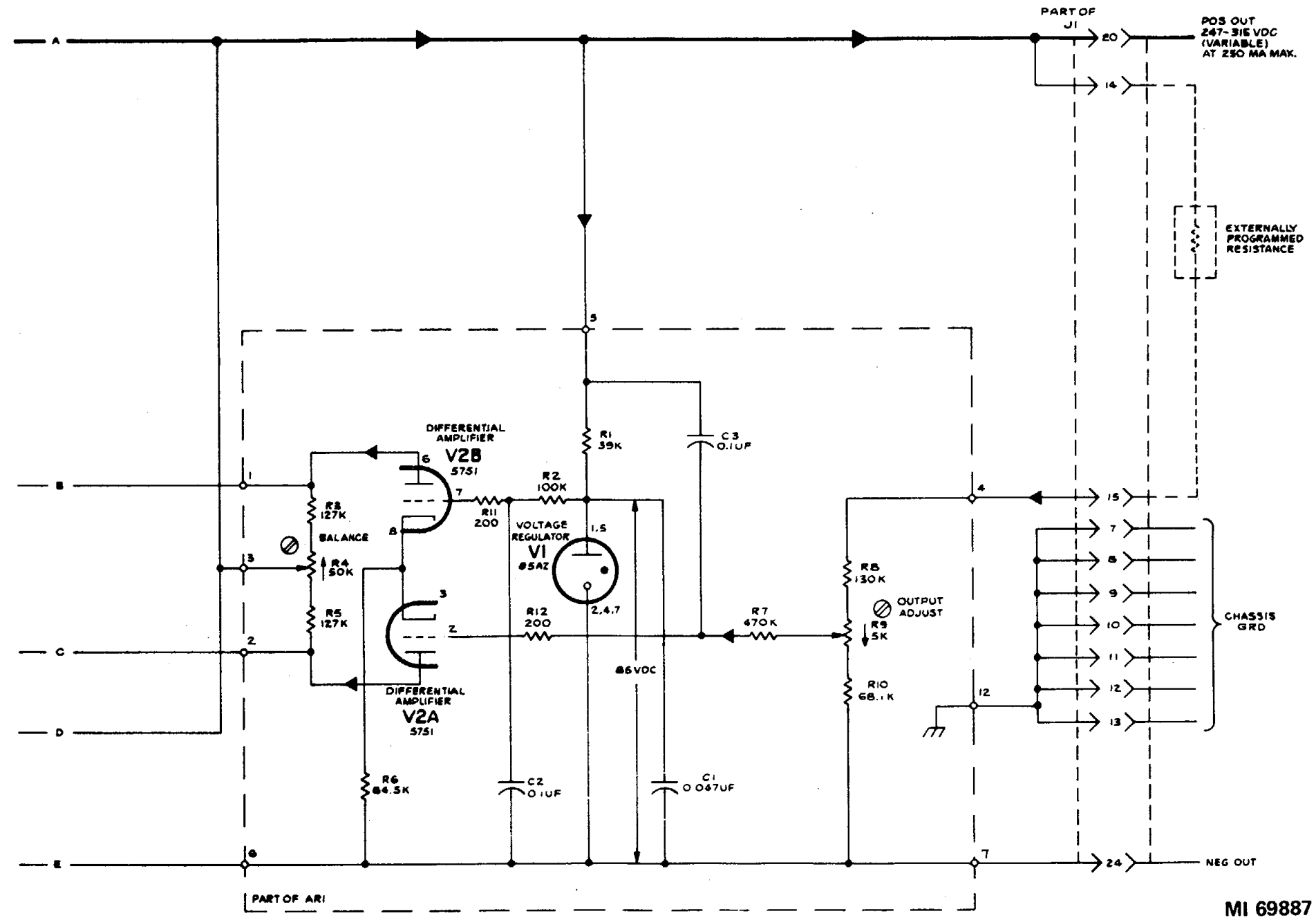

Figure 2-25. 260/300 Vdc power supply 10110086 (A29, A30, A35) (FG 5800) - schematic (sheet 2 of 2).

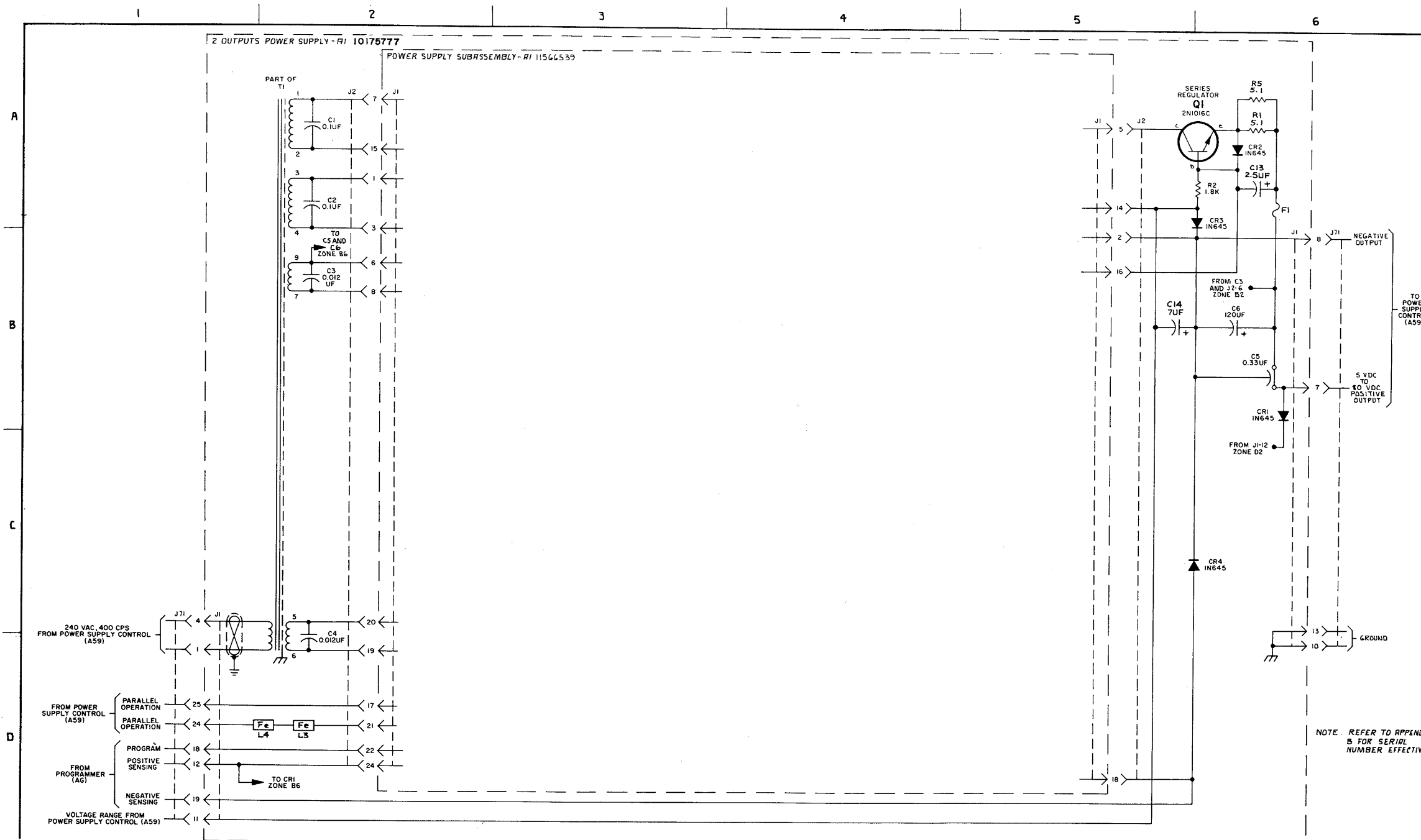

Figure 2-26. Four-output power supply 10175776 (A48, A55) * (L) (see note) (FG 4200) - schematic (sheet 1 of 2).

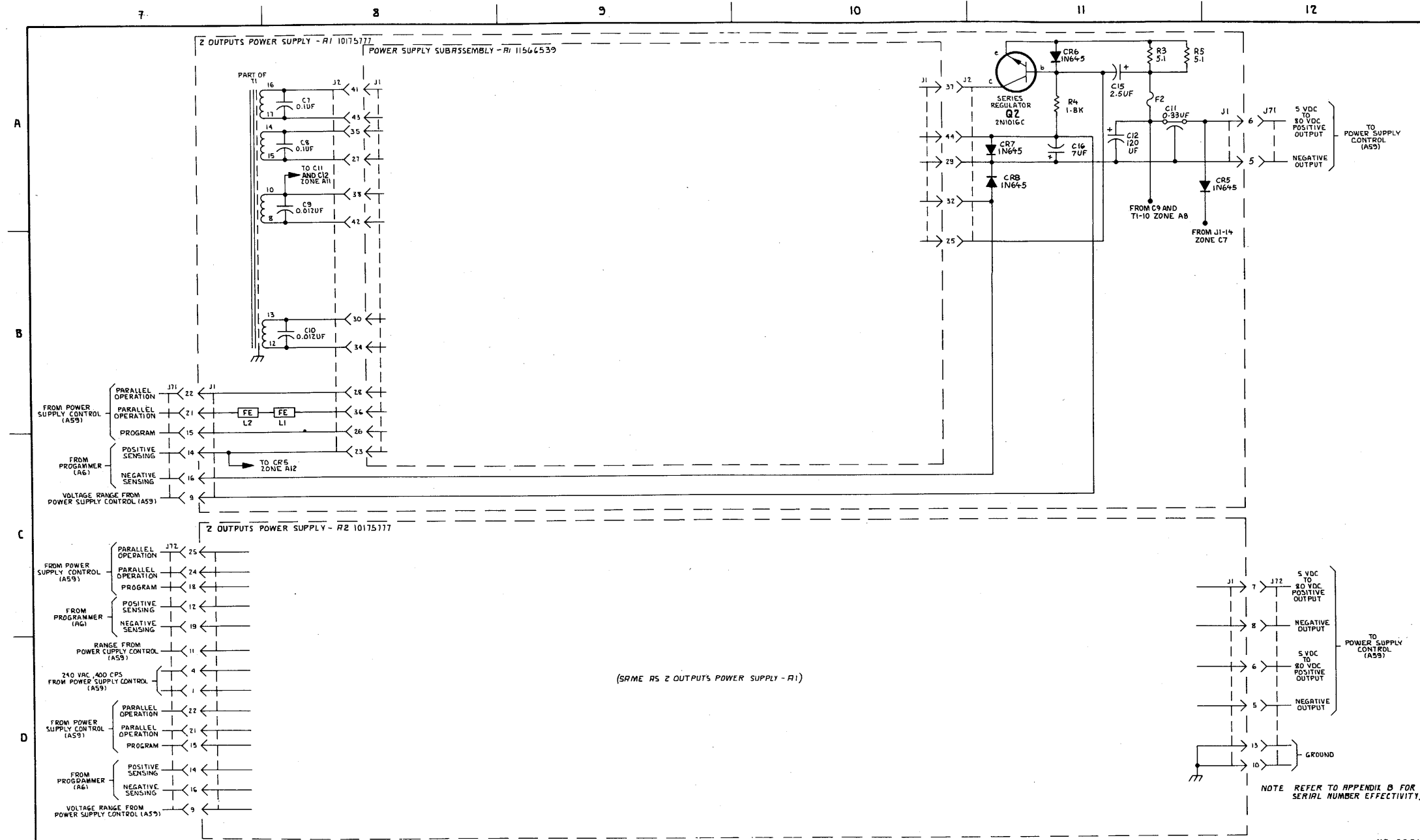
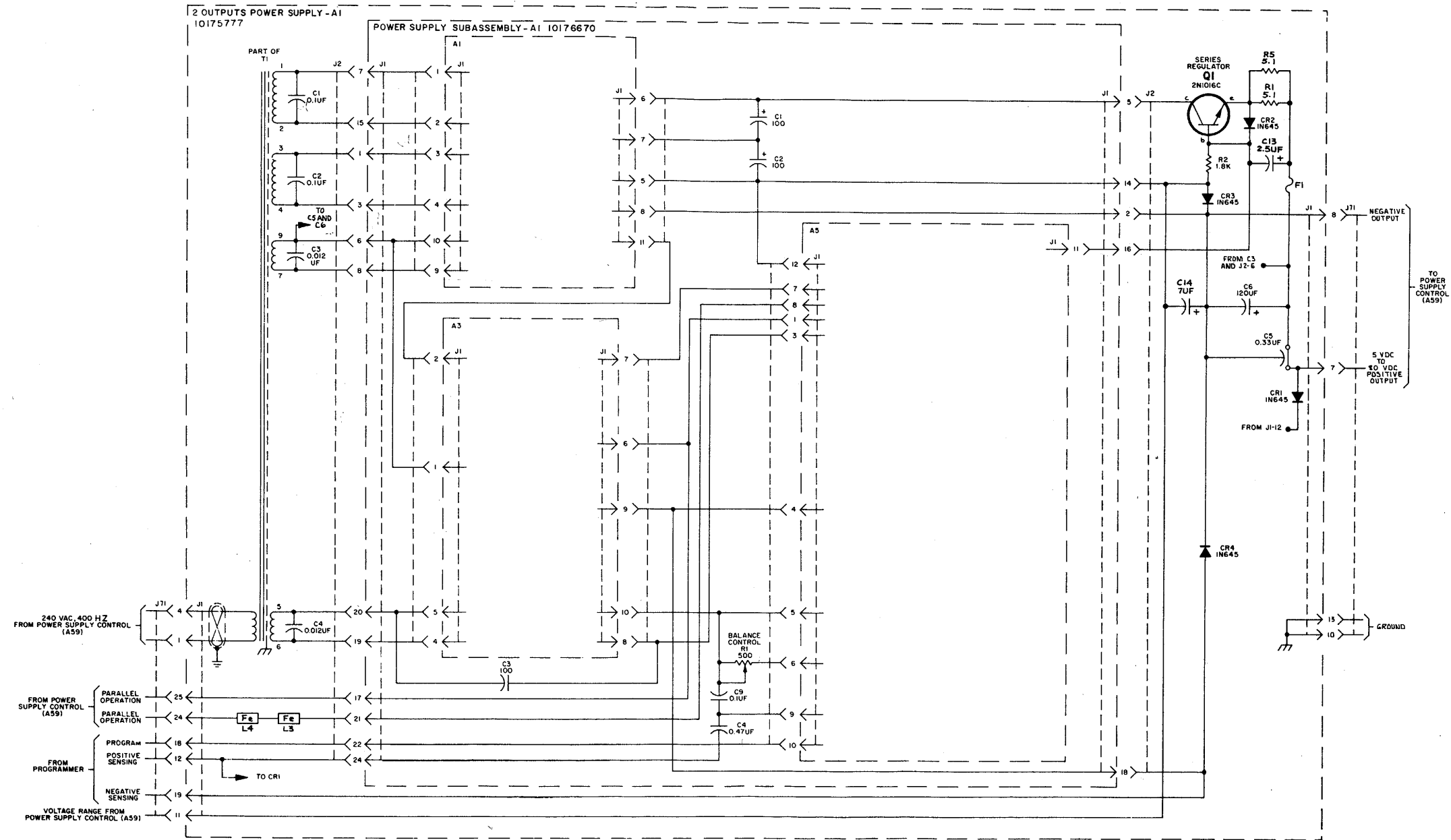

Figure 2-26. Four-output power supply 10175776 (A48, A55) * (L) (see note) (FG 4200) - schematic (sheet 2 of 2).



Note. Refer to appendix B for serial number effectivity.

MI 69888D

Figure 2-27. Four-output power supply 10175776 (A48, A55) * (K) (see note) (FG 4200) - schematic (sheet 1 of 2).

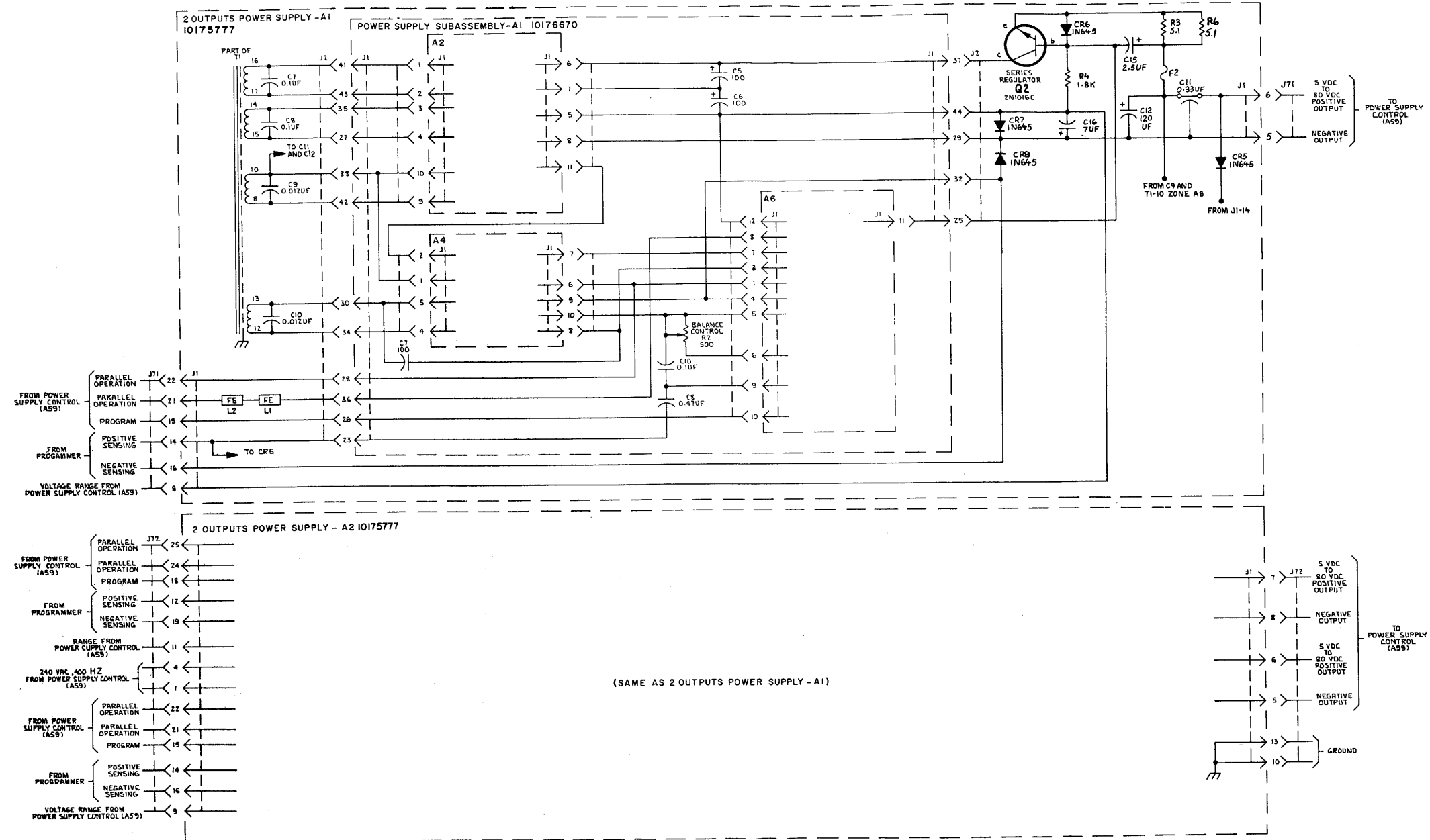

Note. Refer to appendix B for serial number effectivity.

MI 69889D

Figure 2-26. Four-output power supply 10175776 (A48, A55) * (K) (see note) (FG 4200) - schematic (sheet 2 of 2).

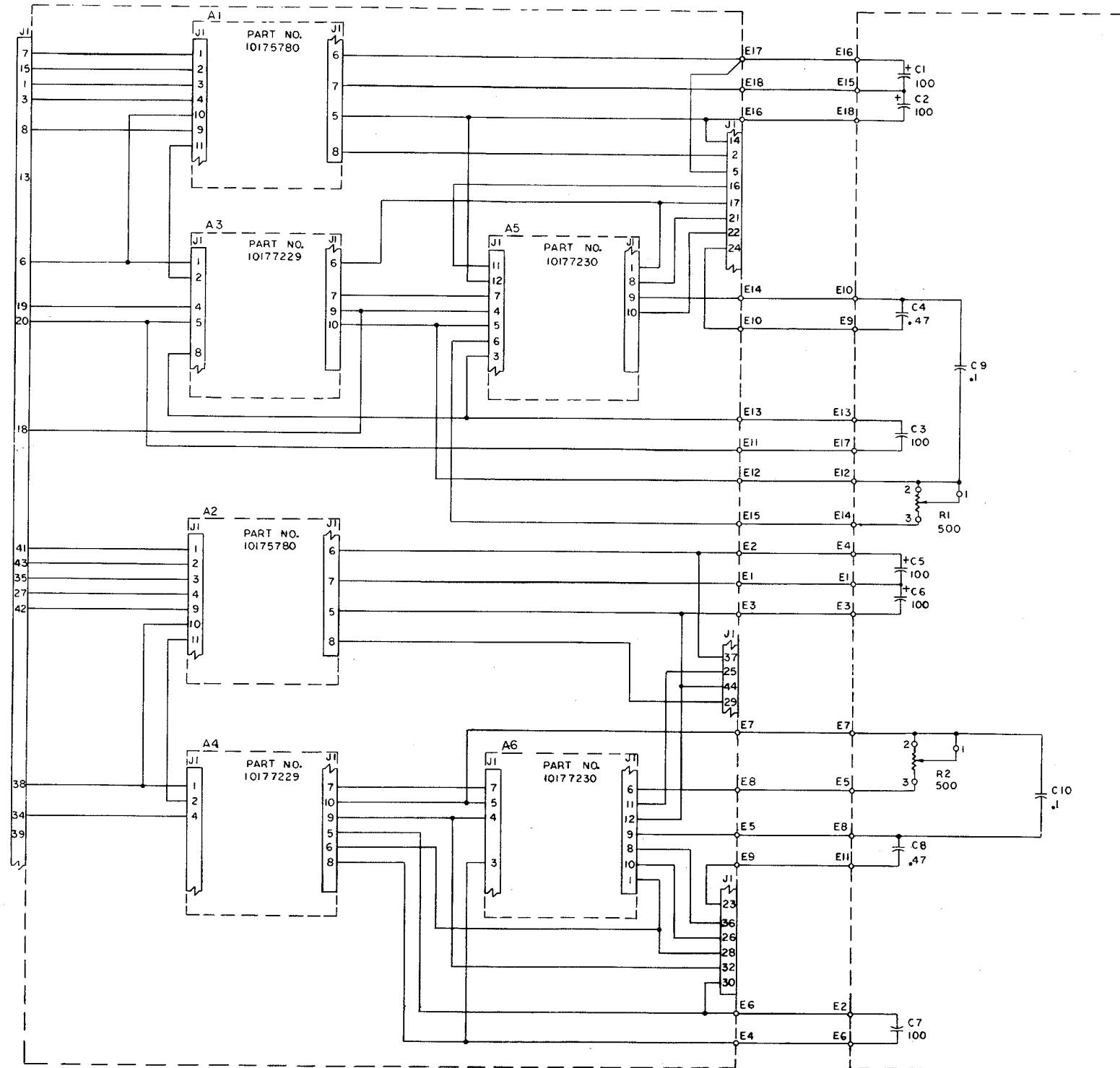

NOTE: REFER TO APPENDIX B FOR SERIAL NUMBER EFFECTIVITY.

MS 313464

Figure 2-28. Power supply subassembly (A1) 10176670 (FG 4275) * (K) (see note) schematic.

CHAPTER 3

SHOP AND CONSOLE ACCESSORIES SCHEMATICS

Section I. TEST LEADS AND CABLES

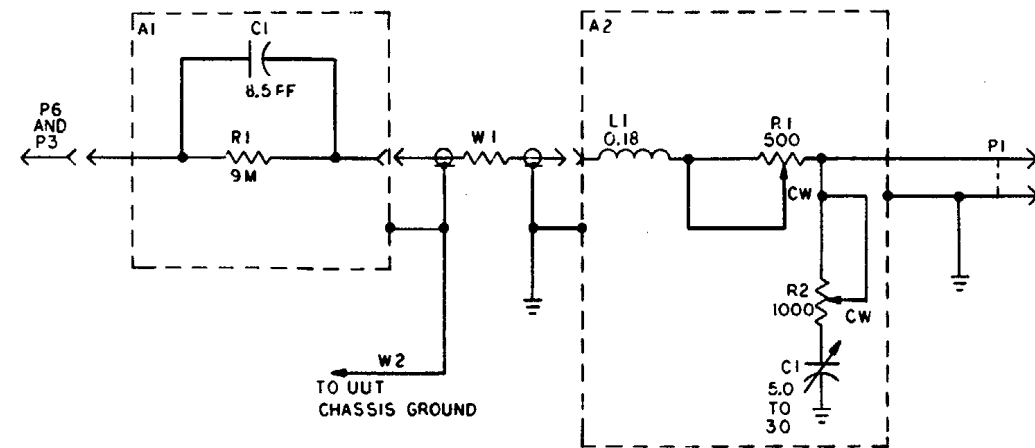

10:1 TEST PROBE SET 10672243

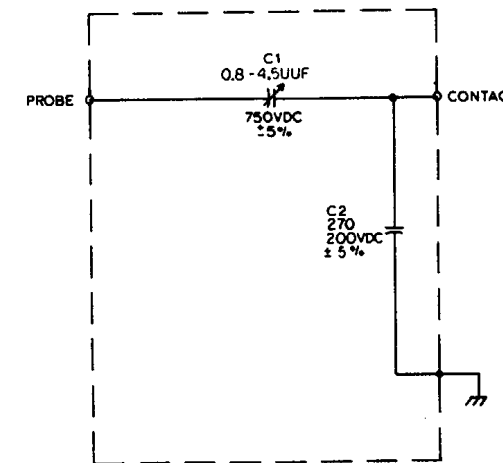

HI Z ATTENUATOR (100:1)
10183580

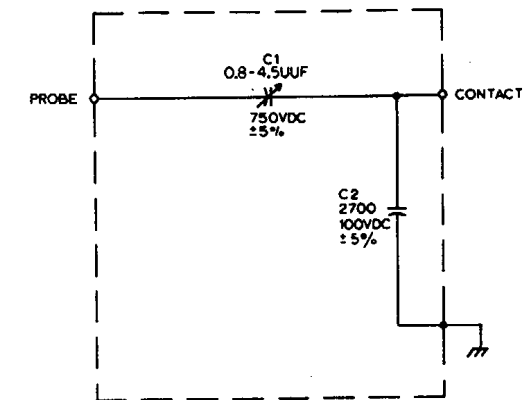

HI Z ATTENUATOR (1000:1)
10183581

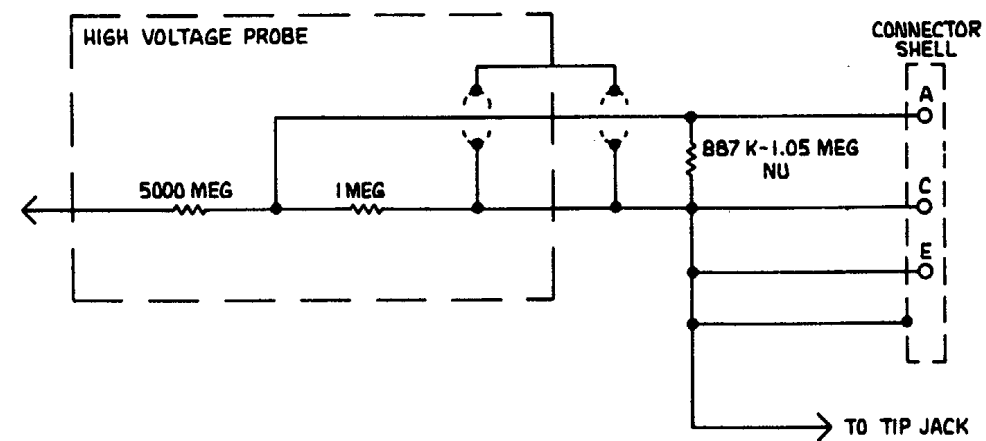

HIGH VOLTAGE PROBE (10,000:1)
10672247

MI 69899B

Figure 3-1. Test leads - schematic (sheet 1 of 3).

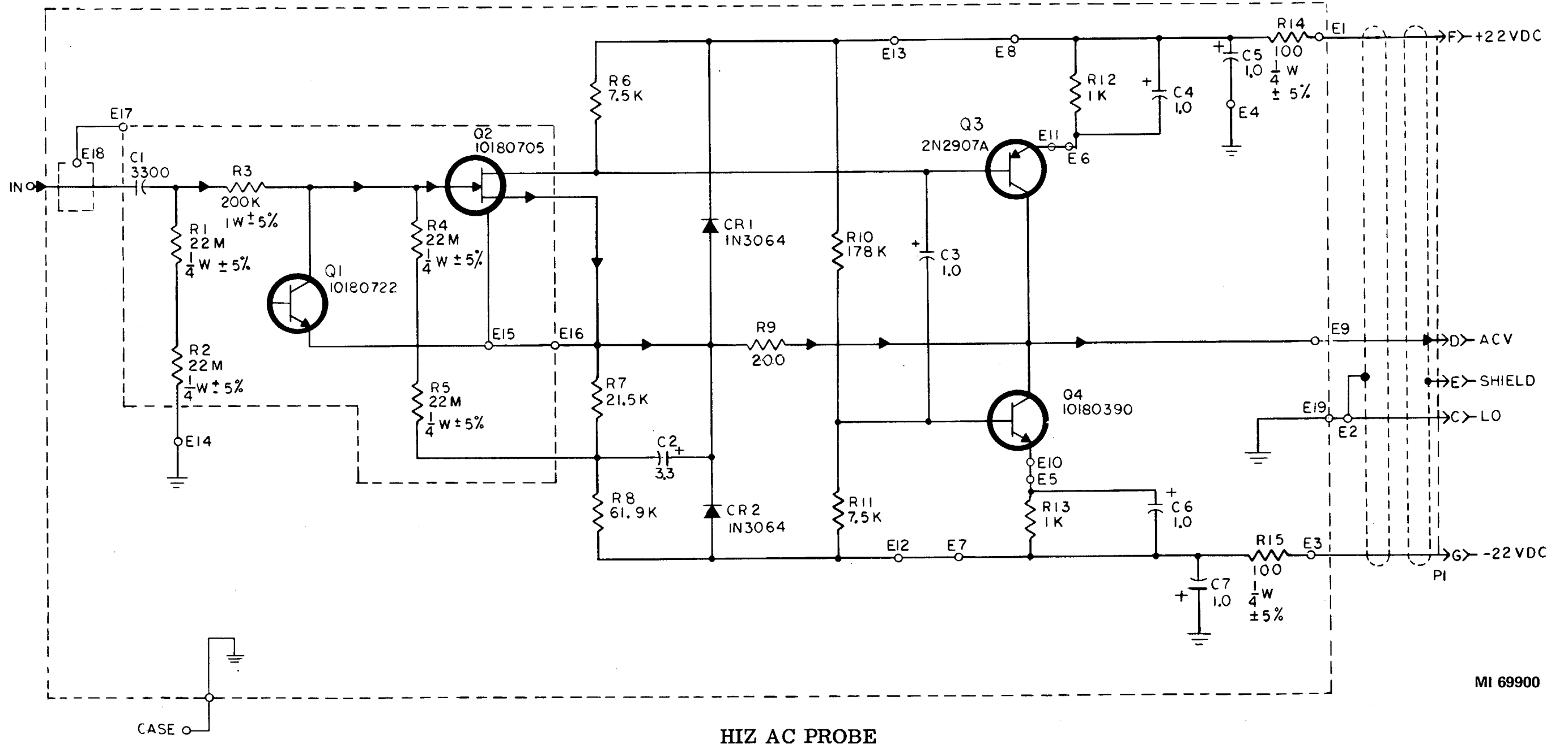

MI 69900

HIZ AC PROBE

Figure 3-1. Test leads - schematic (sheet 2 of 3).

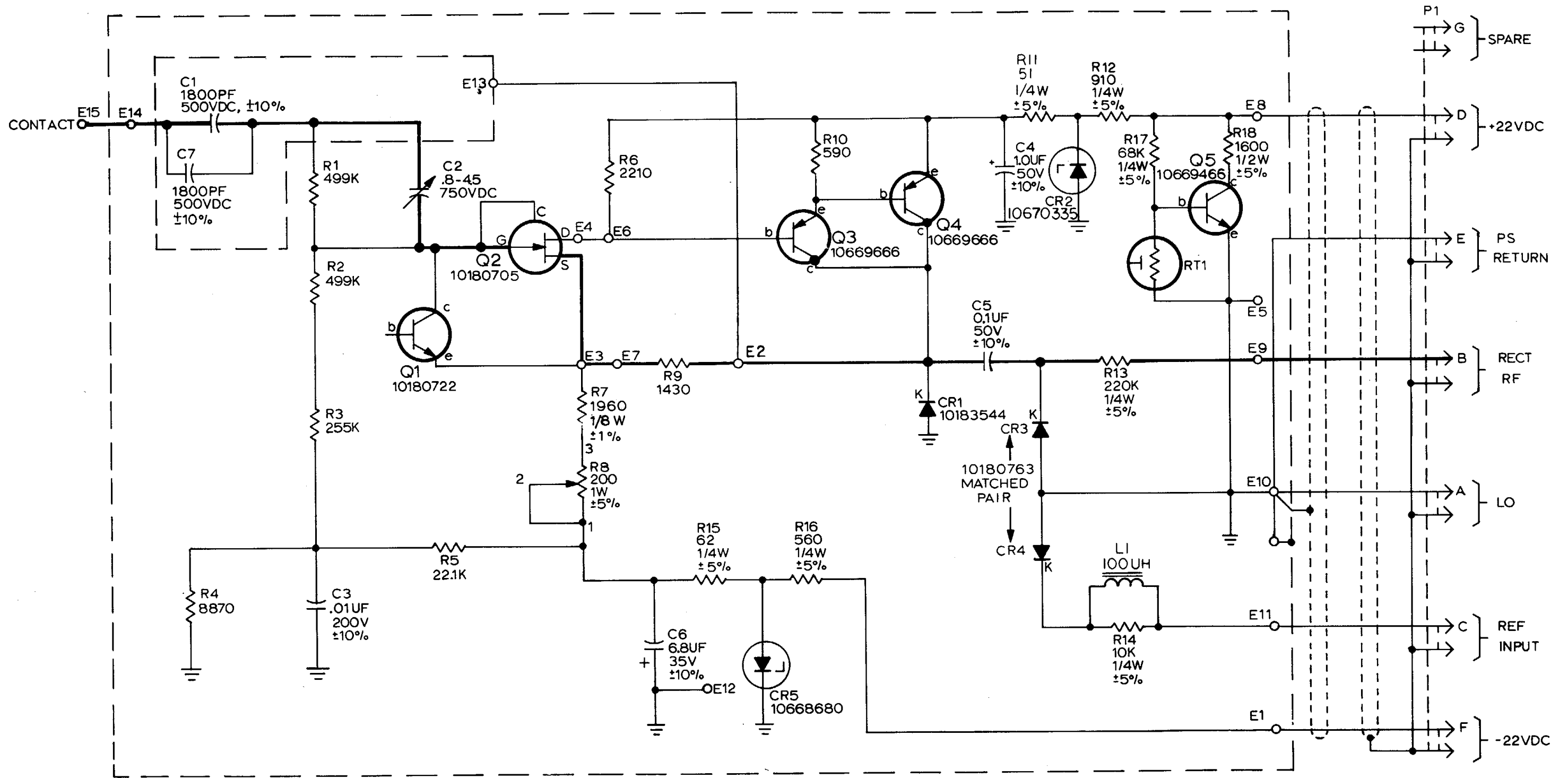

HIZ RF PROBE

MI 69901

Figure 3-1. Test leads - schematic (sheet 3 of 3).

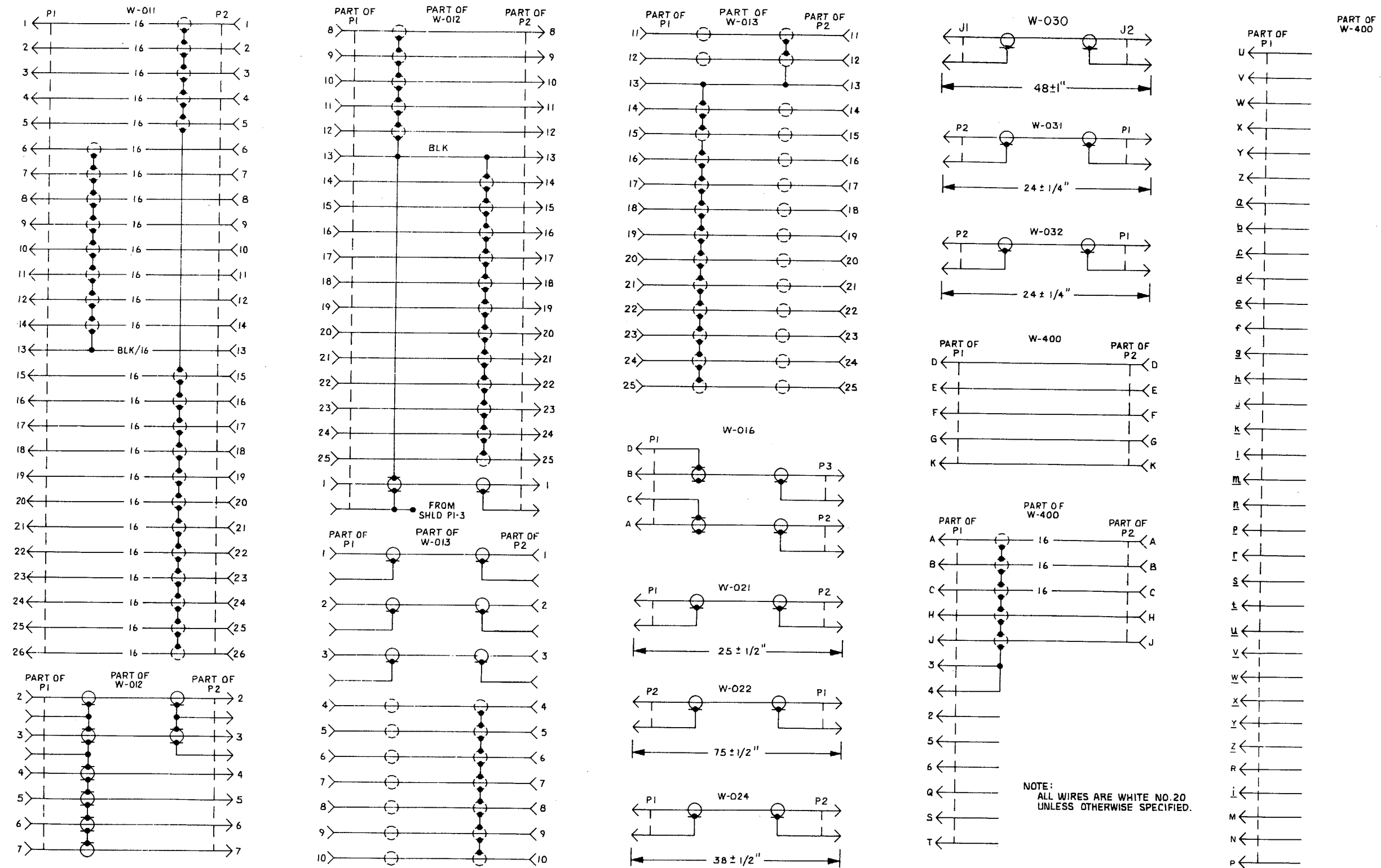

MI 69902A

Figure 3-2. Test cables - schematic (sheet 1 of 25).

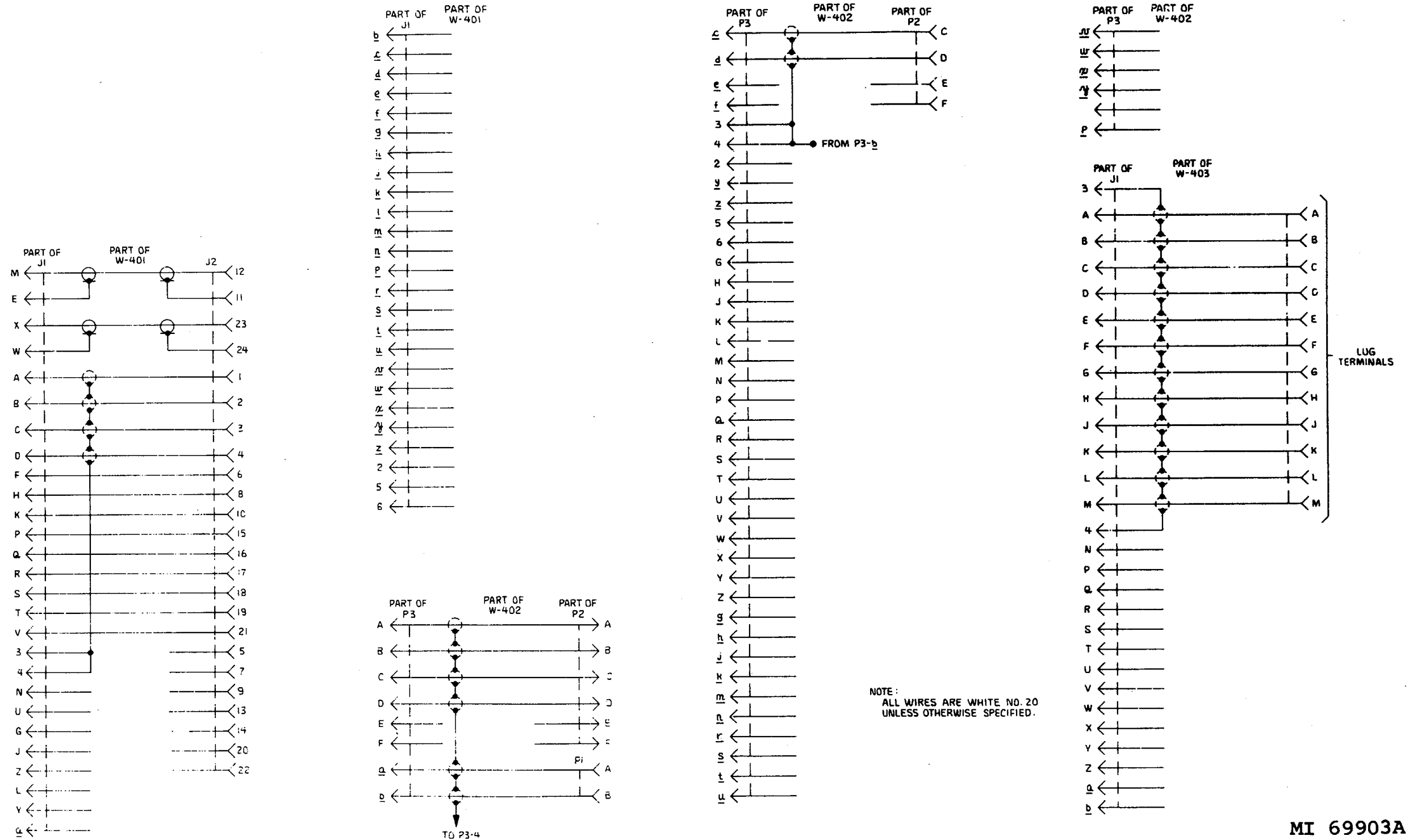

Figure 3-2. Test cables - schematic (sheet 2 of 25).

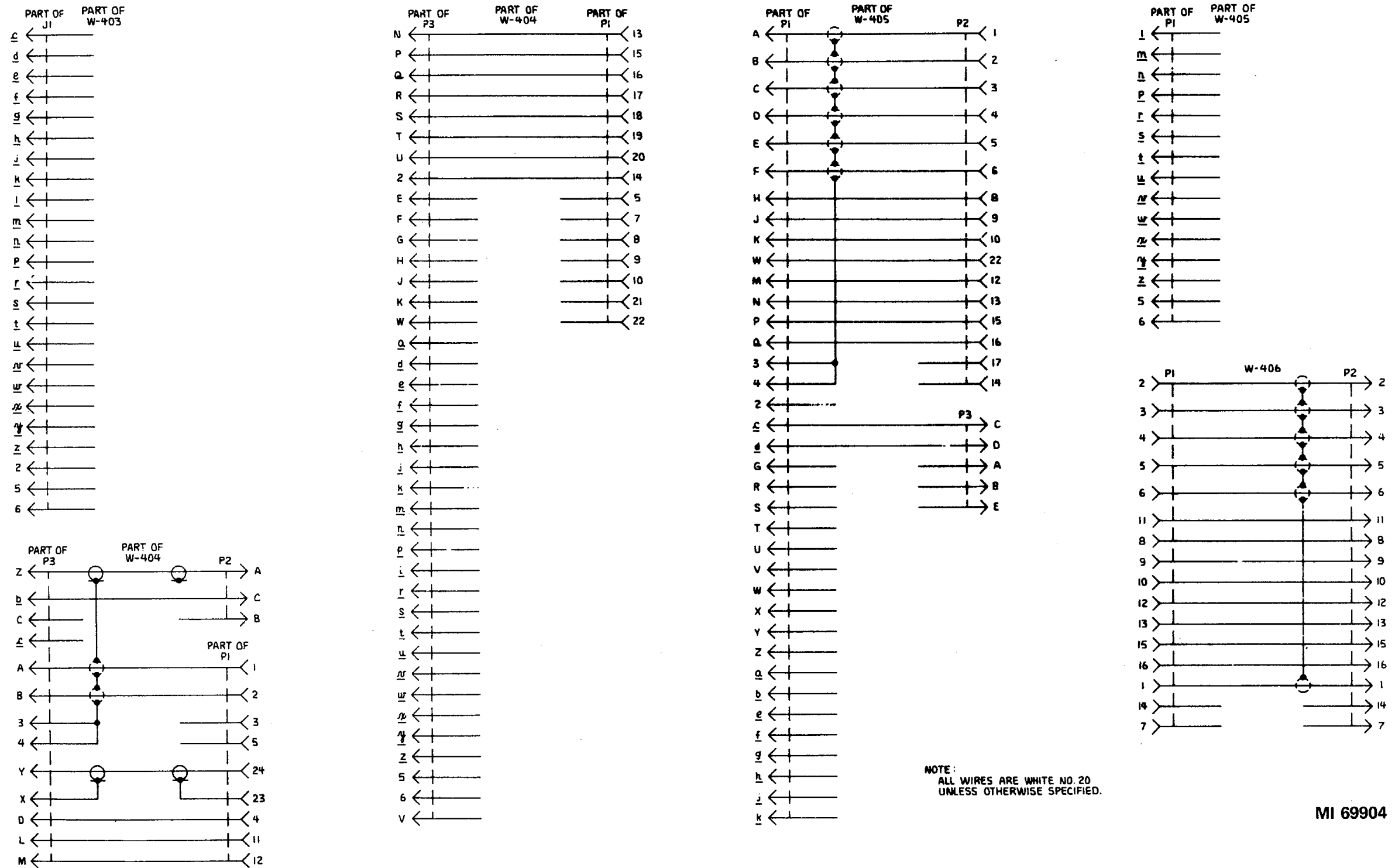

Figure 3-2. Test cables - schematic (sheet 3 of 25).

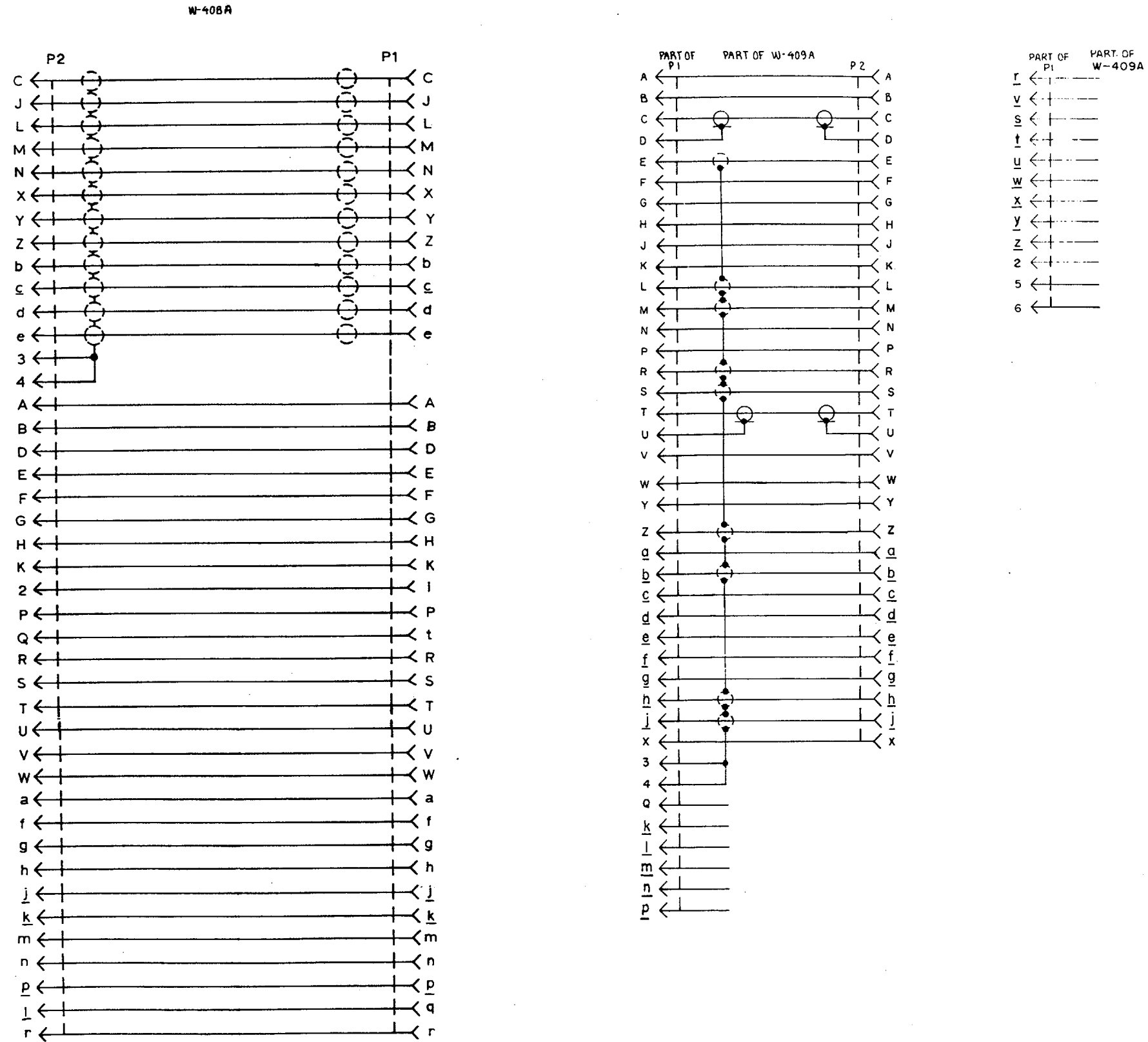
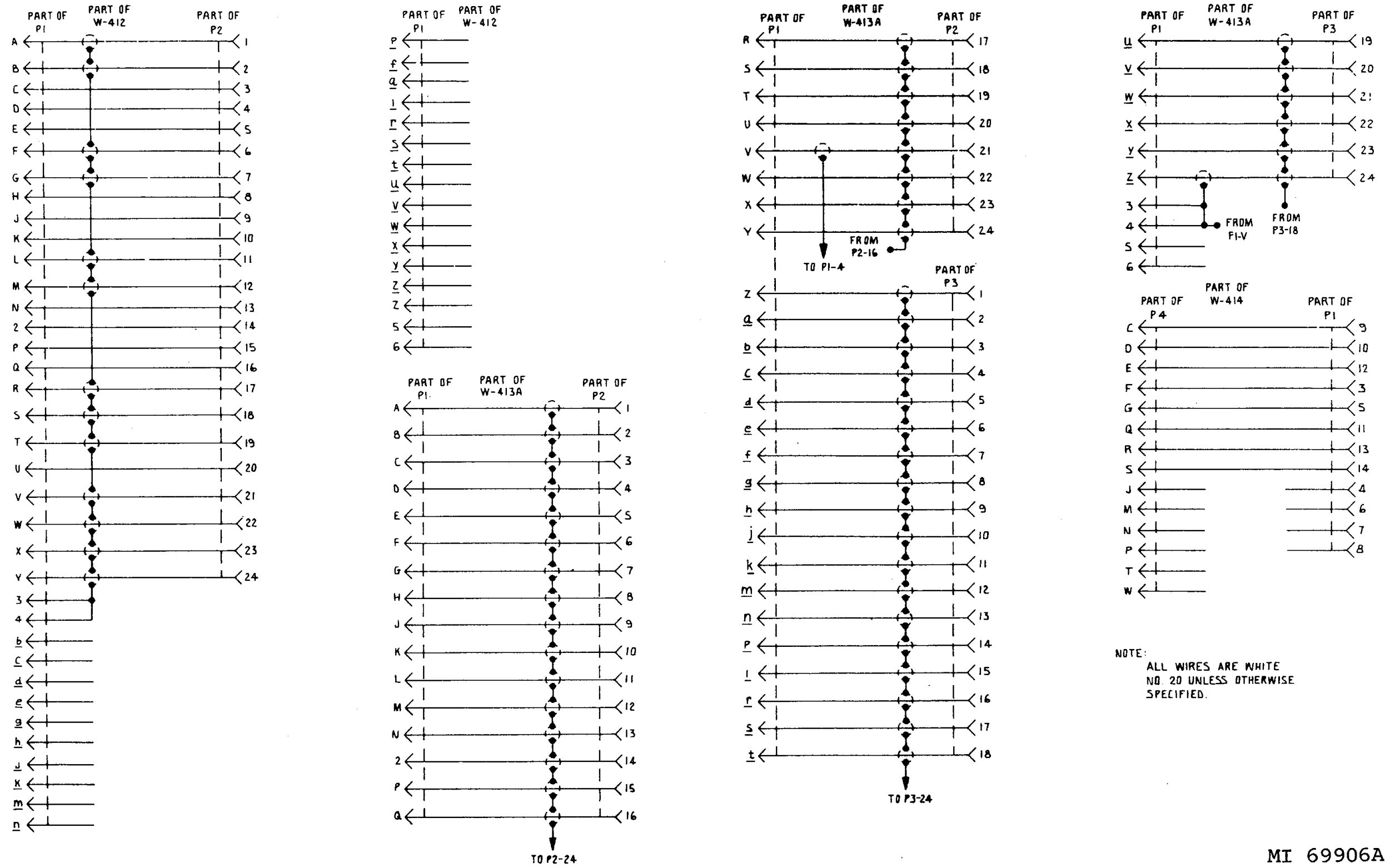

Figure 3-2. Test cables - schematic (sheet 4 of 25).

MS 309256



NOTE:
ALL WIRES ARE WHITE
NO. 20 UNLESS OTHERWISE
SPECIFIED.

MI 69906A

Figure 3-2. Test cables - schematic (sheet 5 of 25).

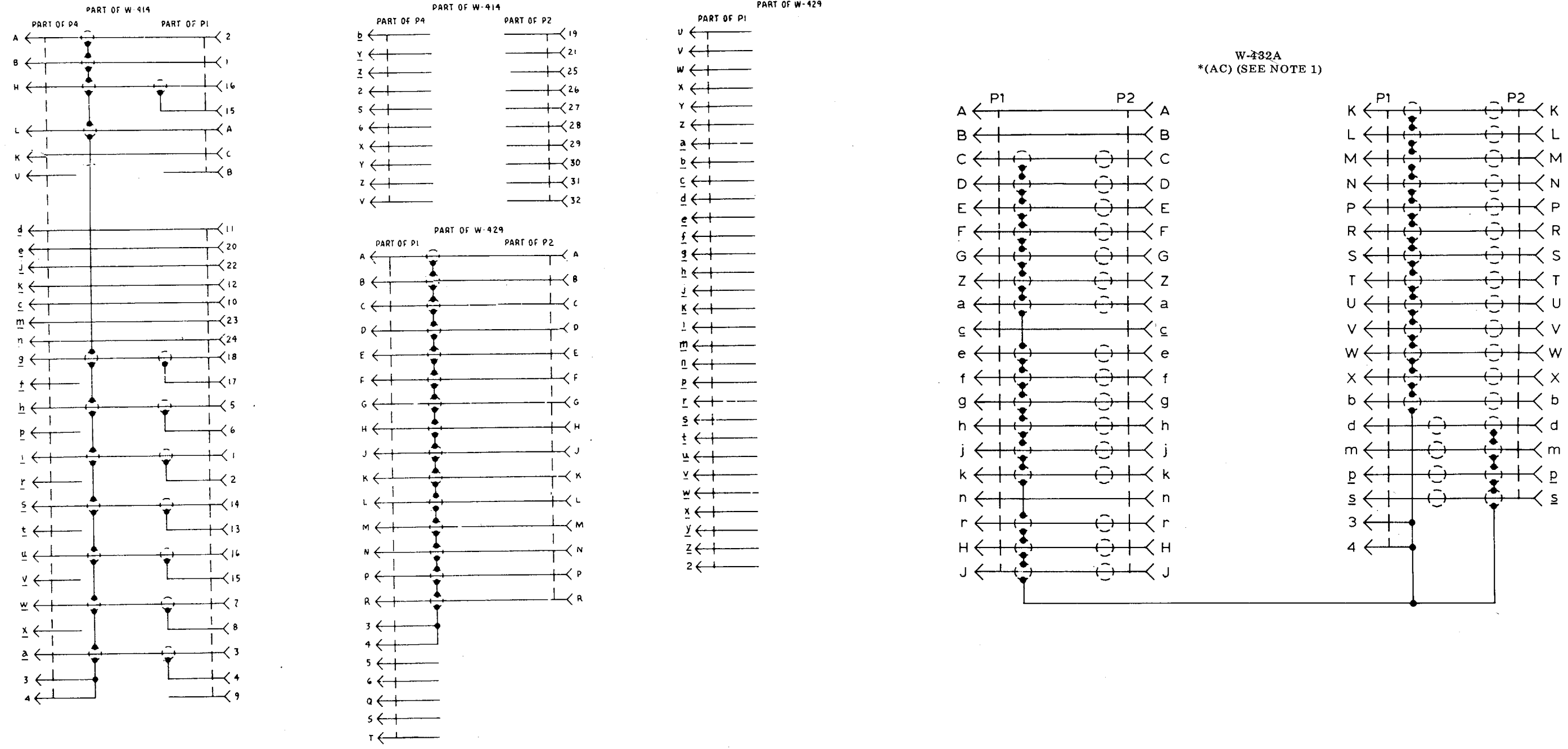

- NOTES:
1. REFER TO APPENDIX B FOR SERIAL NUMBER EFFECTIVITY
 2. ALL WIRES ARE WHITE NO. 20 UNLESS OTHERWISE SPECIFIED

MI 69907B

Figure 3-2. Test cables - schematic (sheet 6 of 25).

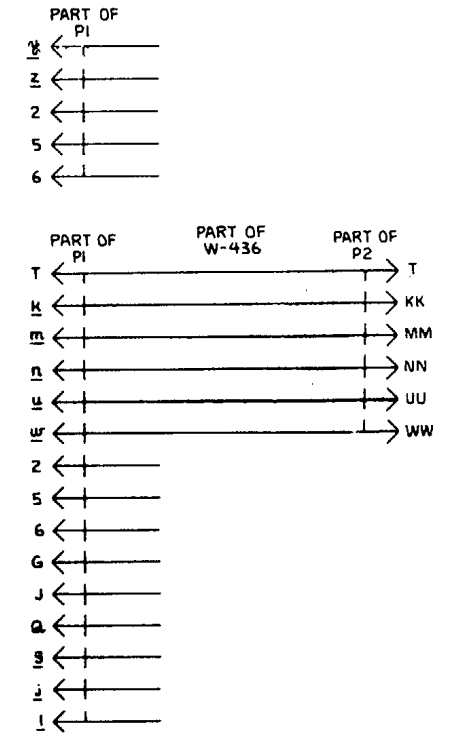
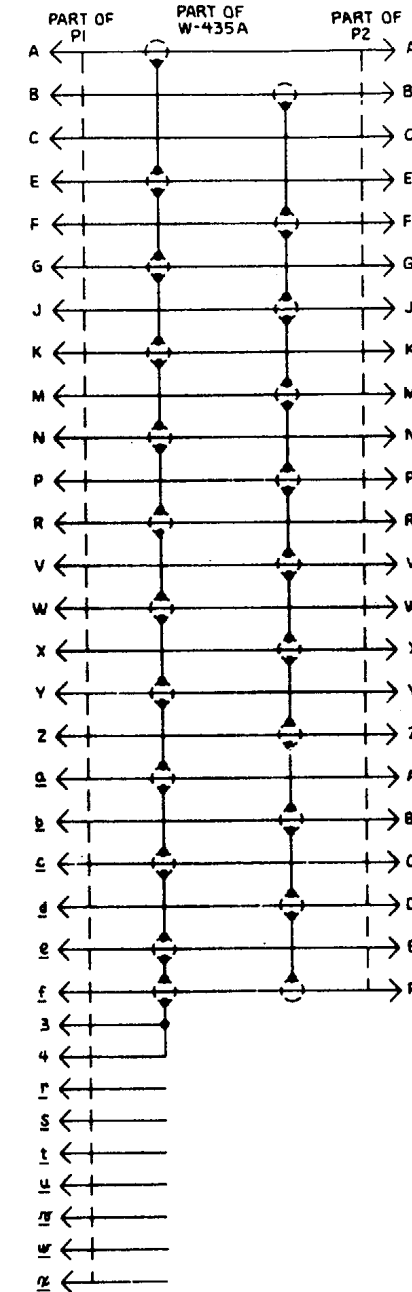
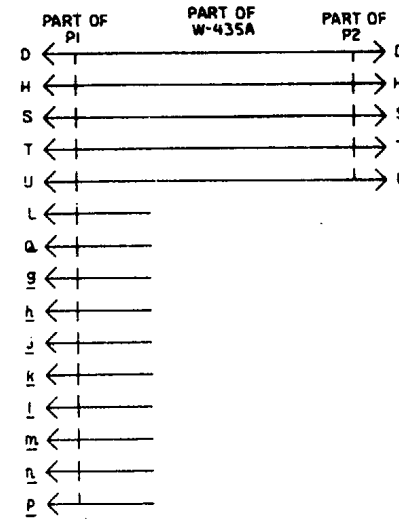
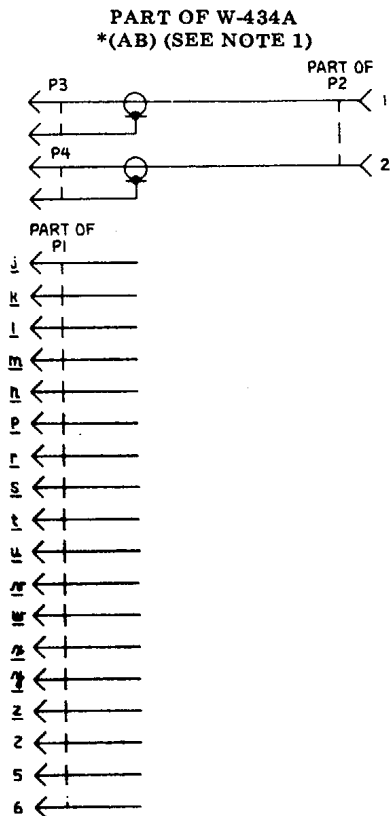
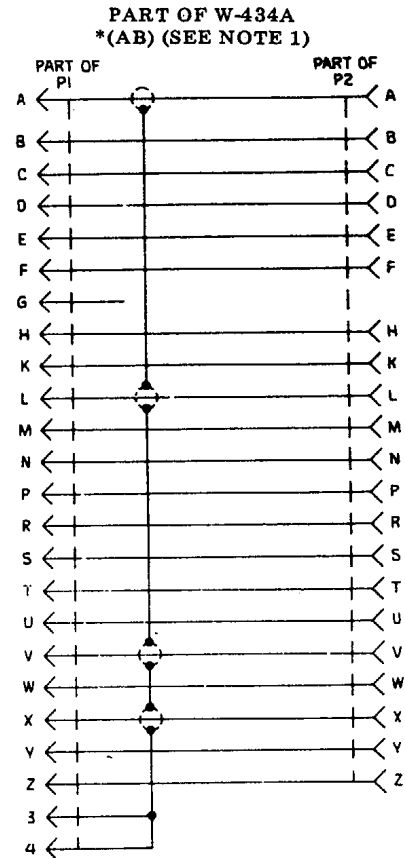
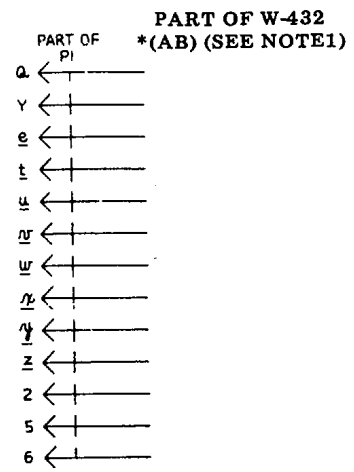
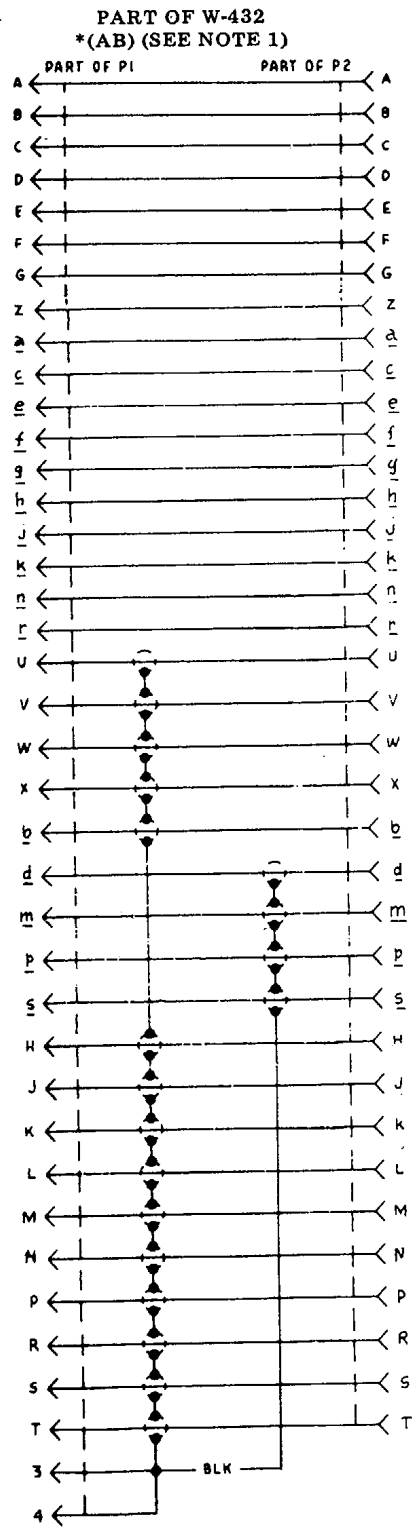

- NOTES:
1. REFER TO APPENDIX B FOR SERIAL NUMBER EFFECTIVITY
 2. ALL WIRES ARE WHITE NO. 20 UNLESS OTHERWISE SPECIFIED

MI 69908A

Figure 3-2. Test cables - schematic (sheet 7 of 25).

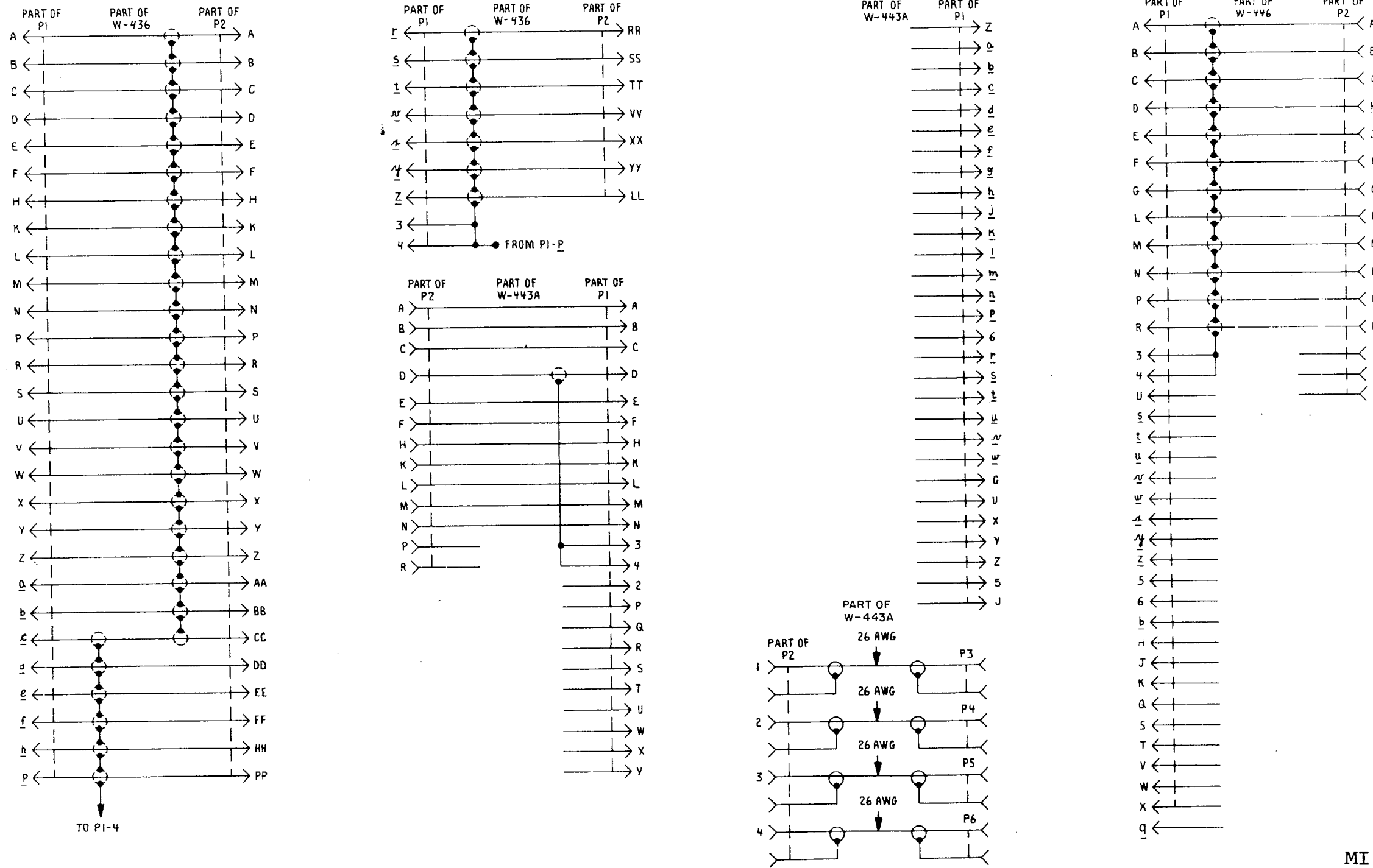

Figure 3-2. Test cables - schematic (sheet 8 of 25)

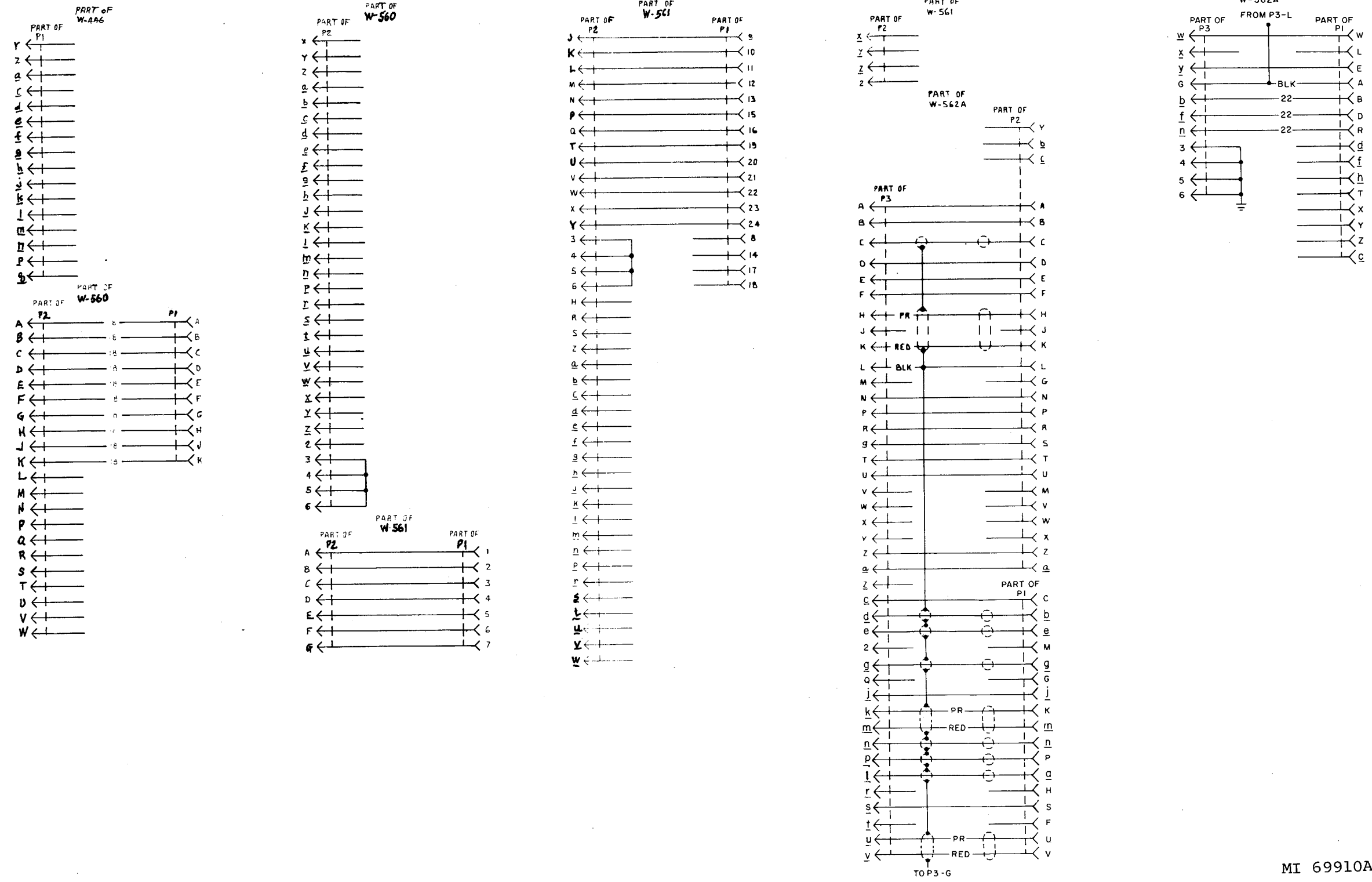
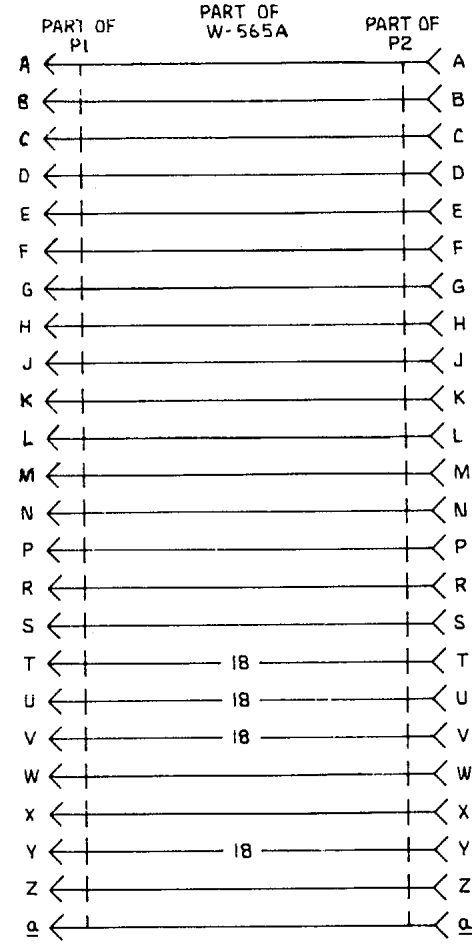
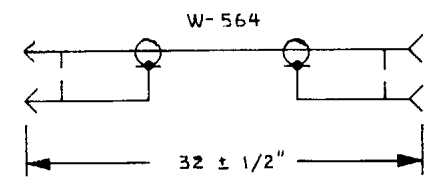
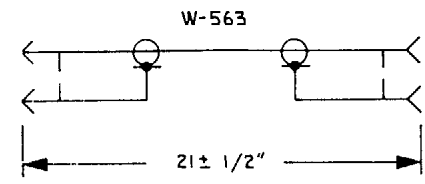
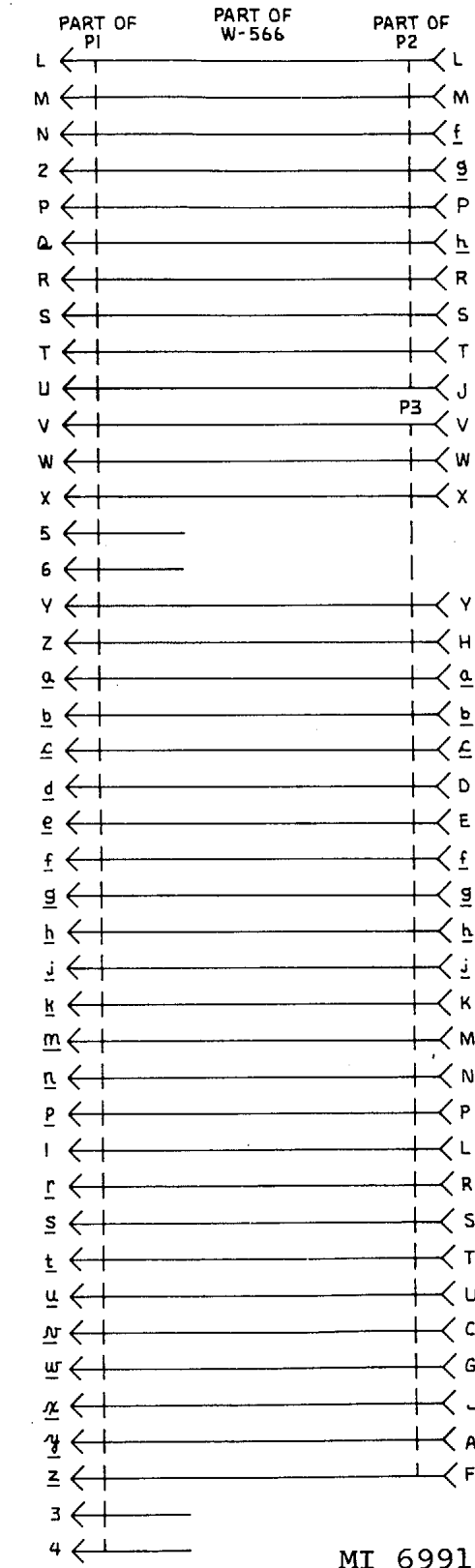
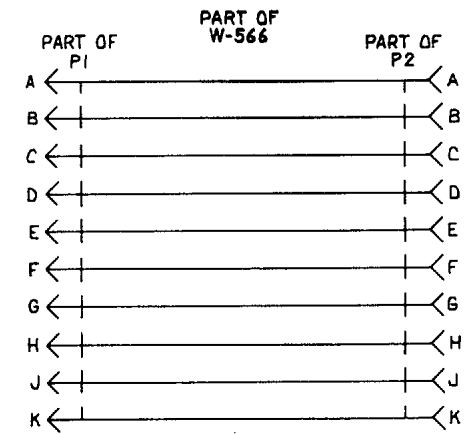
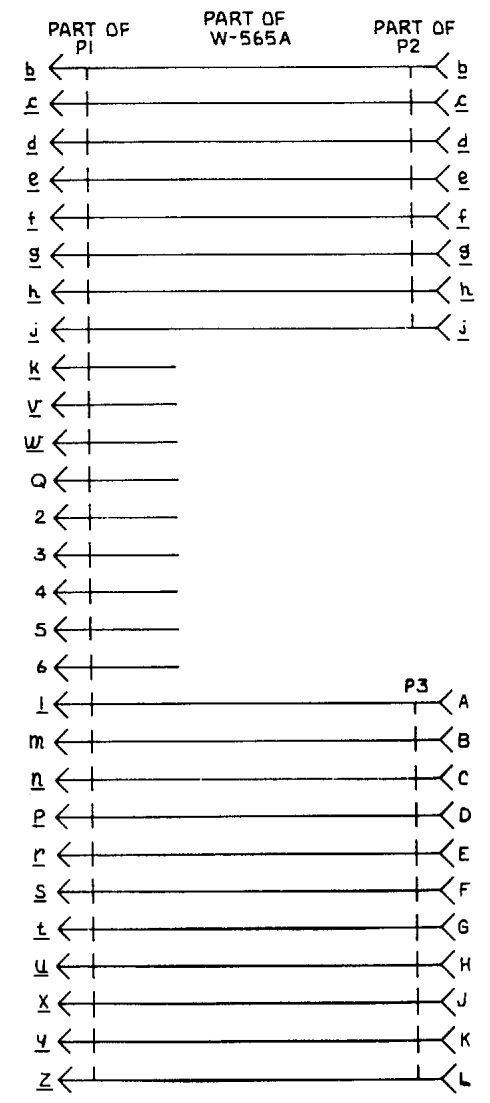

Figure 3-2. Test cables - schematic (sheet 9 of 25)

MI 69910A



NOTE:
ALL WIRES ARE WHITE NO.20
UNLESS OTHERWISE SPECIFIED.



MI 69911A

Figure 3-2. Test cables - schematic (sheet 10 of 25)

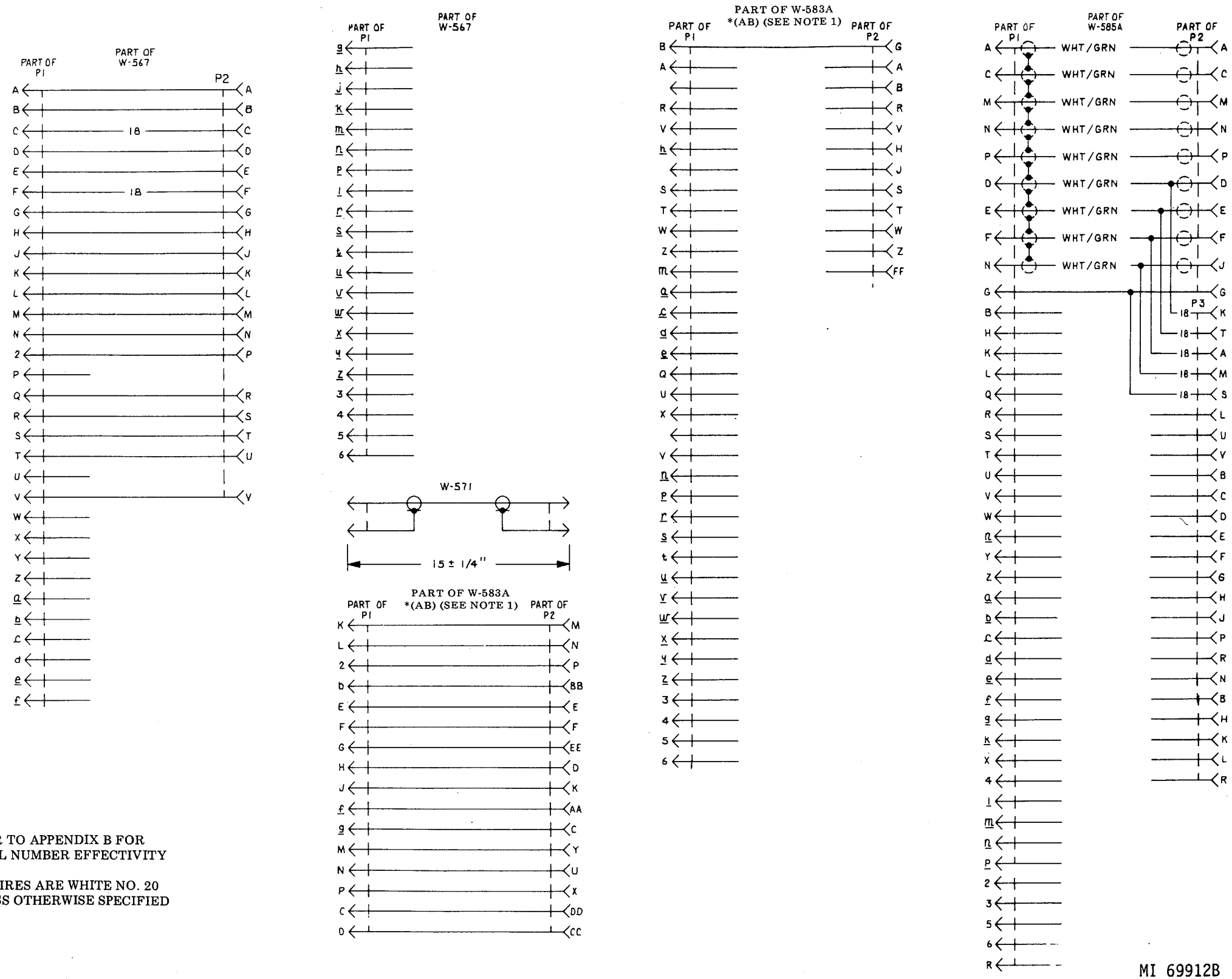

- NOTES:
1. REFER TO APPENDIX B FOR SERIAL NUMBER EFFECTIVITY
 2. ALL WIRES ARE WHITE NO. 20 UNLESS OTHERWISE SPECIFIED

Figure 3-2. Test cables - schematic (sheet 11 of 25)

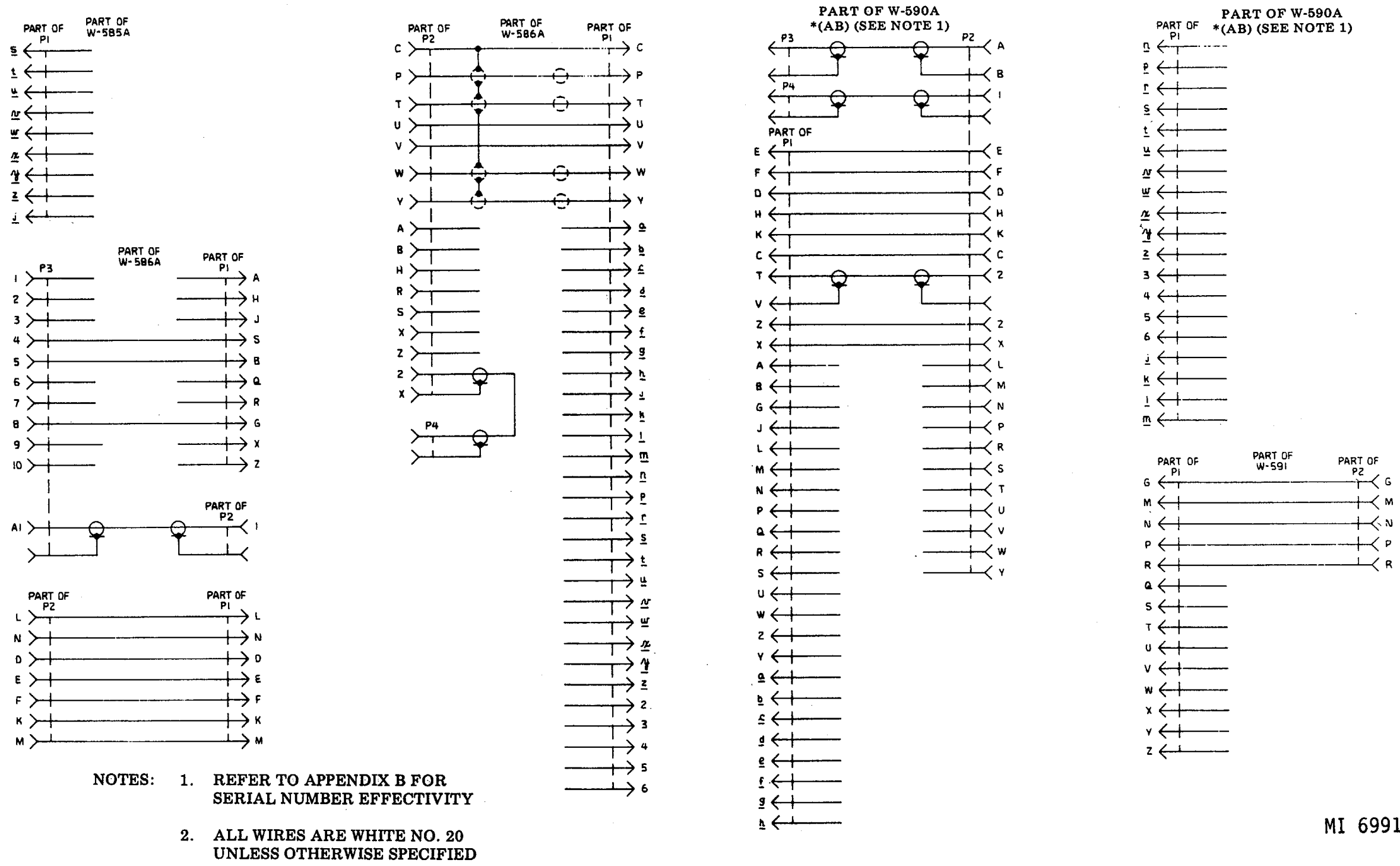

Figure 3-2. Test cables - schematic (sheet 12 of 25)

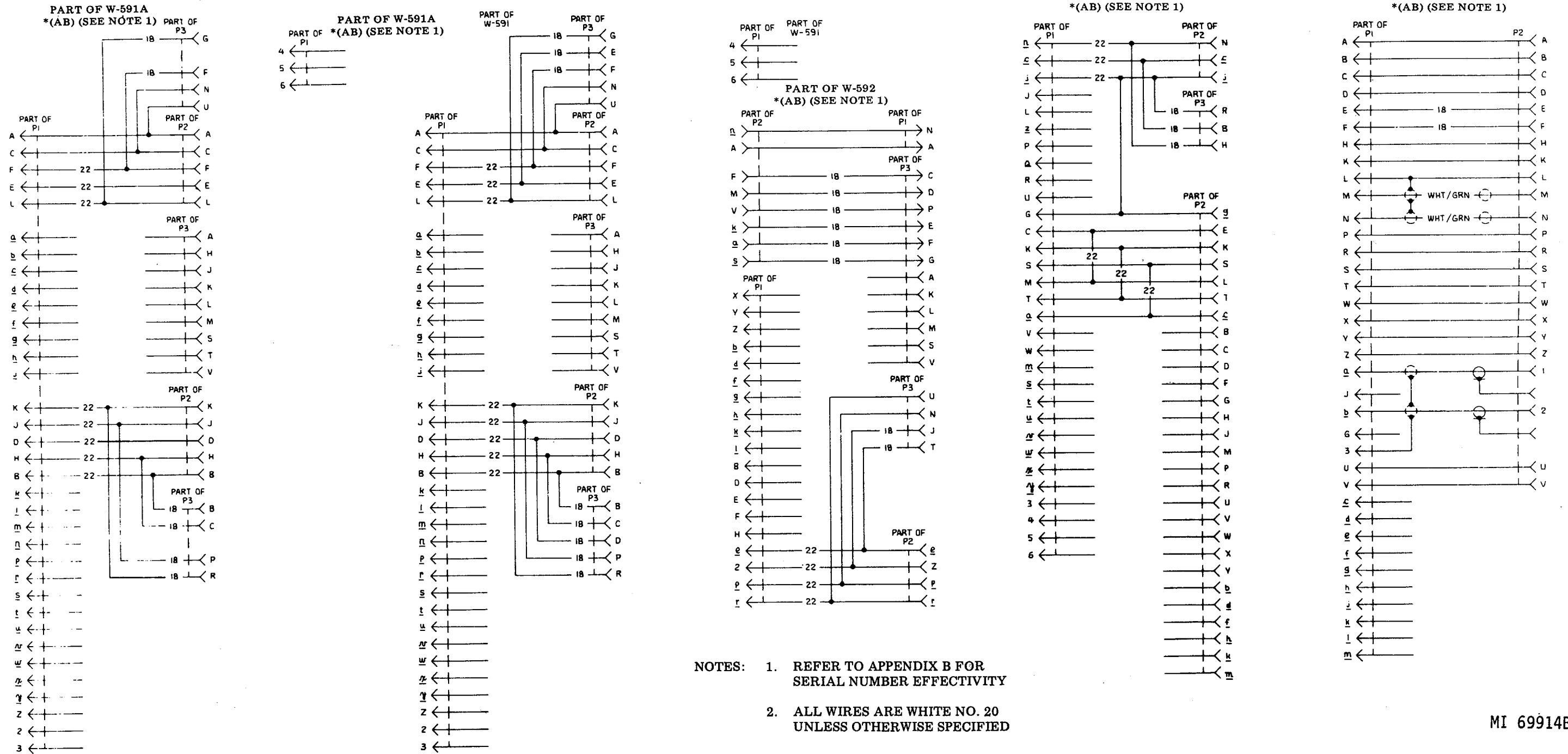
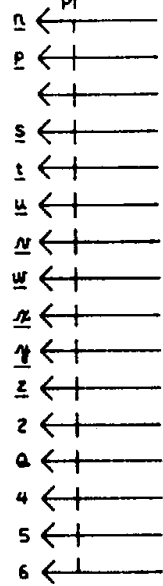
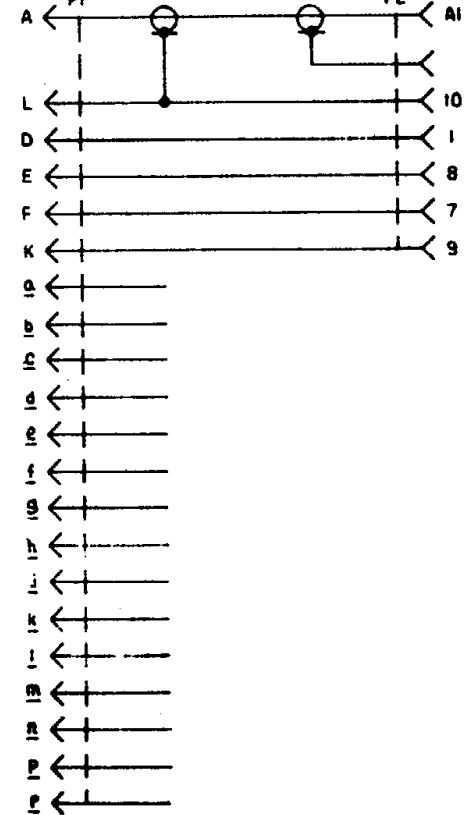

Figure 3-2. Test cables - schematic (sheet 13 of 25)

PART OF W-593A
PART OF *(AB) (SEE NOTE 1)



PART OF W-595
PART OF *(AB) (SEE NOTE 1)



PART OF W-595
PART OF *(AB) (SEE NOTE 1)

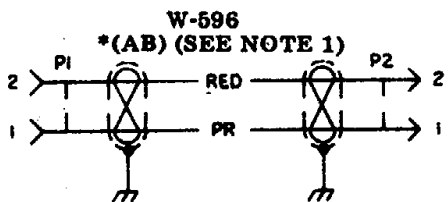
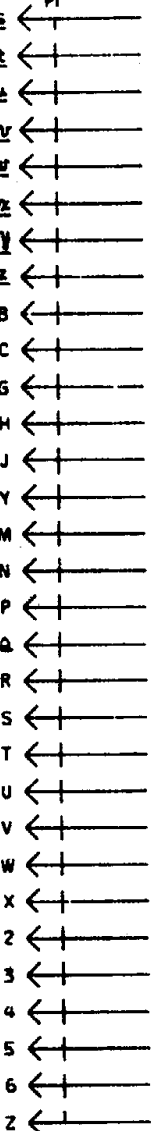

PART OF W-599
PART OF *(AB) (SEE NOTE 1)

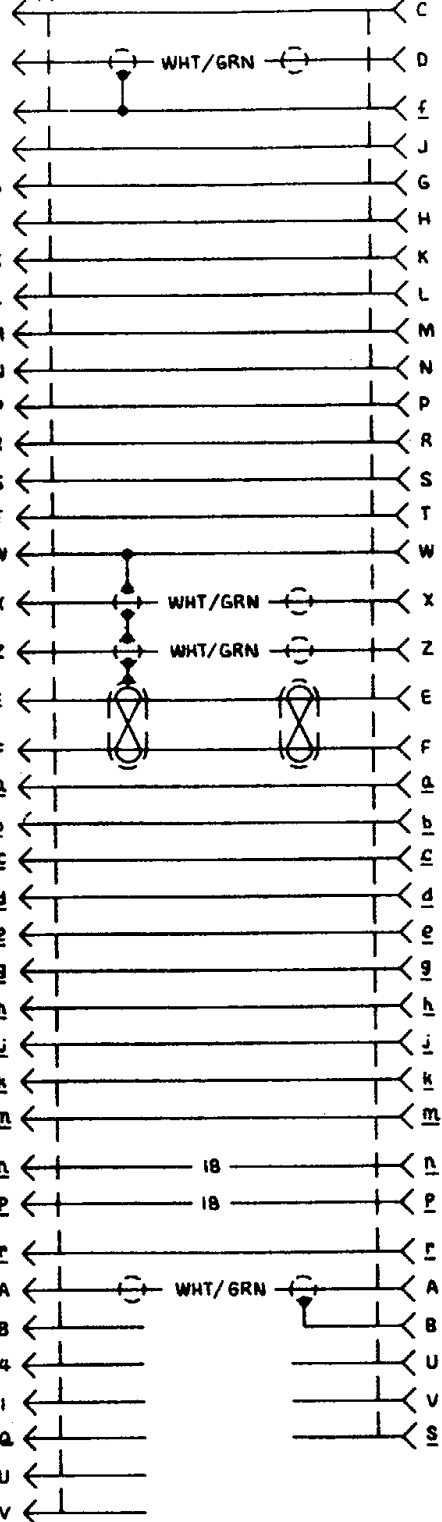

PART OF W-599
PART OF *(AB) (SEE NOTE 1)

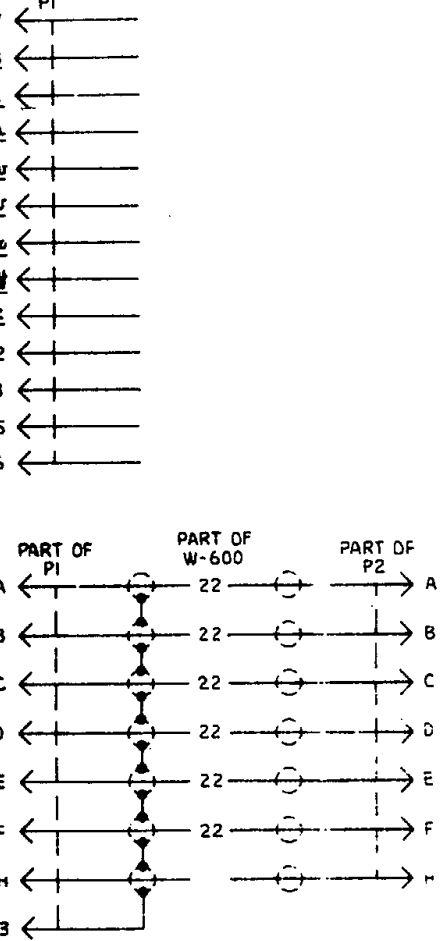

- NOTES: 1. REFER TO APPENDIX B FOR SERIAL NUMBER EFFECTIVITY
2. ALL WIRES ARE WHITE NO. 20 UNLESS OTHERWISE SPECIFIED

MI 69915A

Figure 3-2. Test cables - schematic (sheet 14 of 25)

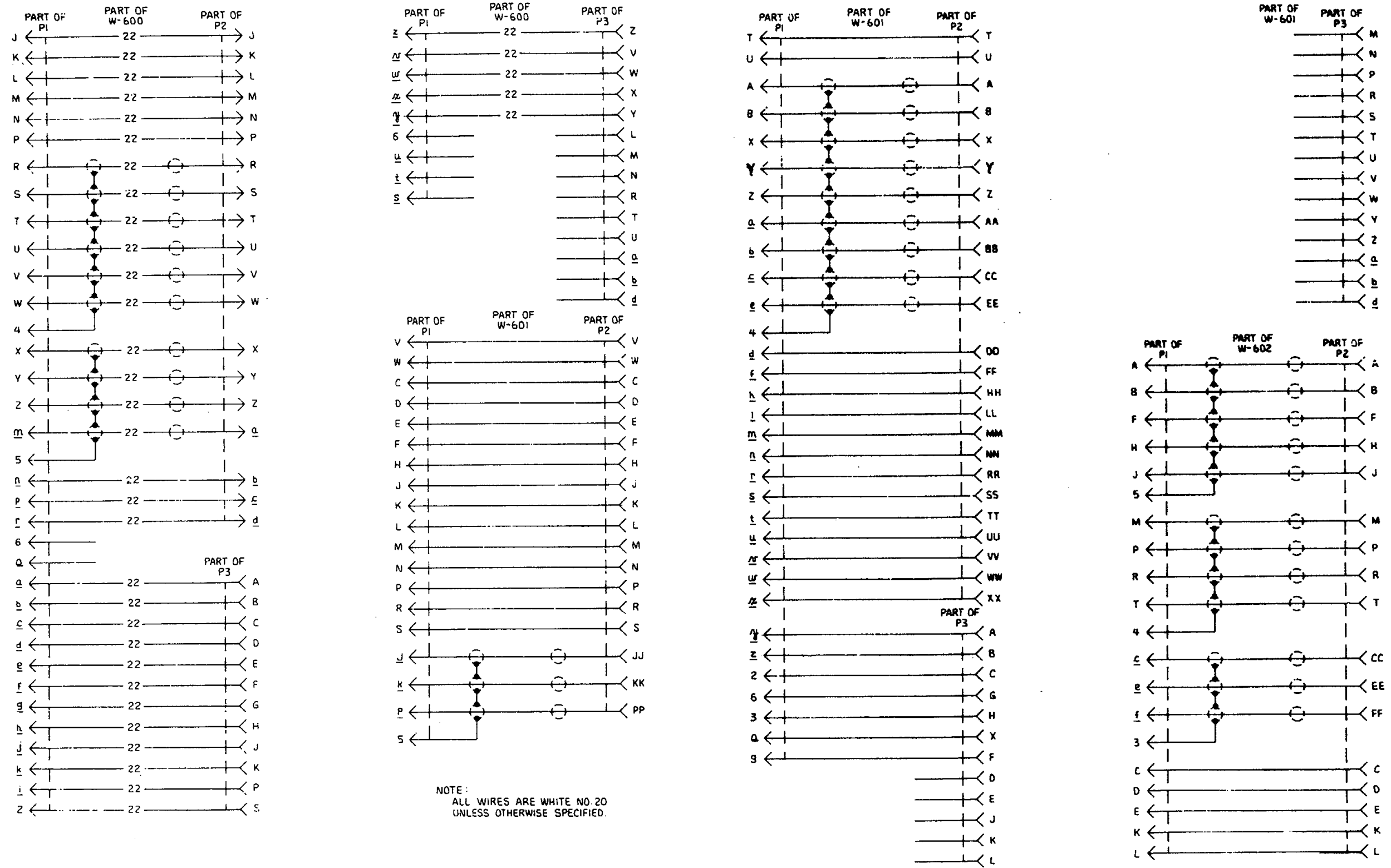

Figure 3-2. Test cables - schematic (sheet 15 of 25)

MI 69916

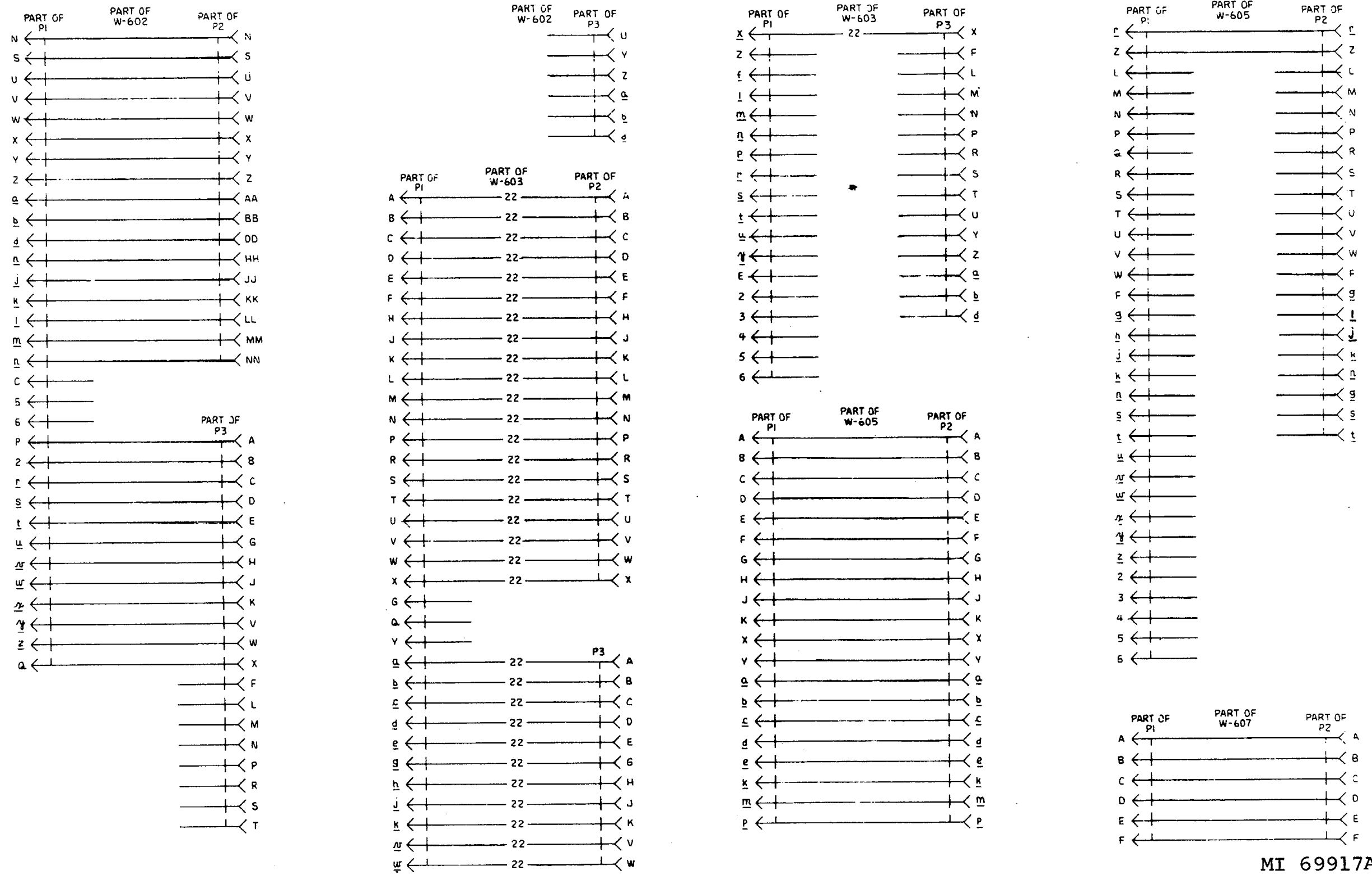

Figure 3-2. Test cables - schematic (sheet 16 of 25)

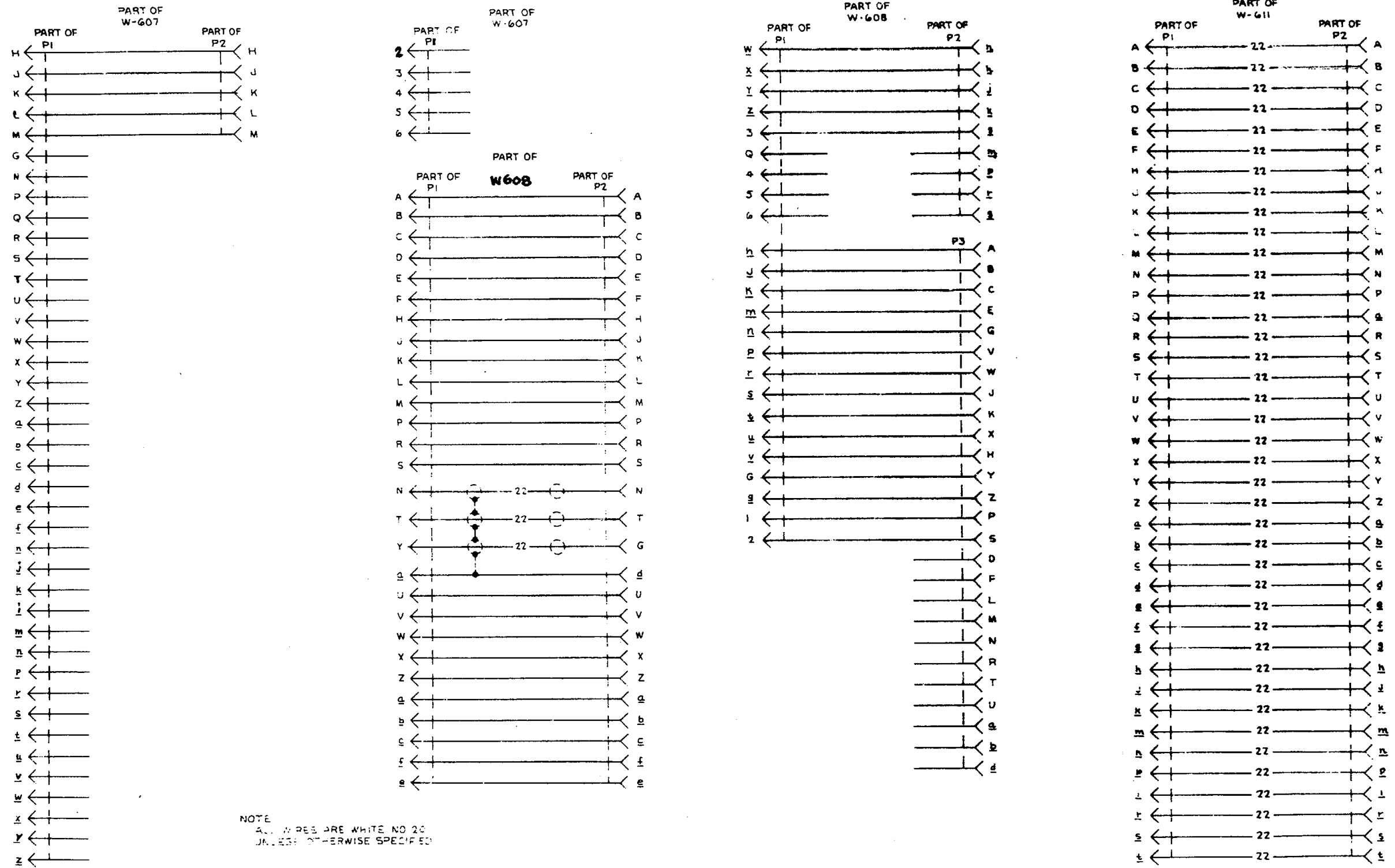
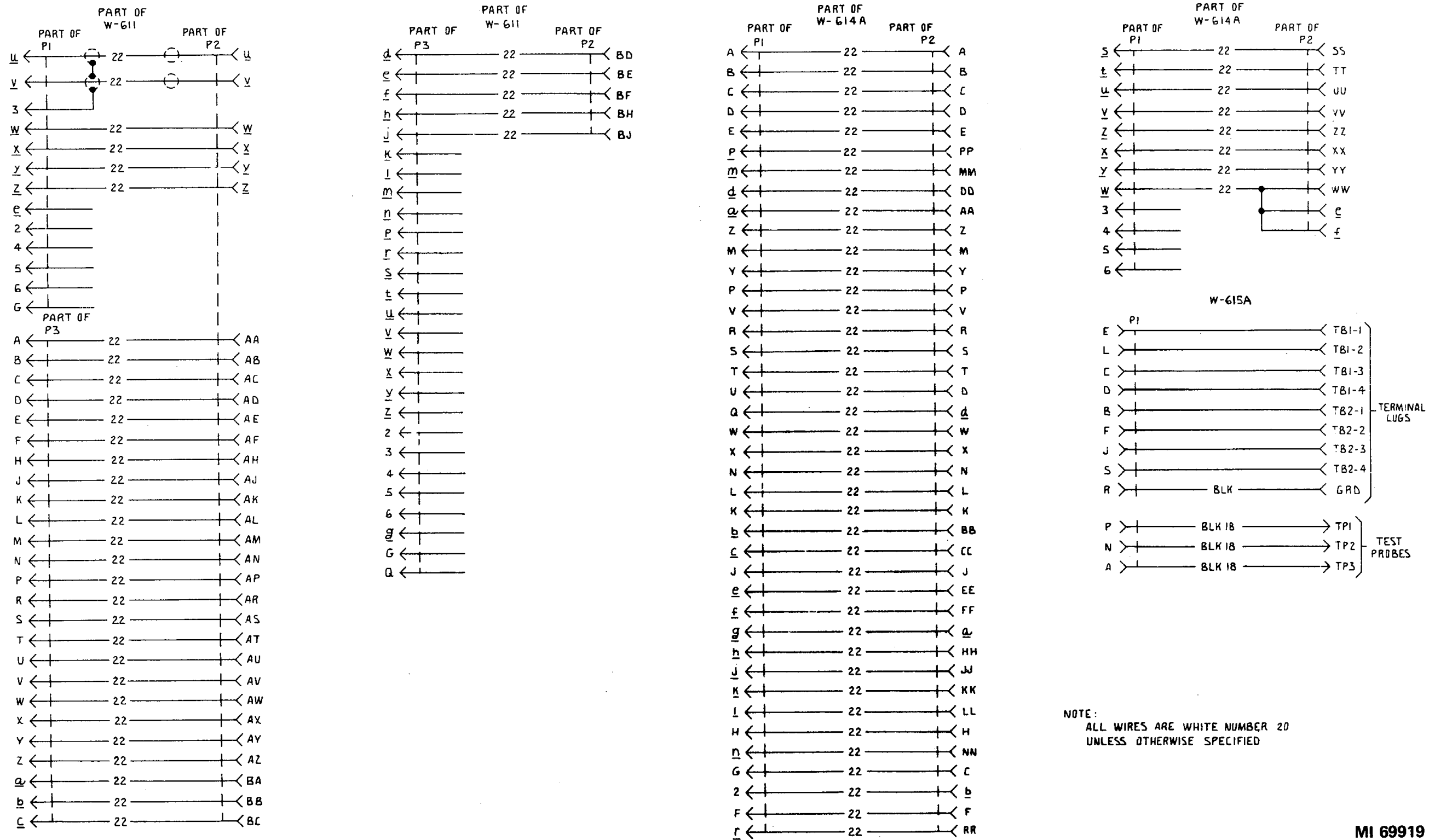

Figure 3-2. Test cables - schematic (sheet 17 of 25)

MI 69918



NOTE:
ALL WIRES ARE WHITE NUMBER 20
UNLESS OTHERWISE SPECIFIED

MI 69919

Figure 3-2. Test cables - schematic (sheet 18 of 25)

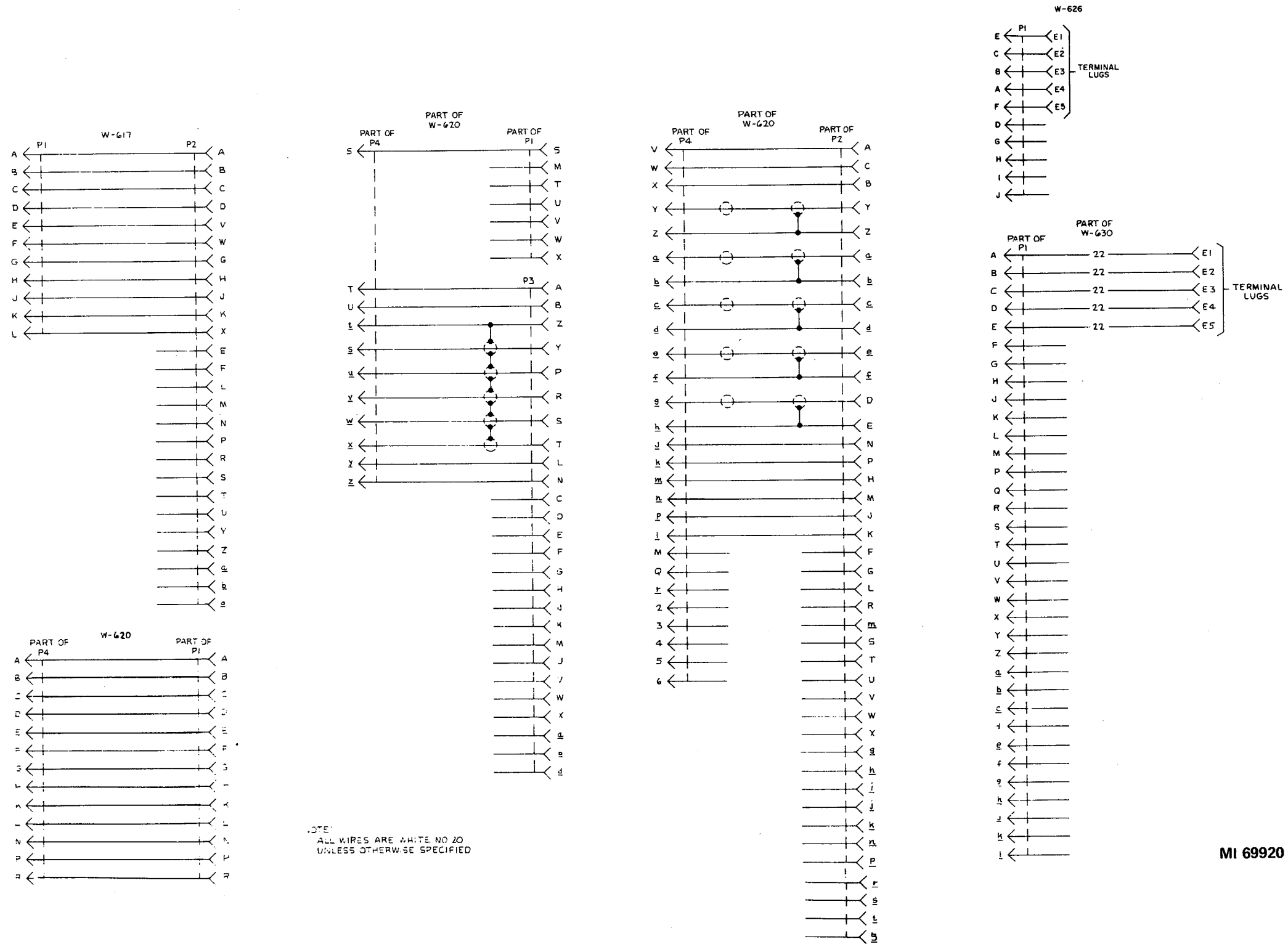
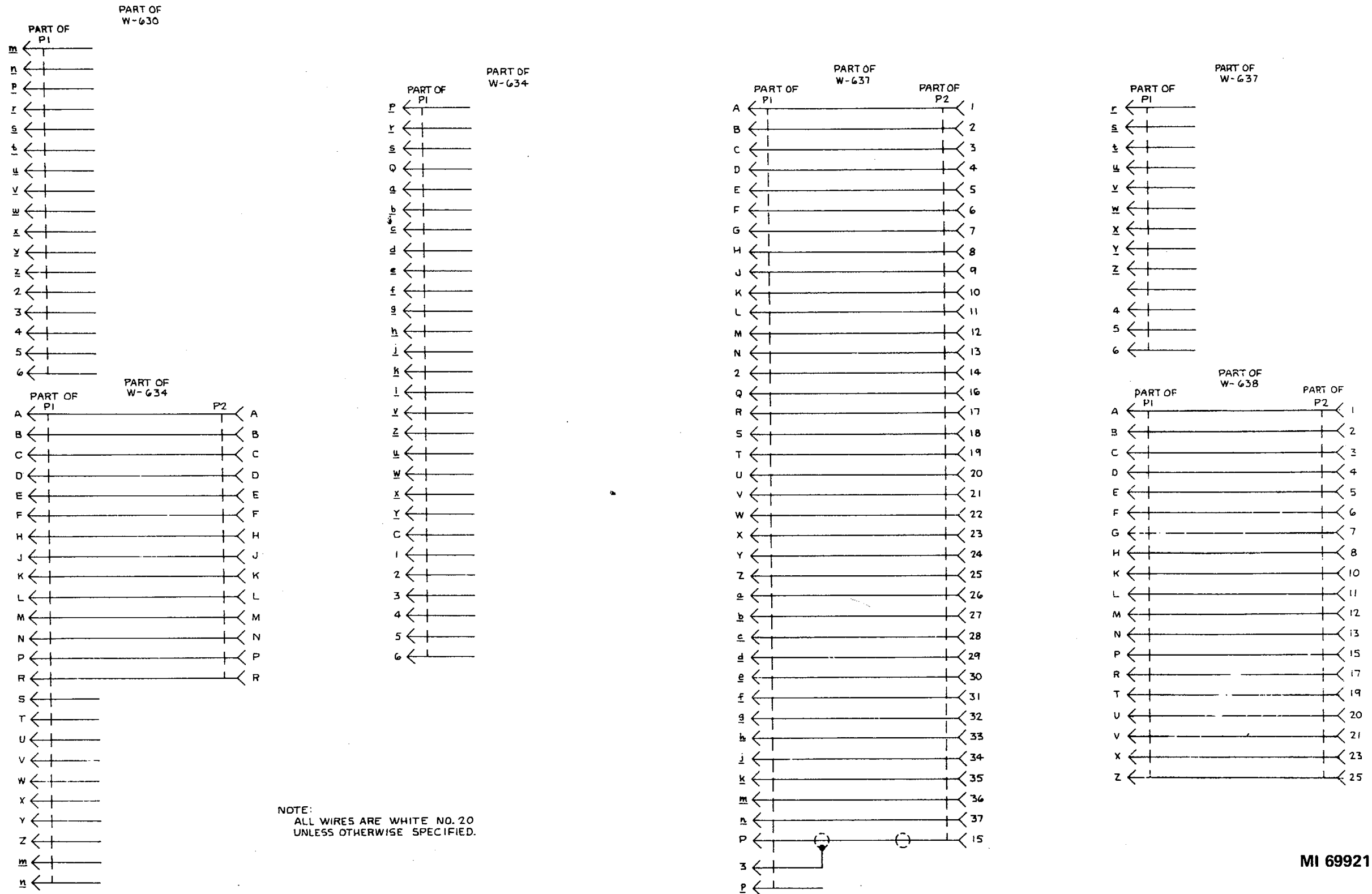
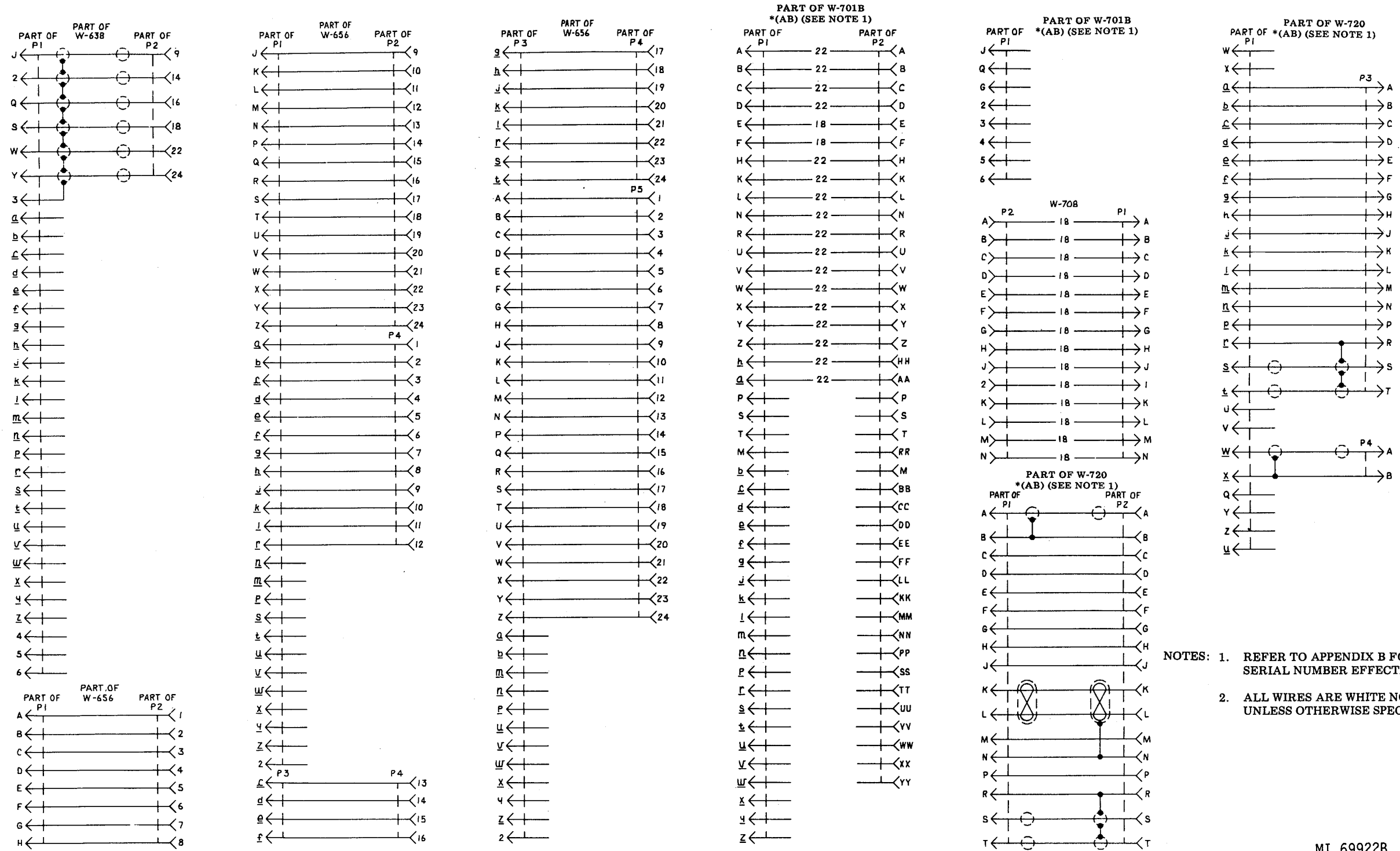

Figure 3-2. Test cables - schematic (sheet 19 of 25)



MI 69921

Figure 3-2. Test cables - schematic (sheet 20 of 25)



NOTES: 1. REFER TO APPENDIX B FOR SERIAL NUMBER EFFECTIVITY
2. ALL WIRES ARE WHITE NO. 20 UNLESS OTHERWISE SPECIFIED

MI 69922B

Figure 3-2. Test cables - schematic (sheet 21 of 25)

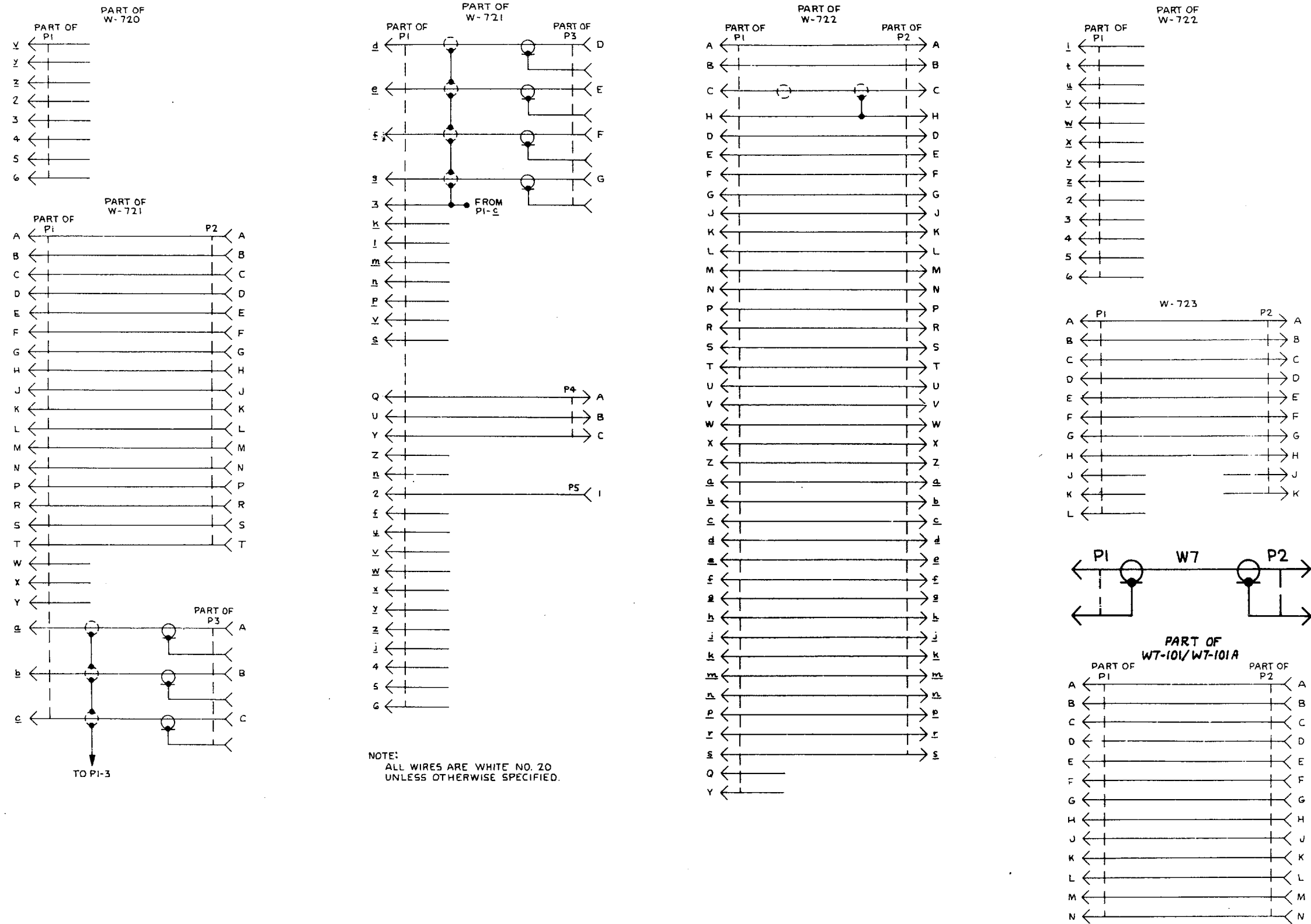

NOTE:
ALL WIRES ARE WHITE NO. 20
UNLESS OTHERWISE SPECIFIED.

MI 69923D

Figure 3-2. Test cables - schematic (sheet 22 of 25)

3-47/(3-48 blank)

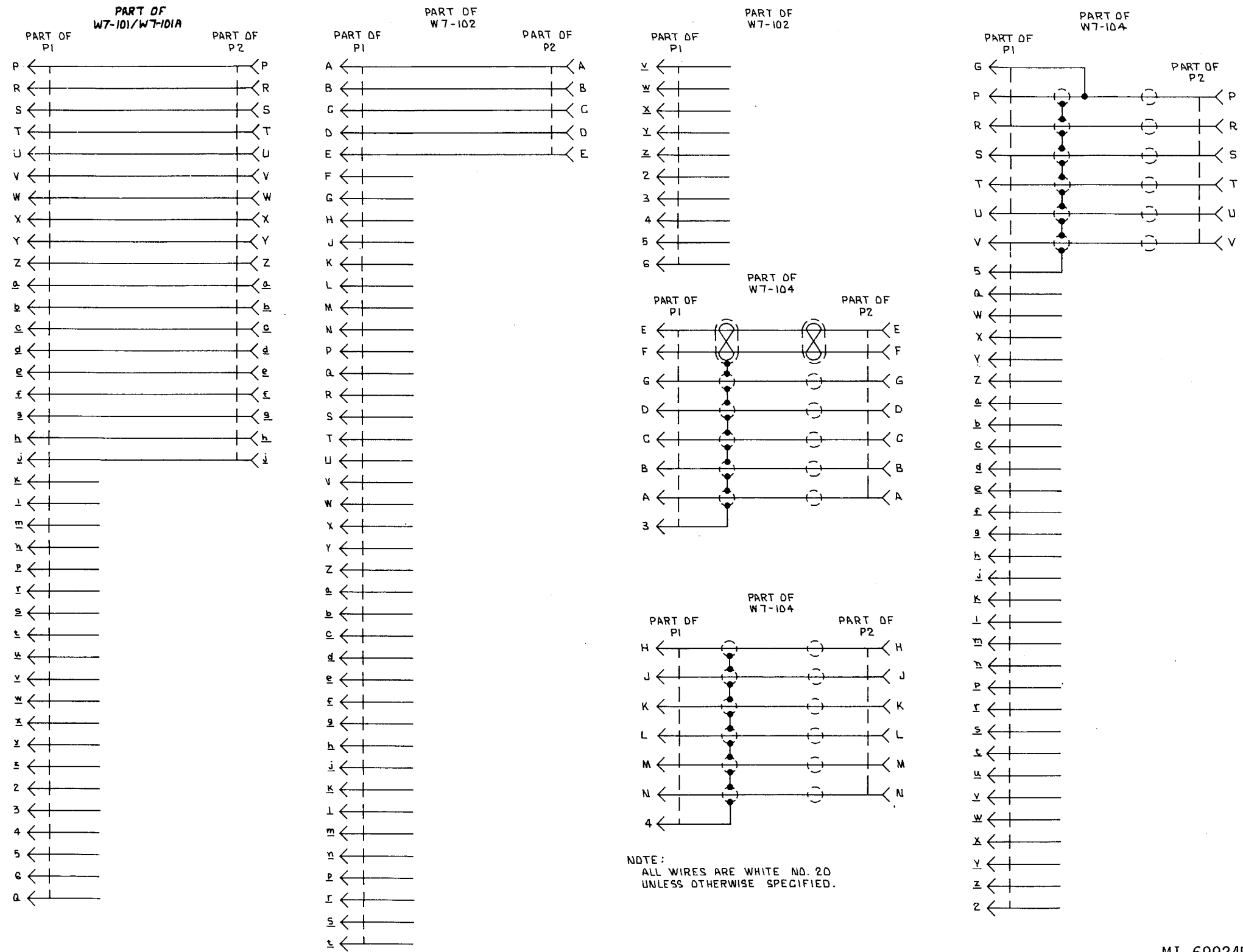

Figure 3-2. Test cables - schematic (sheet 23 of 25)
3-49/350 blank)

MI 69924B

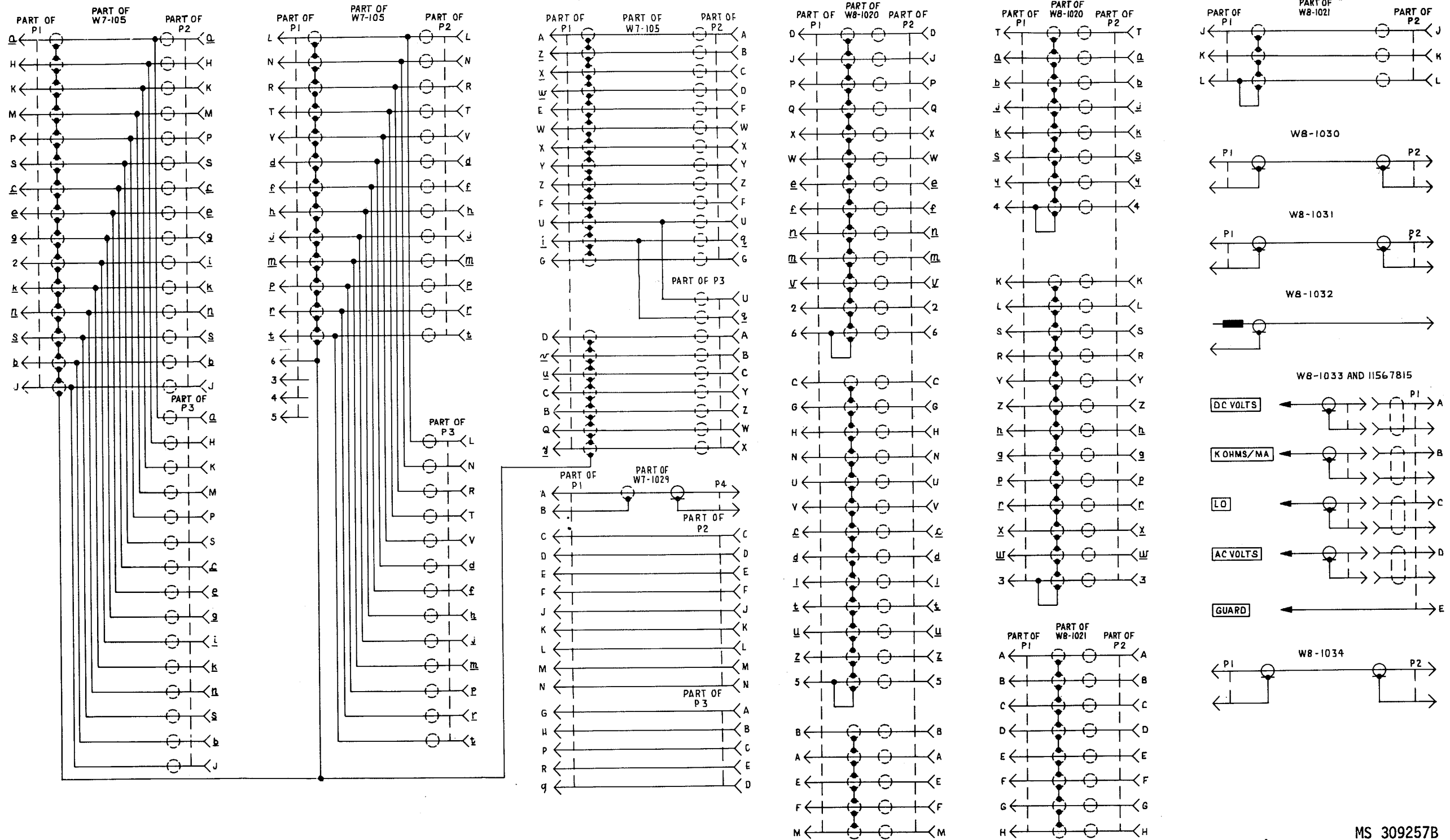
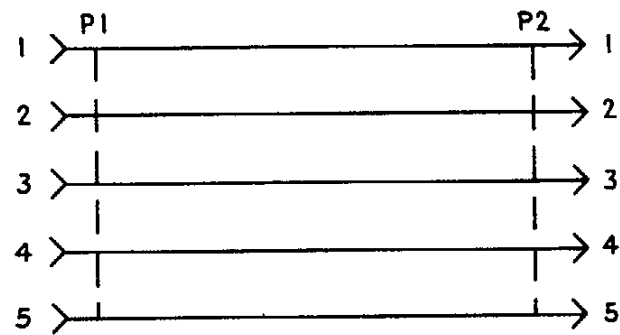
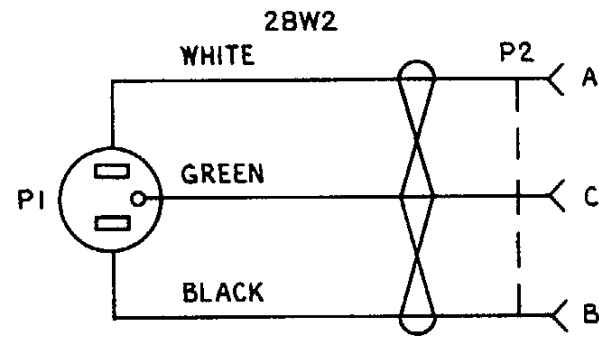

Figure 3-2. Test cables - schematic (sheet 24 of 25)

10677582 *(AE)(SEE NOTE)



NOTE:
REFER TO APPENDIX B FOR
SERIAL NUMBER EFFECTIVITY.



31A2W1 (P/O FG 2900)
10673120

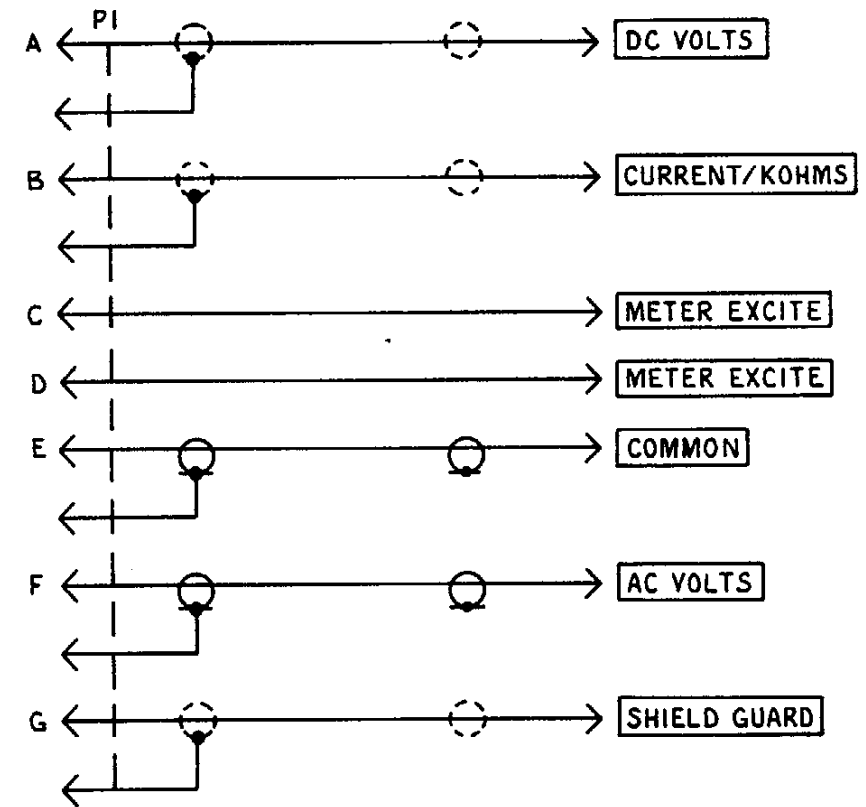

31W1 (P/O FG 2900)
10178673

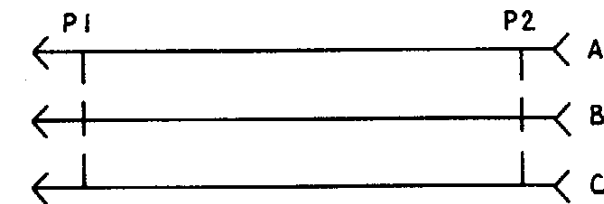

MS 166213A

Figure 3-2. Test cables - schematic (sheet 25 of 25)

Section II. PATCHBOARDS

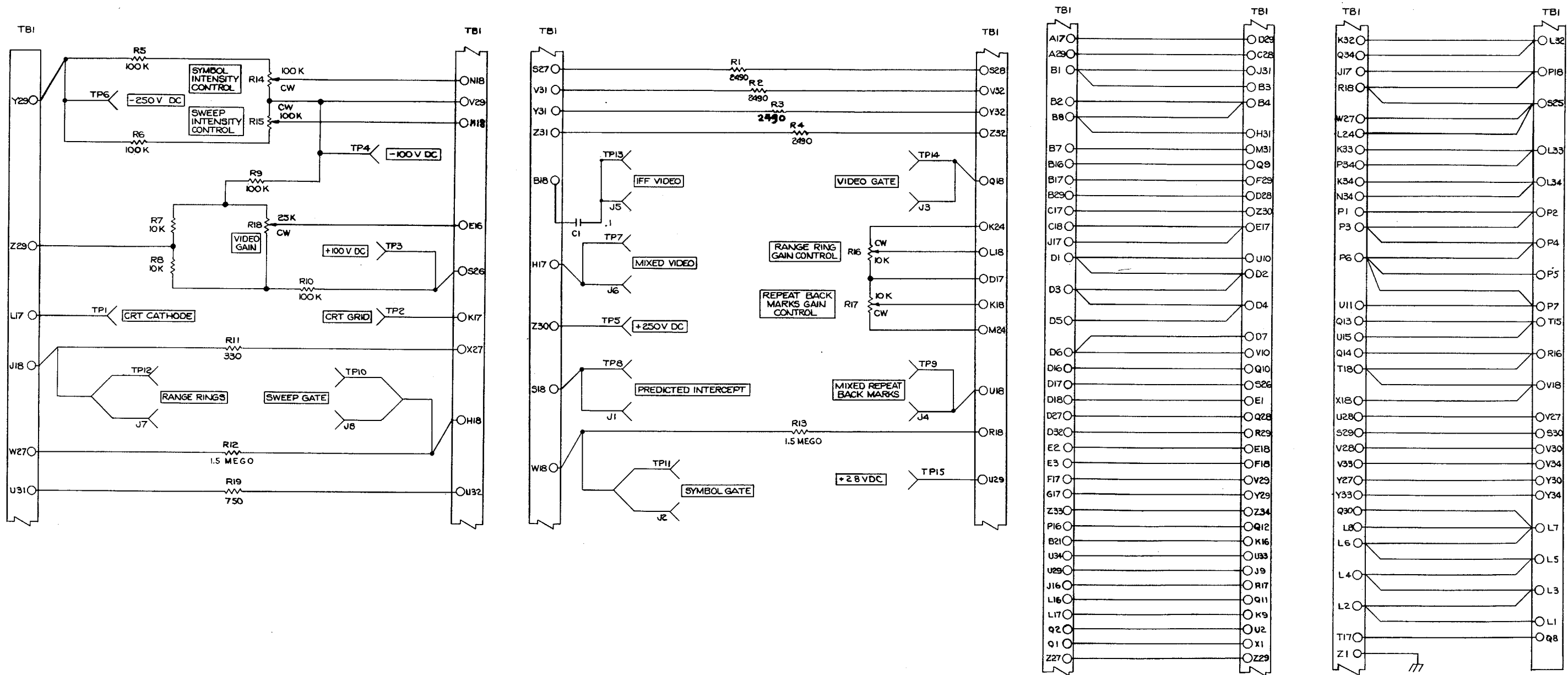

Figure 3-3. Pb BCC-402A 10104979 (FG 1010) - schematic

MS 571415

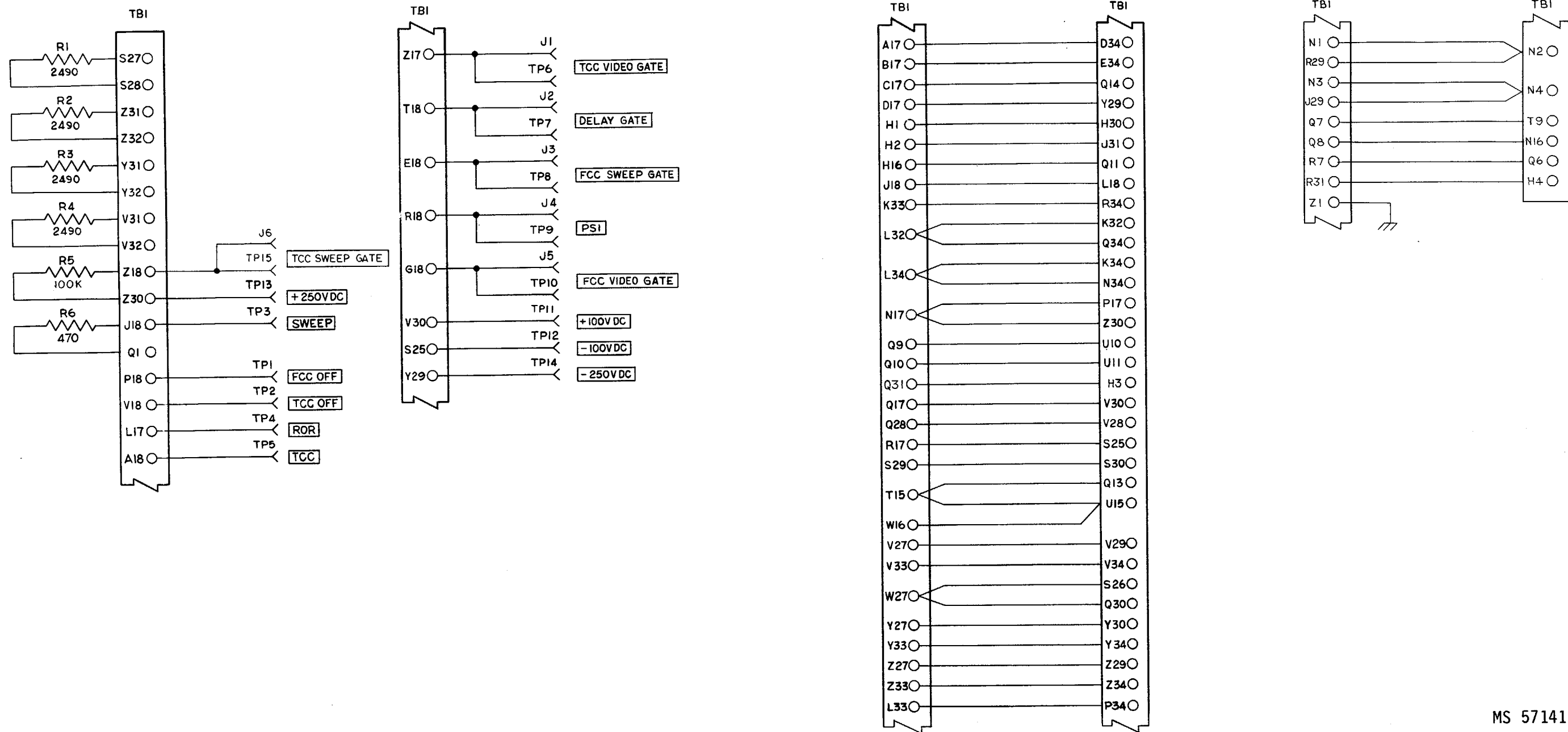
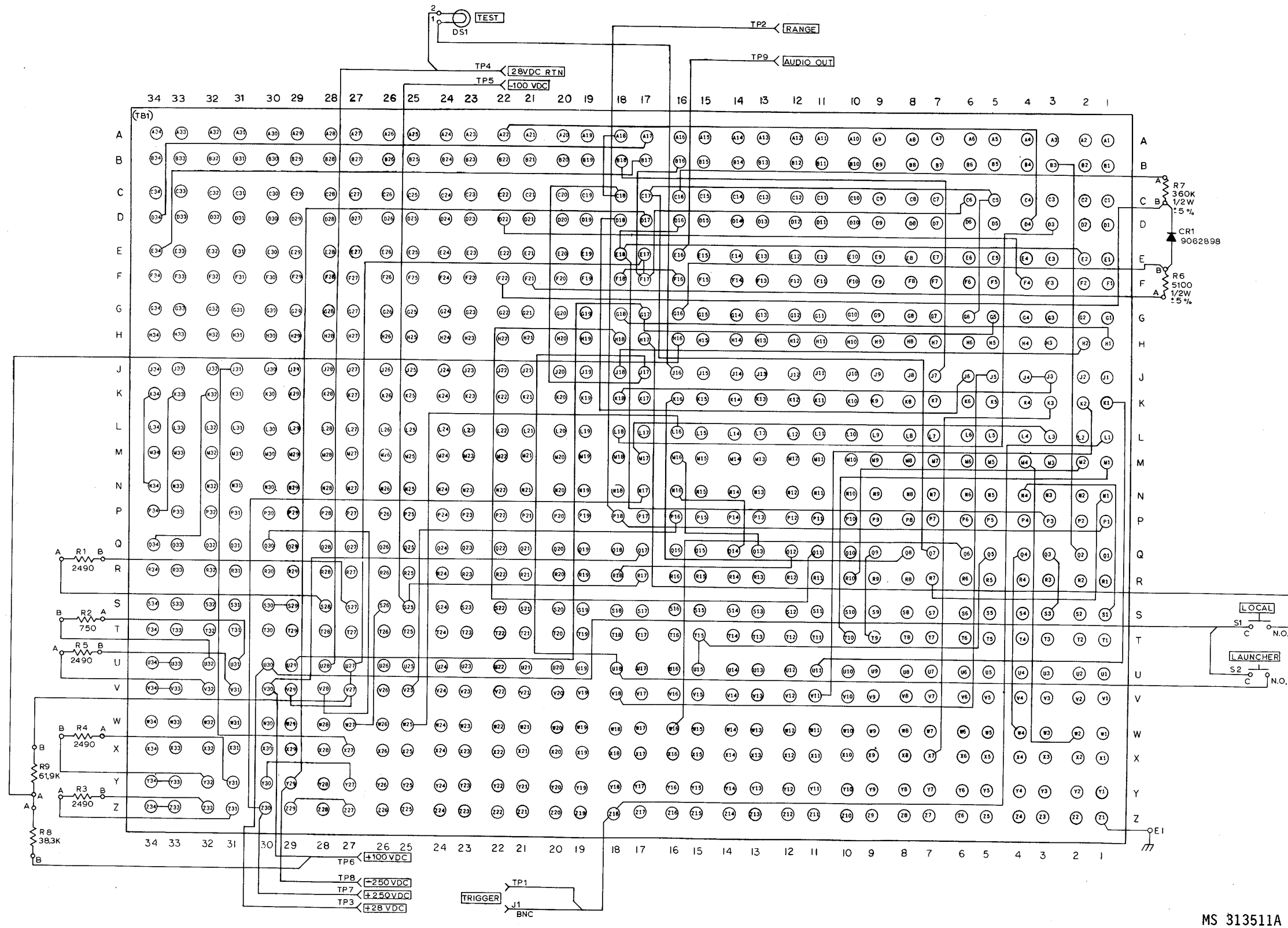
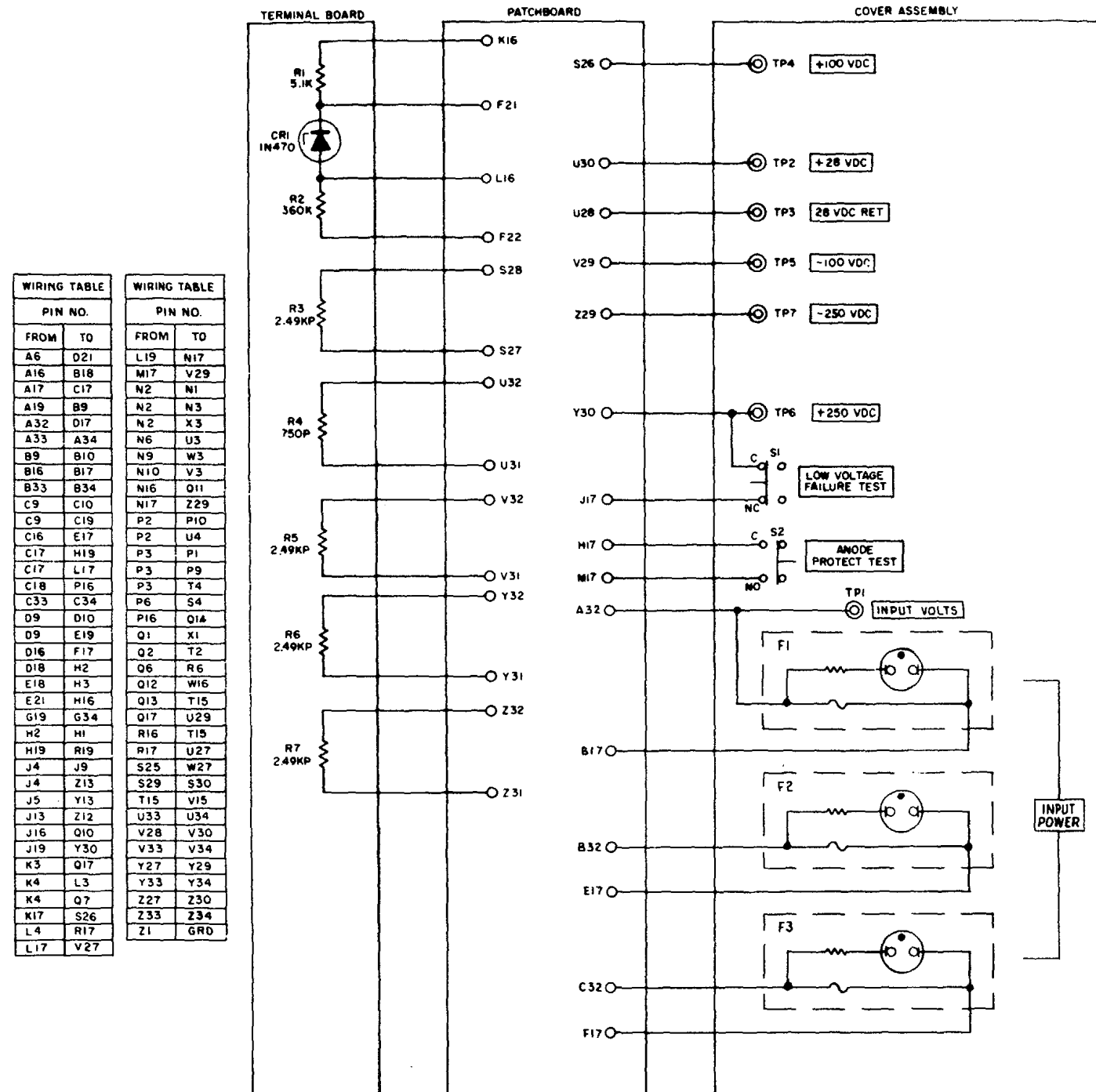

Figure 3-4. Pb BCC-404 9195670 (FG 1090) - schematic



MS 313511A

Figure 3-5. Pb BCC-406B 11568007 (FG 1015) - schematic



MI 69931

Figure 3-6. Pb BCC-413/422A 10175142 (FG 1020)-schematic.

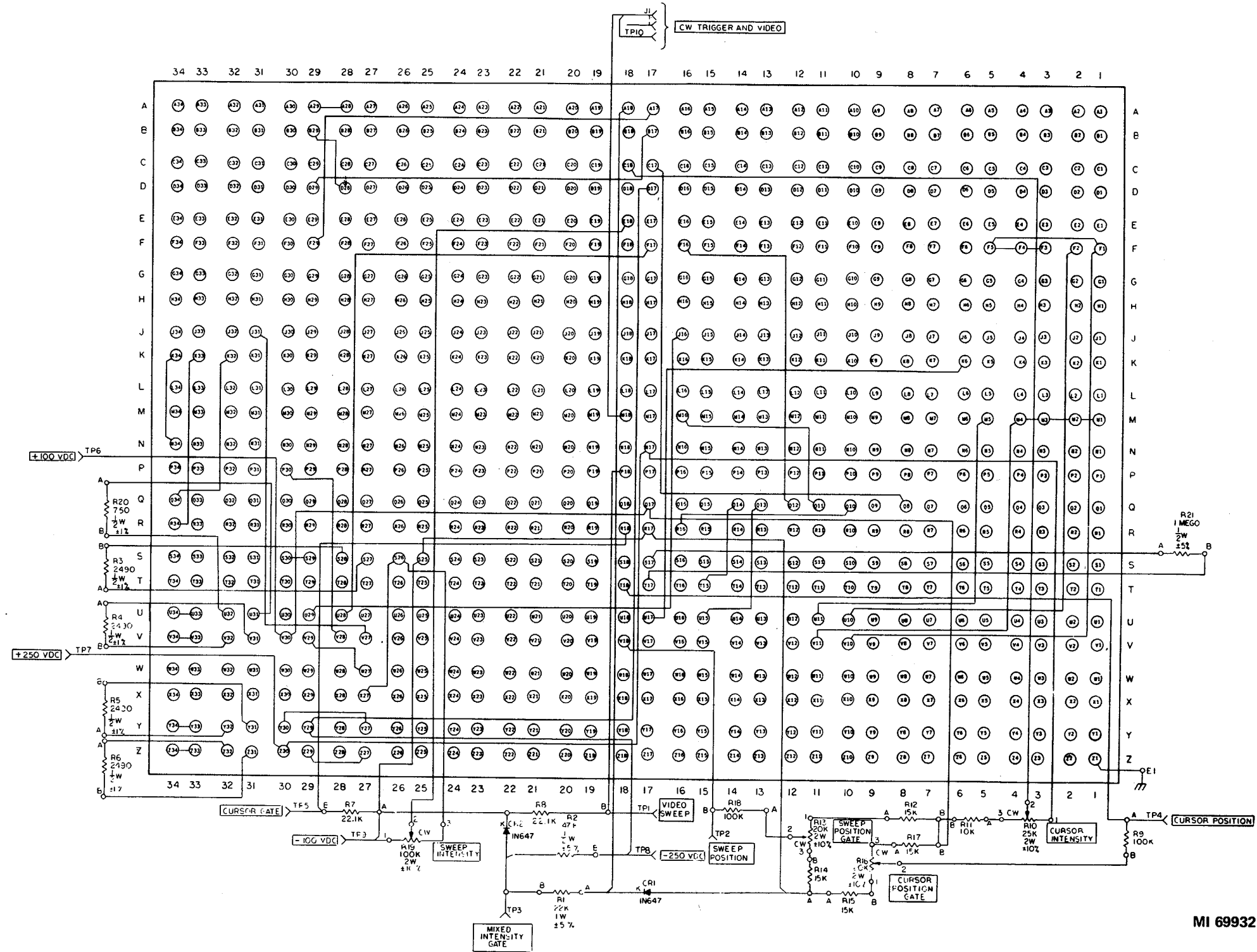

MI 69932

Figure 3-7. Pb BCC-417B 10673424 (FG 1025) - schematic

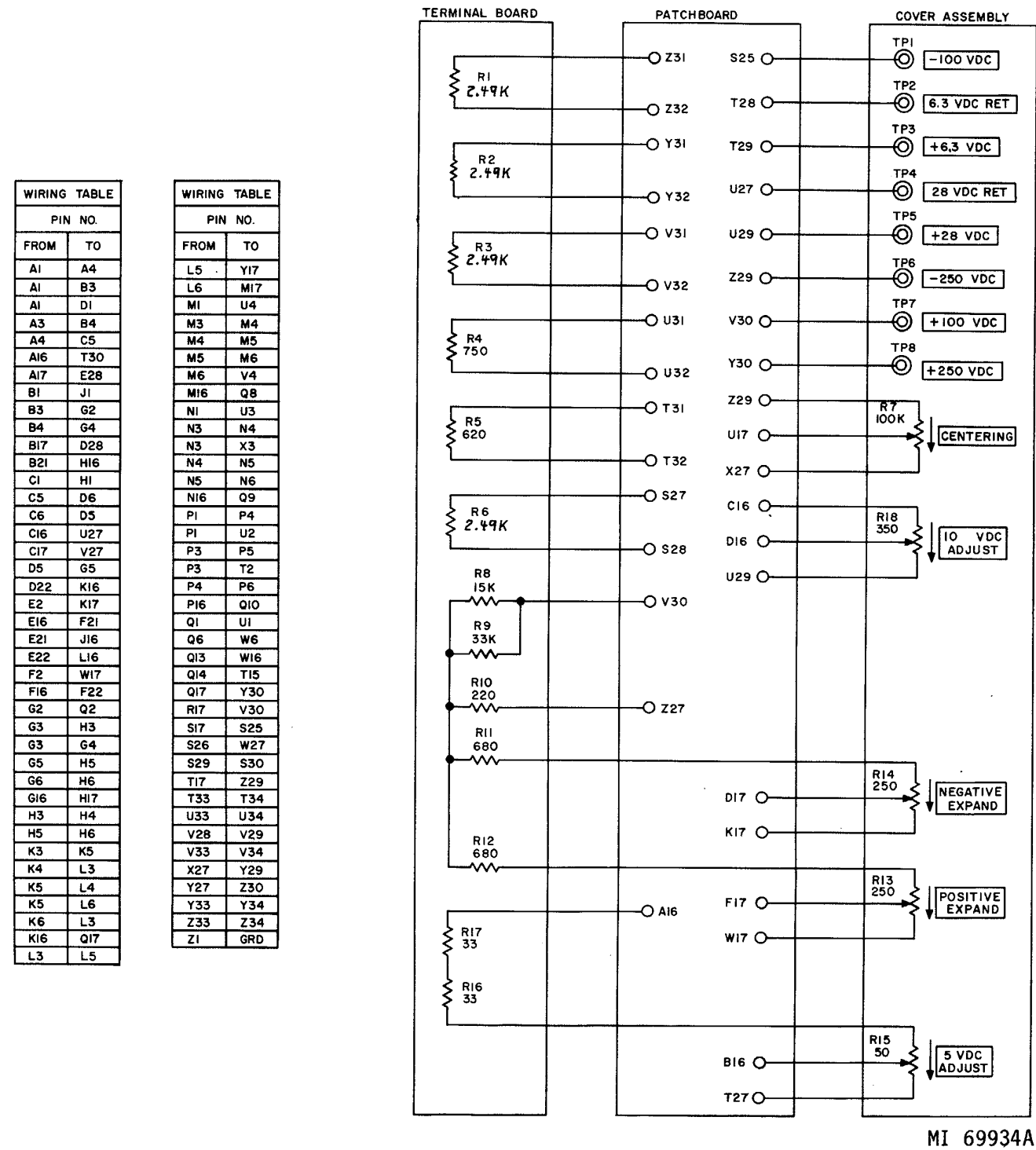

Figure 3-8. Pb BCC-421 9195678 (FG 1095) - schematic

WIRING TABLE	
FROM	TO
A1	A4
A1	B3
A1	D1
A3	B4
A4	C5
A16	T30
A17	E28
B1	J1
B3	G2
B4	G4
B17	D28
B21	H16
C1	H1
C5	D6
C6	D5
C16	U27
C17	V27
D5	G5
D22	K16
E2	K17
E16	F21
E21	J16
E22	L16
F2	W17
F16	F22
G2	Q2
G3	H3
G3	G4
G5	H5
G6	H6
G16	H17
H3	H4
H5	H6
K3	K5
K4	L3
K5	L4
K5	L6
K6	L3
K16	Q17
L3	L5

WIRING TABLE	
FROM	TO
L5	Y17
L6	M17
M1	U4
M3	M4
M4	M5
M5	M6
M6	V4
M16	Q8
N1	U3
N3	N4
N3	X3
N4	N5
N5	N6
N16	Q9
P1	P4
P1	U2
P3	P5
P3	T2
P4	P6
P16	Q10
Q1	U1
Q6	W6
Q13	W16
Q14	T15
Q17	Y30
R17	V30
S17	S25
S26	W27
S29	S30
T17	Z29
T33	T34
U33	U34
V28	V29
V33	V34
X27	Y29
Y27	Z30
Y33	Y34
Z33	Z34
Z1	GRD

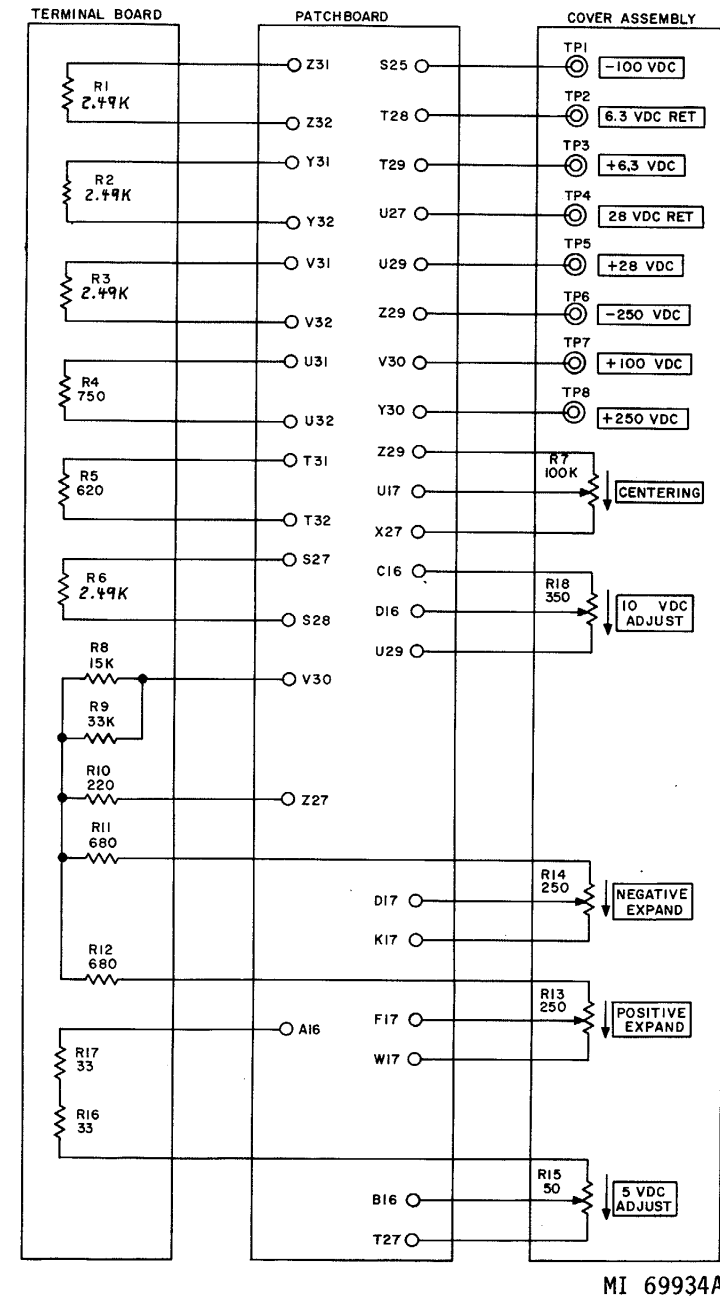
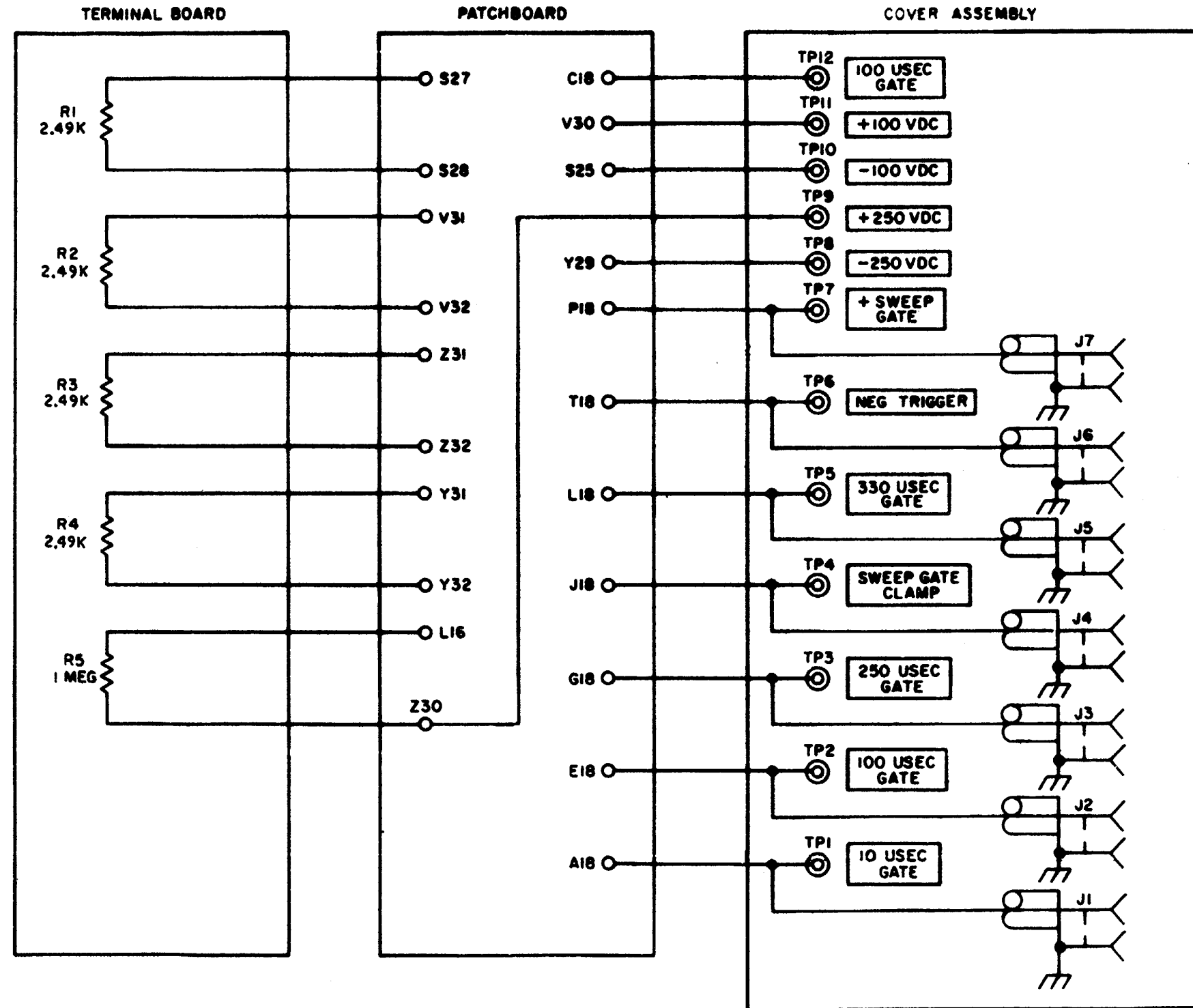

Figure 3-9. Pb BCC-423 9195679 (FG 1030) - schematic

WIRING TABLE	
PIN NO.	
FROM	TO
A17	D34
B17	C34
C17	Q14
D17	Y29
J5	Z16
J16	Q8
K1	K2
K2	K3
K3	K4
K4	Q6
K16	Y16
K31	W27
K32	Q34
K33	R34
K34	L34
L6	T17
L32	K32
L33	P34
L34	N34
N1	S11
N2	T11
N3	N4
N4	N5
N5	U11
N6	Q13
N17	Z30
P28	X27
Q7	R7
Q9	U9
Q10	V10
Q11	T15
Q17	V30
Q30	V28
R17	S25
S26	V27
S29	S30
T15	U15
U15	W16
V28	V29
V33	V34
Y27	Y30
Y33	Y34
Z27	Z29
Z33	Z34
Z1	GRD



MI 69935A

Figure 3-10. Pb BCC-429A 9166733 (FG 1035) - schematic

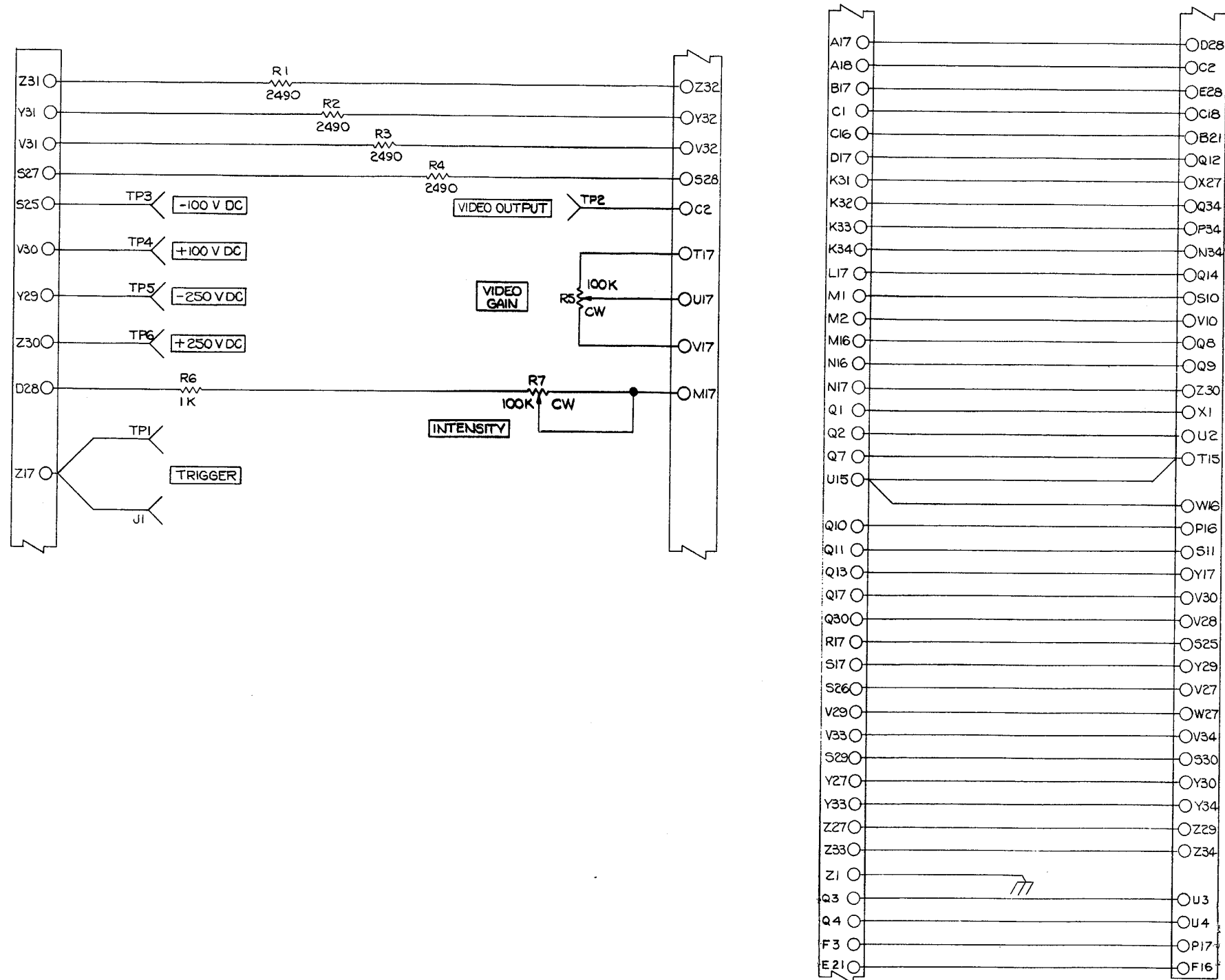

MS 571417

Figure 3-11. Pb BCC-435 9196543 (FG 1040)-schematic.

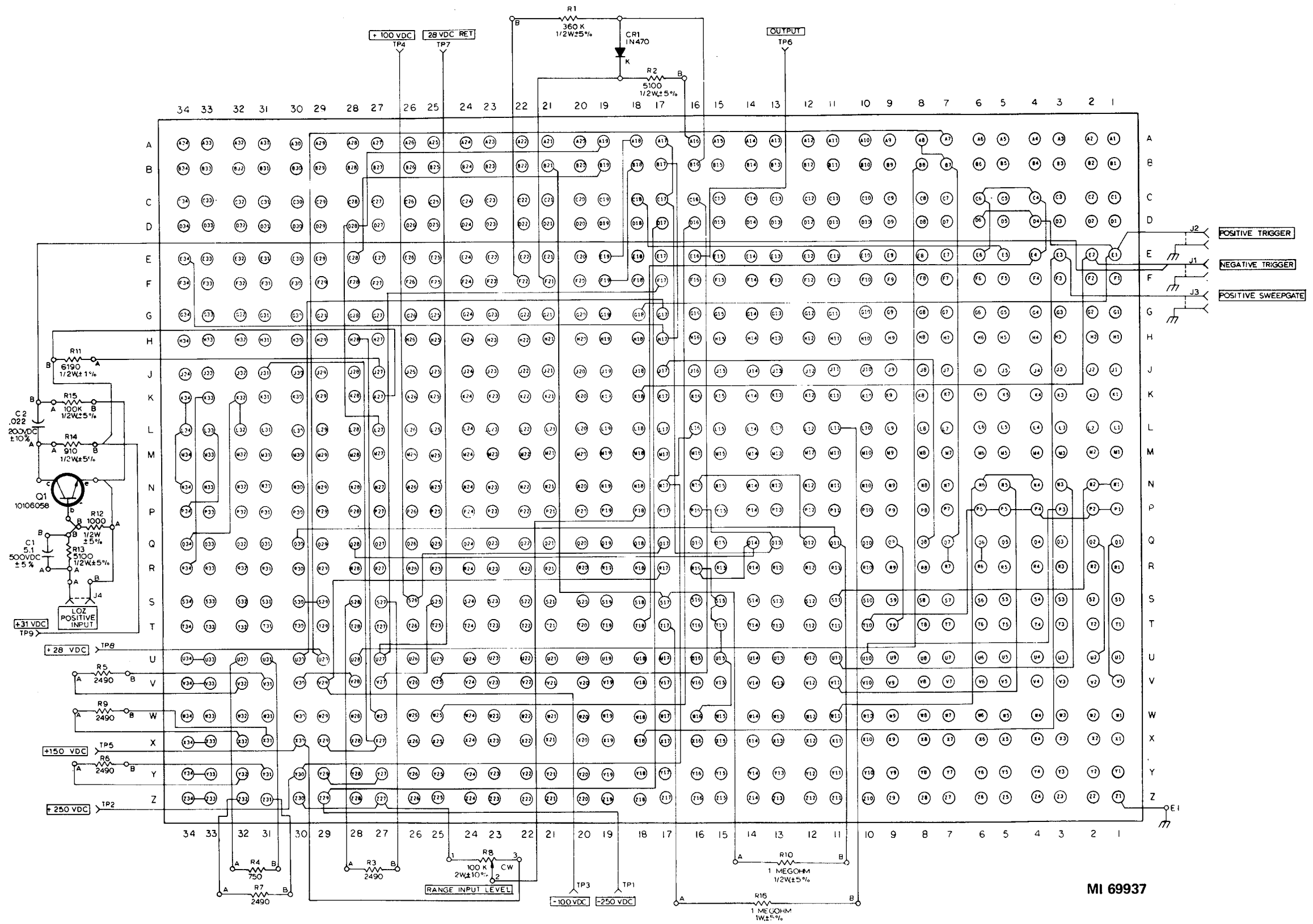

MI 69937

Figure 3-12. Pb BCC-451A 10675081 (FG 1045)-schematic

WIRING TABLE		WIRING TABLE		WIRING TABLE	
FROM	TO	FROM	TO	FROM	TO
A2	A6	C26	G20	L3	R17
A3	L2	D16	X18	L4	L5
A4	A5	D17	D19	L5	L6
A5	A8	D19	Y29	L6	L7
A6	A7	D20	Y18	L7	L8
A7	A9	D24	E28	L8	L9
A8	A15	D24	H19	L9	L10
A9	A10	D27	H24	L10	L11
A10	A11	D27	F29	L11	L12
A11	A13	E4	U4	L12	L13
A13	G16	E6	E7	L13	L14
A14	L3	E6	T4	L14	L15
A18	E30	E16	H16	L15	S26
A19	D28	E17	H18	L16	U16
A19	J19	E18	G20	L17	L19
A20	C12	E21	Z18	L20	U20
A20	V18	E24	M24	M1	C18
A21	M16	E26	H20	M7	N8
A26	A28	F4	F6	M8	N7
A29	B30	F6	F7	M12	Y19
A30	A32	F7	F8	M17	M19
A30	B29	F8	F9	M10	N11
A33	A34	F9	F10	N16	P16
B1	Q1	F10	F11	N17	N19
B1	B2	F16	W17	N19	Z30
B2	B3	F18	H20	N20	P20
B3	B4	F29	F30	P1	W1
B4	B5	G16	Q17	P4	W3
B5	B6	G17	G19	P7	P8
B6	B7	G19	U30	P7	X3
B7	B8	H7	U1	P9	P10
B8	B9	H16	J16	P10	P11
B9	B10	H17	M8	P12	X1
B10	B11	H18	H18	P16	Q14
B11	B13	H19	Q18	P20	G20
B13	B14	J6	S3	Q2	S2
B14	B15	J10	J11	Q12	Q20
B18	K8	J16	L16	Q13	R16
B19	D24	J17	N8	Q17	Q19
B20	E19	J18	M6	Q19	V30
B26	B30	J19	R18	R16	T15
B30	D27	J20	K20	R17	R19
C4	C7	K4	K6	R19	S25
C5	E21	K6	M18	S29	S30
C6	Z17	K7	U18	T15	X16
C7	L18	K9	W20	U28	V28
C8	C9	K10	V20	U33	U34
C9	C10	K11	X20	V28	V29
C10	G18	K13	R20	V33	V34
C11	C12	K12	S20	W18	W20
C13	W19	K14	T20	X18	X30
C14	Y19	K15	Z19	X27	Y29
C15	Z20	K17	K19	X33	X34
C17	C19	K20	L20	Y27	Y30
C17	Q11	L1	L2	Y33	Y34
C18	E29			Z1	ORD
				Z27	Z29
				Z33	Z34

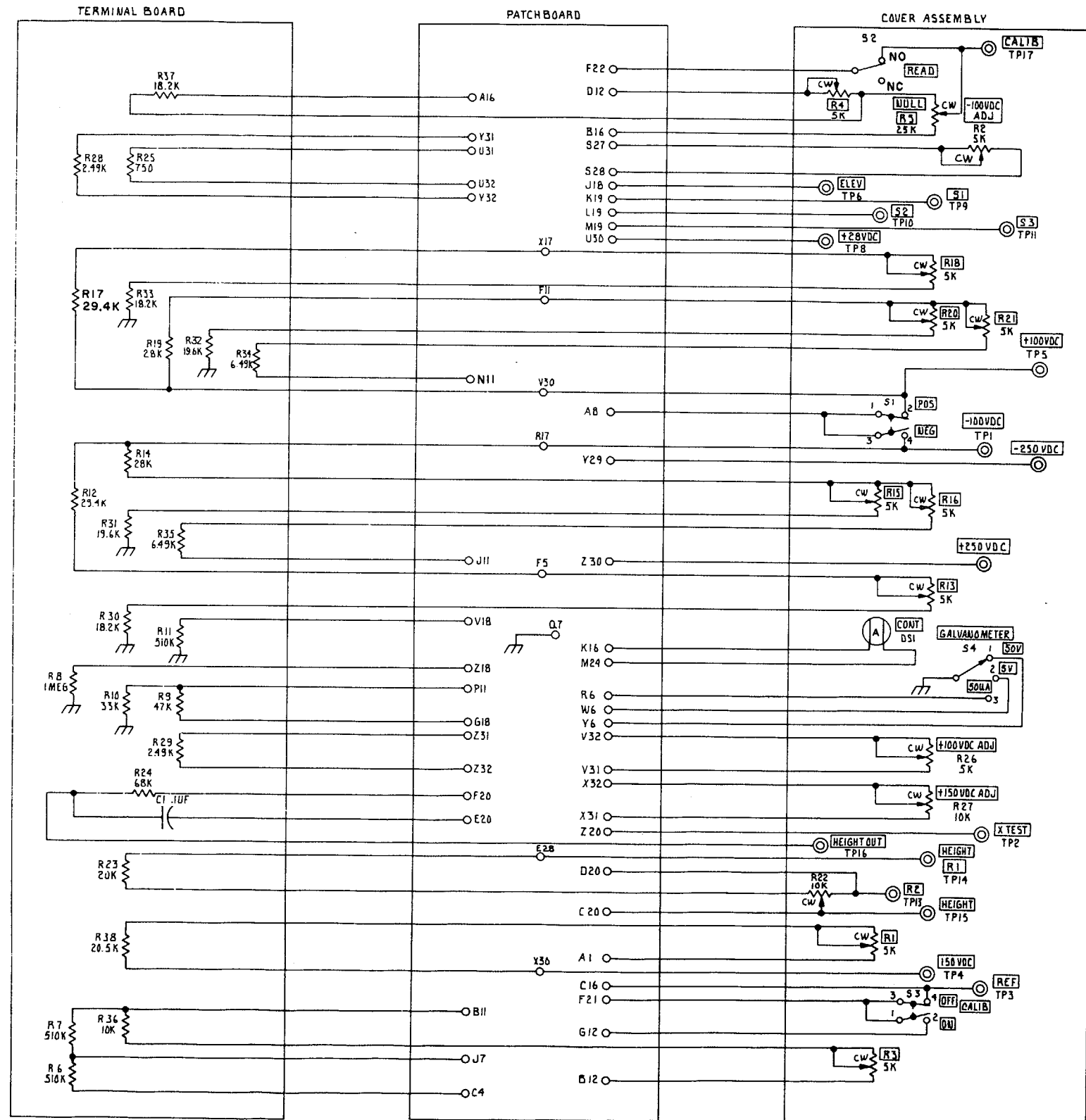

MI 69938A

Figure 3-13. Pb BCC-482A 10177210 (FG 1050)-schematic.

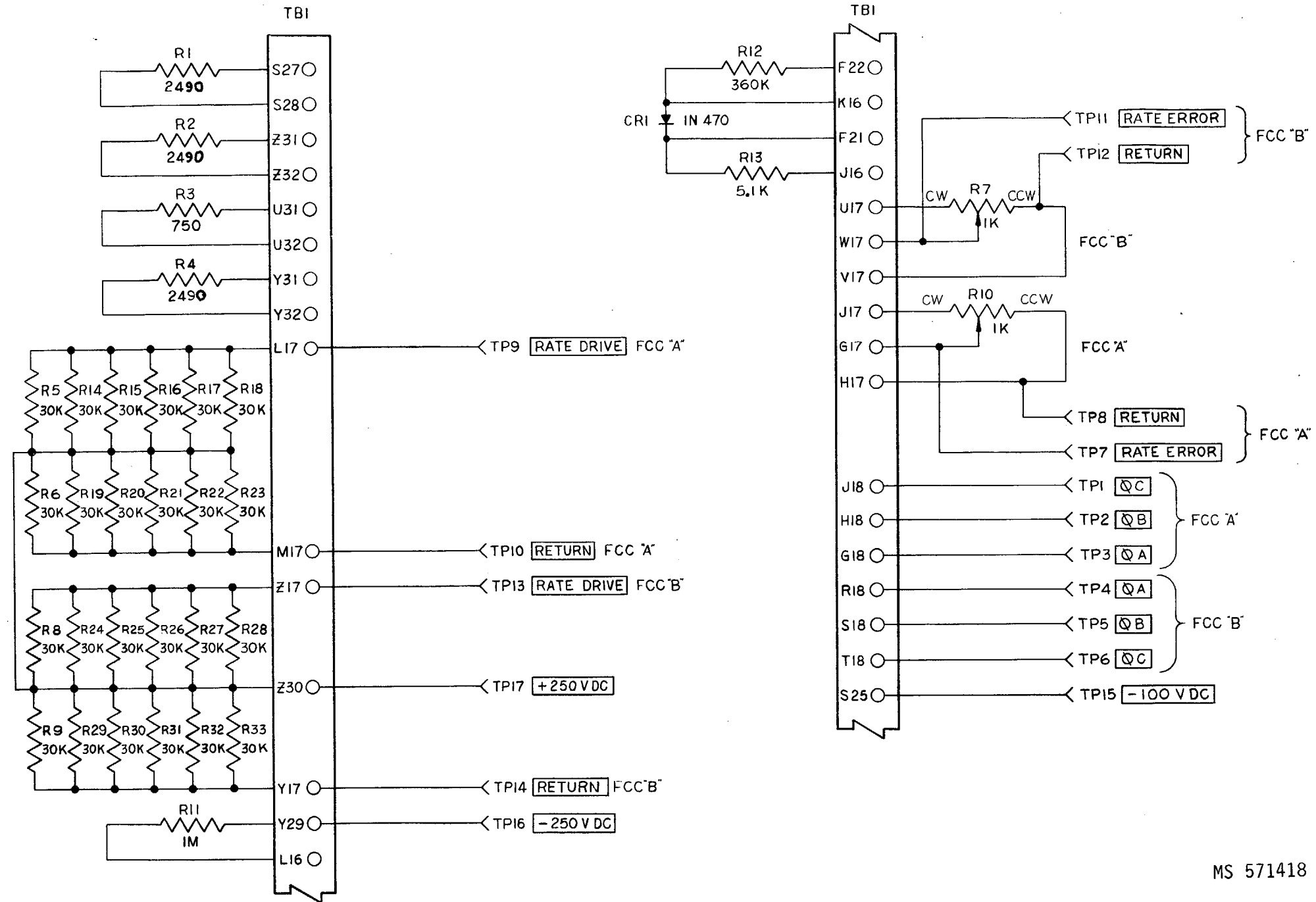

MS 571418

Figure 3-14. Pb BCC-484 9195690 (FG 1055)-schematic (sheet 1 of 2).

3-64.1 (3-64.2 blank)

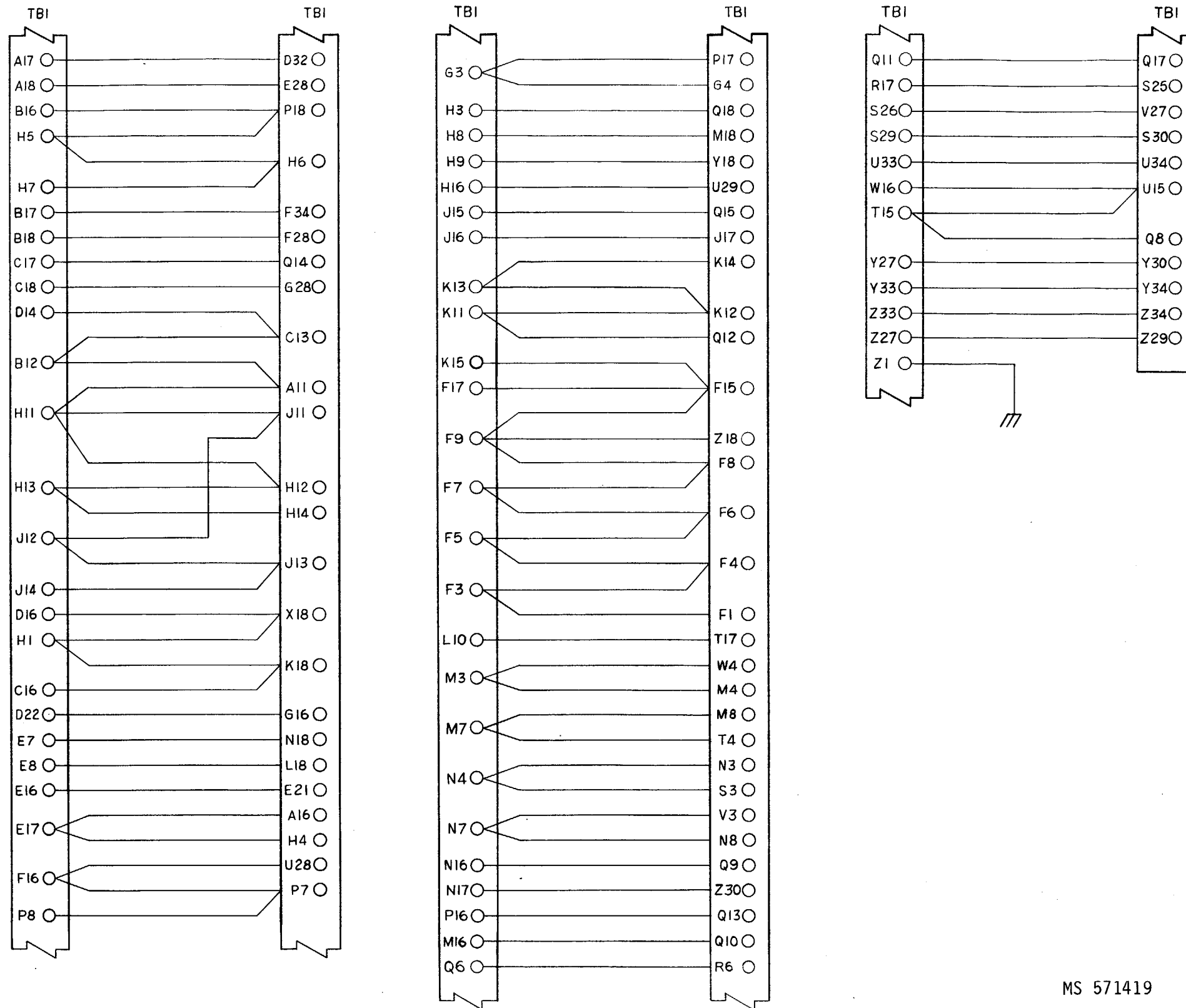

Figure 3-14. Pb BCC-484 9195690 (FG 1055)-schematic (sheet 2 of 2).

MS 571419

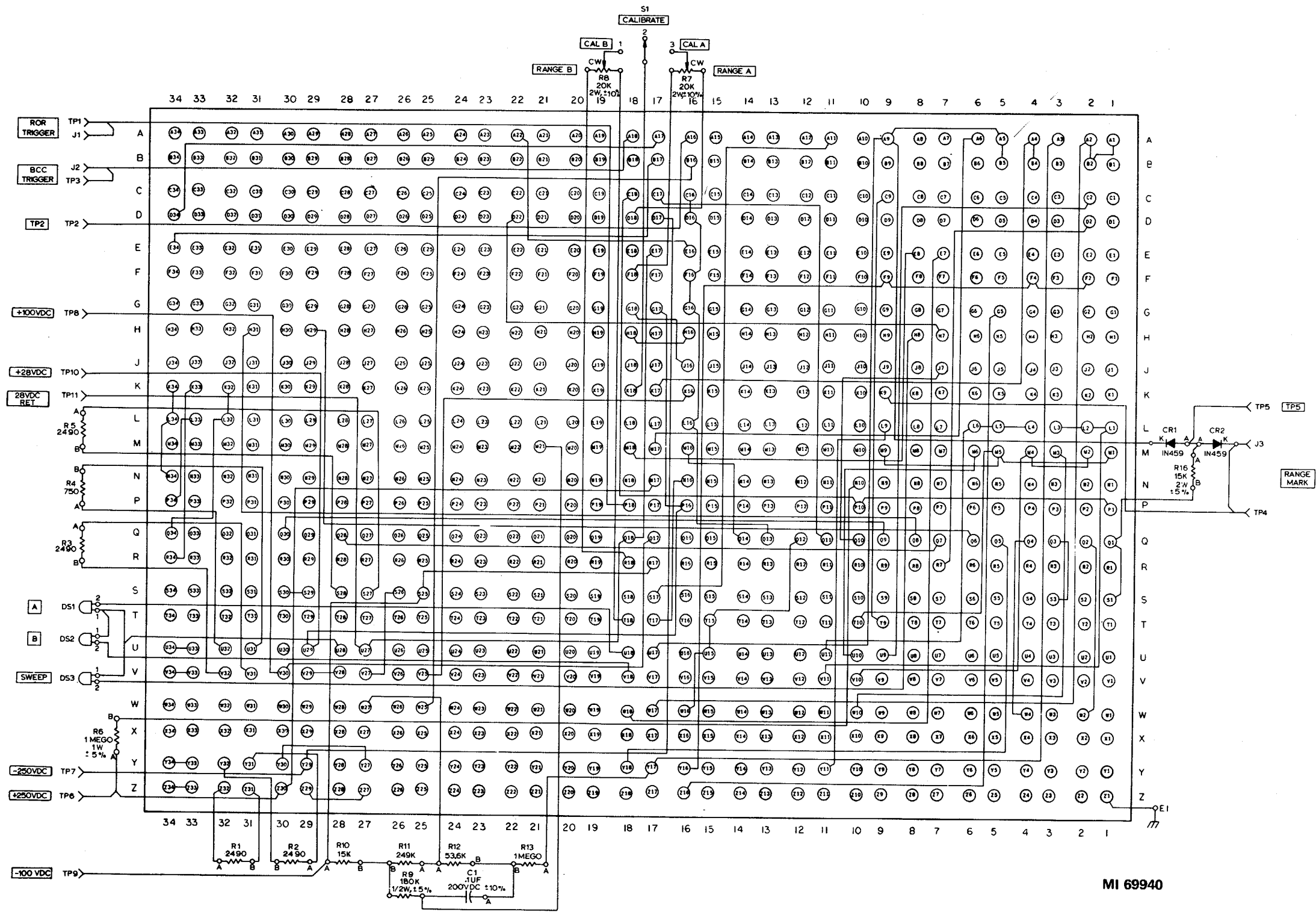
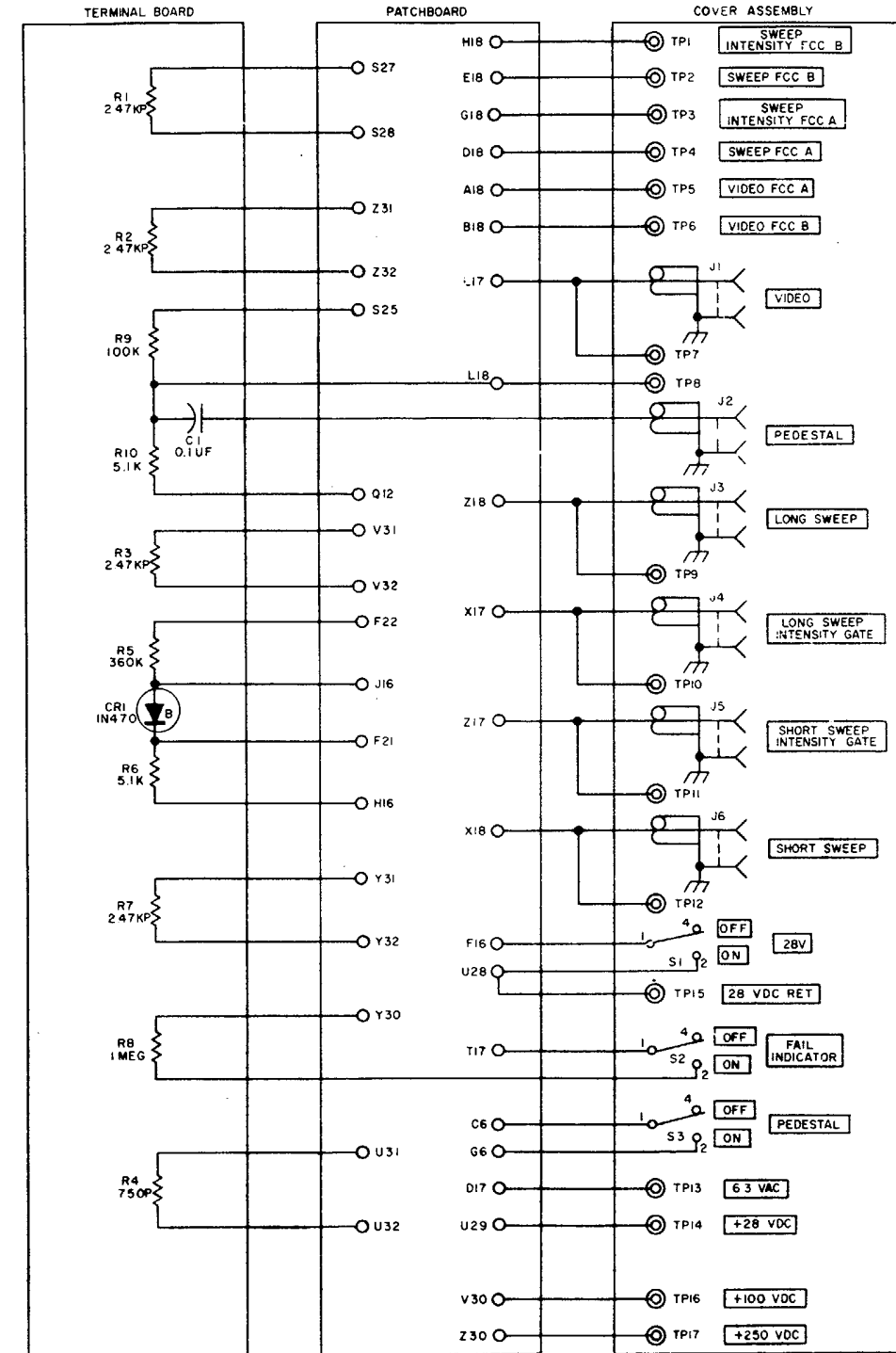

Figure 3-15. Pb BCC-486A 10675764 (FG 1060)-schematic.

WIRING TABLE	
FROM	TO
A1	A3
A1	R31
A2	A4
A4	L31
A5	A6
A6	H31
A6	Q6
A7	D34
A22	D16
B7	Q18
B8	T18
B9	R18
B10	V18
B16	E21
B17	E34
C2	G2
C4	G4
C13	G13
C14	Q14
C16	C18
C17	Q14
D7	G17
D8	J17
D9	U17
D10	M17
D11	D12
D11	W18
E1	E3
E1	R29
E2	E4
E4	E5
E5	E6
E6	L29
E16	Q5
F1	F2
F2	F3
F3	F4
F4	F6
F6	F7
F7	F8
F8	F9
F9	F10
F10	F11
F11	F12
F12	F13
F13	F14
F14	F15
F14	J14
F15	F17
F18	M11
G1	G2
G1	P1
G3	G4
G3	N3
G4	G6
G7	G8
G8	G9
G8	P8
G9	G10
G11	G12
G11	N11
G13	H13
G14	K14
G15	K15
G16	U29
H14	M14
H13	K13

WIRING TABLE	
FROM	TO
J13	M13
J18	K16
K13	N13
K14	N14
K32	Q34
K33	R34
K34	L34
L1	L2
L1	X10
L2	L3
L3	L4
L5	L6
L6	U10
L7	L9
L7	U4
L8	L10
L8	T4
L16	Q12
L32	K32
L34	N34
M1	M3
M1	U11
M2	M4
M2	T11
M4	M5
M5	M6
M7	M8
M7	V17
M9	M10
M10	K18
M10	M12
M10	Y18
M16	Q13
N3	N4
N4	N6
N11	N12
N13	P13
N14	P14
N16	N18
N17	Z30
P1	P2
P8	P9
P9	P10
P16	P18
Q1	S1
Q2	W2
Q3	W3
Q4	T15
Q17	V30
Q28	W27
Q28	Q30
R17	S25
S26	V27
S29	S30
T15	U15
U15	W16
U33	U34
V28	V29
V33	V34
Y27	Y29
Y33	Y34
Z27	Z29
Z33	Z34
Z1	GRD



MI 69941

Figure 3-16. Pb BCC-487C 10105101 (FG 1065)-schematic.

WIRING TABLE	
PIN NO.	
FROM	TO
A17	D34
A18	E19
A19	D28
A19	J18
B17	E34
B18	F19
B19	E28
B19	H17
B21	S17
C17	Q14
D17	Y29
D21	G18
E17	U27
E18	V25
G17	U29
J16	T17
J17	J18
J31	W27
K32	Q34
K33	P34
K34	N34
N17	Z30
Q1	S1
Q2	T2
Q3	W3
Q4	S4
Q7	R7
Q8	T15
Q9	T9
Q10	J10
Q12	T11
Q13	X13
Q17	V30
Q30	X27
R17	S25
S26	V27
S29	S30
T15	U15
U15	W16
U33	U34
V28	V29
V33	V34
W25	Z18
Y27	Y30
Y33	Y34
Z27	Z29
Z33	Z34
Z1	GRD

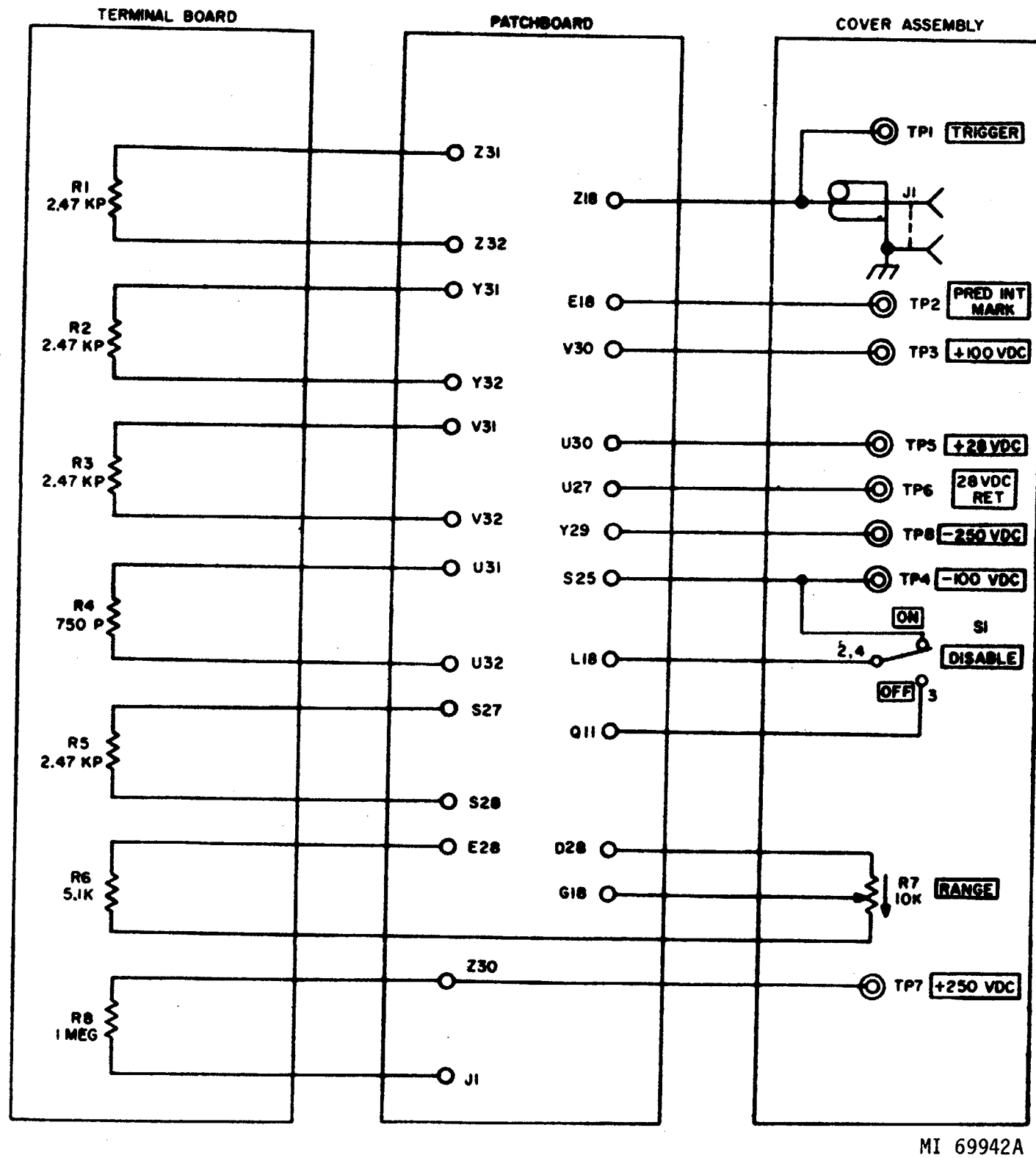

MI 69942A

NOTE: REFER TO APPENDIX B FOR SERIAL NUMBER EFFECTIVITY.

Figure 3-17. Pb BCC-491 9195697 *(AG) (see note) (FG 1070)-schematic.

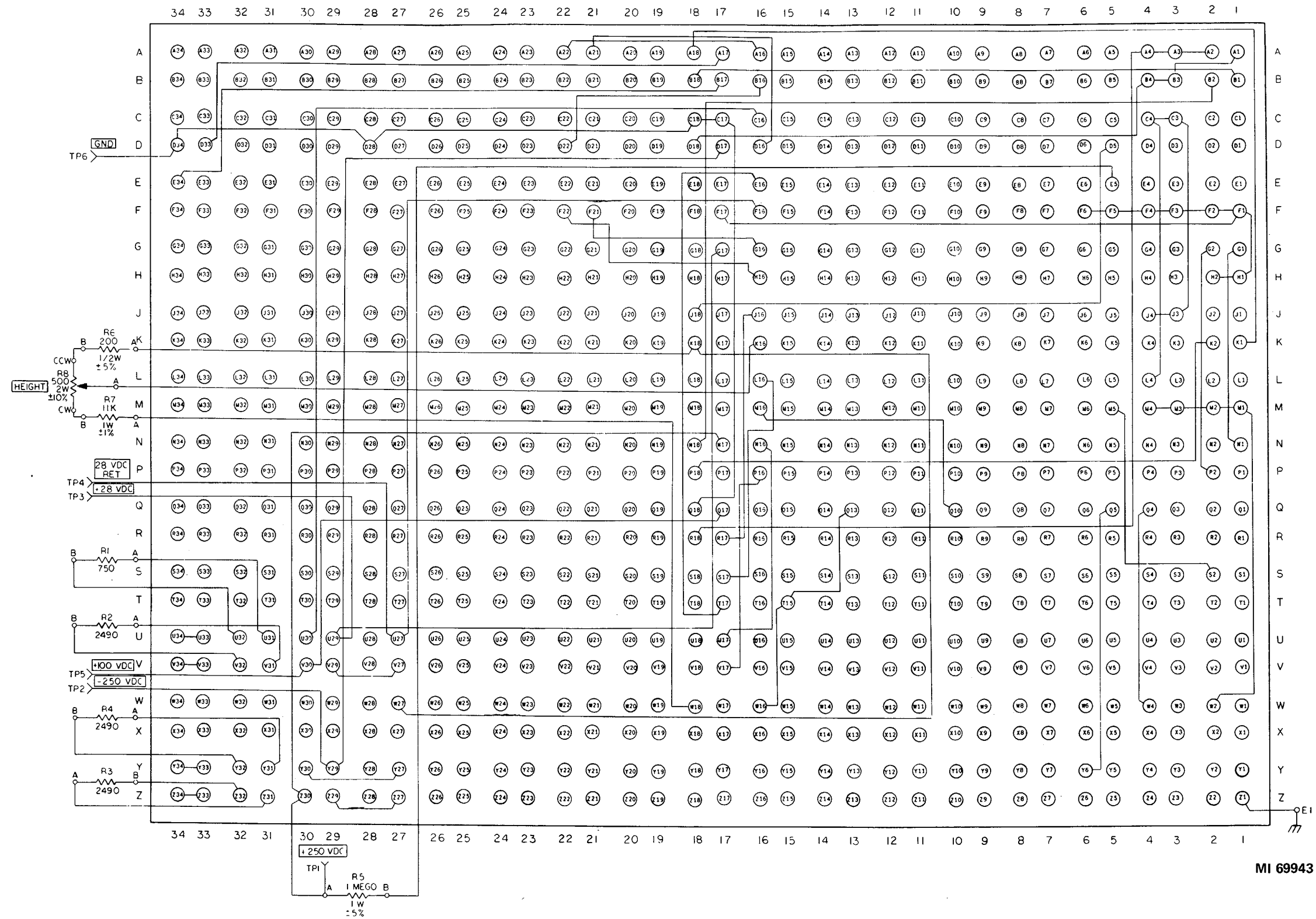

MI 69943

Figure 3-18. Pb BCC-492A 10671756 (FG 1075)-schematic

WIRING TABLE	
PIN NO.	
FROM	TO
A17	G16
A31	A32
A33	E34
B17	F17
B21	D17
B31	D32
C17	E17
D21	K16
D28	F31
D33	D34
E17	F22
E31	H16
F17	Q14
F21	Q11
G1	H1
G2	G3
G3	H3
G17	H1
H1	H2
H1	K1
H2	J3
H3	J2
J2	K2
J3	K3
Q1	T1
Q2	U2
Q3	U3
Q4	S4
Q6	X6
Q12	W16
Q13	T15
V28	V30
V33	V34
Z1	GRD

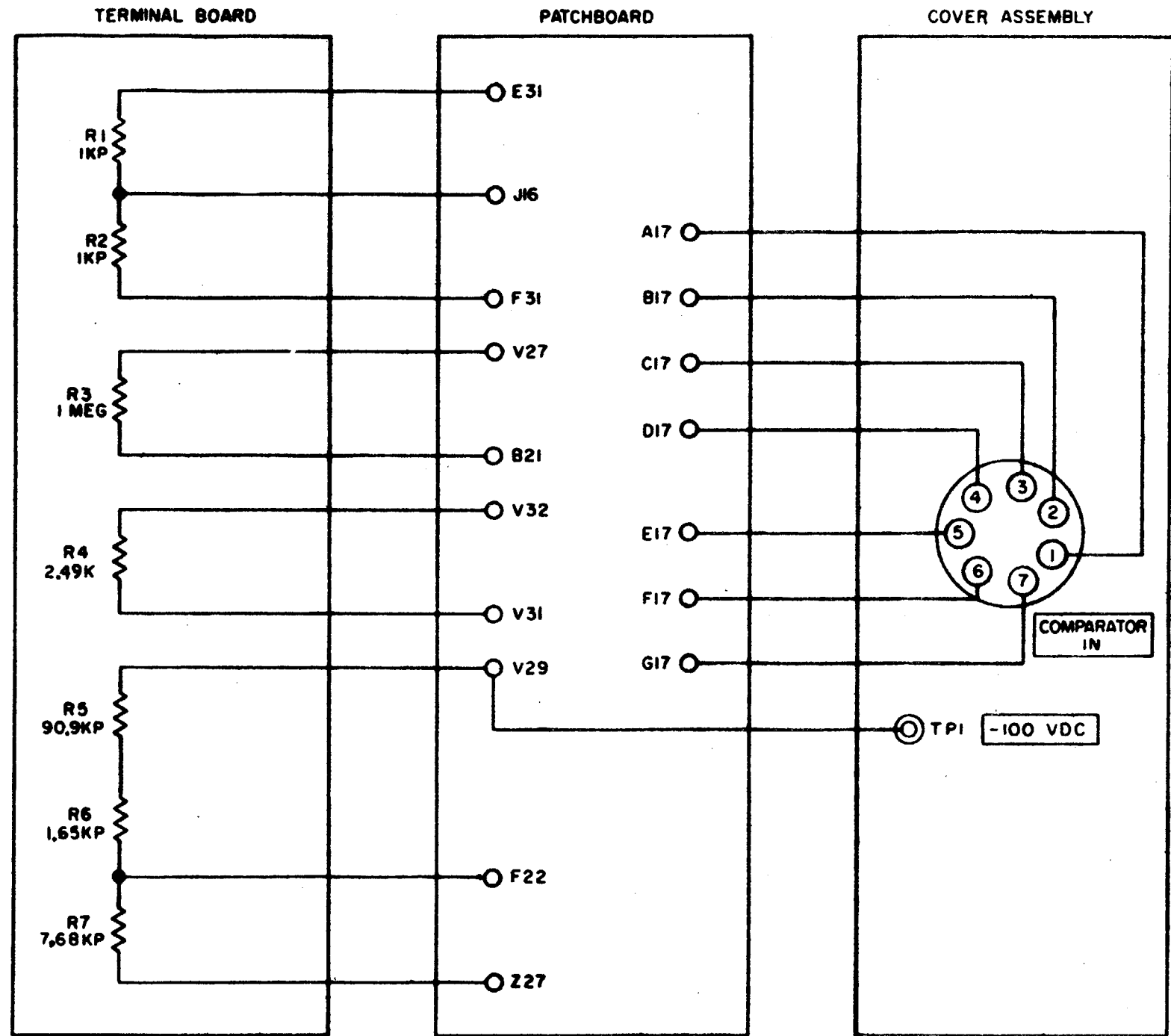

MI 69944A

Figure 3-19. Pb BCC-493 9195699 (FG 1080)-schematic.

WIRING TABLE	
FROM	TO
A1	Z20
A2	W20
A3	AB
A3	J20
A4	M20
A10	Y20
A11	D20
A16	B21
A17	D28
A19	C5
A22	C16
B1	T19
B2	J19
B3	M19
B16	Z17
B17	E28
B19	E4
C6	C19
C7	E19
C17	Q14
C20	A20
C20	F21
D1	S20
D2	D10
D3	L20
D4	W19
D5	Z19
D6	D9
D9	S19
D10	P20
D16	E21
D17	Y29
D19	E5
E3	E8
E7	R19
E8	V19
E16	F22
E34	S17
F17	T30
F19	G19
F20	V28
F21	V27
F34	T17
G8	U20
G9	V20
G10	E20

WIRING TABLE	
FROM	TO
G11	Y20
G16	G19
G16	Y19
G17	T28
G19	G20
G20	H20
G34	U17
G34	B20
H20	K19
K19	K20
K20	Q20
K31	Q11
K32	Q34
K32	L32
K33	R34
K34	L34
L33	P34
L34	N34
M3	M8
M3	M4
M4	Y6
M5	M6
M6	X6
M7	W6
M16	Q12
N1	X1
N1	N2
N2	N3
N3	N4
N5	N6
N6	N7
N7	T1
N8	N9
N9	N10
N10	N11
N10	V1
N16	P16
N17	N20
N17	Z30
N19	N20
P1	P2
P2	T2
P2	P3
P3	P4
P4	P8
P5	W2

WIRING TABLE	
FROM	TO
P5	P6
P6	P7
P8	P9
P9	P10
P10	P11
P16	P19
P16	Q13
Q1	V11
Q4	T4
Q9	T15
Q10	R29
Q13	Q28
Q17	S26
Q19	E6
Q20	U19
Q30	X27
R17	R20
R17	V29
S25	X27
S29	S30
T4	W3
T15	U15
T33	T34
U15	W16
U19	X19
U19	Q16
V11	X10
V27	V30
V33	V34
Y27	Y30
Y33	Y34
Z27	Z29
Z33	Z34
Z1	GRD

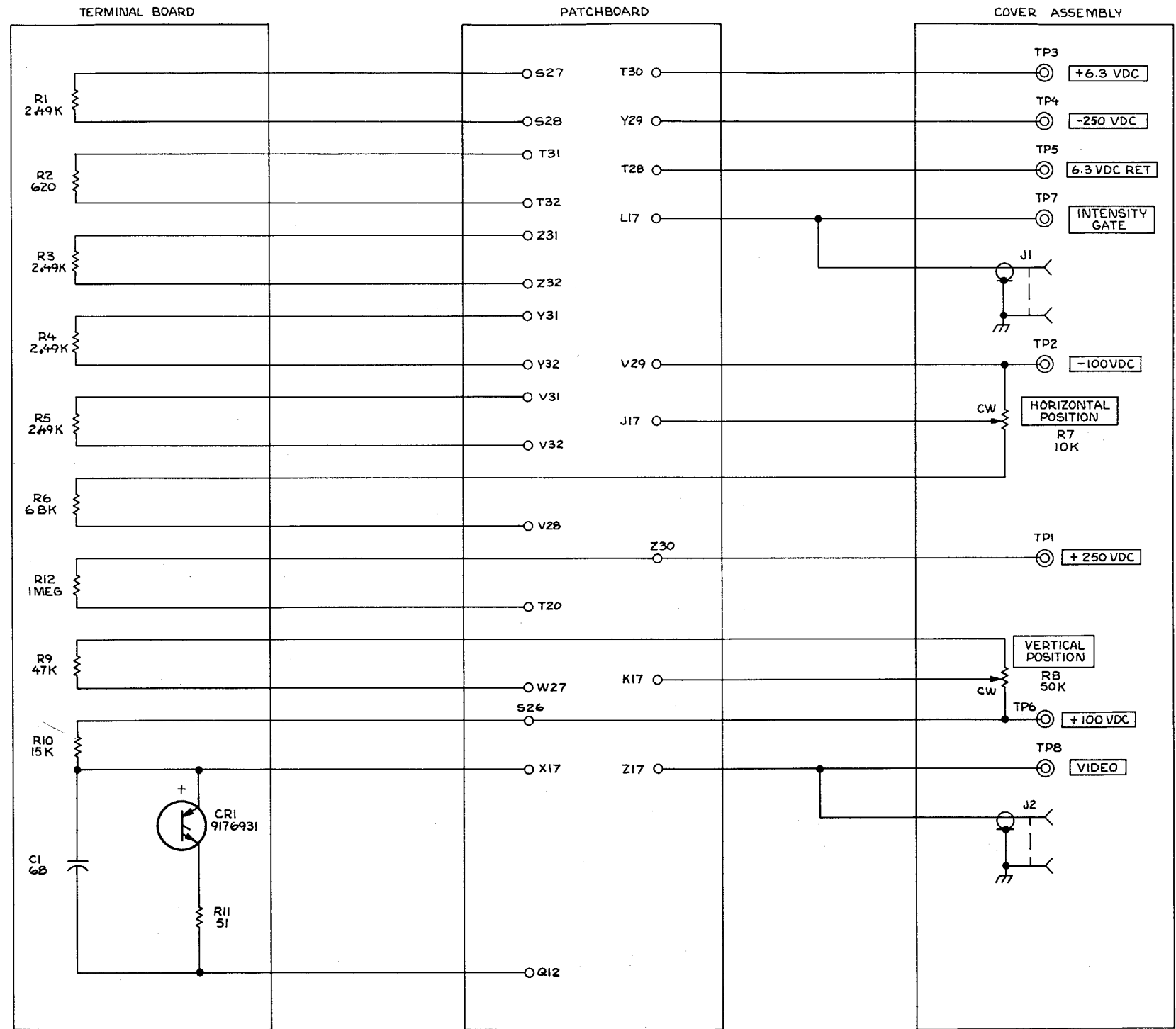

MI 69945A

Figure 3-20. Pb BCC-495B 10175145 (FG 1100)-schematic.

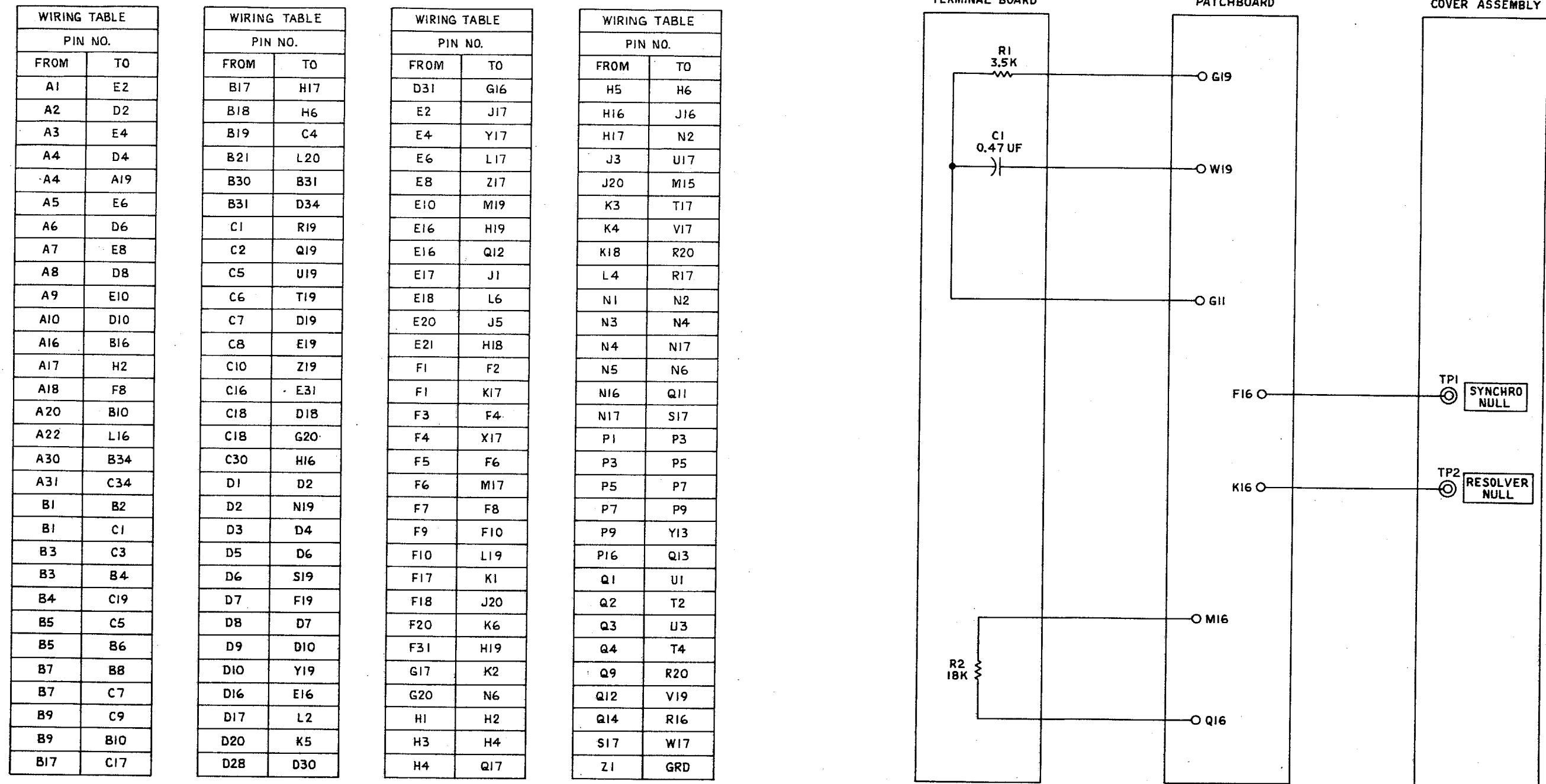

MI 69946A

Figure 3-21. Pb BCC-501 10110909 (FG 1085)-schematic.

WIRING TABLE	
PIN NO.	
FROM	TO
A1	V17
A2	J17
A3	J19
A4	U19
A5	C2
A5	T19
A7	Y19
A9	X19
A11	H19
A16	B21
A17	A19
A17	C17
A18	H4
A20	K9
A22	B16
B9	G18
B10	H18
B12	M20
B17	B19
B20	J9
B31	D34
C1	Y17
C3	C4
C3	T17
C5	C4
C5	C6
C8	K17
C16	E21
C19	A19
C19	E20
D17	D19
D18	J3
D20	J8
D21	Z19
D31	G20
E2	L3
E12	Q20

WIRING TABLE	
PIN NO.	
FROM	TO
E17	E19
E34	B19
F11	Z20
F16	J24
F18	J4
F19	F17
F31	H20
G3	W20
G4	X20
G5	Y20
G6	U20
G7	B16
G7	H5
G7	S20
G16	H16
G17	E16
G17	G19
G23	U28
H1	L18
H2	M18
H7	S18
H8	U18
H9	N18
H11	Z18
H12	W18
H13	X18
H14	Y18
H15	K18
H17	J19
H23	K23
H24	E20
H24	R23
J1	J2
J1	P20
J6	V20
J7	T18

WIRING TABLE	
PIN NO.	
FROM	TO
J10	J20
J11	R20
K16	W30
K19	K17
K24	J24
L1	L3
L1	N20
L16	M16
L17	R19
L19	R17
L23	H16
L23	Q23
L24	Q19
L24	V30
M1	X3
M1	M8
M2	M3
M2	V3
M4	M3
M4	M5
M6	M5
M17	S19
N1	N2
N1	T2
N3	N2
N3	N4
N5	N4
N5	N7
N9	N7
N9	N11
N12	W2
N16	P16
N16	Q12
N17	N19
P1	P2
P1	V1
P3	P2

WIRING TABLE	
PIN NO.	
FROM	TO
P3	P4
P5	P4
P5	P7
P9	P7
P9	P11
P12	T1
P17	P19
P18	J9
Q4	T4
Q10	F17
Q11	M16
Q13	R23
Q14	T15
Q16	E16
Q17	Q19
R18	J20
S17	U19
T20	T18
T28	V28
T33	T34
U17	C2
U29	V27
U33	U34
V18	J8
V29	V28
V29	W29
V33	V34
W16	T15
W19	J17
W33	W34
Y27	Y29
Y30	N19
Y33	Y34
Z29	D19
Z30	Y29
Z33	Z34
Z1	GRD

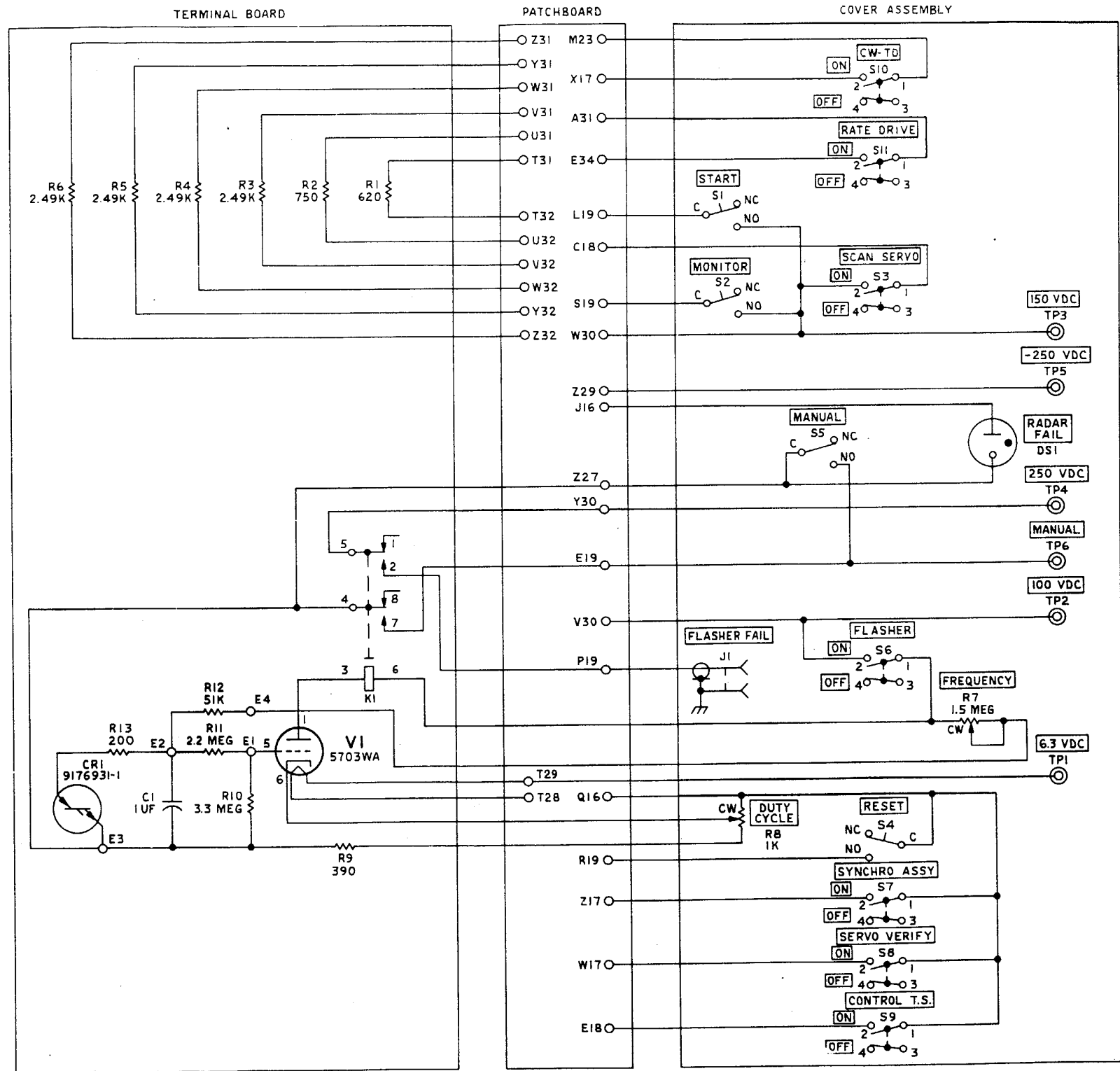

MI 69947

Figure 3-22. Pb BCC-503 10110936 (FG 1580)-schematic

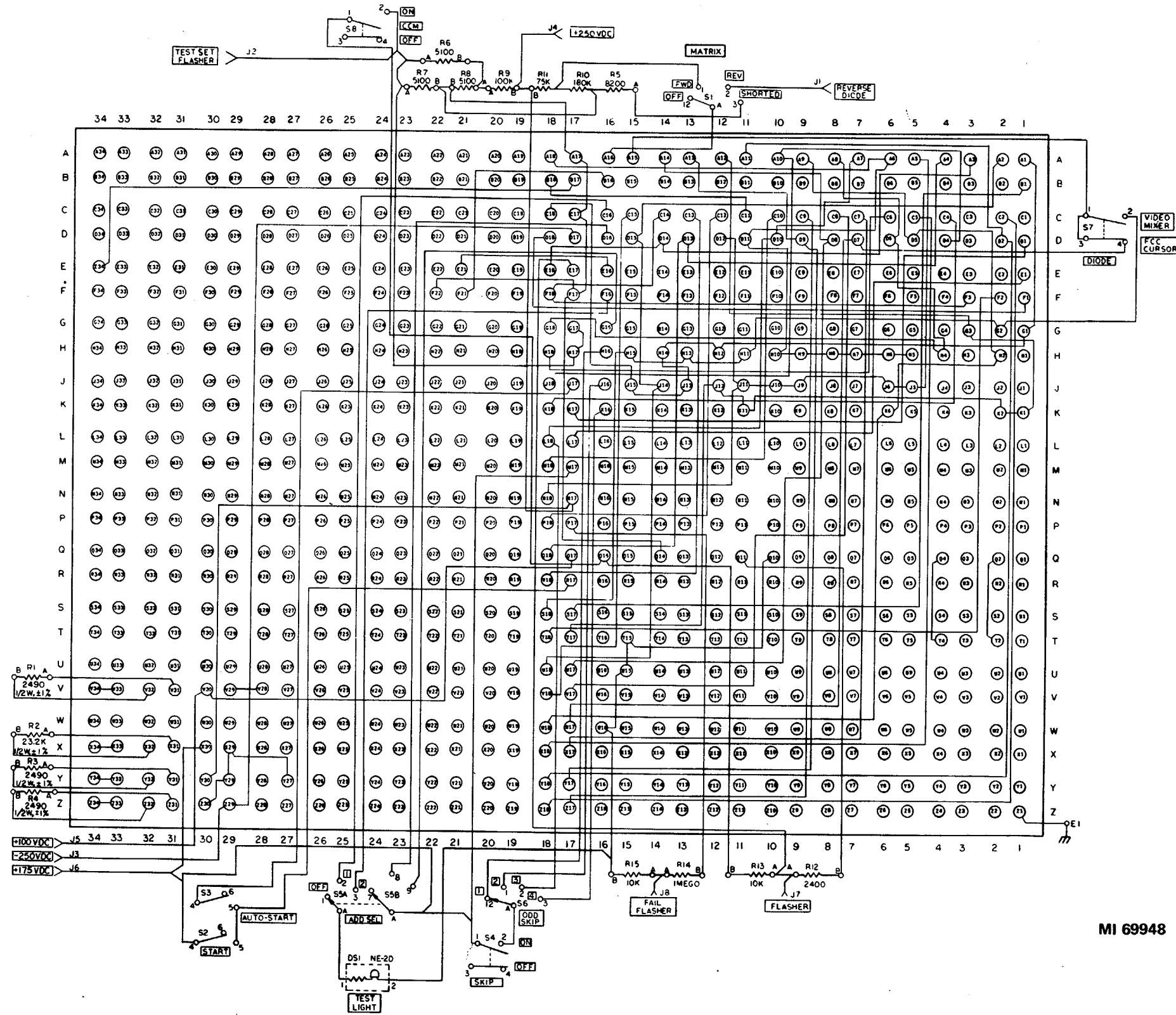

MI 69948

Figure 3-23. Pb BCC-596A 10675945 (FG 1650)-schematic

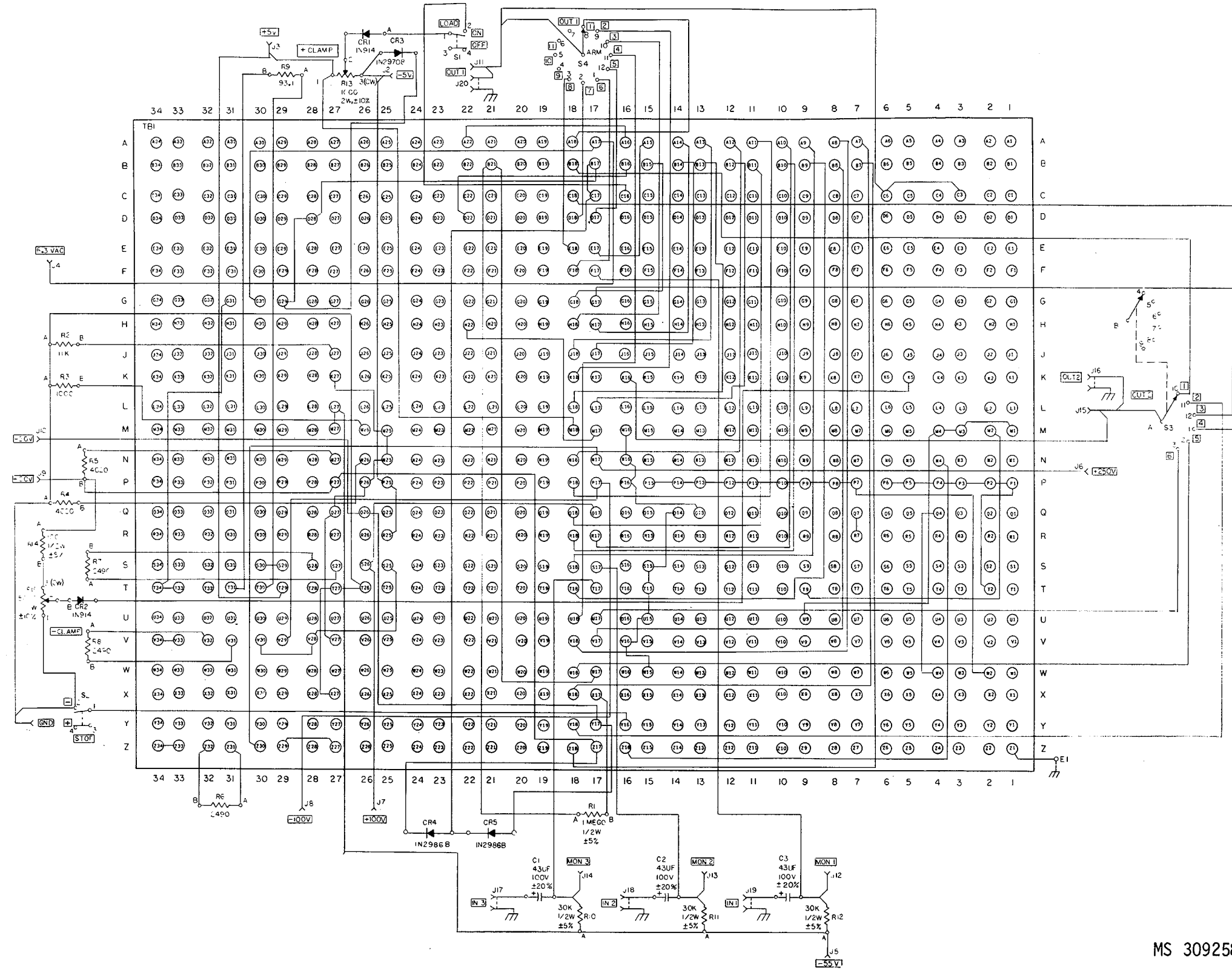

MS 309258

Figure 3-24. Pb BCC8-101A 11566007 (FG 1585)-schematic

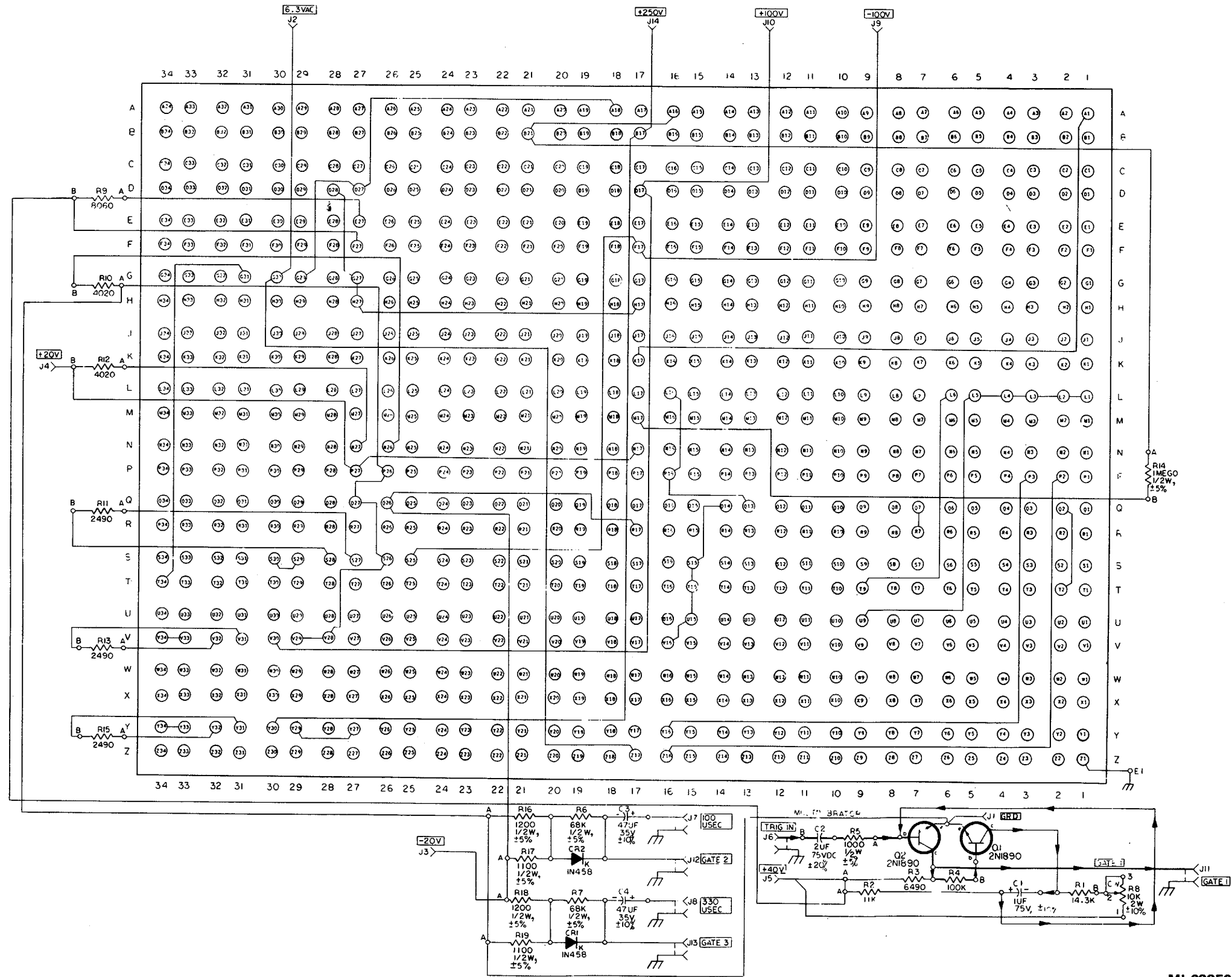
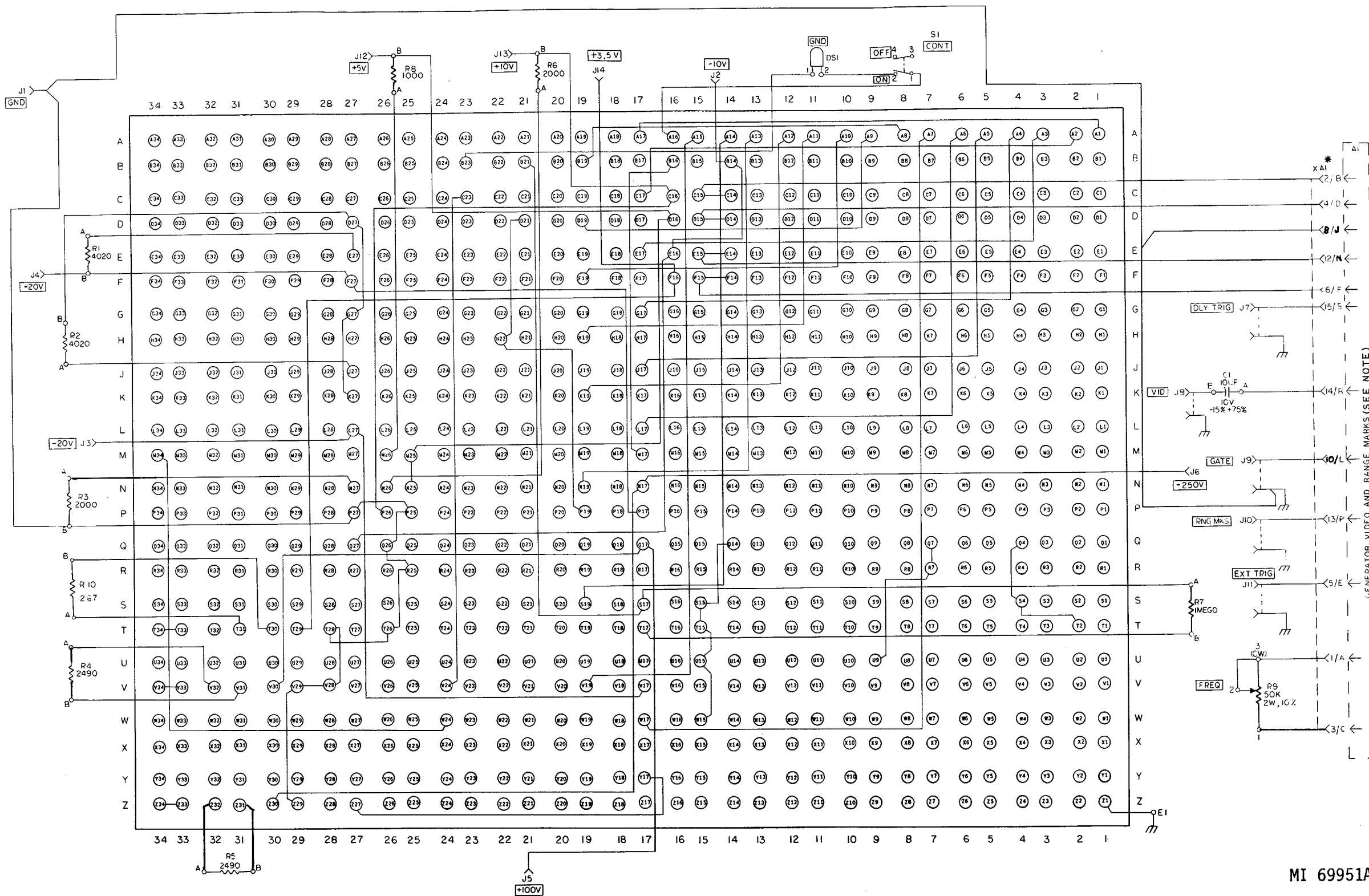

Figure 3-25. Pb BCCS-102 10670908 (FG 1590)-schematic.



MI 69951A

NOTE VIDEO AND RANGE MARKS GENERATOR (1) 1157093 REPLACES 10673973 BY ATTRITION.

Figure 3-26. Pb BCC8-103 10671754 (FG 1595) - schematic.

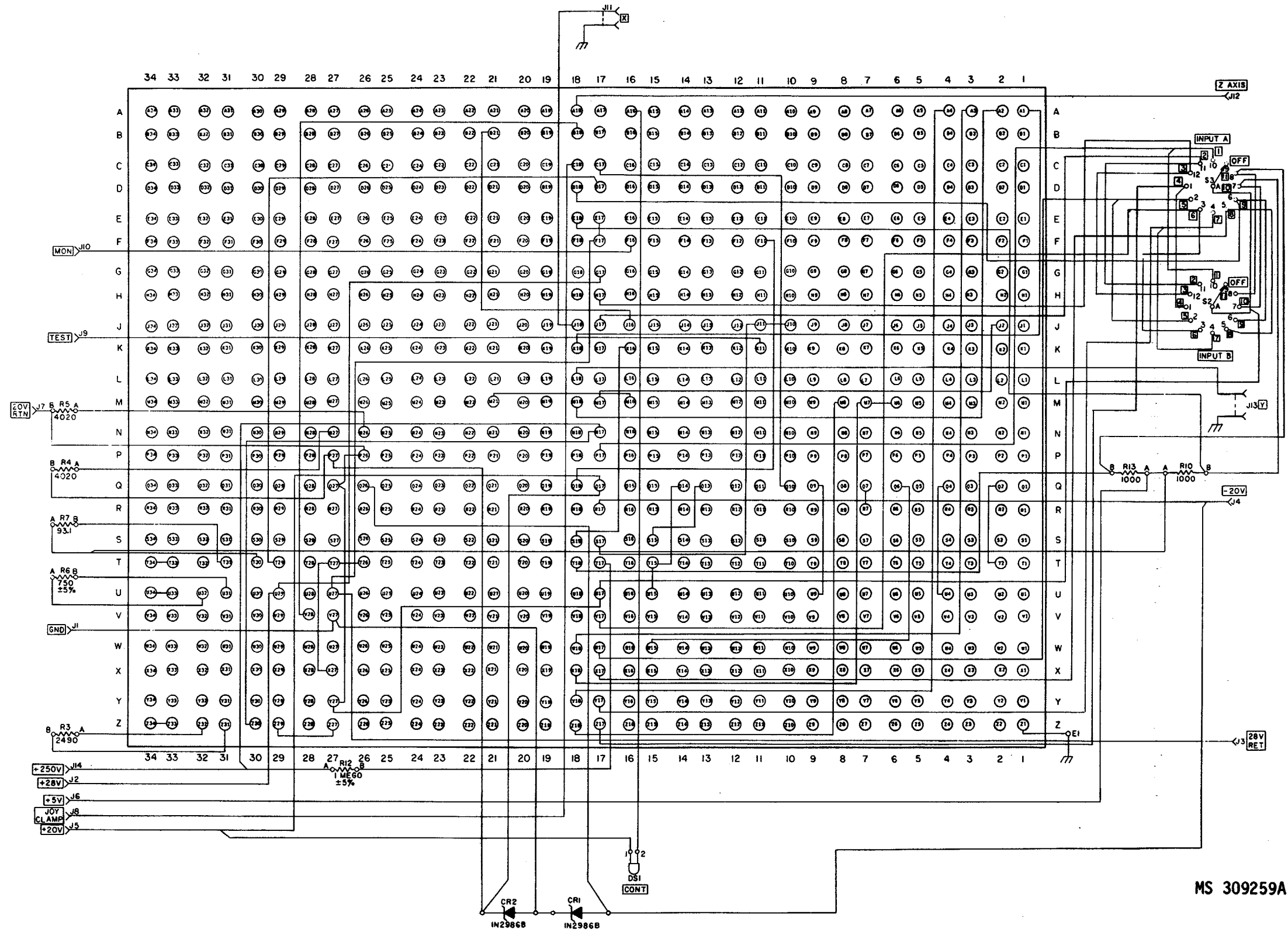

MS 309259A

Figure 3-27. Pb BCC8-104A 115666008 (FG 1600) - schematic.

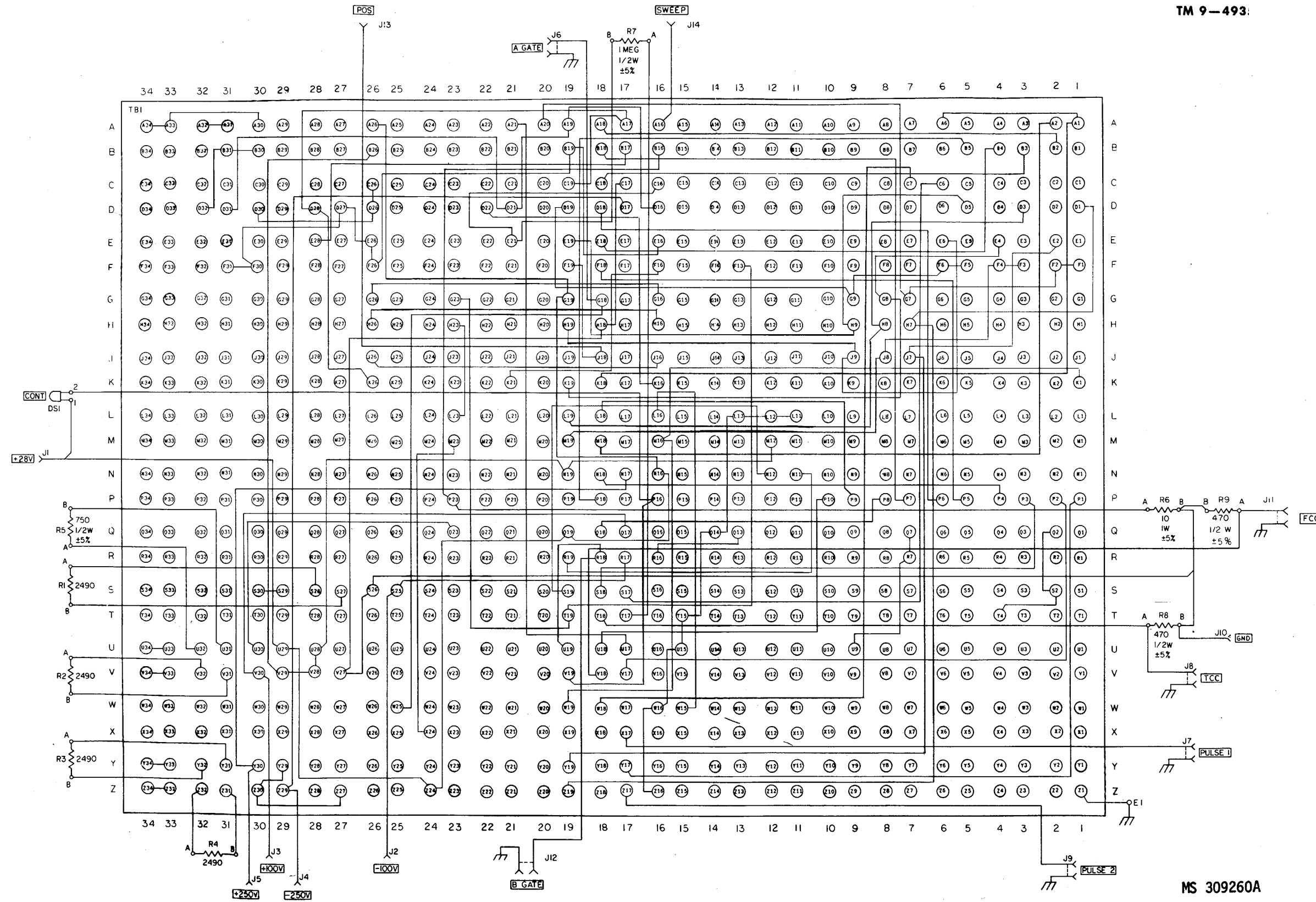

Figure 3-28. Pb BCC8-105A 11569625 (FG 1605) - schematic.

MS 309260A

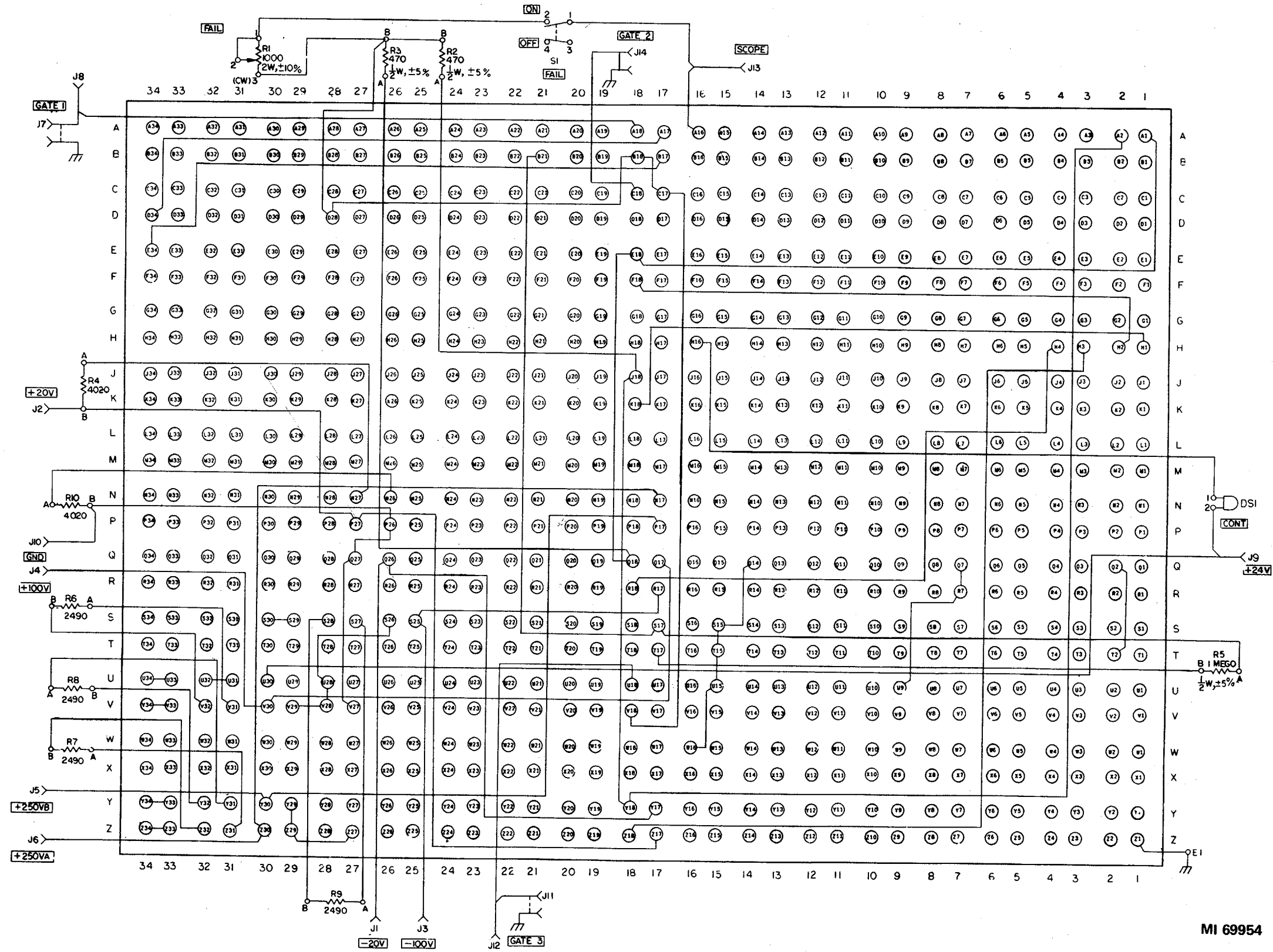
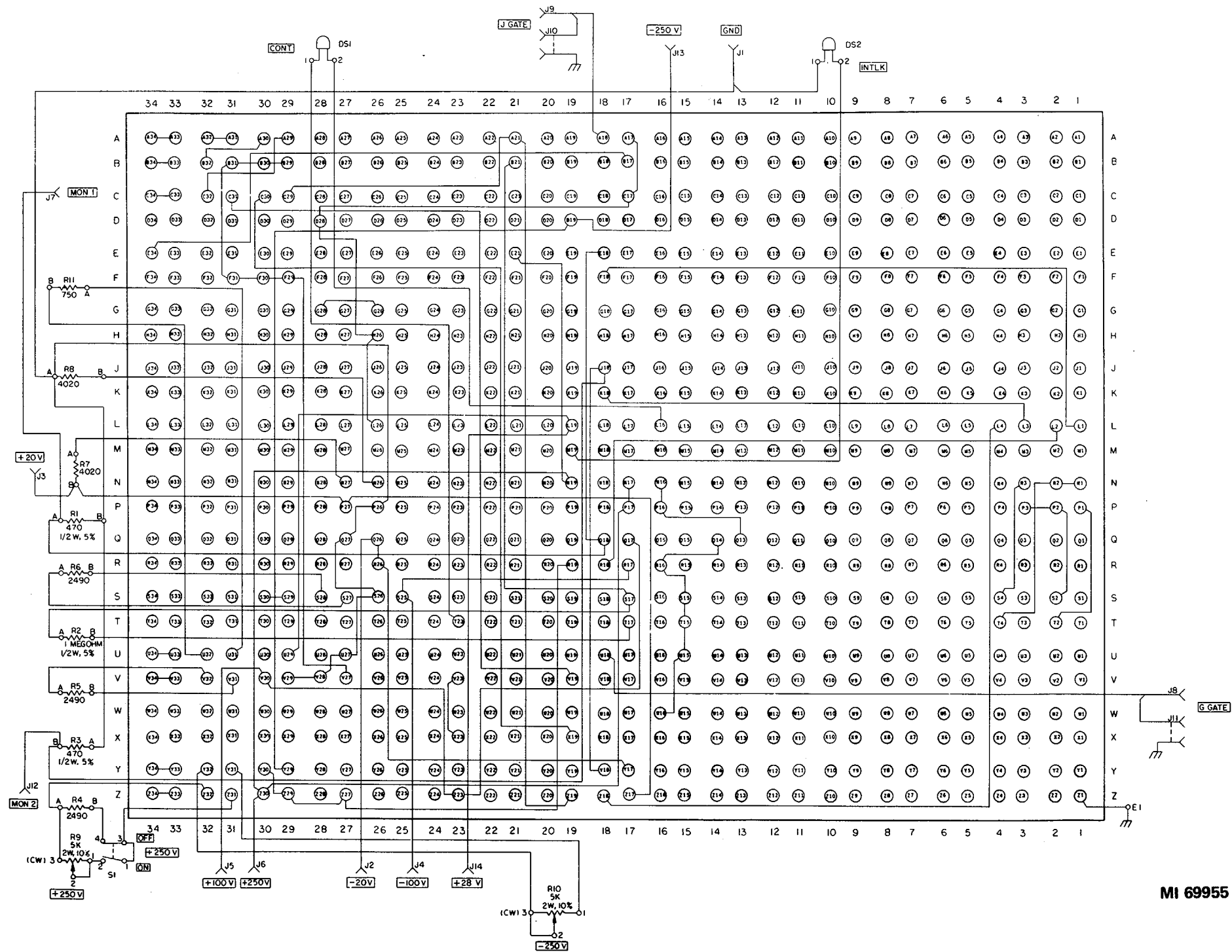

Figure 3-29. Pb BCC8-106 10671284 (FG 1610) - schematic.

MI 69954



MI 69955

Figure 3-30. Pb BCC8-107 10671173 (FG 1615) - schematic.

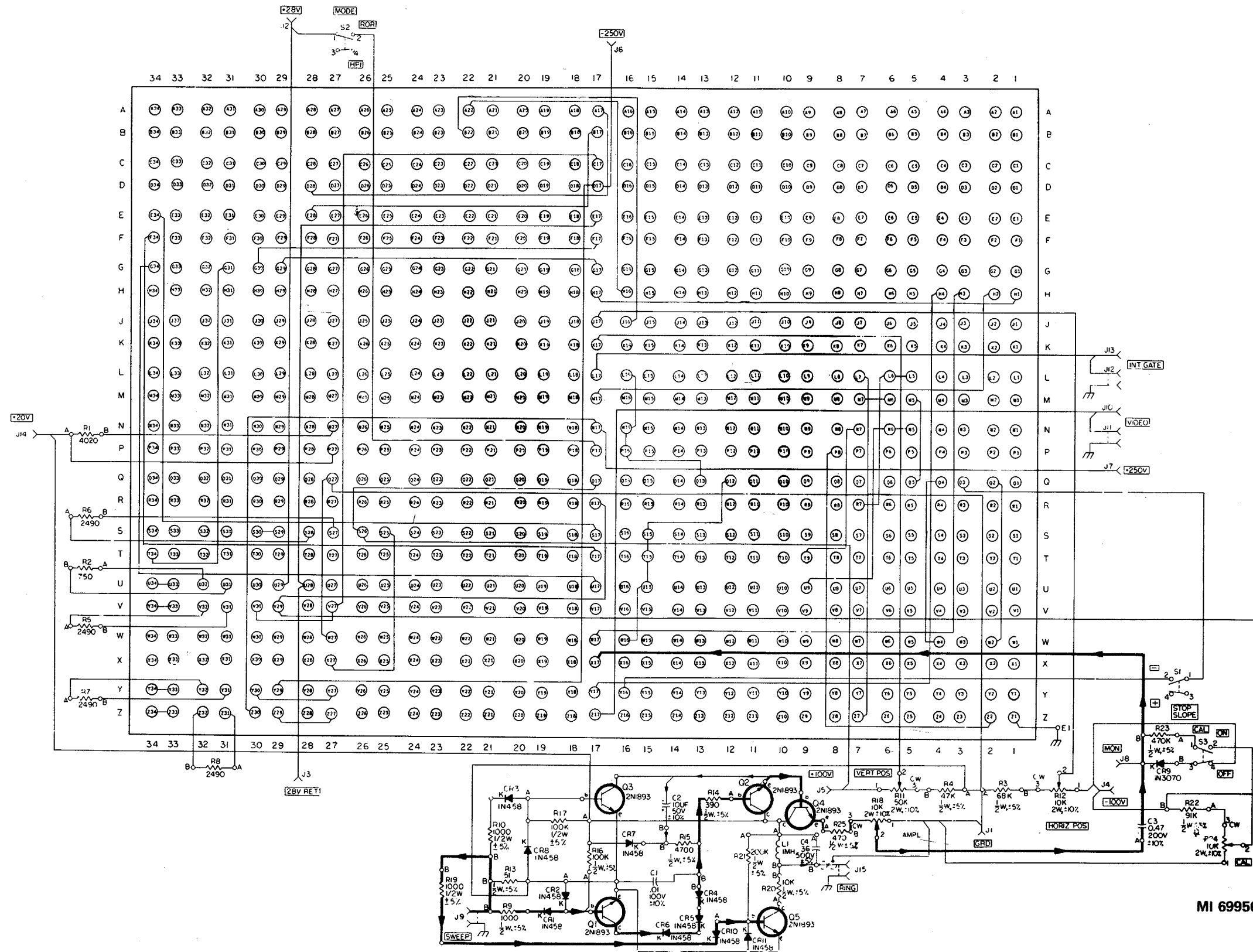
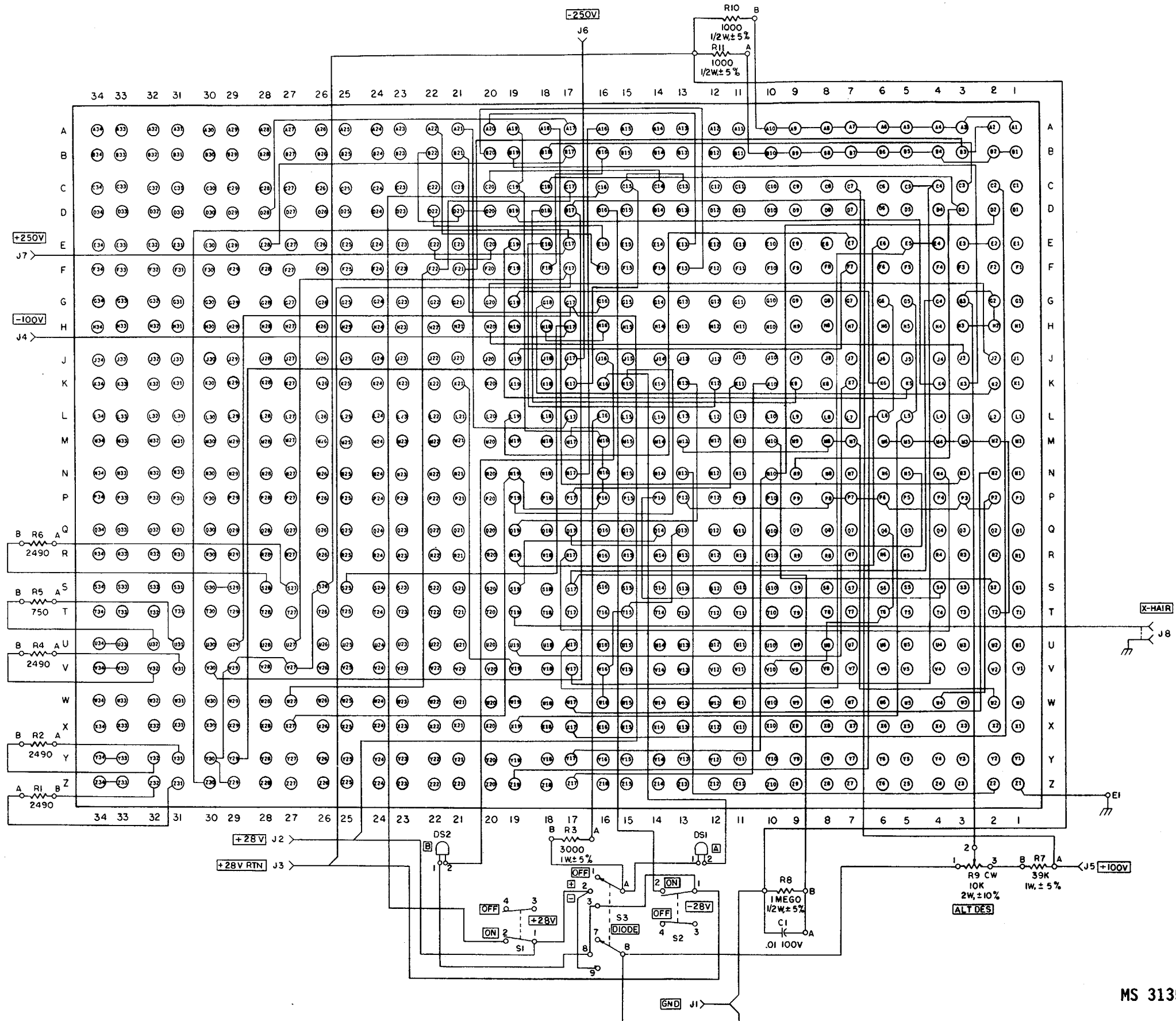
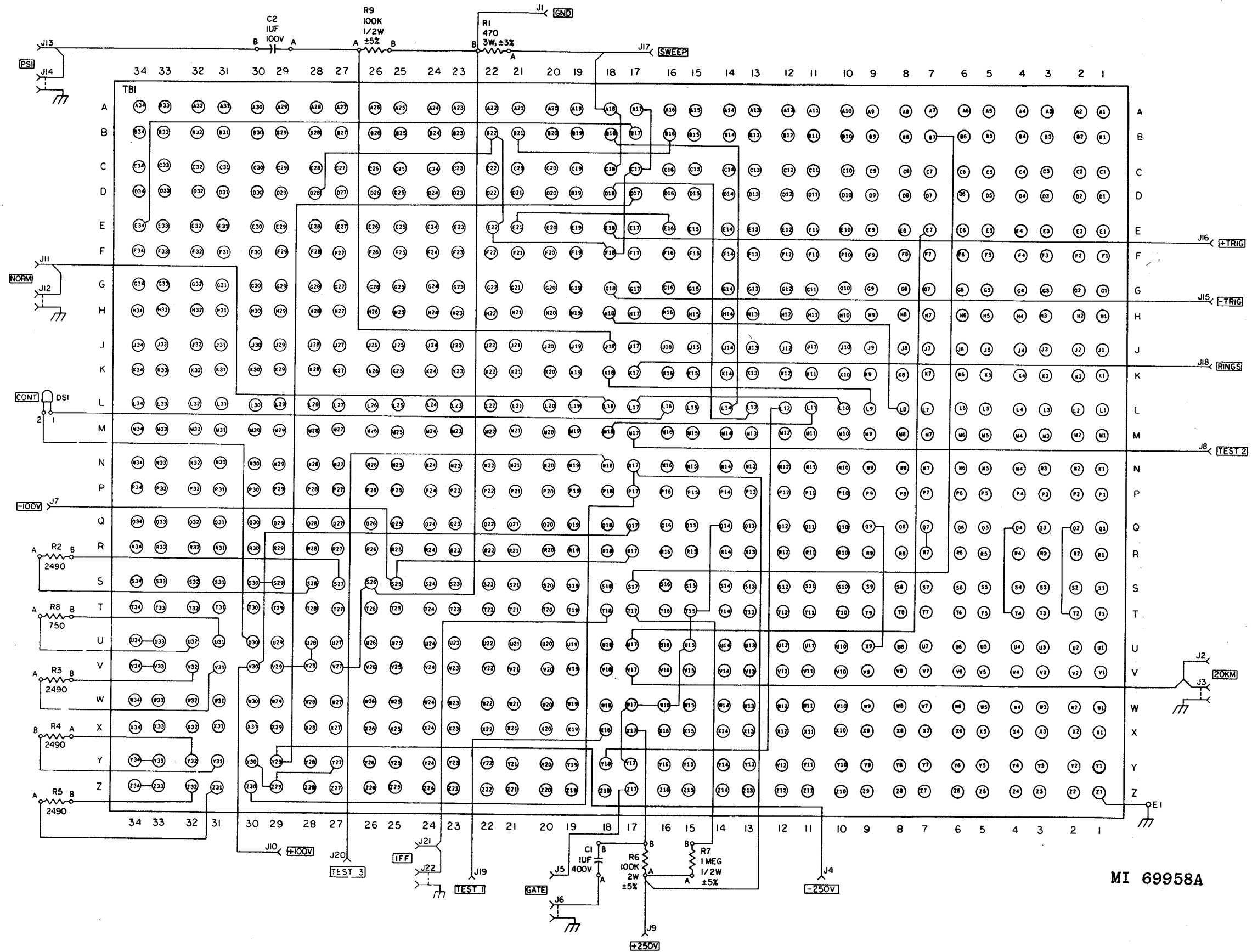

Figure 3-31. Pb BCC8-1012 10671755 (FG 1620) - schematic.



MS 313512A

Figure 3-32. Pb BCC8-1013A 11568008 (FG 1625) - schematic.



MI 69958A

Figure 3-33. Pb BCC8-1014 10670270 (FG 1630) - schematic.

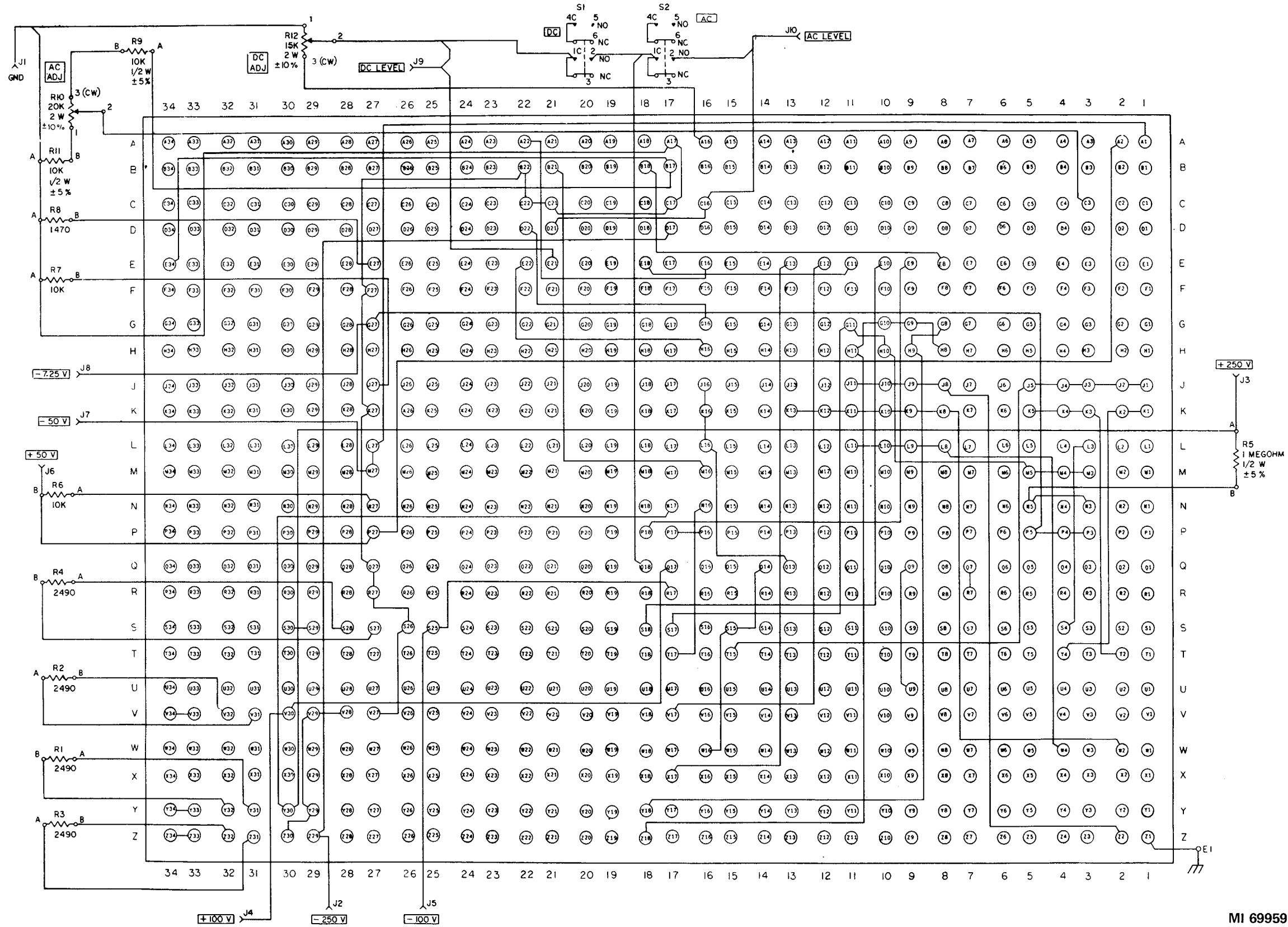
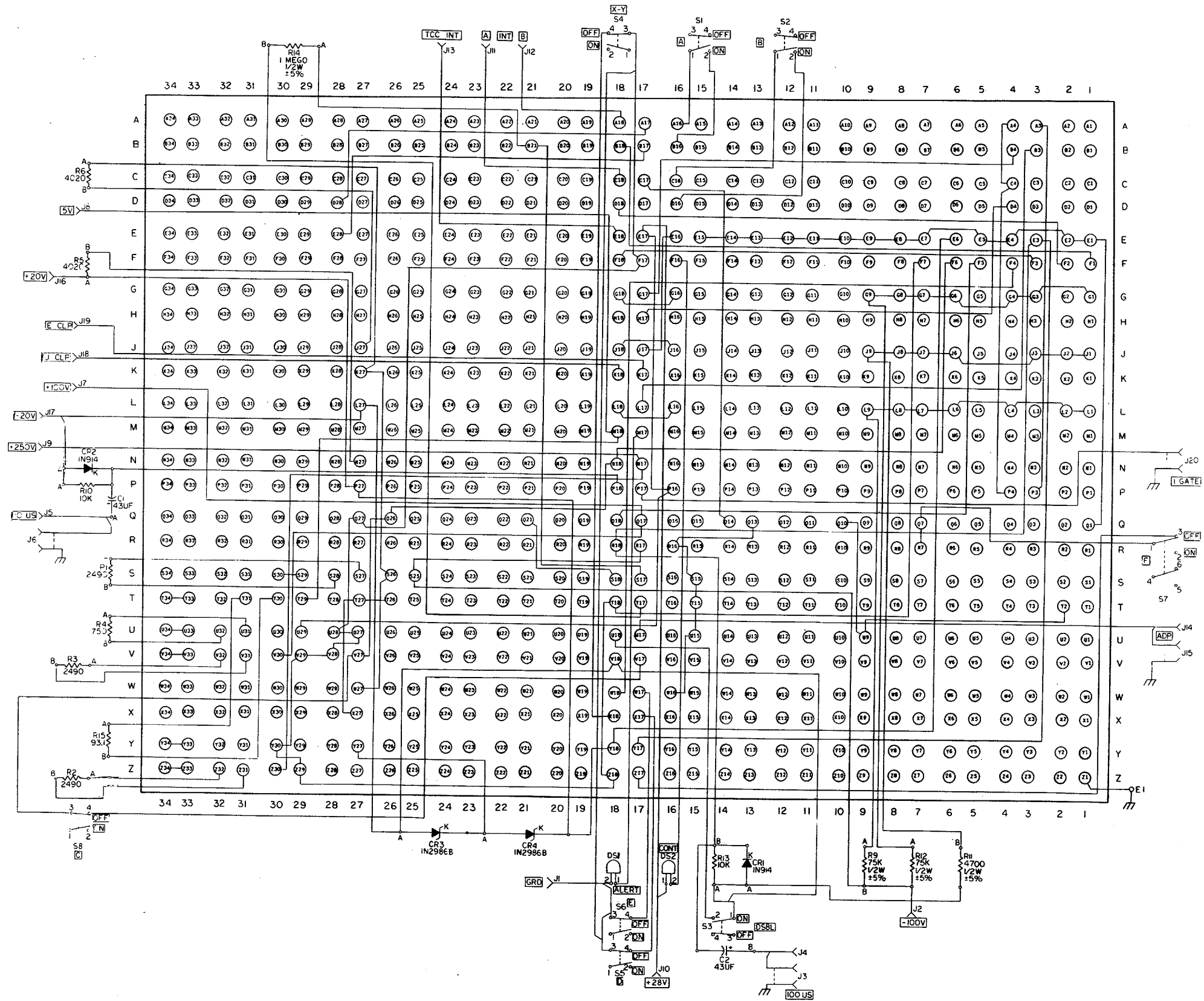

Figure 3-34. Pb BCC8-1015 10670262 (FG 1635) - schematic.

MI 69959



MS 309261A

Figure 3-35. Pb BCC8-1016A 11566009 (FG 1640) - schematic.

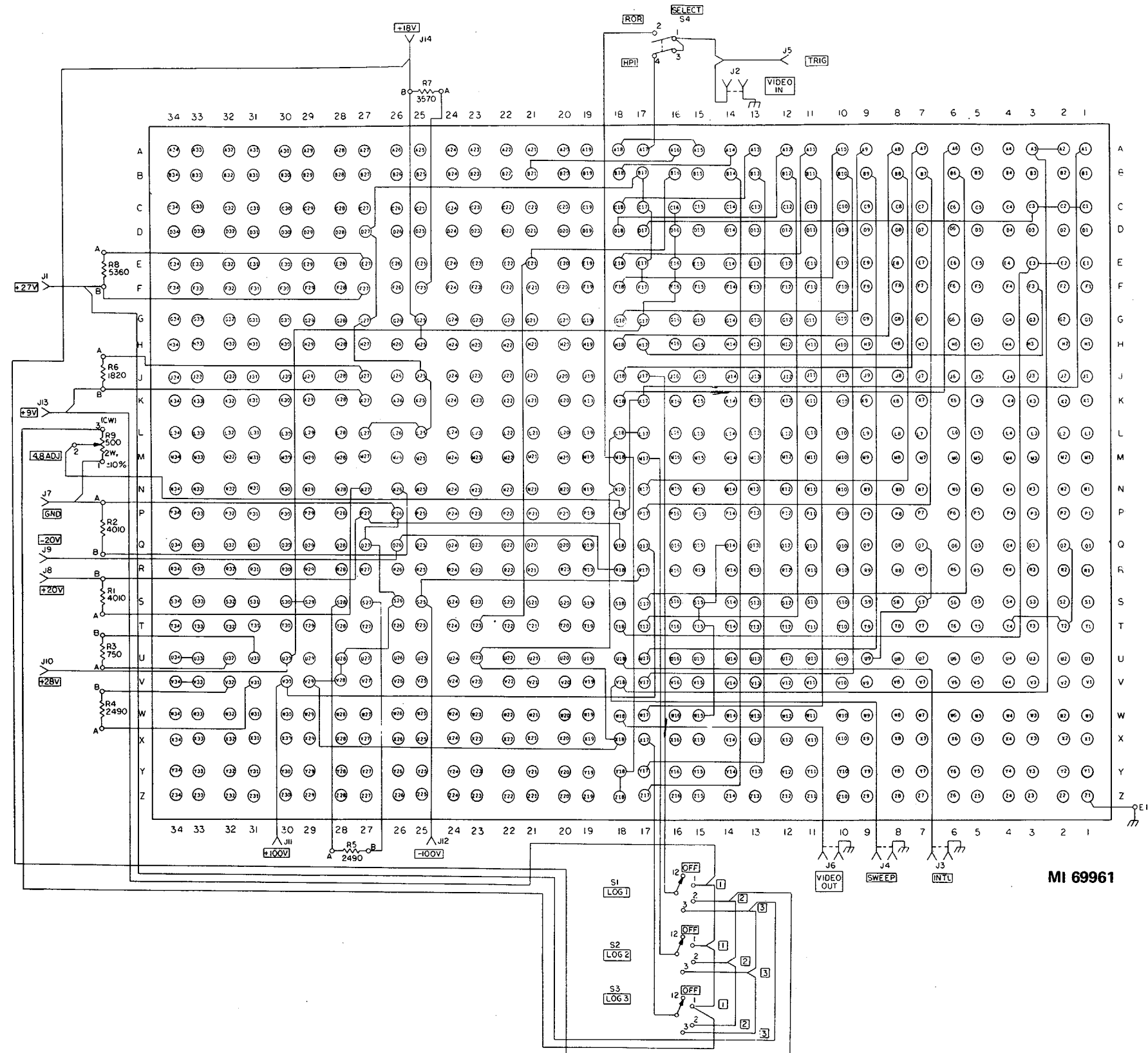
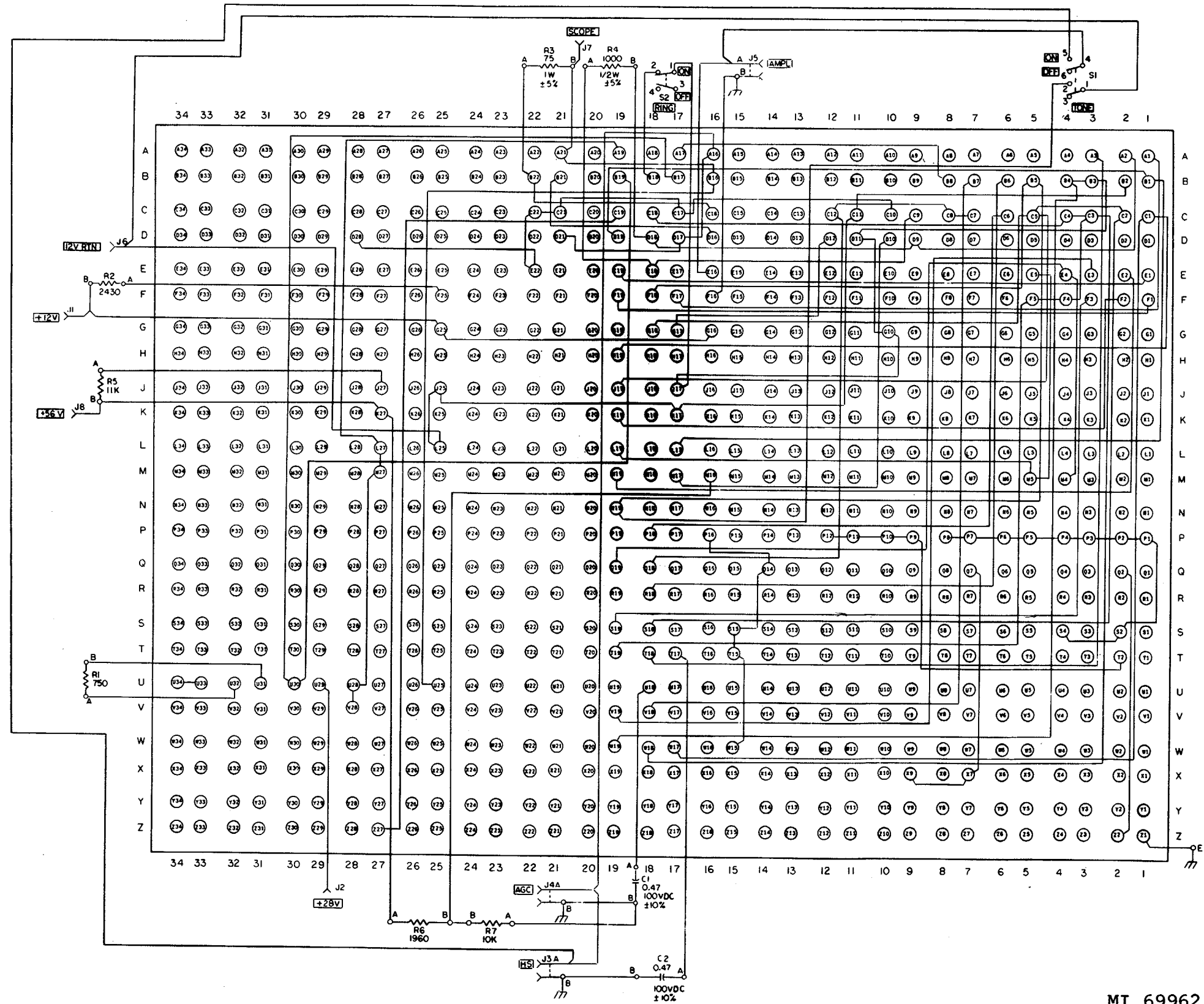

Figure 3-36. Pb BCC8-1810 10671758 (FG 1645) - schematic.
3-87



MI 69962

Figure 3-37. COMMO8-101 10675324 (FG 1735) - schematic.

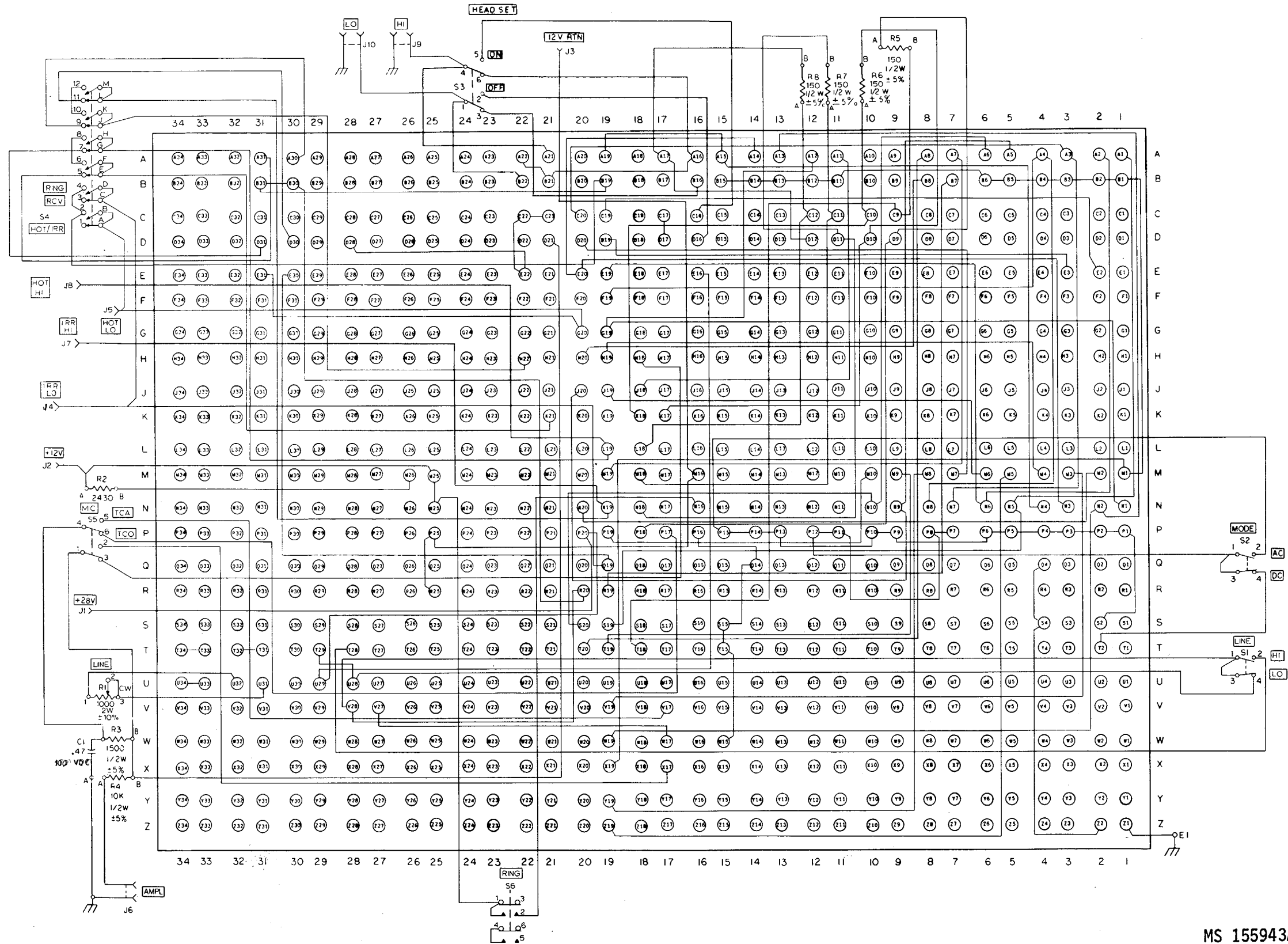
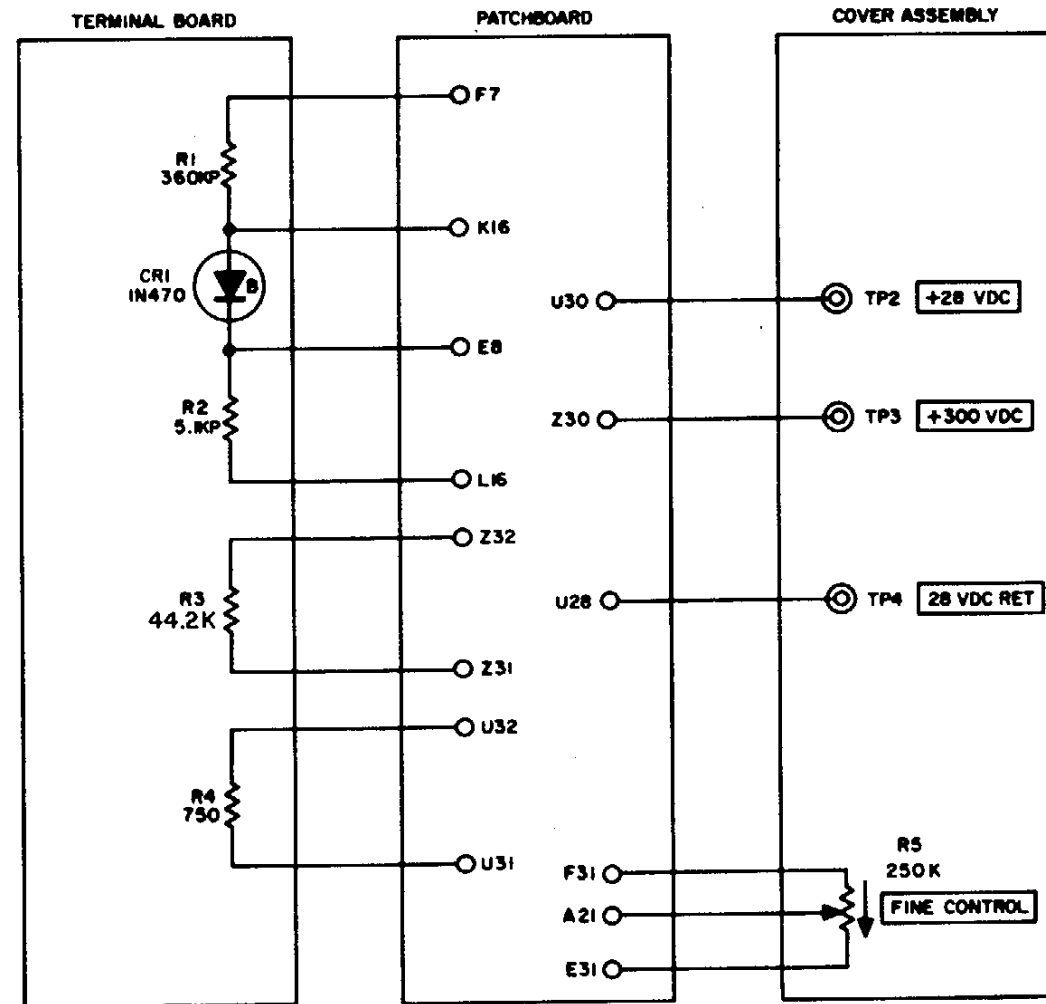

Figure 3-38. Pb COMMO8-102B 10288566 (FG 1740) - schematic.

MS 155943A

WIRING TABLE	
PIN NO.	
FROM	TO
A1	B1
A2	B2
A3	B3
A4	B4
A5	B6
A6	B5
A16	S18
A17	D29
A21	G2
A23	M18
A28	A29
A31	A32
A33	A34
A34	X18
B5	H4
B6	T18
B17	F29
B23	D24
B29	D28
B31	D32
D17	D24
D24	Z30
D34	Y18
E1	E2
E1	U8
E2	E3
E3	E4
E4	E5
E5	E6
E7	E8
E16	F21
E24	U8
F1	F2
F2	F3
F3	F4
F4	F5
F5	F6
F8	M8
F7	F8
F16	F22

WIRING TABLE	
PIN NO.	
FROM	TO
F31	H2
G1	H1
G2	H3
G3	H2
G3	H4
G4	H3
G5	H5
G6	H6
G16	K17
H16	L17
J4	W18
J6	U29
K7	L8
K8	U17
L7	J16
L8	V27
N1	S1
N2	N3
N2	T1
N4	U1
N5	N6
N5	W1
N16	Q10
P1	P6
P2	P3
P3	P4
P4	P5
P5	Y6
P6	X6
P7	P8
P7	R6
P16	Q11
Q2	S2
Q13	T5
R16	Q14
U17	U27
U33	U34
V17	W27
Z27	Z29
Z33	Z34
Z1	GRD



MI 69965A

Figure 3-40. Pb CWR-432 9195750 (FG 1110) - schematic.

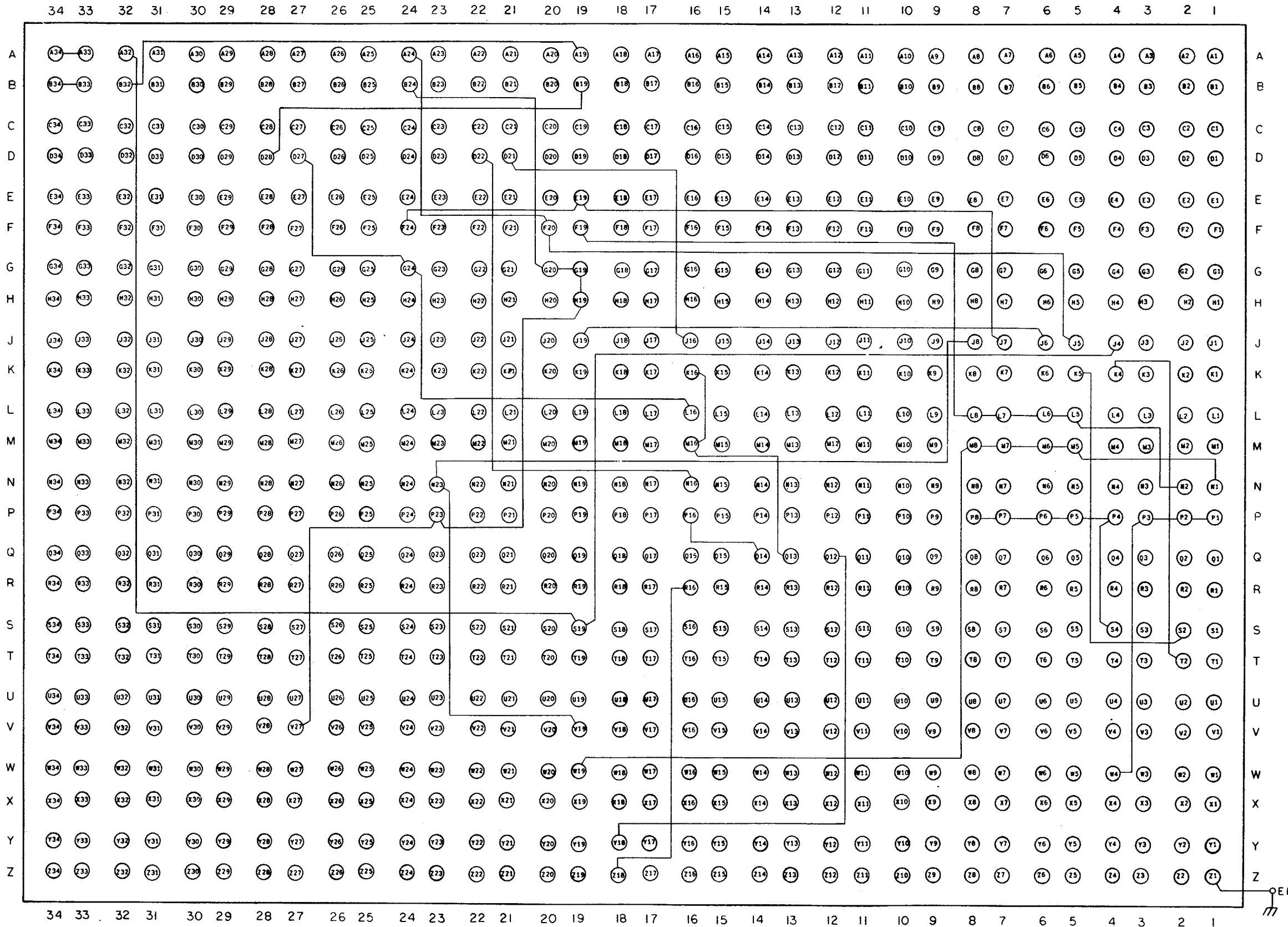

MI 69966

Figure 3-41. CWR-435A 10670540 (FG 1115) - schematic.

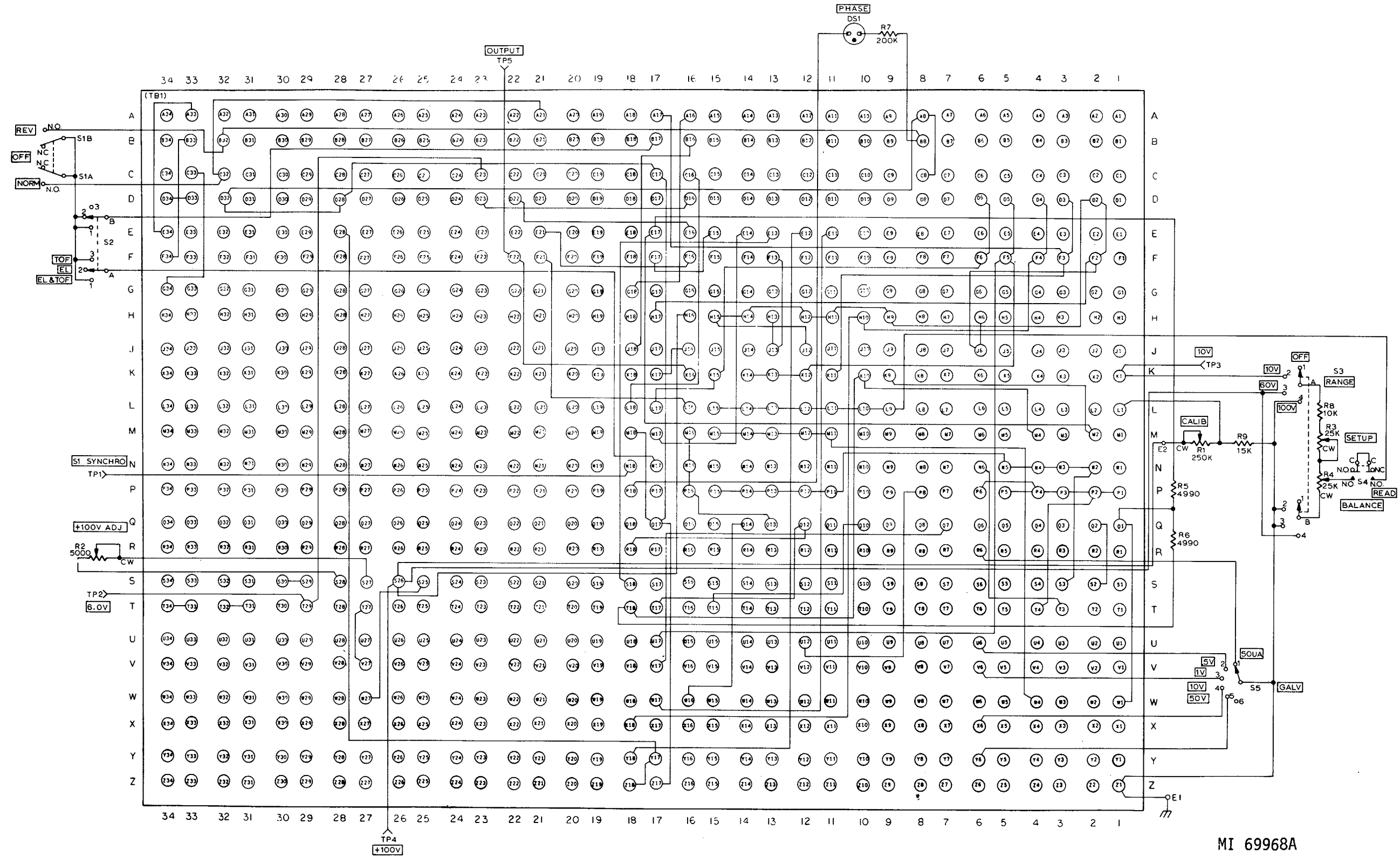

MI 69968A

Figure 3-42. Pb CWR-462B 10676886 (FG 1120) - schematic.

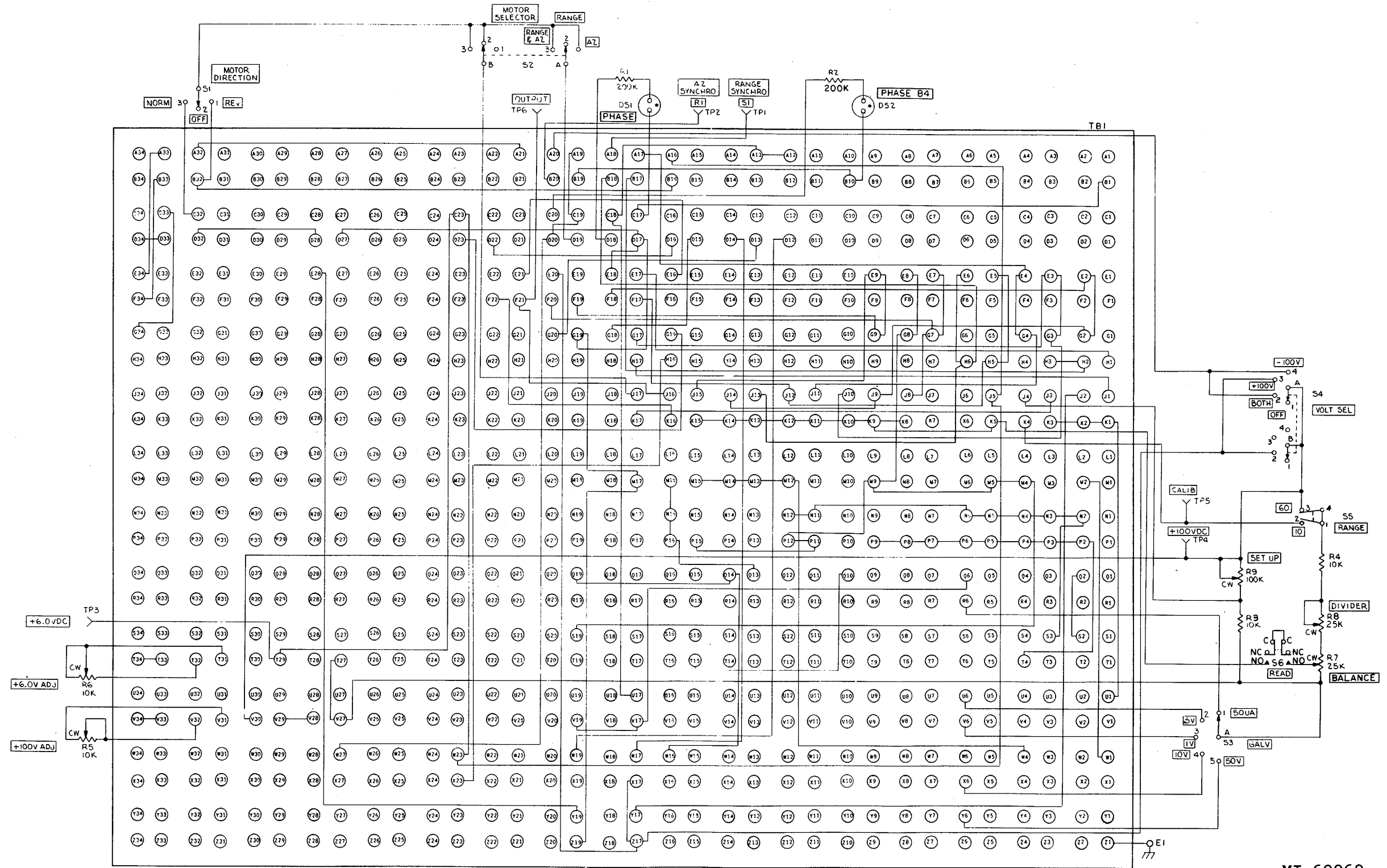

MI 69969

Figure 3-43. Pb CWR-463A 10179011 (FG 1125) - schematic.

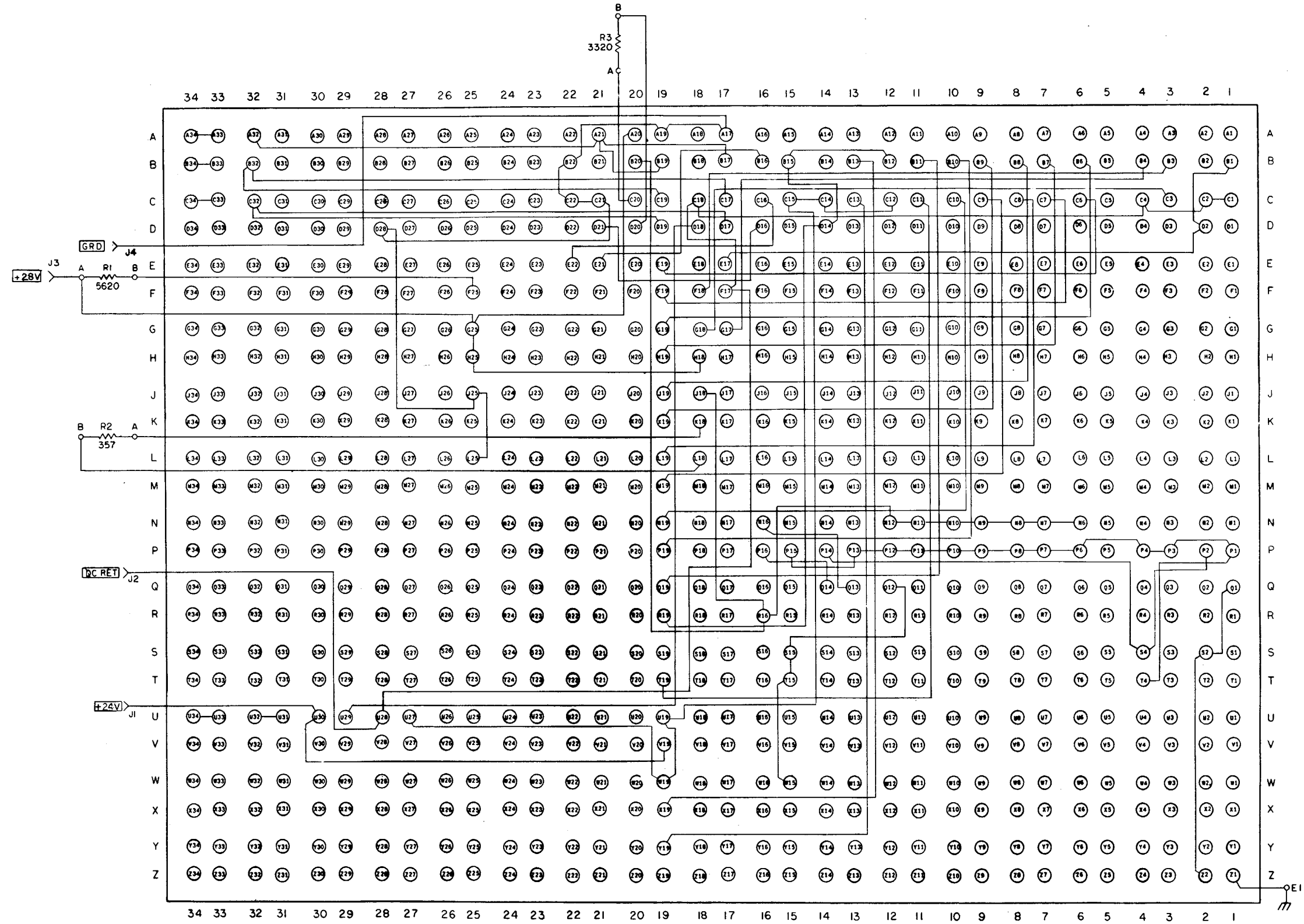

MI 69970

Figure 3-44. Pb CWR8-102 10670530 (FG 1655) - schematic.

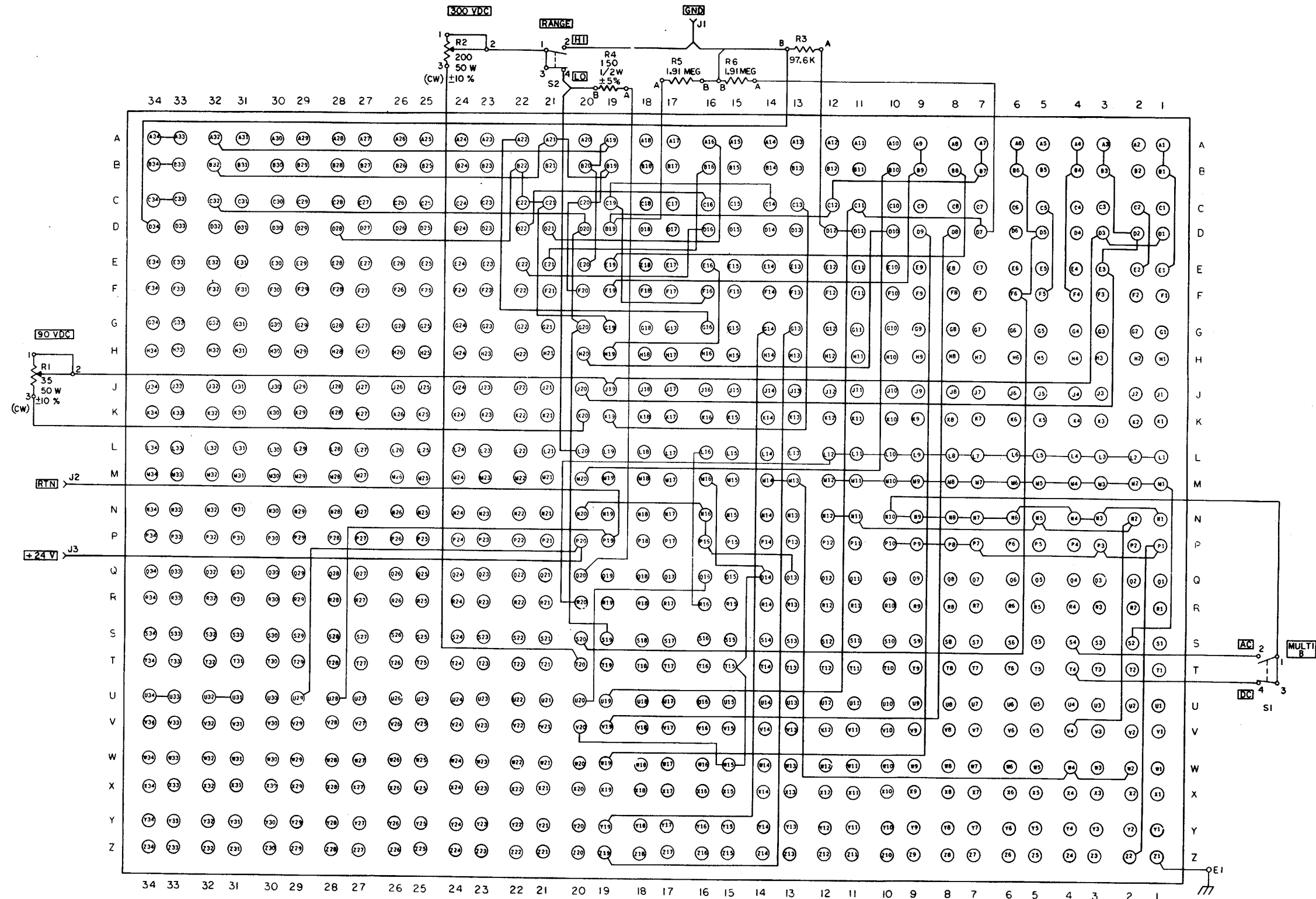

MI 69971

Figure 3-45. Pb CWR8-103 10670258 (FG 1645) - schematic.

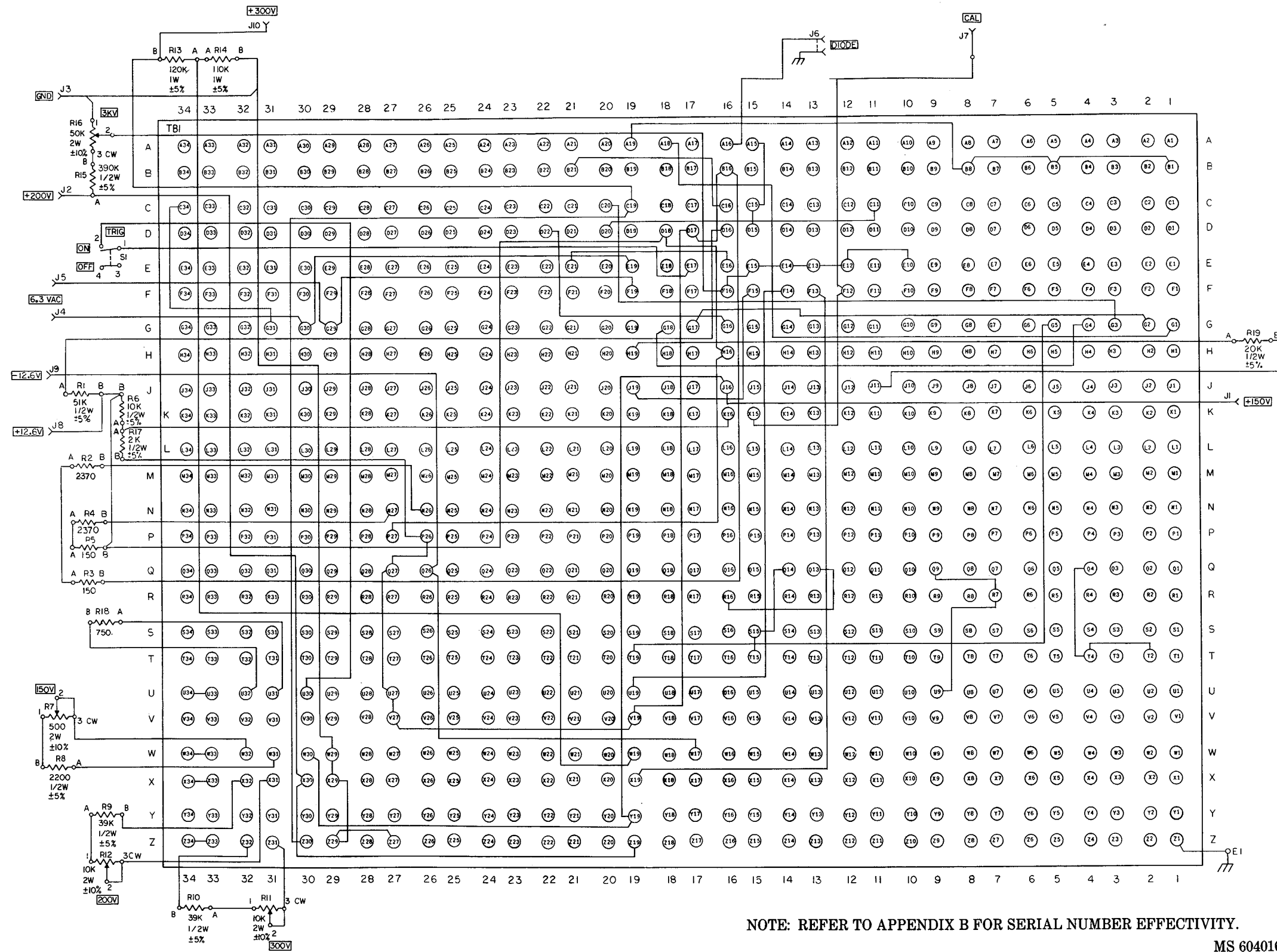

NOTE: REFER TO APPENDIX B FOR SERIAL NUMBER EFFECTIVITY.

MS 604010

Figure 3-45.1. Pb CWR8-107A 13233639* (AQ) (see note) (FG 1670) - schematic.

3-96.1/(3-96.2 blank)

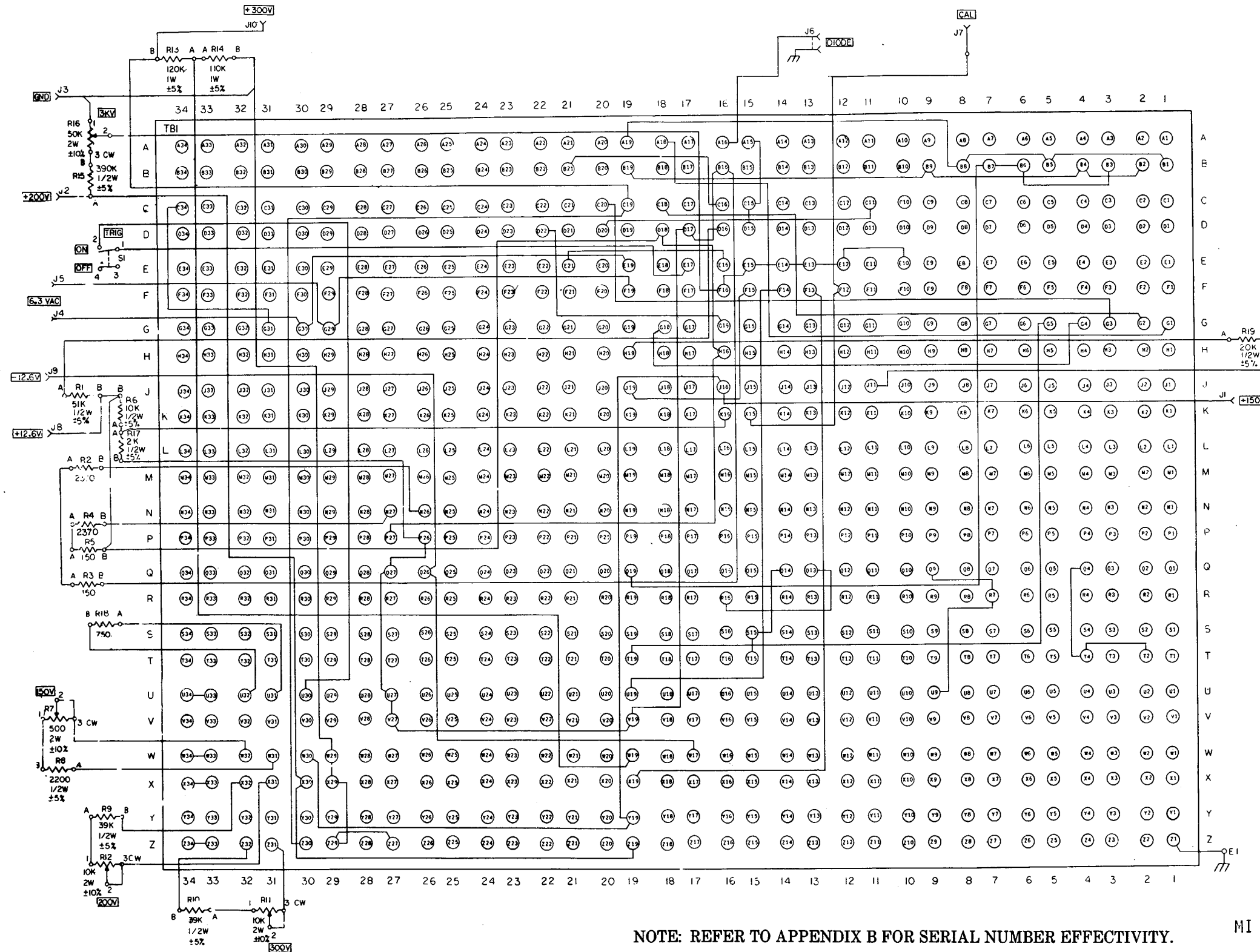

NOTE: REFER TO APPENDIX B FOR SERIAL NUMBER EFFECTIVITY.

MI 69973A

Figure 3-46. Pb CWR8-107 10670245* (AP) (see note) (FG 1670) - schematic.

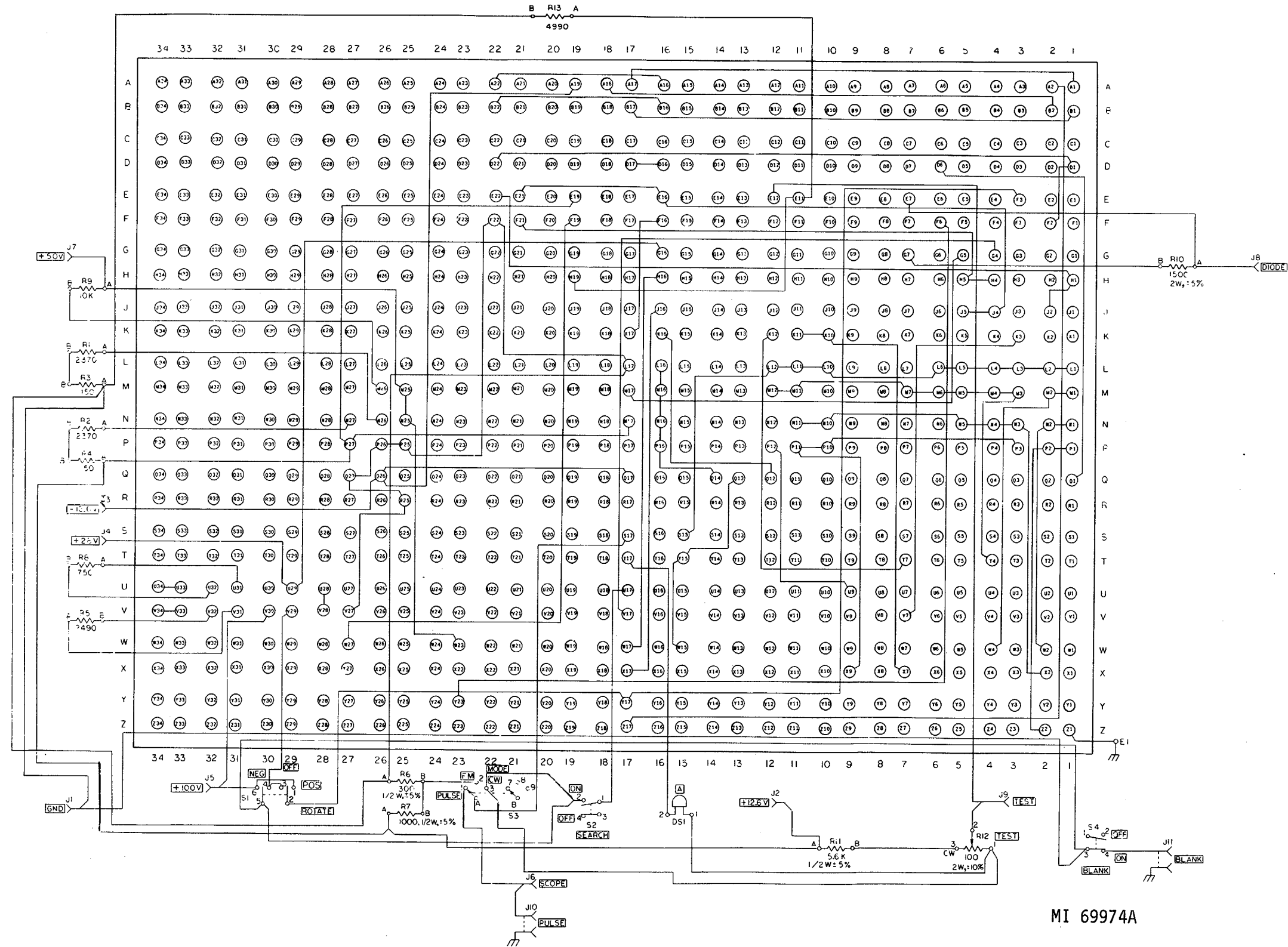

MI 69974A

Figure 3-47. CWR8-108 10671589 (FG 1675) - schematic.

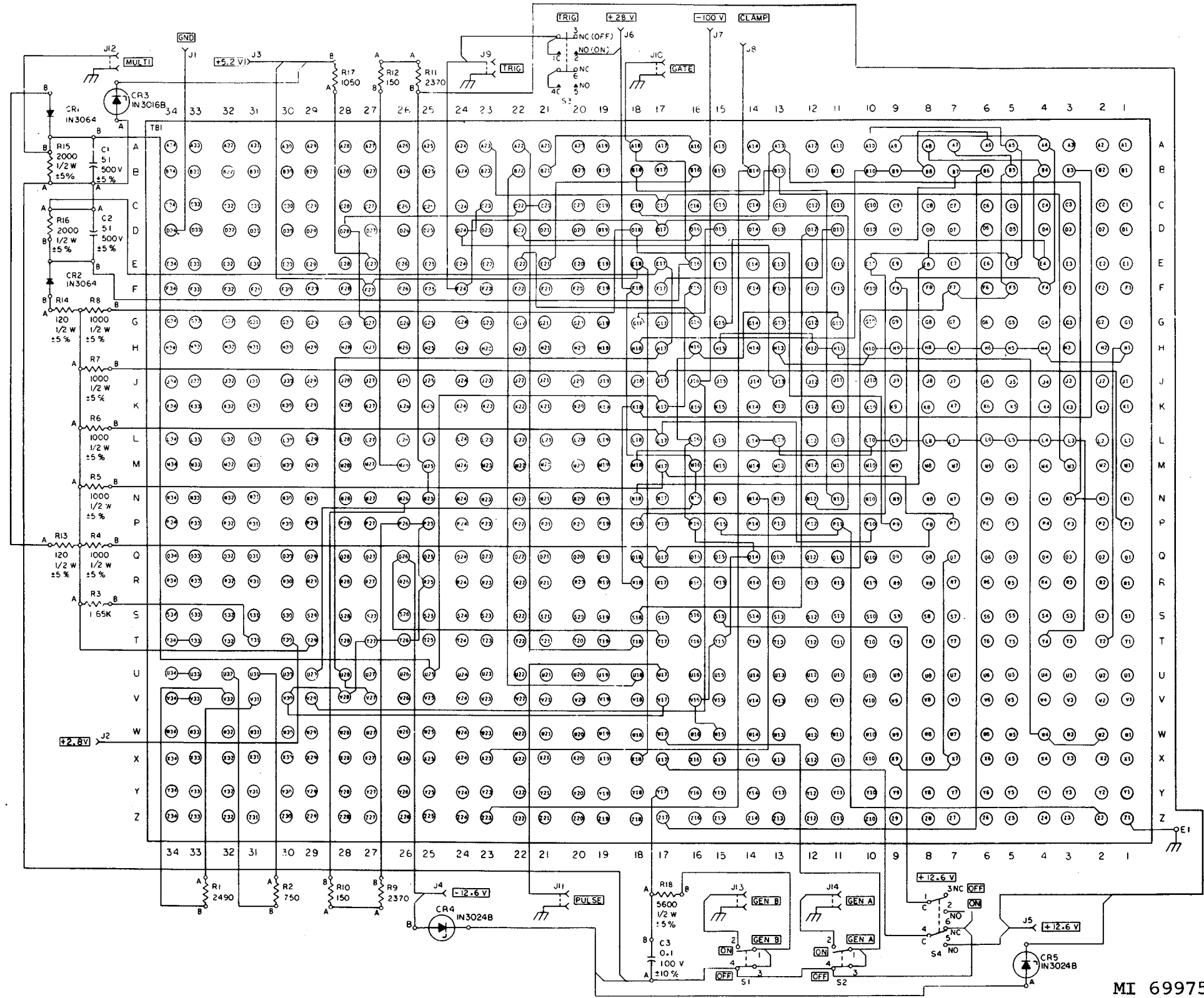

MI 69975

Figure 3-48. Pb CWR8-109 10670249 (FG 1680) - schematic

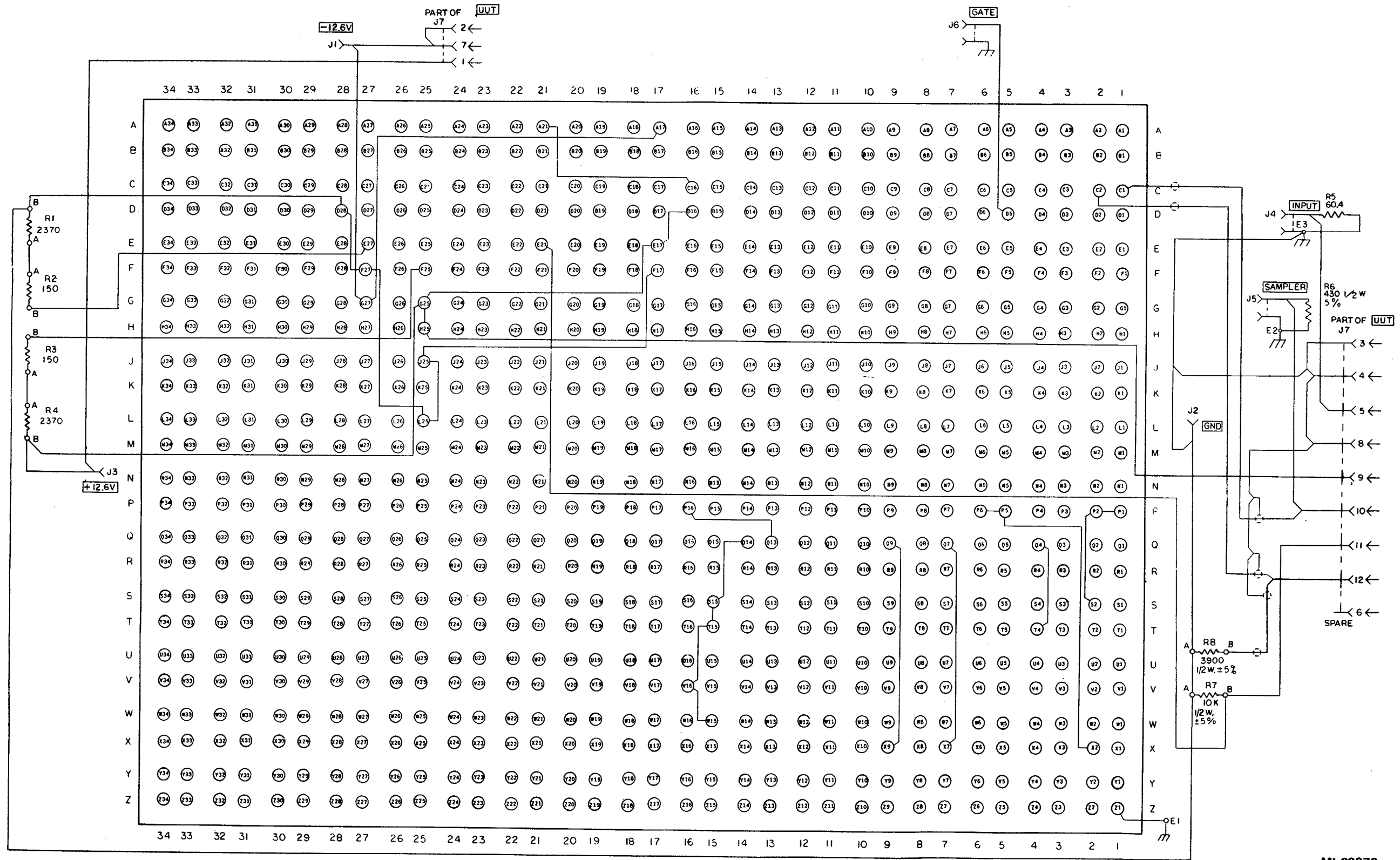

MI 69976

Figure 3-49. Pb CWR8-1010 10671625 (FG 1685) - schematic

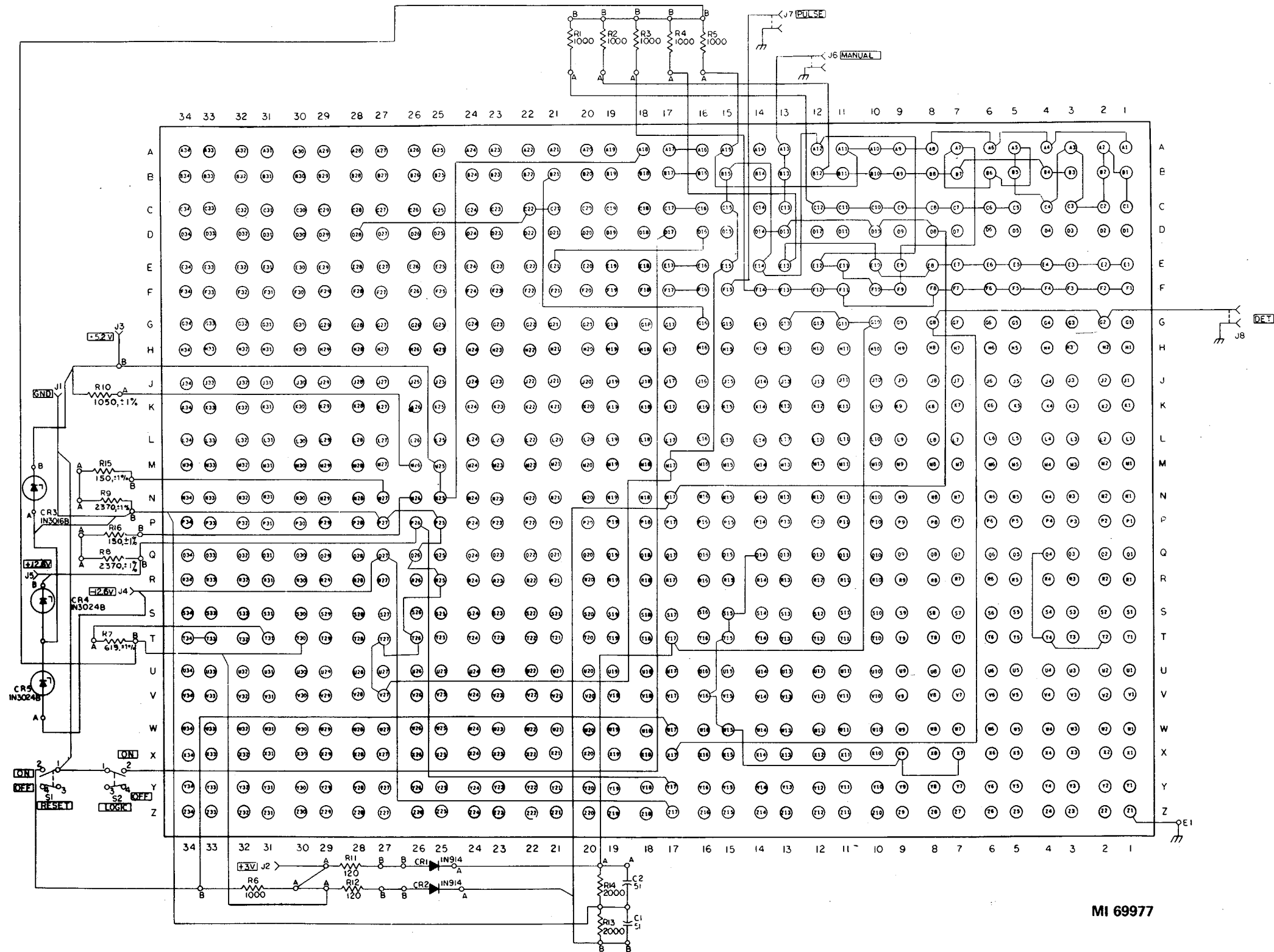

MI 69977

Figure 3-50. Pb CWR8-1011 10671165 (FG 1690) - schematic.

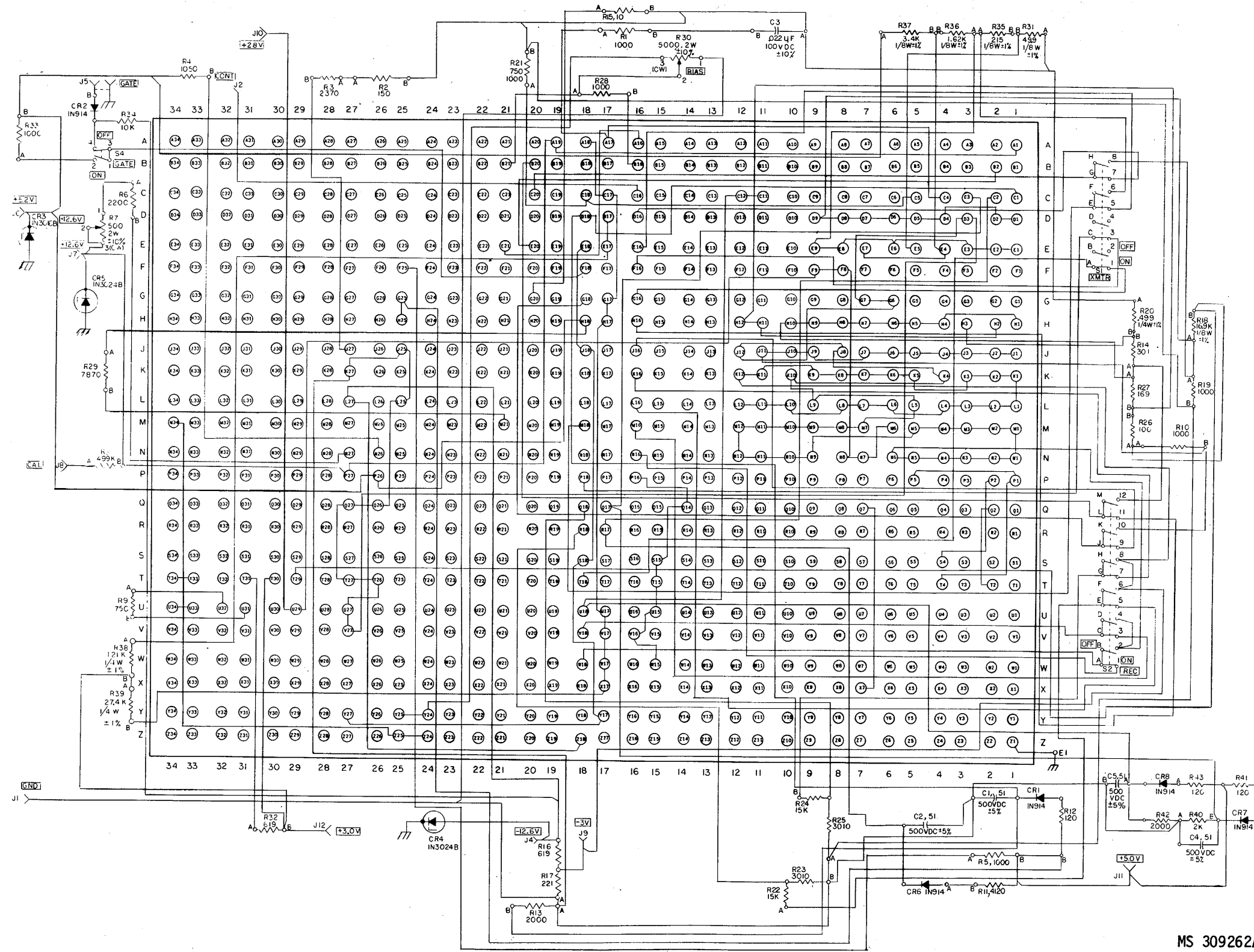

Figure 3-51. Pb CWR8-1012A 11566012 (FG 1695)—schematic.

MS 309262A

Figure 3-51. Pb CWR8-1012A 11566012 (FG 1695) - schematic.

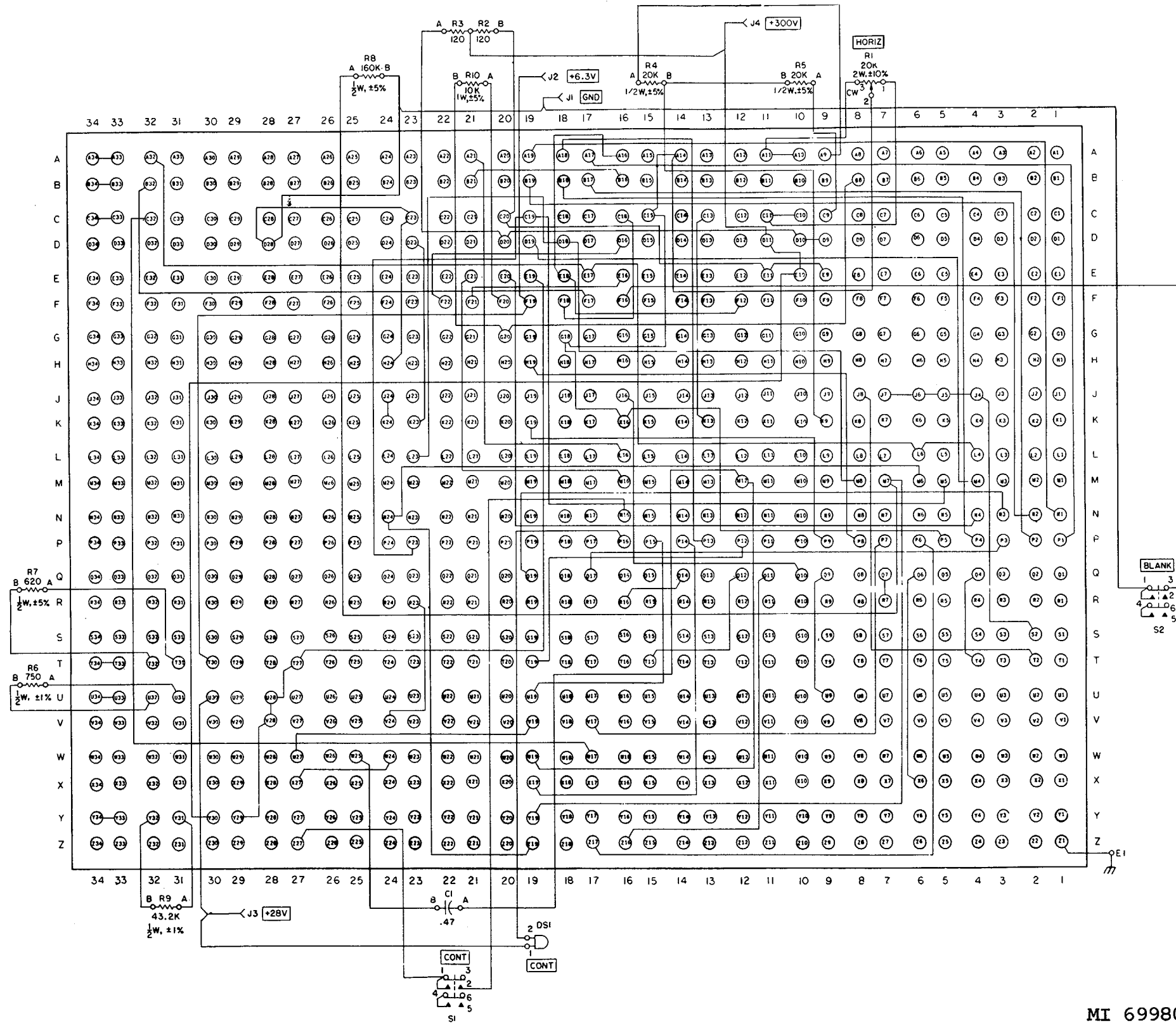
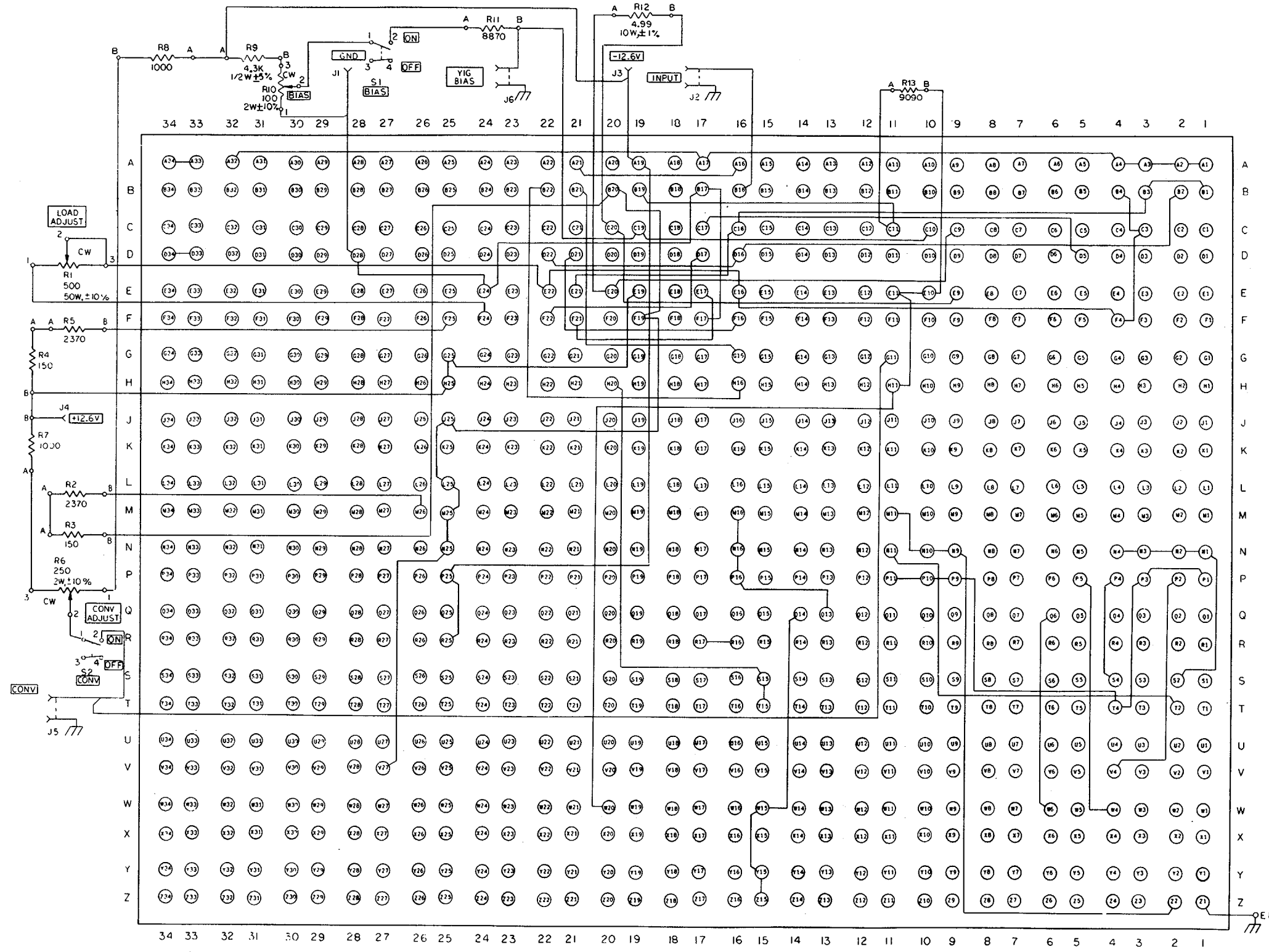

Figure 3-52. Pb CWR8-1014 10671169 (FG 1705) - schematic.

MI 69980



MS 309263

Figure 3-53. Pb CWR8-1015A 10291959 (FG 1105) - schematic.

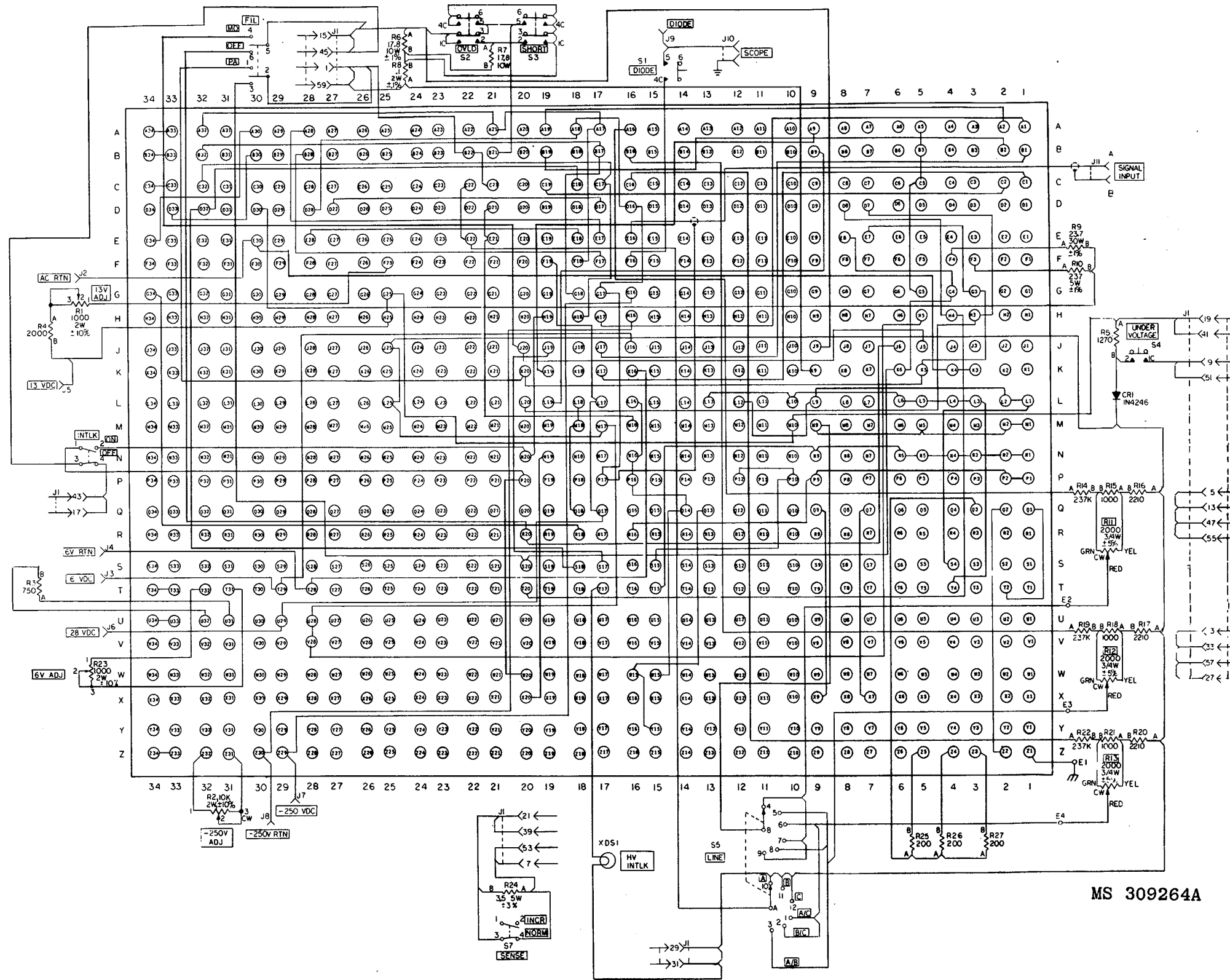
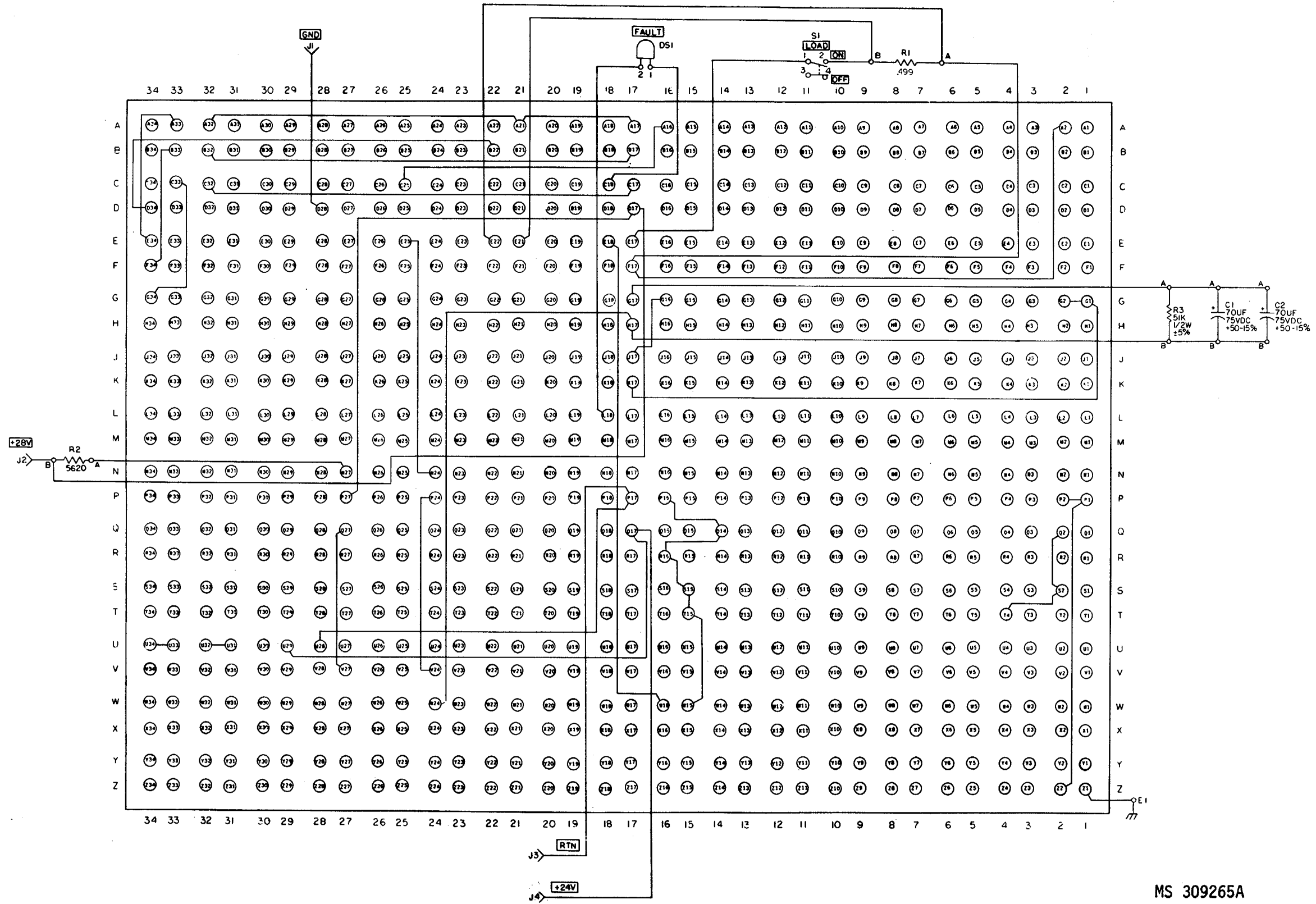

Figure 3-54. Pb CWR8-1017 11566013 (FG 4320) - schematic.



MS 309265A

Figure 3-55. Pb DP8-101B 11510199 (FG 1710) - schematic.

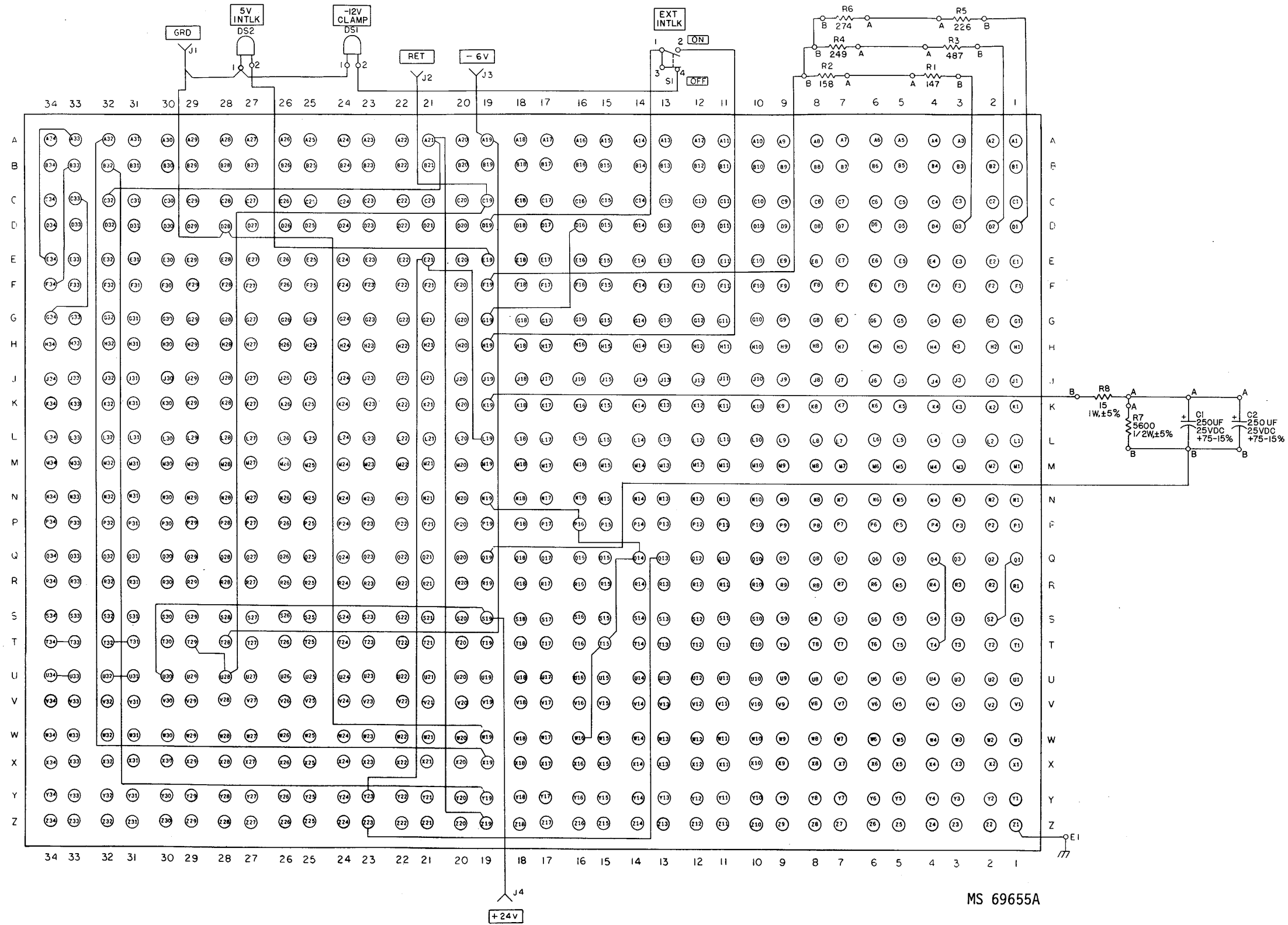
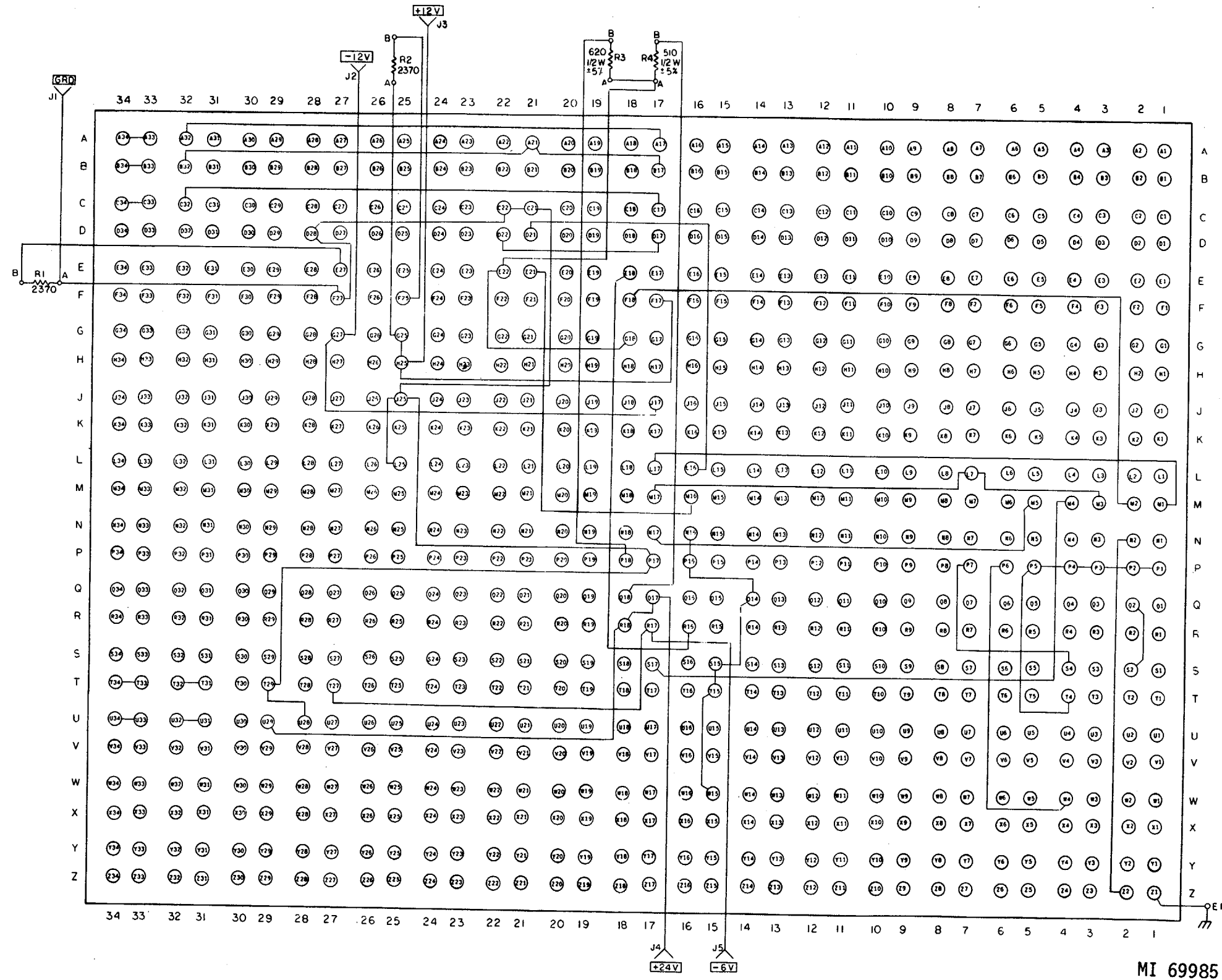
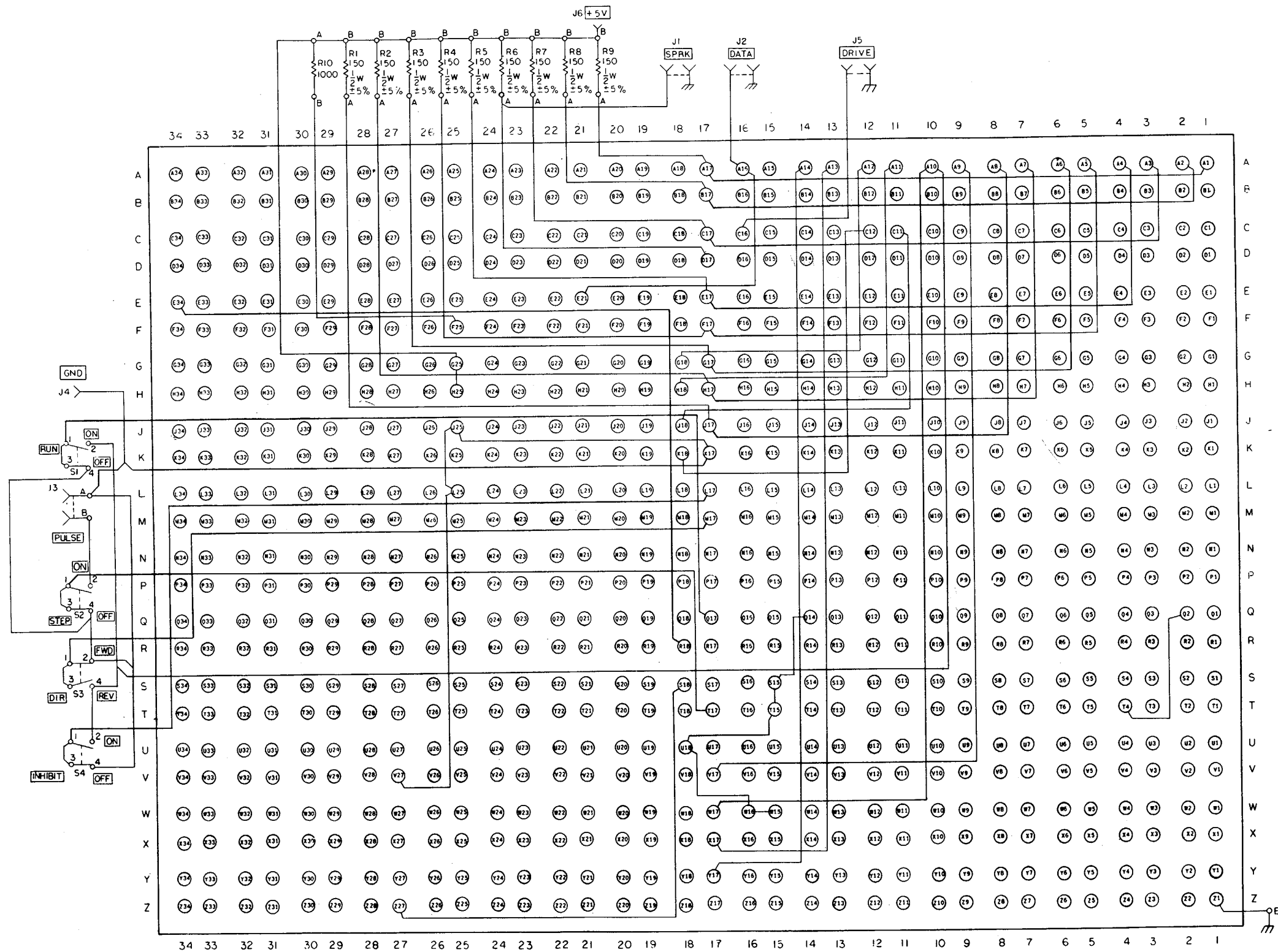

Figure 3-56. Pb DP8-102A 10288586 (FG 1715) - schematic.



MI 69985

Figure 3-57. Pb DP8-103 10671161 (FG 1720) - schematic.



NOTE: REFER TO APPENDIX B FOR SERIAL NUMBER EFFECTIVITY.

MI 69986A

Figure 3-58. Pb DP8-104 10671630* (W) (see note) (FG 1725) - schematic.

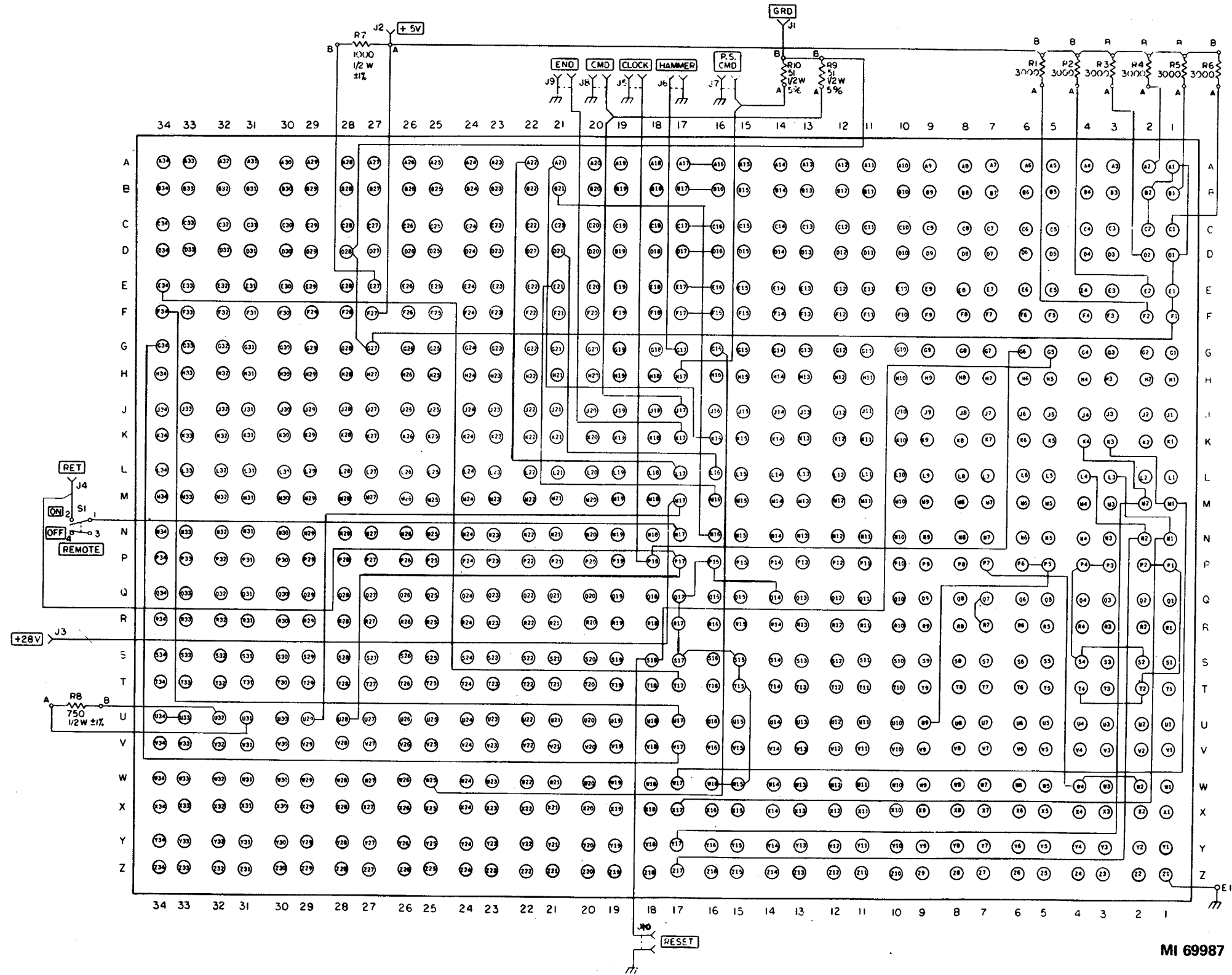
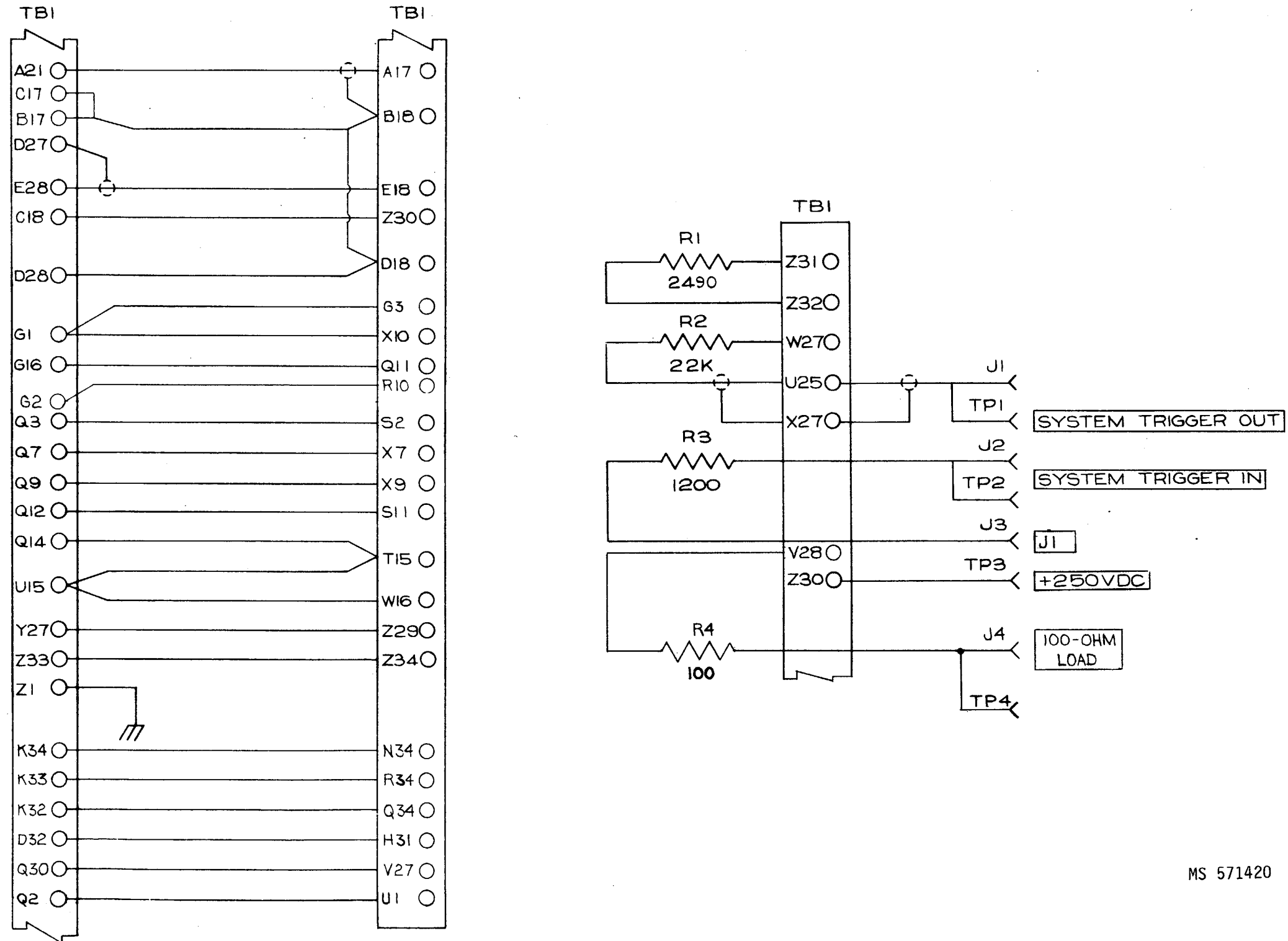

Figure 3-59. Pb DP8-105 10671761 (FG 1730) - schematic.



MS 571420

Figure 3-61. Pb HPAR-406 9195704 (FG 1145) - schematic.

3-111/(3-112 blank)

WIRING TABLE	
PIN NO.	
FROM	TO
B17	V30
B21	S21
C17	W27
F17	T28
N33	P34
Q1	S1
Q2	T2
Q3	S3
Q4	S4
Q13	U15
Q14	T15
T28	V27
T33	T34
U29	V29
U33	U34
V28	V29
V33	V34
Z1	GRD

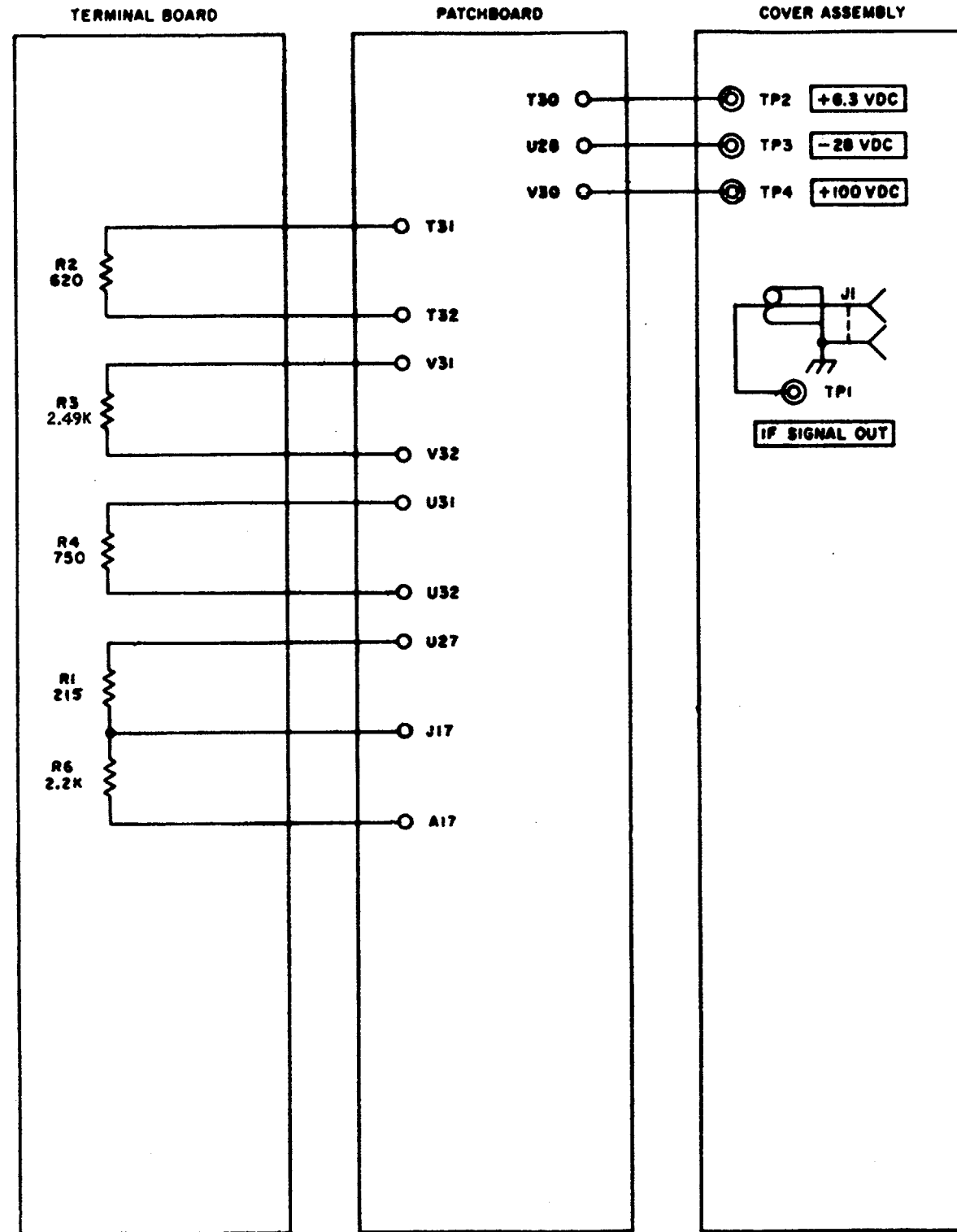

MI 69990A

Figure 3-62. Pb HPAR-408 9195705 (FG 1150) - schematic.

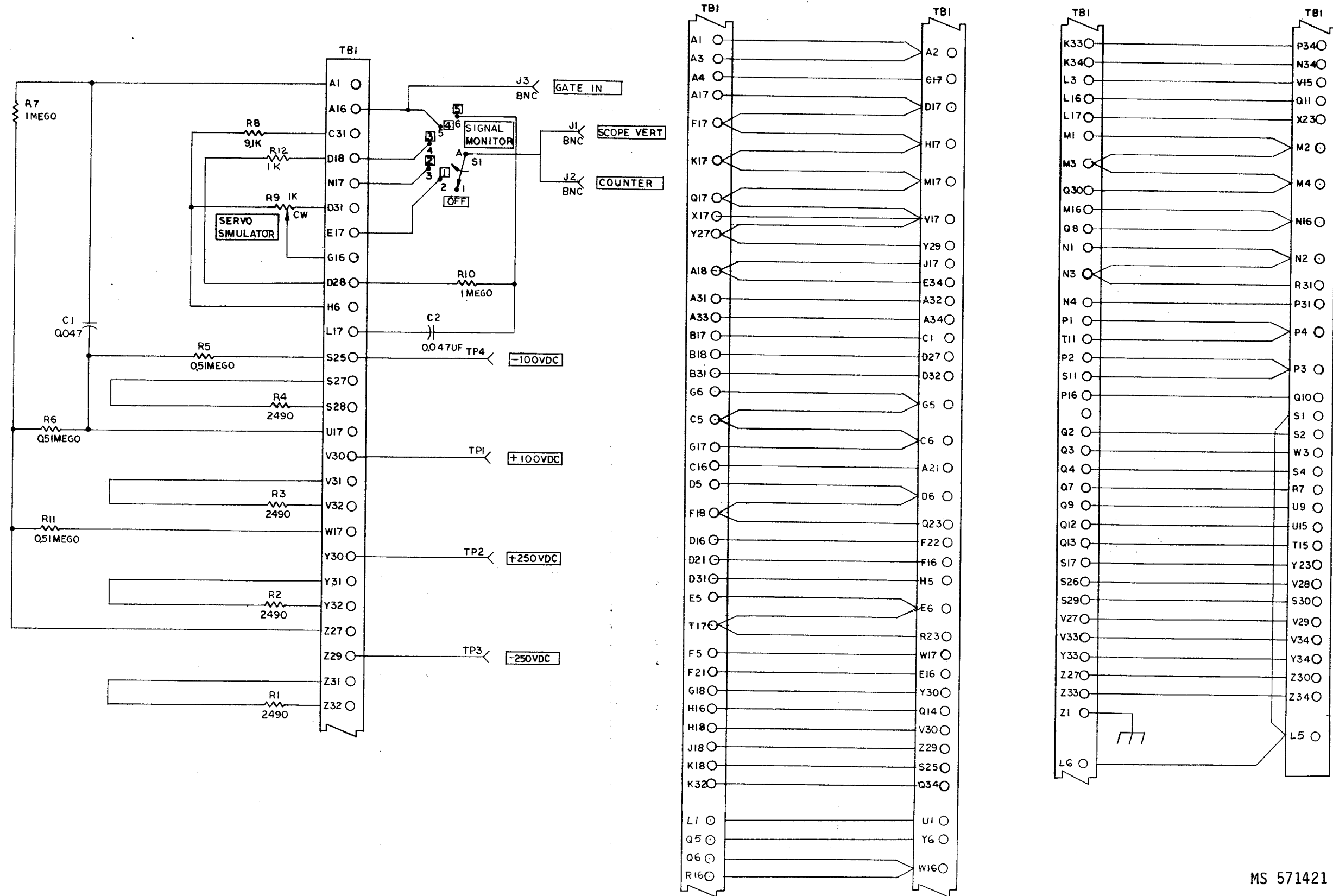

Figure 3-63. Pb HPAR-409 9195706 (FG 1160) - schematic.

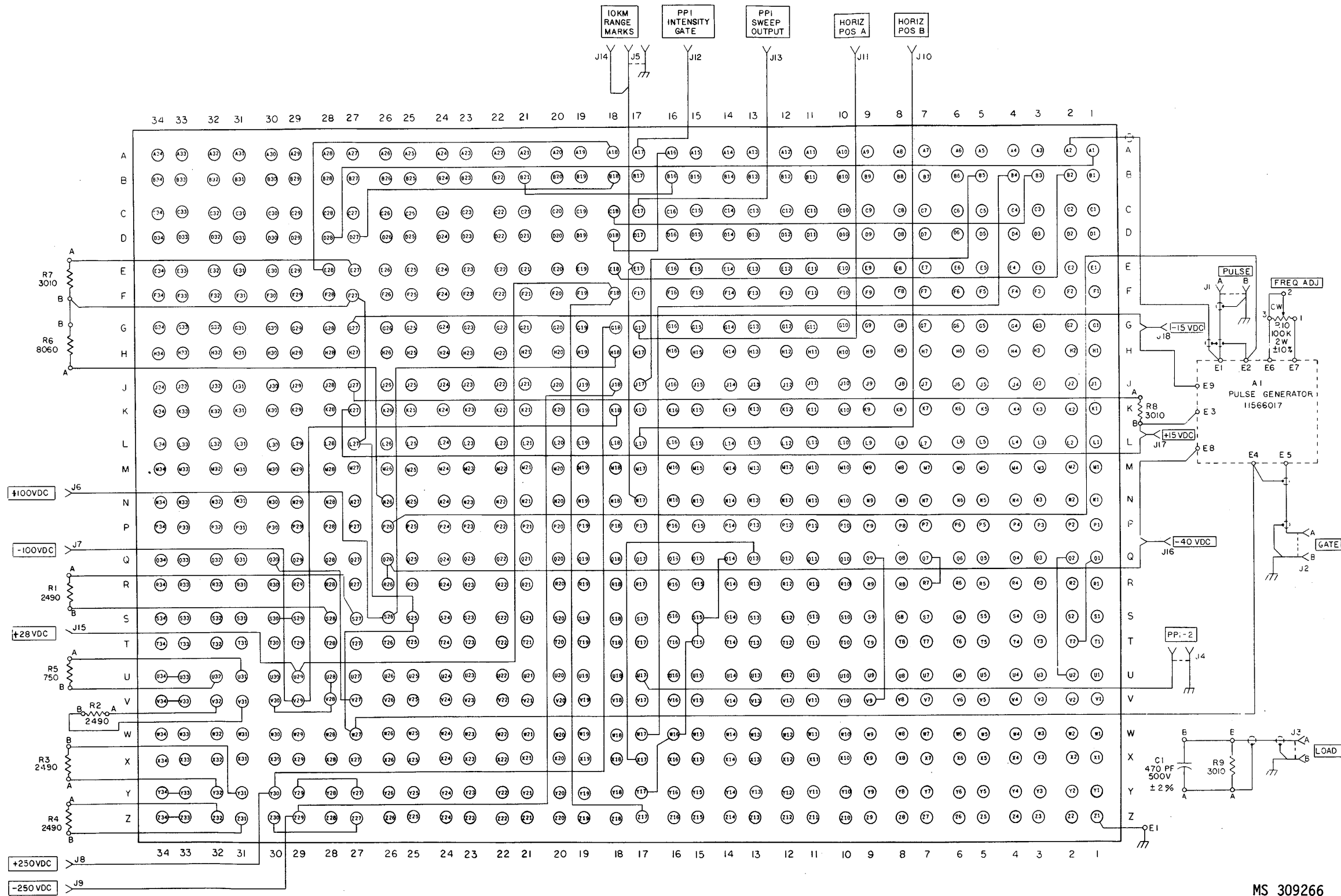
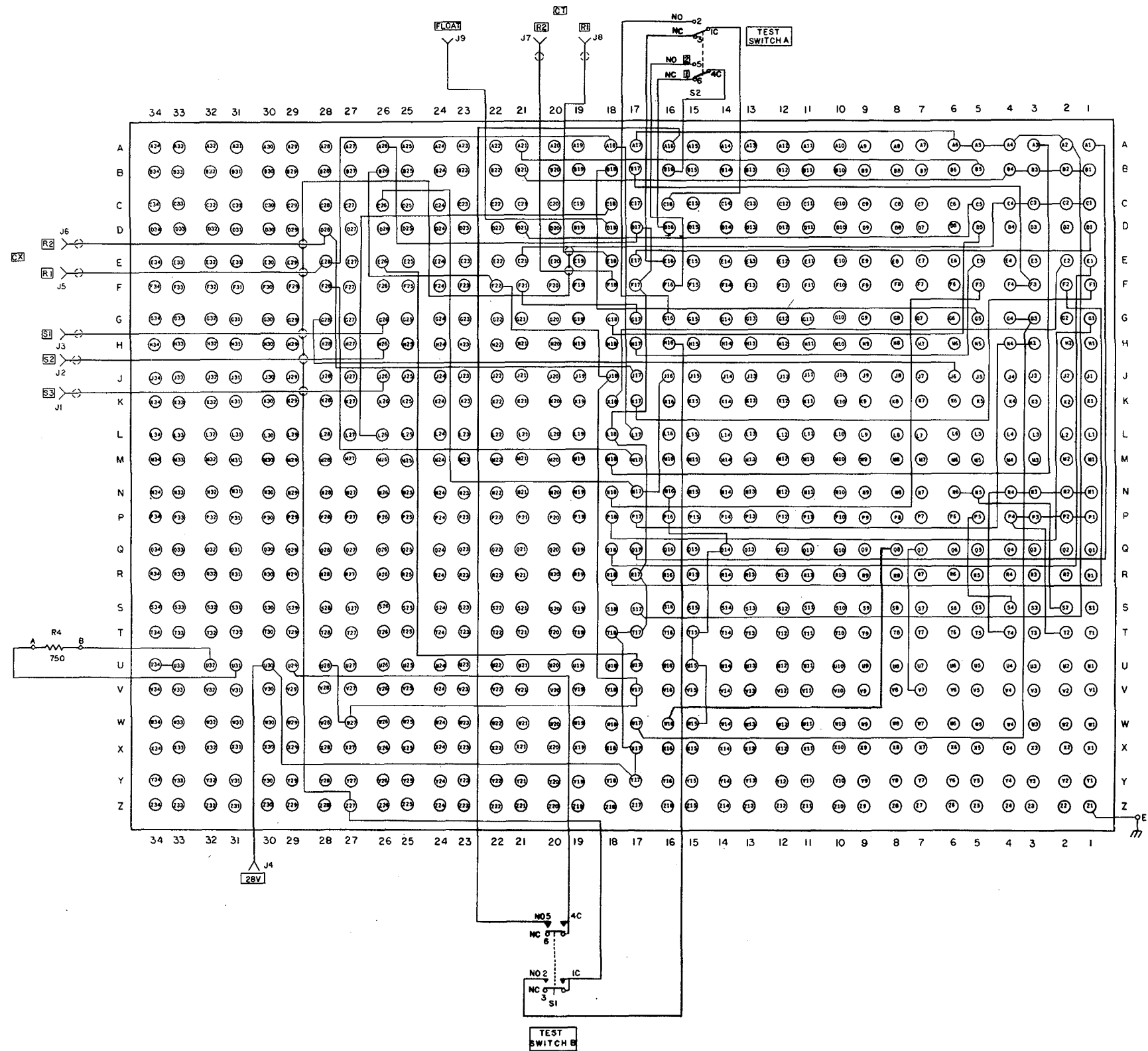
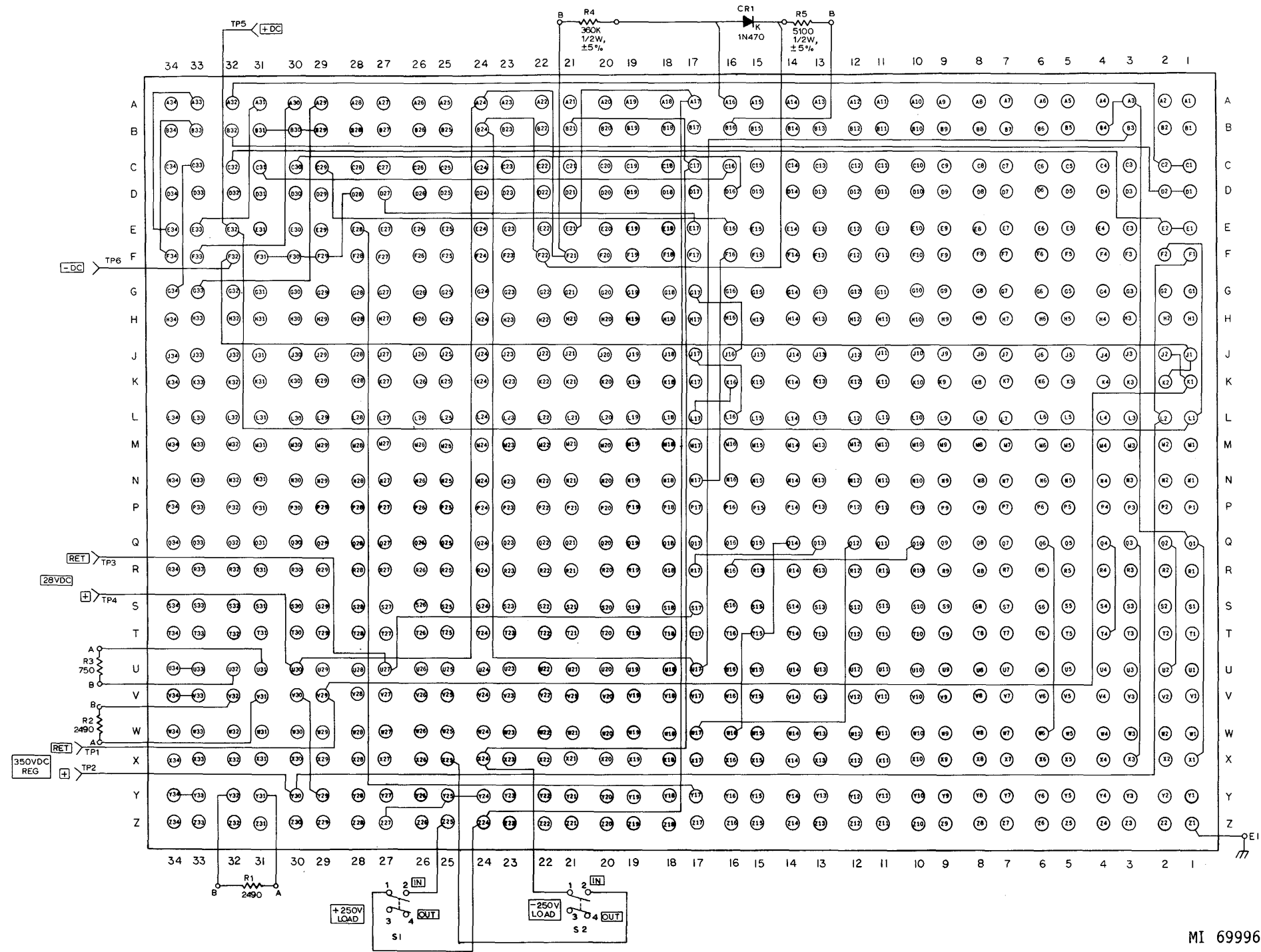

Figure 3-64. Pb HPAR-410A 11566016 (FG 1165) - schematic.



MS 309267

Figure 3-65. Pb HPAR-418B 11566015 (FG 1185) - schematic.



MI 69996A

Figure 3-66. Pb HPAR-438A 10675077 (FH 1190) - schematic.

Figure 3-67. Deleted.

3-117(3-118 blank)

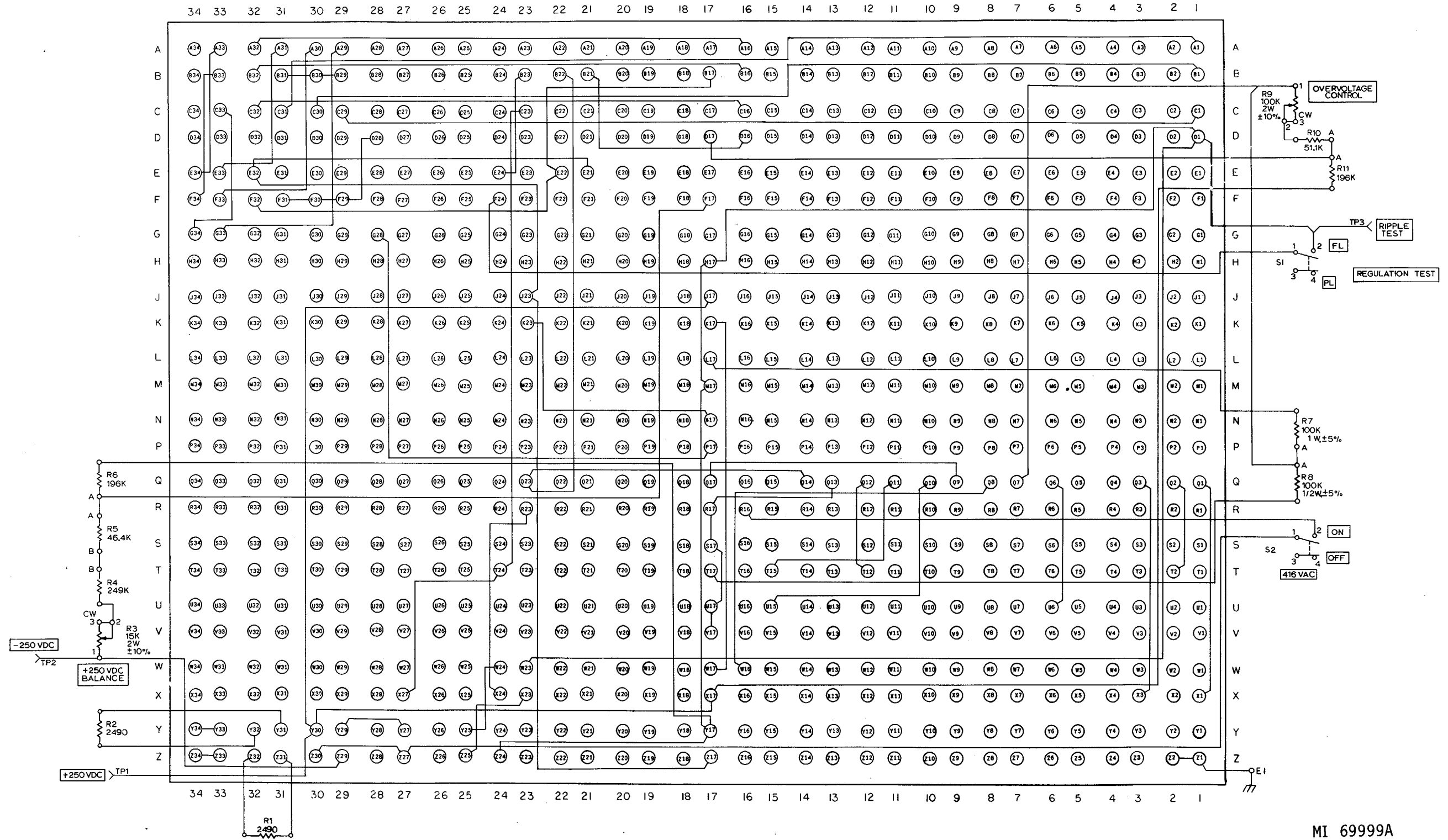

Figure 3-68. Pb HPAR-563A 10675078 (FH 1225) - schematic.

MI 69999A

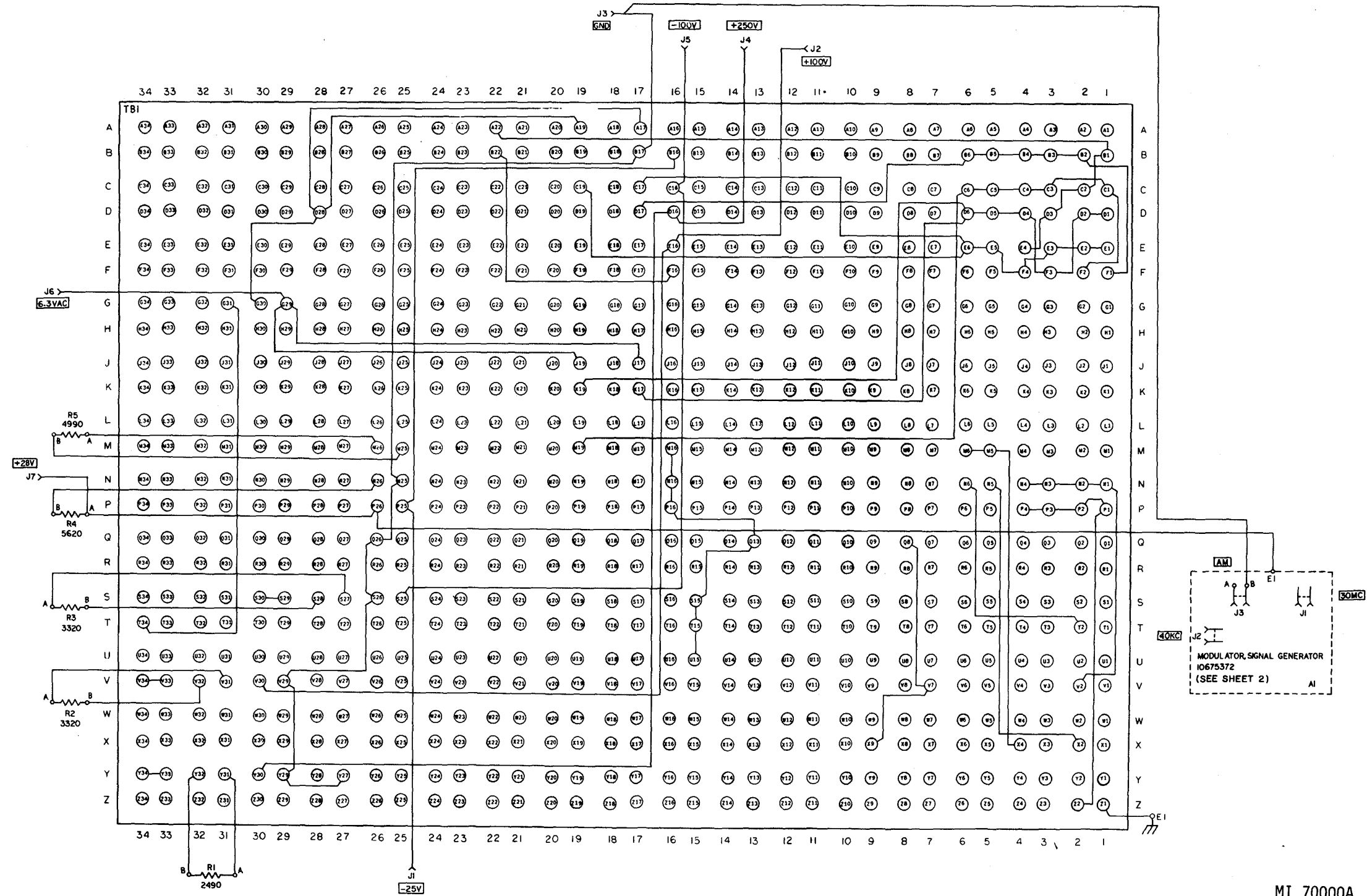
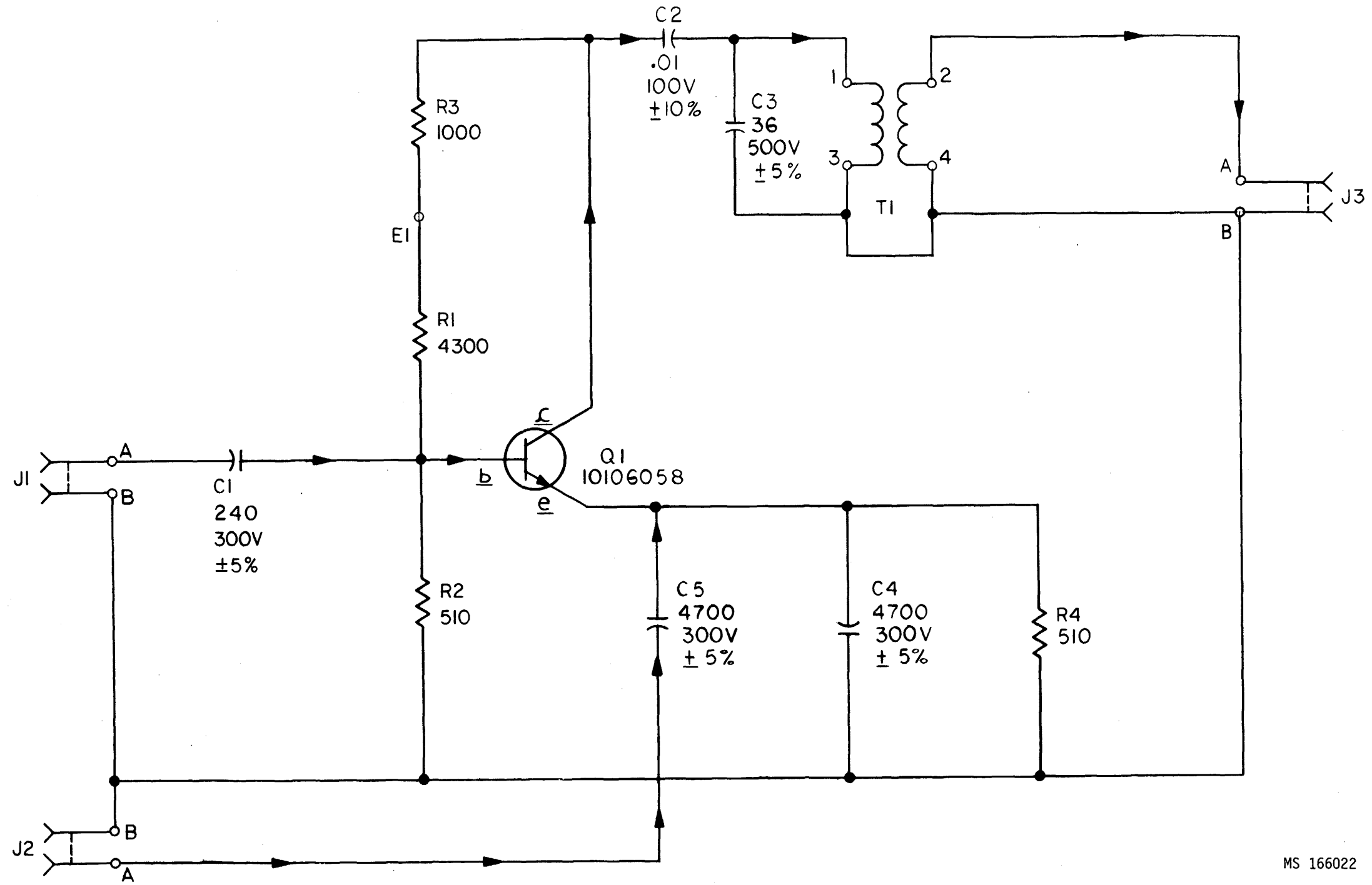

Figure 3-69. Pb HPAR-8-101A 10675326 (FH 1140) - schematic (sheet 1 of 2).

MI 70000A



MS 166022

Figure 3-69. Pb HPAR8-101 10675326 (FH 1140) - schematic (sheet 2 of 2).

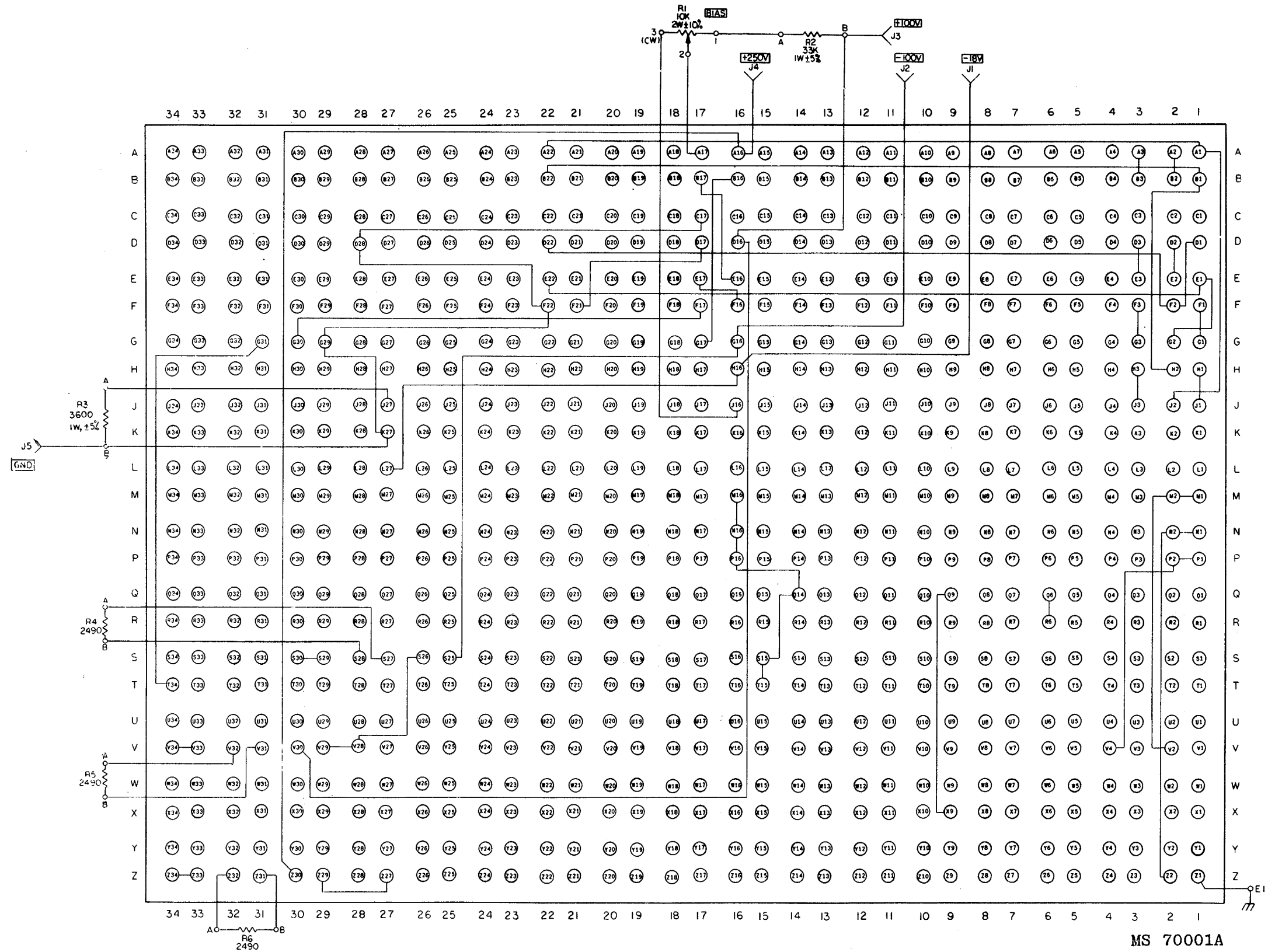

Figure 3-70. Pb HPAR 8-102 10674864 (FH 1170) - schematic.

C10

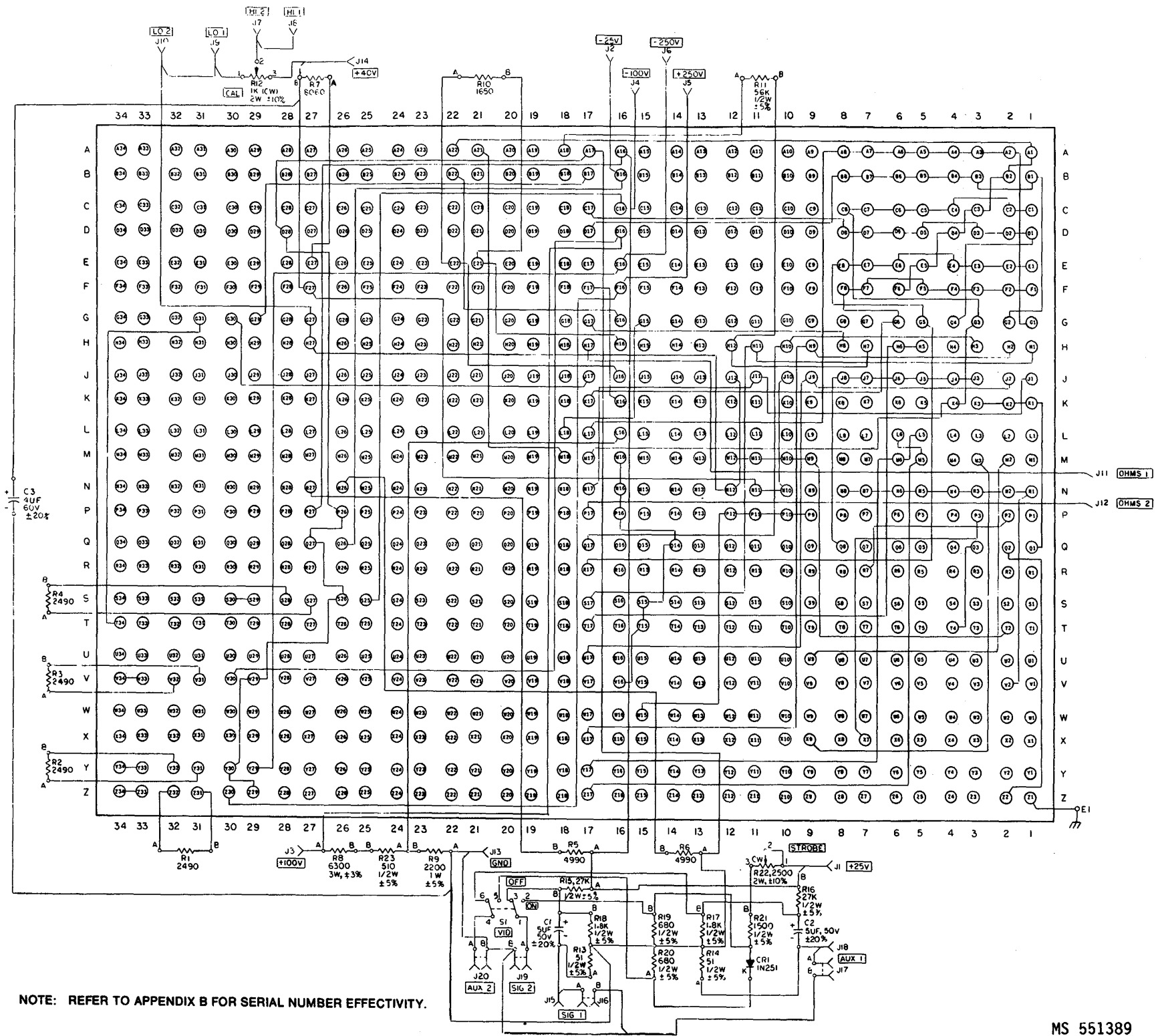
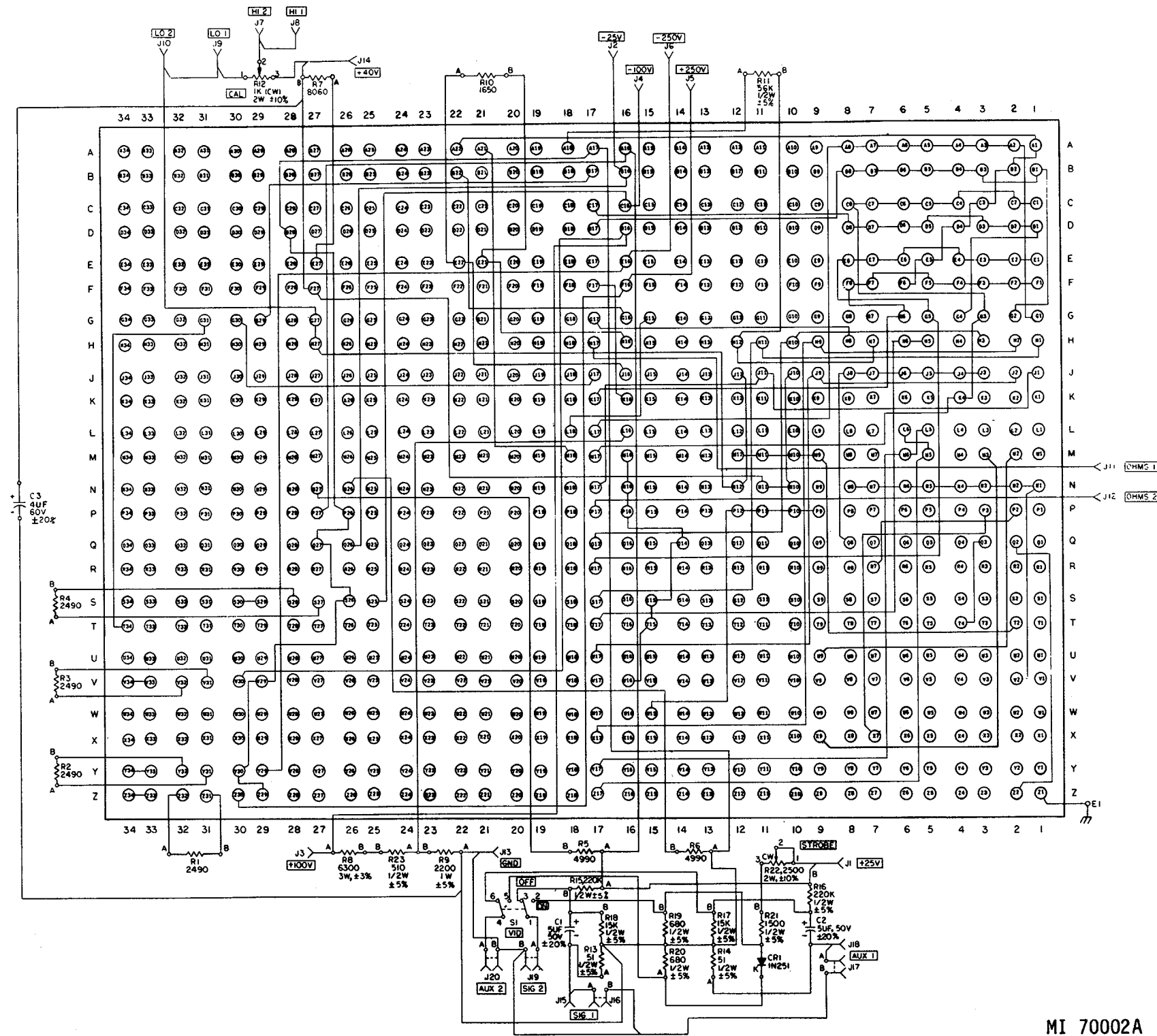

Figure 3-70.1. Pb HPAR 8-103A 13219772 *(AL) (see note) (FG 1195) - schematic.



MI 70002A

NOTE: REFER TO APPENDIX B FOR SERIAL NUMBER EFFECTIVITY.

Figure 3-71. Pb HPAR 8-103 10675241 *(AK) (see note) (FG 1195) - schematic.

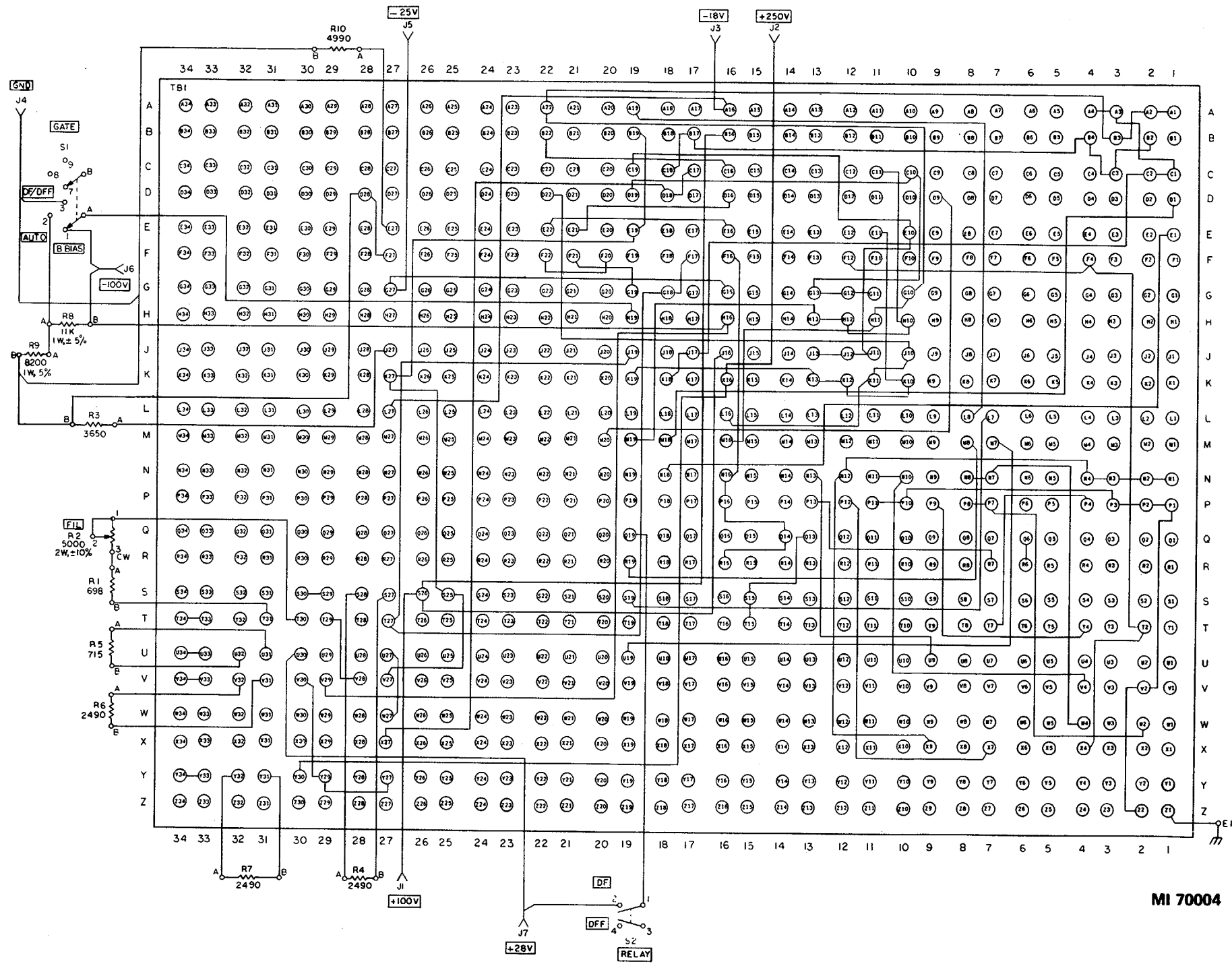
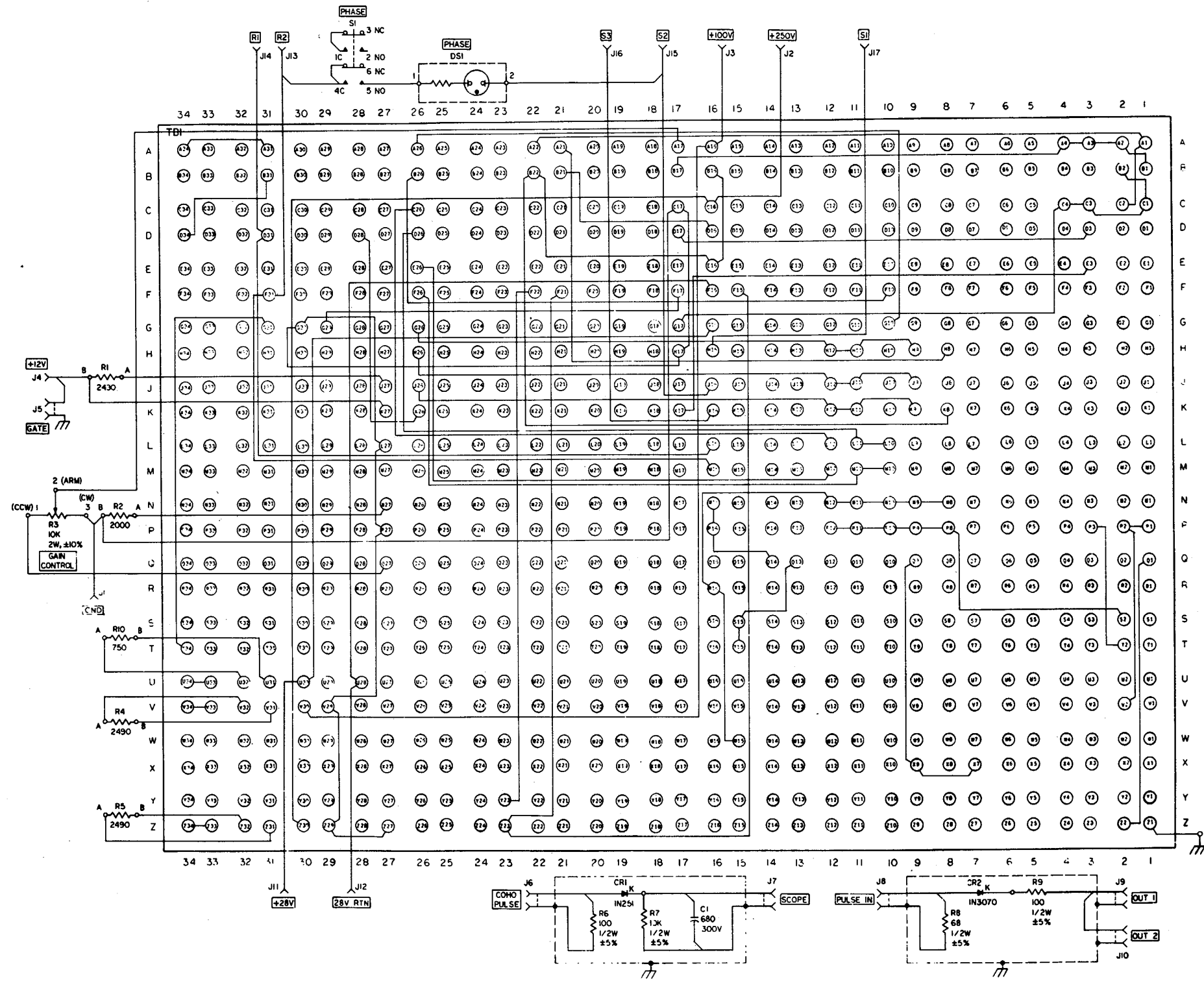

Figure 3-72. Pb HPAR 8-105 10675090 (FG 1215) - schematic.



MI 70007

Figure 3-73. Pb HPAR 8-108 10675328 (FG 1170) - schematic.

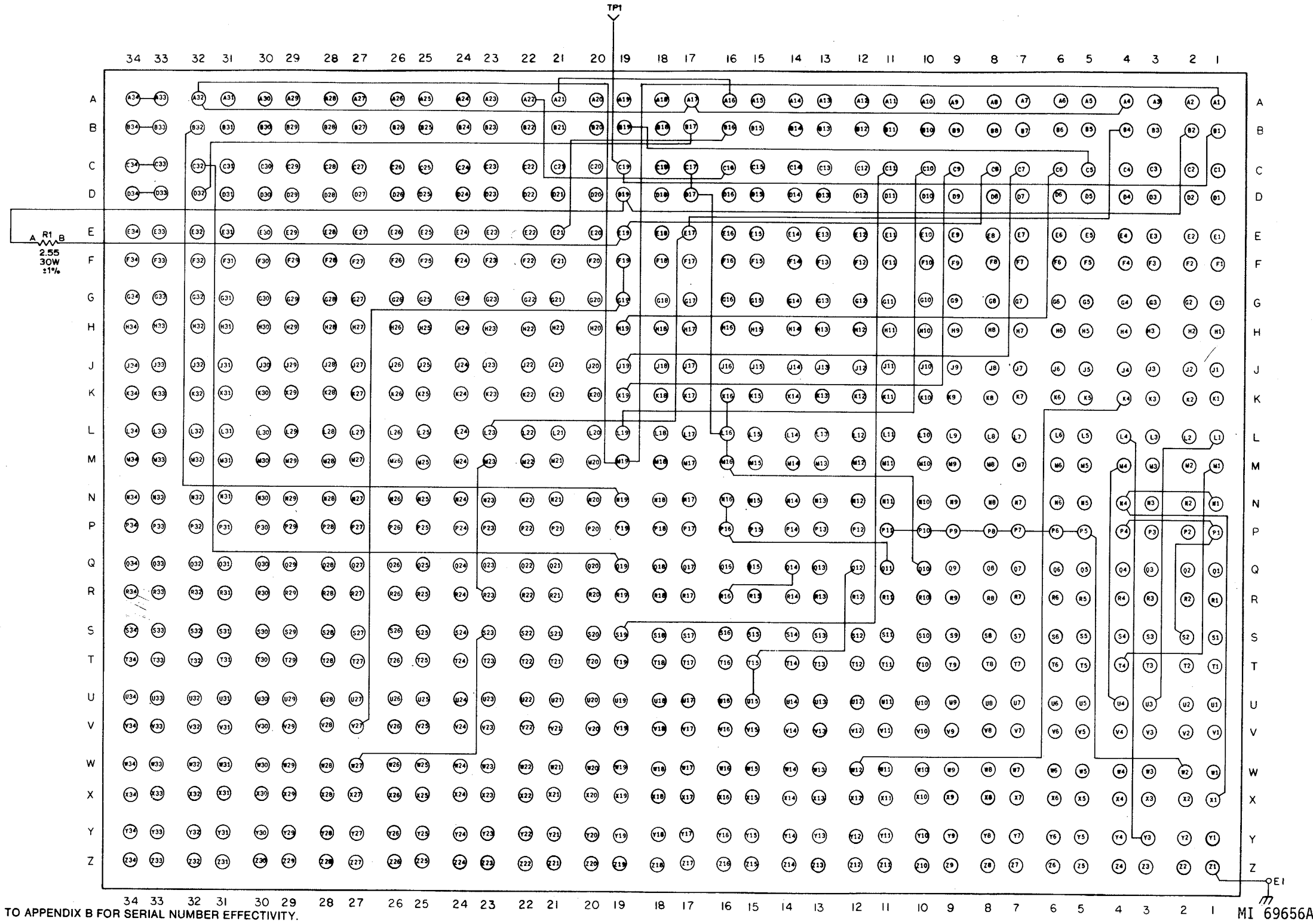

Figure 3-74. Pb HPI-501B 10288654 *(AB) (see note) (FG 1240) - schematic.

WIRING TABLE	
FROM	TO
A1	M19
A2	C19
A3	A6
A3	D19
A8	M20
A9	A20
A10	T19
A11	L19
A12	L20
A13	A19
A16	D22
B3	C20
B4	G20
B5	E3
B16	E21
B21	E16
E3	P19
E4	K20
E5	K19
E19	T29
F1	Y6
F2	V6
F4	U9
F16	Q6
F19	T28
G1	G2
G2	G3
G3	G4
G4	G3
G5	G6
G16	K19
G19	Z29
G20	G23
H1	H7
H1	X9
H4	U7
H5	S1
H16	J16

WIRING TABLE	
FROM	TO
H19	Y30
H20	H23
H23	V27
J1	J7
J1	X7
J4	U10
J5	W3
J16	Q7
J19	V29
K1	K6
K1	W4
K2	K4
K2	T4
K3	T3
K6	K8
K8	K9
K9	K10
K10	K11
K11	K12
K12	K13
K16	Q8
K21	U25
L1	L6
L1	S3
L2	L4
L2	X3
L3	L5
L3	U4
L6	L8
L8	L9
L9	L10
L10	L11
L11	L12
L12	L13
L16	Q9
M1	Y12
M3	P2
M4	V1

WIRING TABLE	
FROM	TO
M16	N19
N1	N3
N1	U2
N2	N5
N2	T2
N3	N4
N6	W19
N16	Q11
N19	Q10
P1	T1
P2	X1
P4	X11
P16	Q12
P32	Q34
P33	P34
Q7	Y7
Q13	U15
Q14	T15
T33	T34
U30	W27
U31	U32
U33	U34
V28	V30
V33	V34
Y27	Y29
Y29	Z30
Y33	Y34
Z33	Z34
Z1	GRD

NOTE: REFER TO APPENDIX B FOR SERIAL NUMBER EFFECTIVITY.

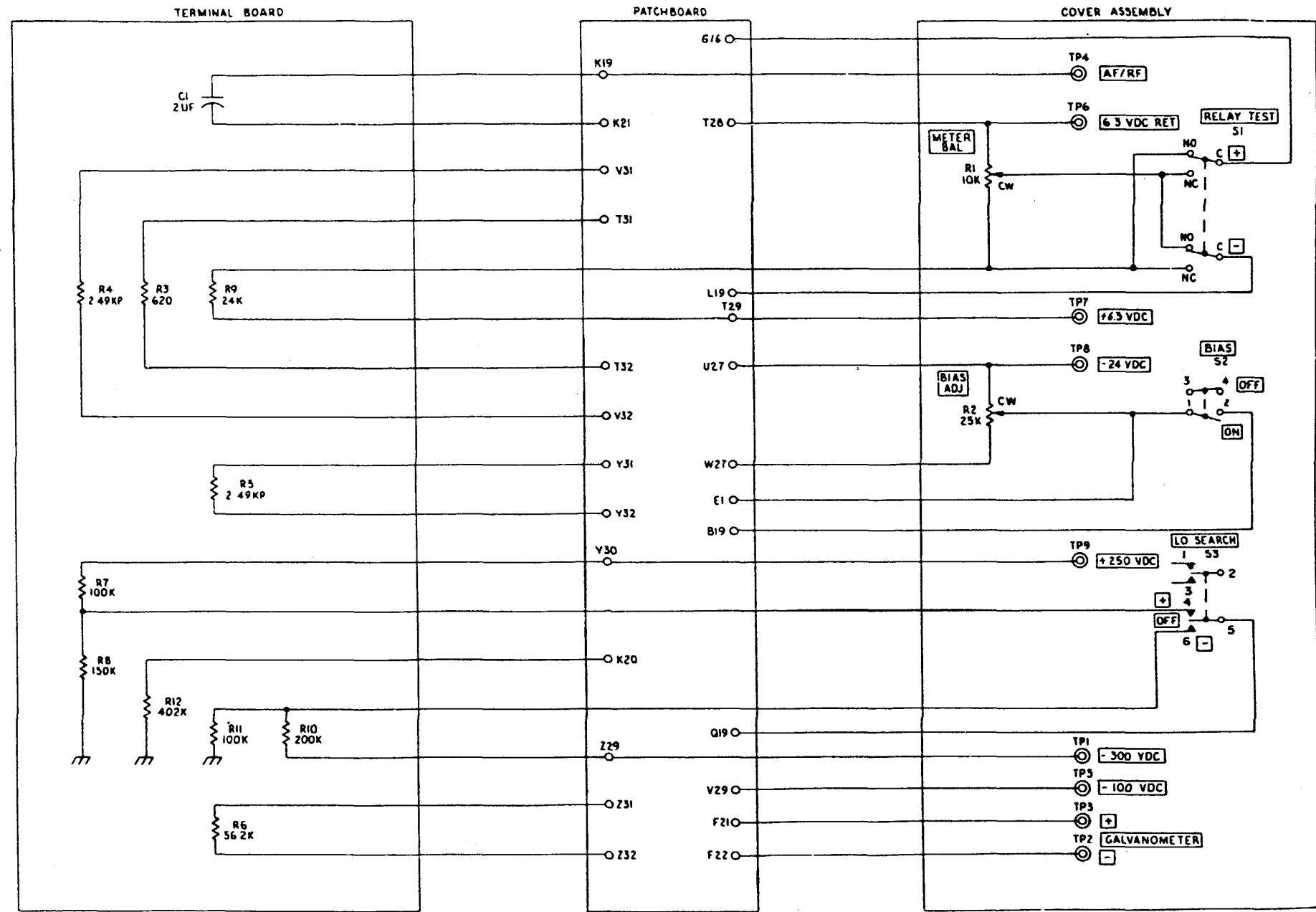

MI 70009B

Figure -3-75. Pb HPI-502B 10173971 *(AB) (see note) (FG 1245)- schematic .

WIRING TABLE	
PIN NO.	
FROM	TO
A17	A21
A17	Q17
A21	C32
A32	M17
A33	A34
B32	N17
B33	B34
C17	Q7
C33	C34
D33	D34
F21	G23
G17	H16
H1	W6
H16	Q11
J1	R10
J16	K16
K1	V12
K16	Q10
L1	T4
L16	M16
M1	X3
M16	Q12
N1	S2
N16	P16
P1	X1
P16	Q13
Q8	T15
Q14	R16
T15	U15
Y33	Y34
Z1	GRD

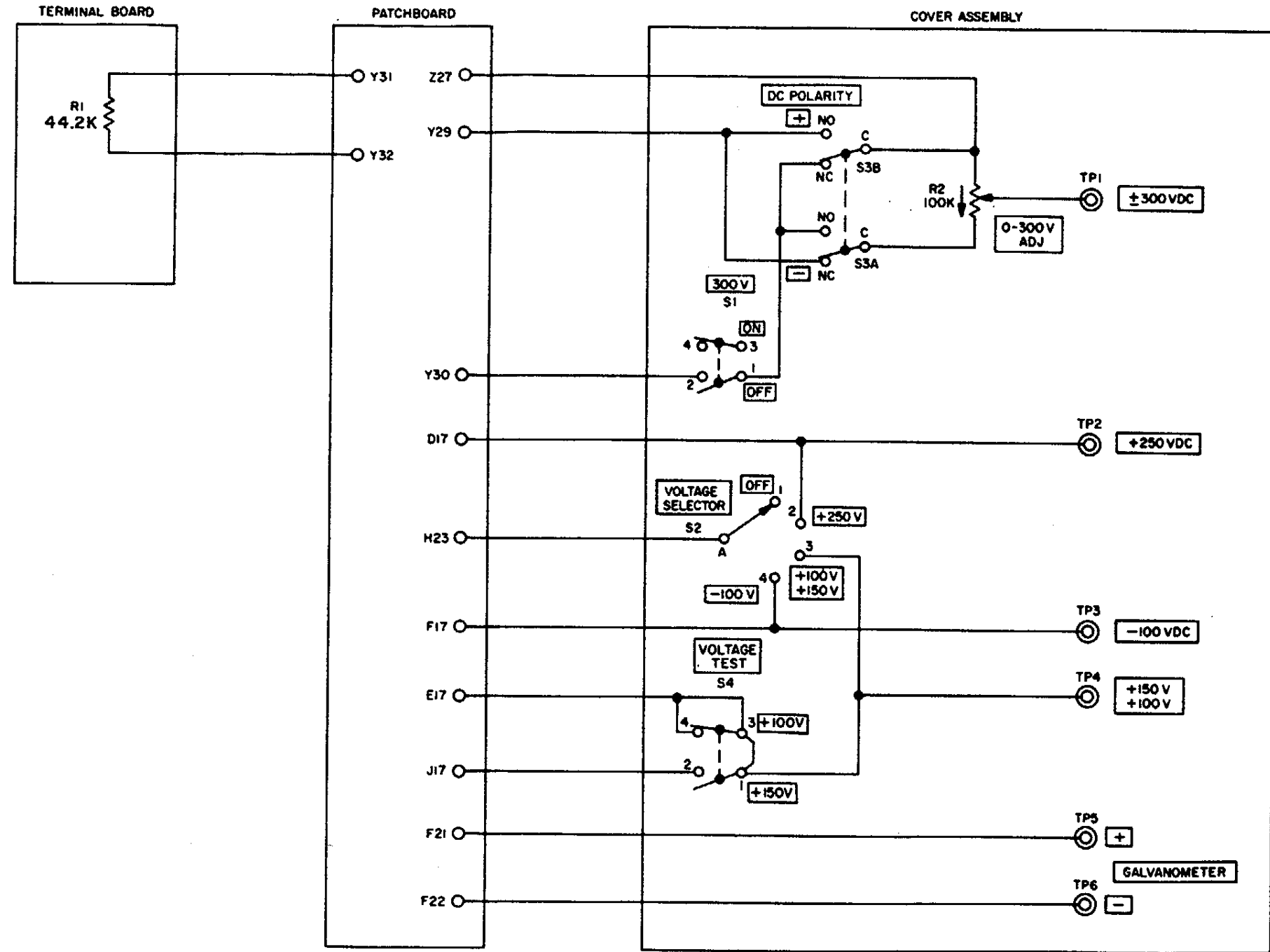

MI 70010A

Figure -3-76. Pb HPI-504A 10108023 (FG 1250)- schematic .

WIRING TABLE	
PIN NO.	
FROM	TO
A1	A2
A2	A21
A16	K21
B2	Y17
B16	E21
C17	Q12
D17	Y30
E17	T29
F2	T4
F16	G16
F17	T28
G2	X3
G16	Q4
H1	H2
H2	W10
H16	Q11
H17	X30
J1	X13
J2	X12
J16	Q10
K17	V29
K21	Q21
L16	Q6
M16	Q5
N1	N2
N1	S2
N16	Q8
P1	P2
P1	T1
P16	Q9
P32	Q34
P33	P34
Q2	X7
Q3	V17
Q7	X9
Q14	T15
Q21	U25
T15	U15
T27	V28
T33	T34
V30	W27
V33	V34
X27	X29
X33	X34
Y27	Y29
Y33	Y34
Z1	GRD

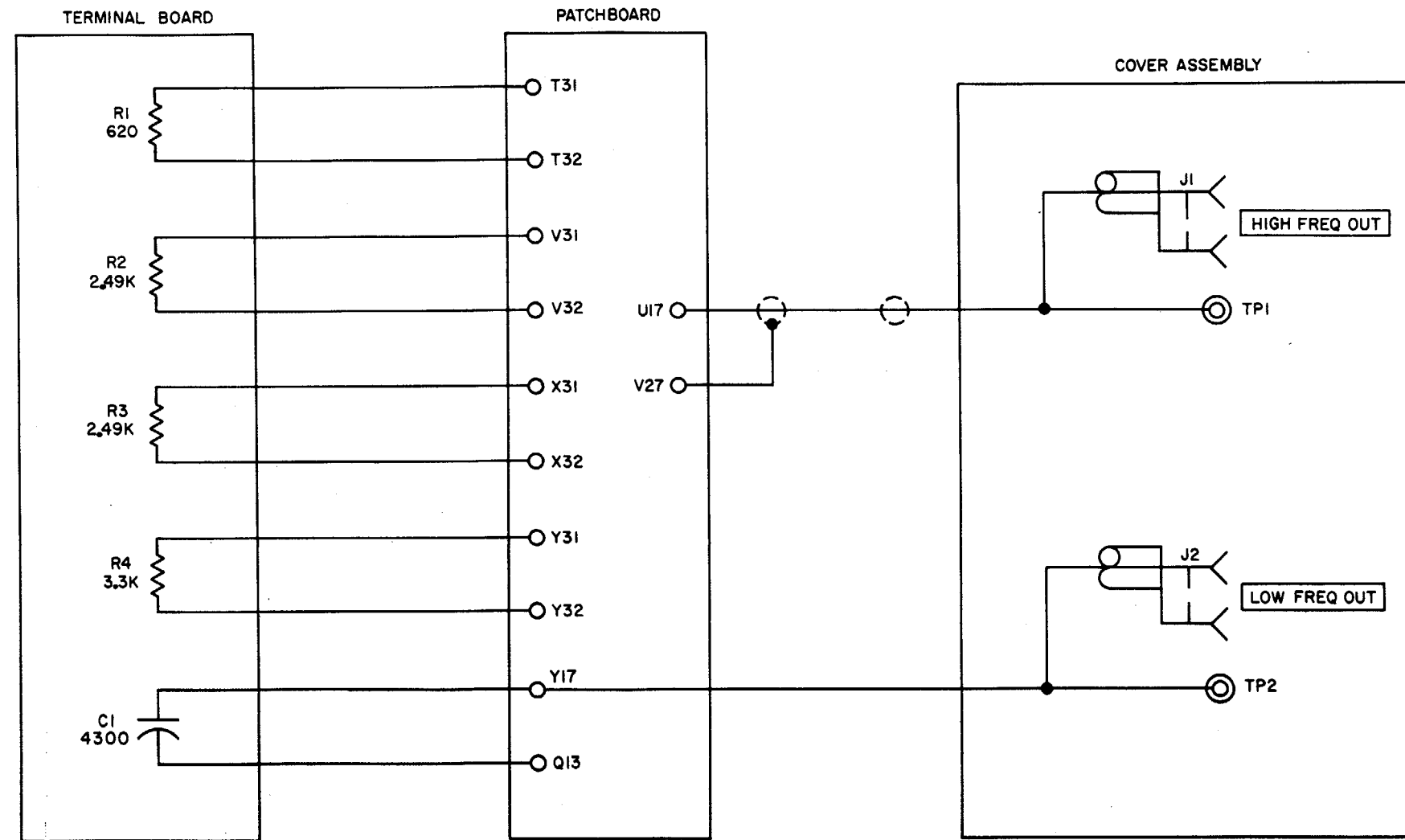

NOTE: REFER TO APPENDIX B FOR SERIAL NUMBER EFFECTIVITY.

MI 70011A

Figure -3-77. Pb HPI-508A 1018345 *(AB) (see note) (FG 1260)- schematic .

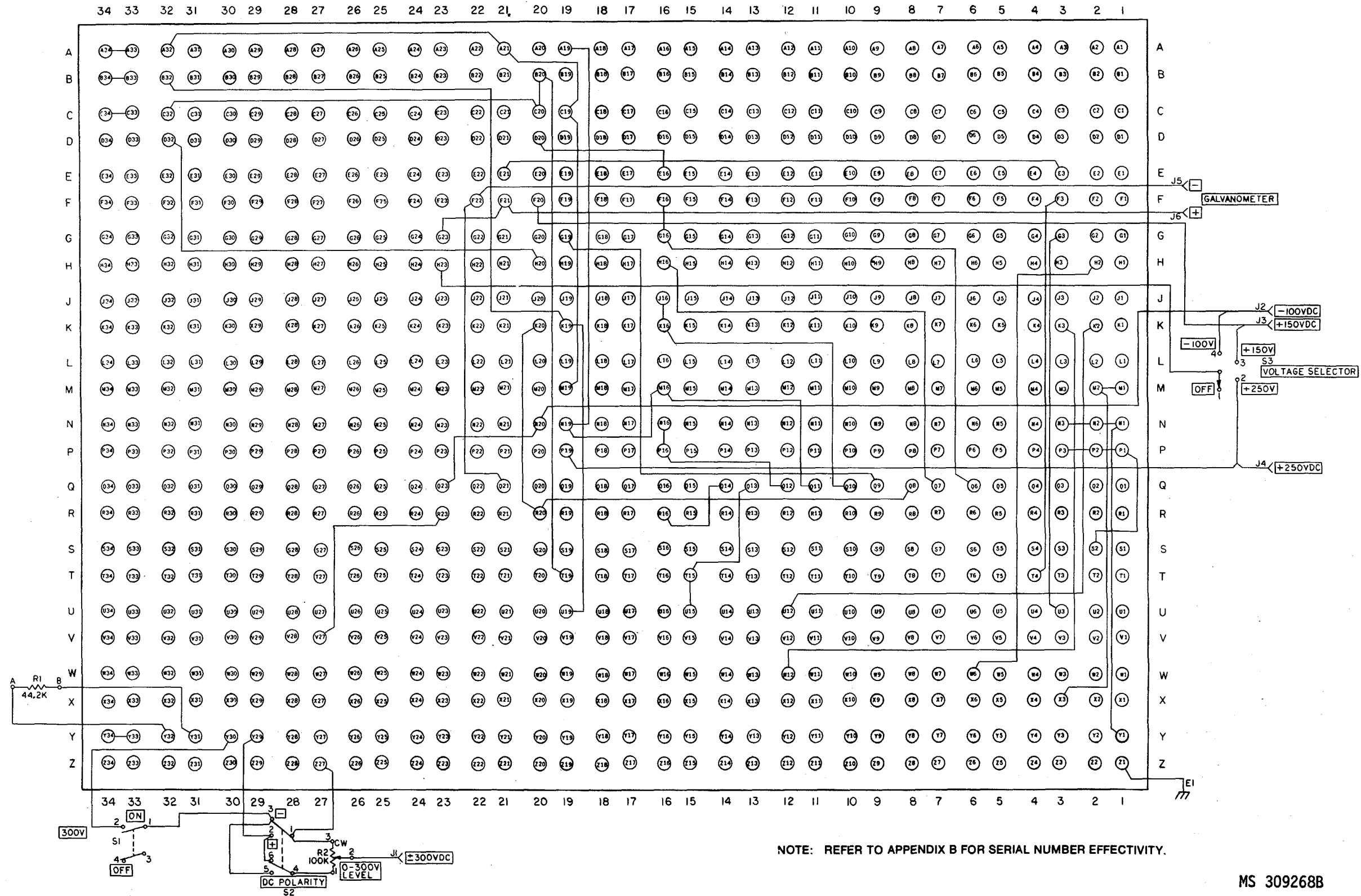

Figure -3-78. Pb HPI-509B 11566537 *(AB) (see note) (FG 1265)- schematic .

MS 309268B

WIRING TABLE	
PIN NO.	
FROM	TO
A1	A2
A1	M17
A3	A4
A3	N17
A17	B1
A22	F16
B1	C2
B3	C4
B3	X17
B16	B21
B18	F5
C16	F22
C17	Q13
C18	F6
D1	E2
D1	U17
D3	E4
D3	Z17
D16	E21
D17	Y30
E16	F21
F7	V17
H17	W30
K17	V29
L1	L3
L1	W3
L16	L17
L16	M16
M1	M3
M1	W3

WIRING TABLE	
PIN NO.	
FROM	TO
M3	M5
M5	M6
M7	S1
M16	Q12
N1	N3
N3	T4
N16	P16
P1	P3
P1	T2
P2	P4
P4	Y6
P5	P6
P5	W2
P6	P7
P16	Q14
P32	Q34
P33	P34
Q7	X7
Q8	X9
Q10	T15
Q21	U25
T15	U15
V28	V30
V33	V34
W27	W29
W33	W34
Y27	Y29
Y33	Y34
Z1	GRD

NOTE: REFER TO APPENDIX B FOR SERIAL NUMBER EFFECTIVITY.

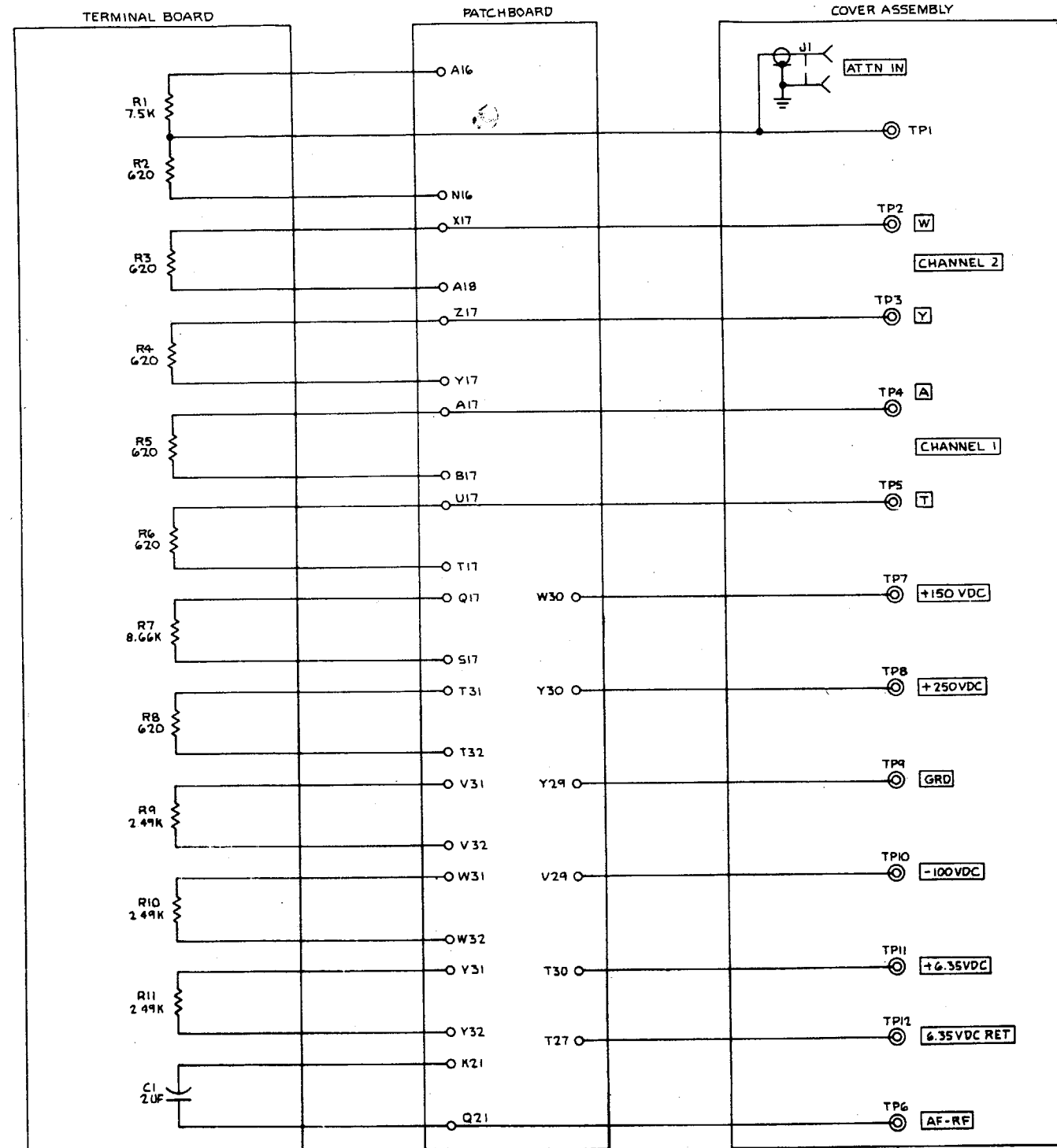

MI 70013A

Figure -3-79. Pb HPI-510B 10173976 *(AB) (see note) (FG 1270)- schematic .

WIRING TABLE	
PIN NO.	
FROM	TO
D17	Y30
E17	T30
F17	T27
K21	Q21
K21	U25
L17	Q13
P32	Q34
P33	P34
Q7	X7
Q9	X9
Q14	T15
T15	U15
T33	T34
Y29	Z27
Y33	Y34
Z1	GRD



SHIELDED TO U27

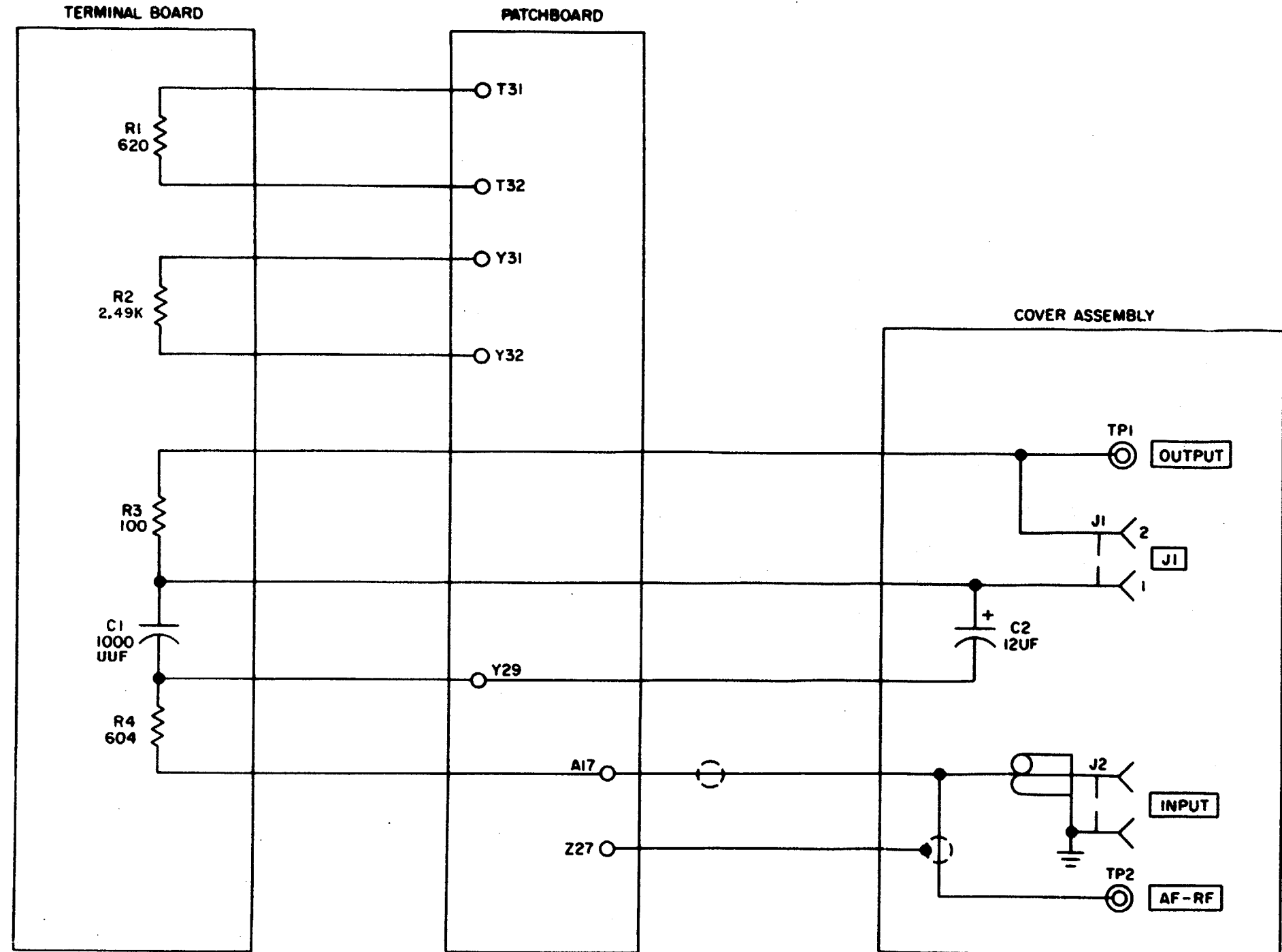

MI 70014B

NOTE: REFER TO APPENDIX B FOR SERIAL NUMBER EFFECTIVITY.

Figure 3-80. Pb HPI-514 10106893 *(AB) (see note) (FG 1275)- schematic .

WIRING TABLE	
FROM	TO
A16	B21
A21	C16
A32	D17
A33	A34
B18	U17
C1	D17
D32	J17
D33	D34
E1	H17
E3	E4
E5	E17
E16	E21
H2	U3
H4	U7
H16	J16
H18	U27
J2	J5
J4	W11
J5	M1
J16	K16
J30	L30
K3	K4
K3	S3
K16	Q12
K16	L17
K18	L17
K32	Q34
K33	R34
K34	N34
L1	L5
L1	V3
L3	M4

↓

↓ SHIELDED TO D32

WIRING TABLE	
FROM	TO
L3	U4
L4	S1
L16	M16
L30	V28
M1	T4
M16	Q13
N1	N2
N1	X1
N3	W1
N4	P3
N16	P16
N18	T29
P1	S2
P2	P3
P2	T2
P4	U9
P16	Q14
P16	X17
P18	T27
Q10	W10
Q14	R16
Q17	V24
R16	T15
S17	W24
T15	U15
T33	T34
U17	U29
U33	U34
V25	W25
V27	V30
V33	V34
Z1	GRD

NOTE: REFER TO APPENDIX B FOR SERIAL NUMBER EFFECTIVITY.

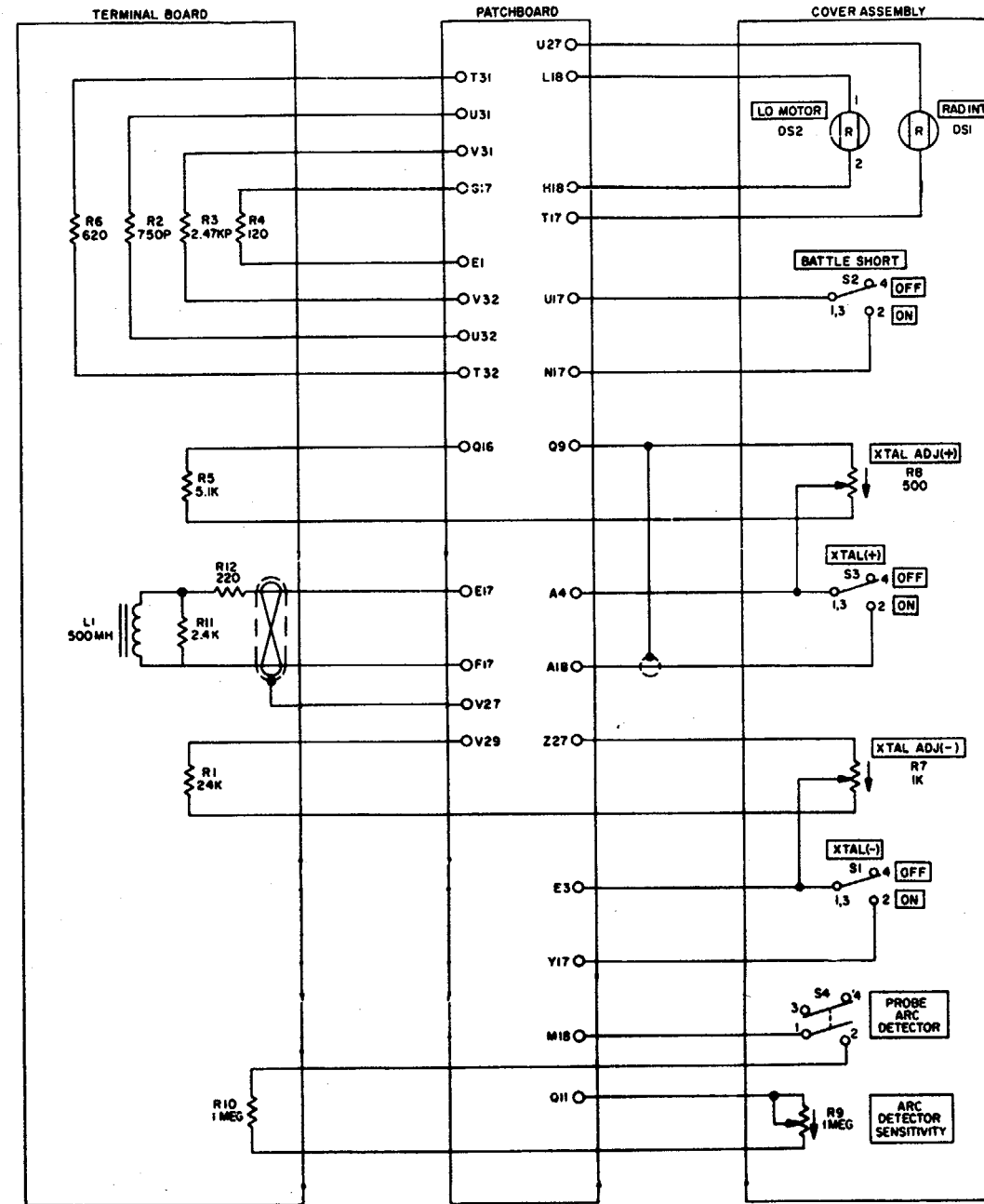

MI 70015A

Figure 3-81. Pb HPI-516C 10110372 *(AB) (see note) (FG 1280)- schematic .

WIRING TABLE		WIRING TABLE	
FROM	TO	FROM	TO
A2	A3	M16	Q12
A2	M2	N1	N2
A3	A4	N2	N3
A16	E21	N3	N4
A16	C6	N4	N5
B1	B3	N5	T2
B3	L17	N6	U3
B4	X29	N6	V3
B5	F5	N16	P16
B16	B21	P1	P2
C16	D22	P2	X1
C17	Q13	P2	P3
D17	Y30	P3	P5
E17	T30	P4	U1
F8	X17	P6	V4
F17	T27	P16	Q4
G8	Y17	P34	P33
H2	H3	Q10	T18
H3	Z17	Q21	K21
H3	H4	Q34	P32
H17	W30	S26	V27
J16	K16	S29	S30
K1	K3	T15	U15
K2	S3	T33	T34
K3	K4	U25	Q21
K3	K5	U27	W17
K5	T3	U29	V17
K16	Q11	U33	U34
K17	S25	V28	V30
L1	L2	V31	V32
L2	L3	V33	V34
L3	L4	W27	W29
L4	U4	W33	W34
L5	T4	X7	Q7
L16	M16	X9	Q9
M1	M5	X31	X32
M3	X6	X33	X34
M4	Y6	Y27	Y29
M5	W6	Y33	Y34
		Z1	GRD

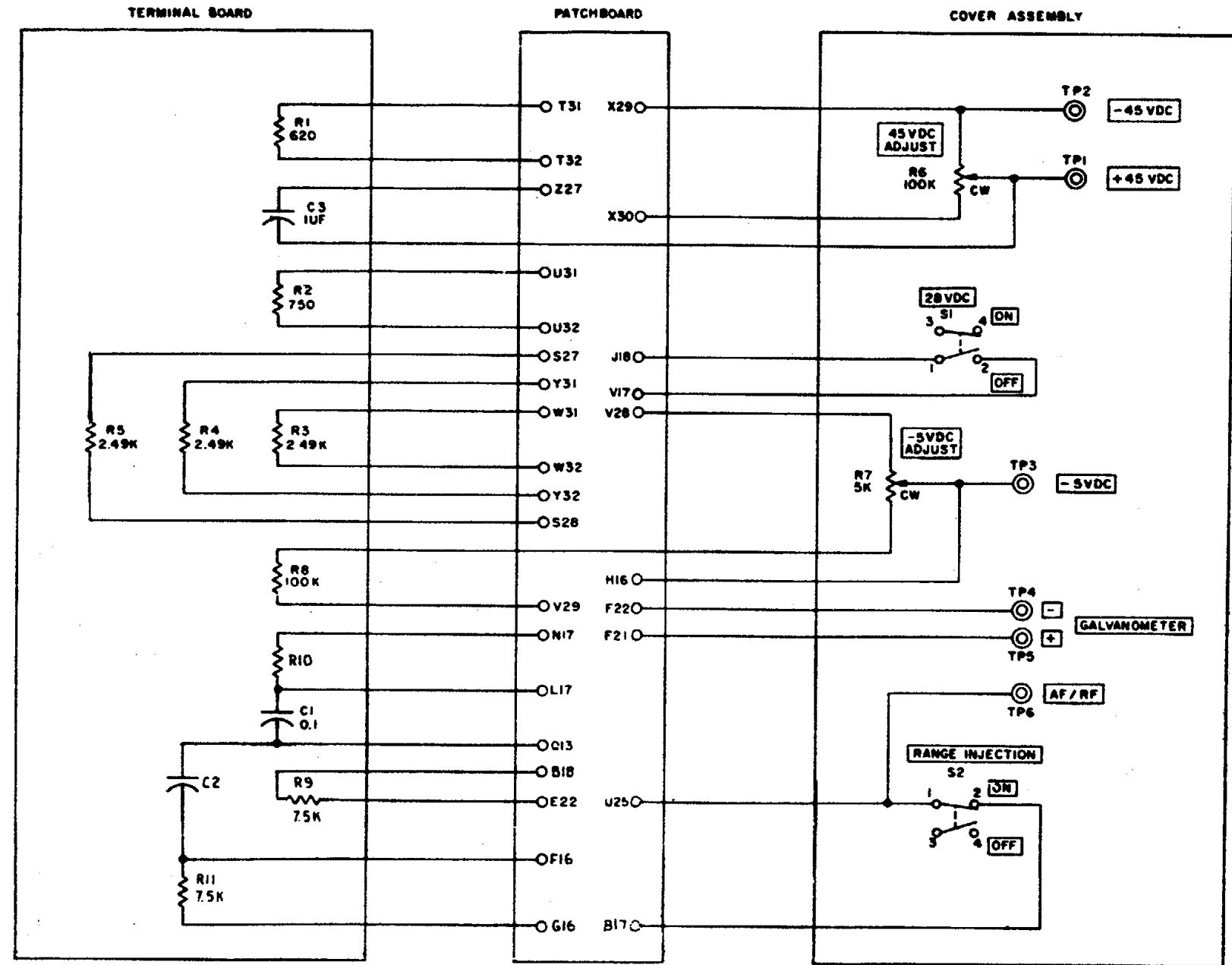

MI 70016B

NOTE: REFER TO APPENDIX B FOR SERIAL NUMBER EFFECTIVITY.

Figure 3-82. Pb HPI-517D 10173962 *(AB) (see note) (FG 1285)- schematic .

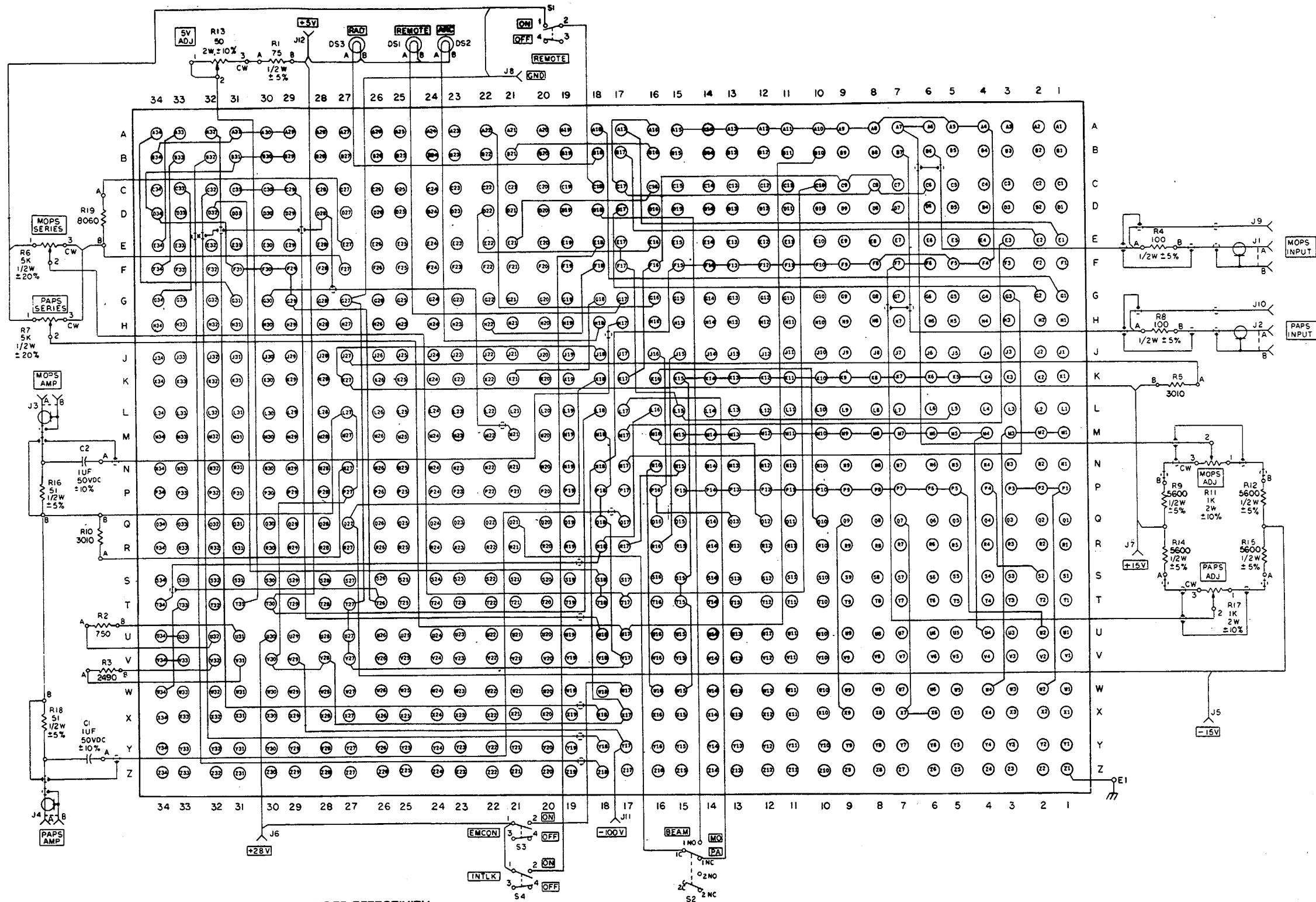

NOTE: REFER TO APPENDIX B FOR SERIAL NUMBER EFFECTIVITY.

MS 432491A

Figure 3-83. Pb HPI-520B 11567799 *(AV) (see note) (FG 1290)- schematic .

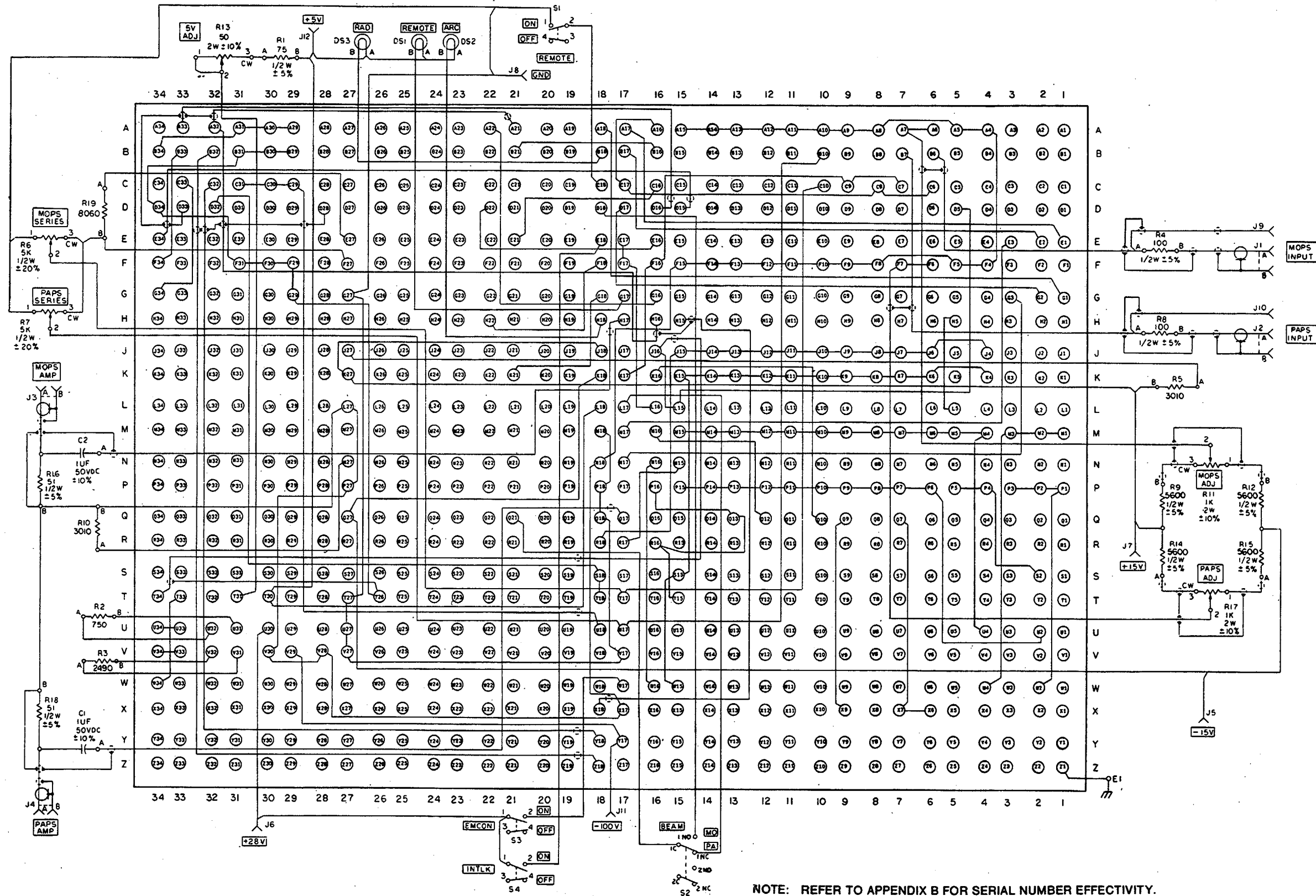

Figure 3-84. Pb HPI-502C 13385013*(AB) (see note) (FG 1200)- schematic .

MS 605256

WIRING TABLE		WIRING TABLE		WIRING TABLE		WIRING TABLE	
FROM	TO	FROM	TO	FROM	TO	FROM	TO
A1	T17	D5	D6	J6	X19	P16	Q13
A2	A9	D6	D7	J9	Q19	P32	Q34
A2	C18	D7	DB	J10	Y19	P33	R34
A3	A10	DB	D9	J12	R20	P34	R33
A3	D18	D9	D10	J19	X24	Q2	T2
A4	A11	D10	D11	J21	K21	Q8	X9
A4	L17	D11	D12	K17	Q11	Q12	T15
A5	A12	D12	D13	L3	L11	Q14	V17
A5	H18	D16	Q16	L3	W1	Q17	V29
A6	A13	D19	H8	L4	S1	R16	U15
A6	J18	D20	J4	L5	L9	R23	W27
A7	A14	D22	J16	L5	V1	S19	U17
A7	K18	E4	M20	L6	L7	S25	Z25
A8	G20	E5	L19	L6	X1	S27	S28
A16	A22	E9	M19	L6	M16	S29	S30
A19	E7	E17	Q23	M3	V3	T15	U15
A32	B18	E20	H9	M4	X12	T33	T34
A33	A34	F4	G4	M8	U3	U17	V17
B2	F18	F6	G6	M9	R11	U28	Z27
B3	E18	F8	G8	M10	N6	U33	U34
B4	M17	F10	G10	M12	T12	V28	V30
B5	S18	F13	G13	M16	Q10	V28	Y29
B6	M18	F17	J8	N1	N2	V33	V34
B7	L18	F19	J7	N1	S4	W30	X27
B8	H12	F20	J11	N3	N8	W33	W34
B16	L16	F21	G16	N3	U4	X7	X8
B18	C1	F22	X27	N4	N13	X7	X9
B19	E6	G6	T19	N6	U6	X30	Z27
B20	F10	G8	J20	N9	U10	X33	X34
B20	H20	G17	Y30	N13	V6	Y24	Y25
C2	Y17	G19	J2	N16	P16	Y33	Y34
C3	G18	G21	M21	P1	P2	Z25	Z27
C16	D21	H4	H12	P1	X3	Z1	GRD
C19	H12	H11	S20	P3	U12		
C20	J3	H19	S19	P8	X6		
D3	N20	H22	U25	P9	Y6		
D3	D4	J1	K19	P11	V12		
D4	D5	J5	U19	P13	X13		

↓ SHIELDED TO D34
 ↓ SHIELDED TO B16
 ↓ SHIELDED TO V17
 ↓ SHIELDED TO H19

NOTE: REFER TO APPENDIX B FOR SERIAL NUMBER EFFECTIVITY.

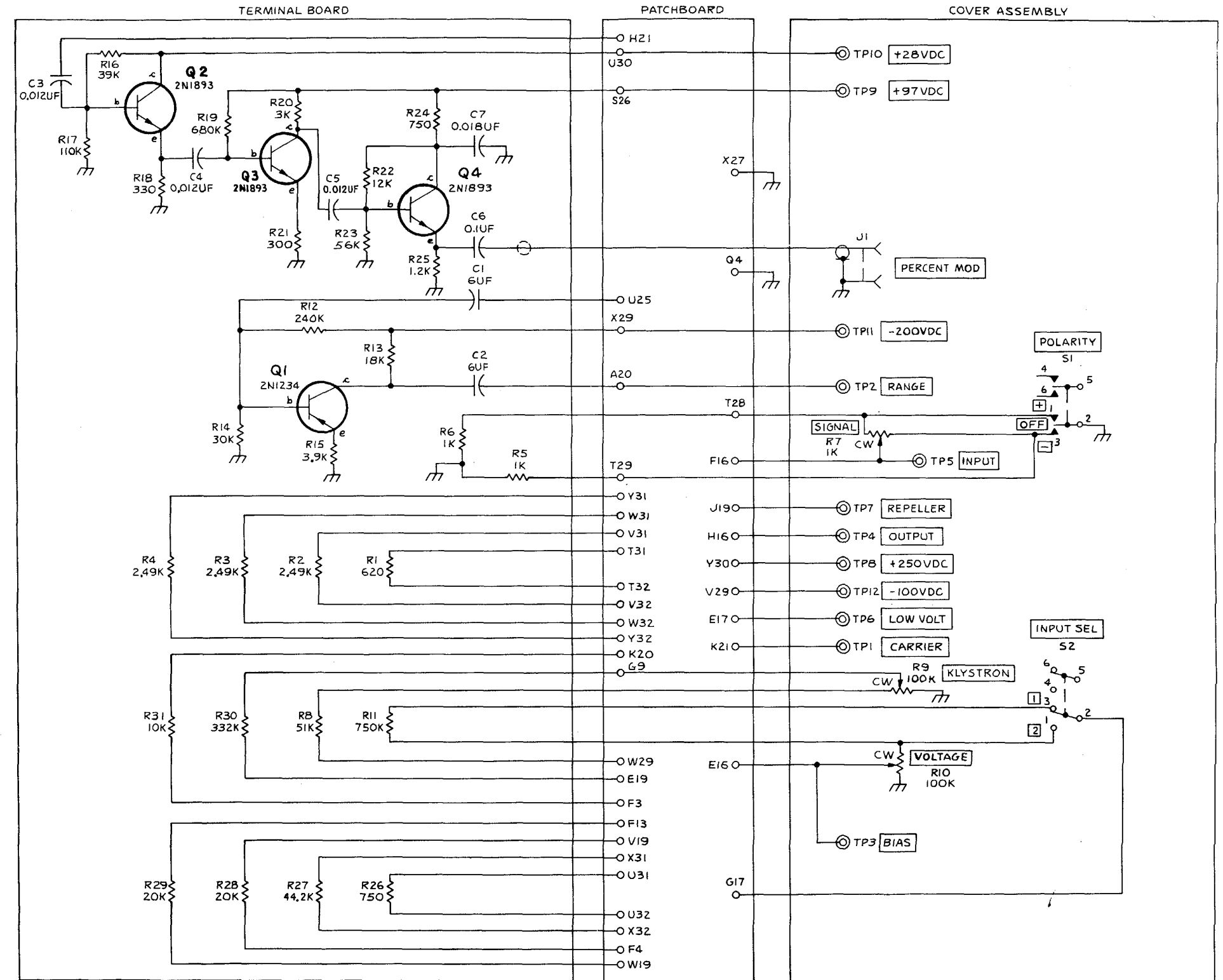

MI 70019E

Figure 3-85. Pb HPI-523 10174862*(AB) (see note) (FG 1300) - schematic

WIRING TABLE	
PIN NO.	
FROM	TO
A1	A2
A1	G1
A2	A3
A17	C5
A21	A32
A24	P23
A33	A34
B17	C7
B23	B24
B24	P24
C4	C5
C4	G4
C6	C7
C7	G6
C8	C9
C8	G8
C9	C17
C23	Q24
D17	G5
E17	F7
F4	F5
F5	G5
F6	G7
F7	G7
F8	G9
F9	F17
F9	G9
F16	Z25
F21	K16
F22	L16
G1	G17
G2	H2
G3	H3
H1	H2
H1	P23
H3	Q23

WIRING TABLE	
PIN NO.	
FROM	TO
H16	H17
J17	P17
K1	K2
K2	K3
K3	K4
K4	K5
K5	K6
K6	K7
K7	K8
K8	K9
K9	K10
K10	M15
L1	L2
L2	L3
L3	L4
L4	L5
L5	L6
L6	L7
L7	L8
L8	L9
L9	L10
L10	N15
M23	X24
P17	Q12
Q2	S2
Q4	S3
Q6	R6
Q13	R16
Q24	Y27
S2	X1
S3	W4
X23	Z27
Y25	Z25
Y23	Y25
Z24	Z27
Z1	GRD

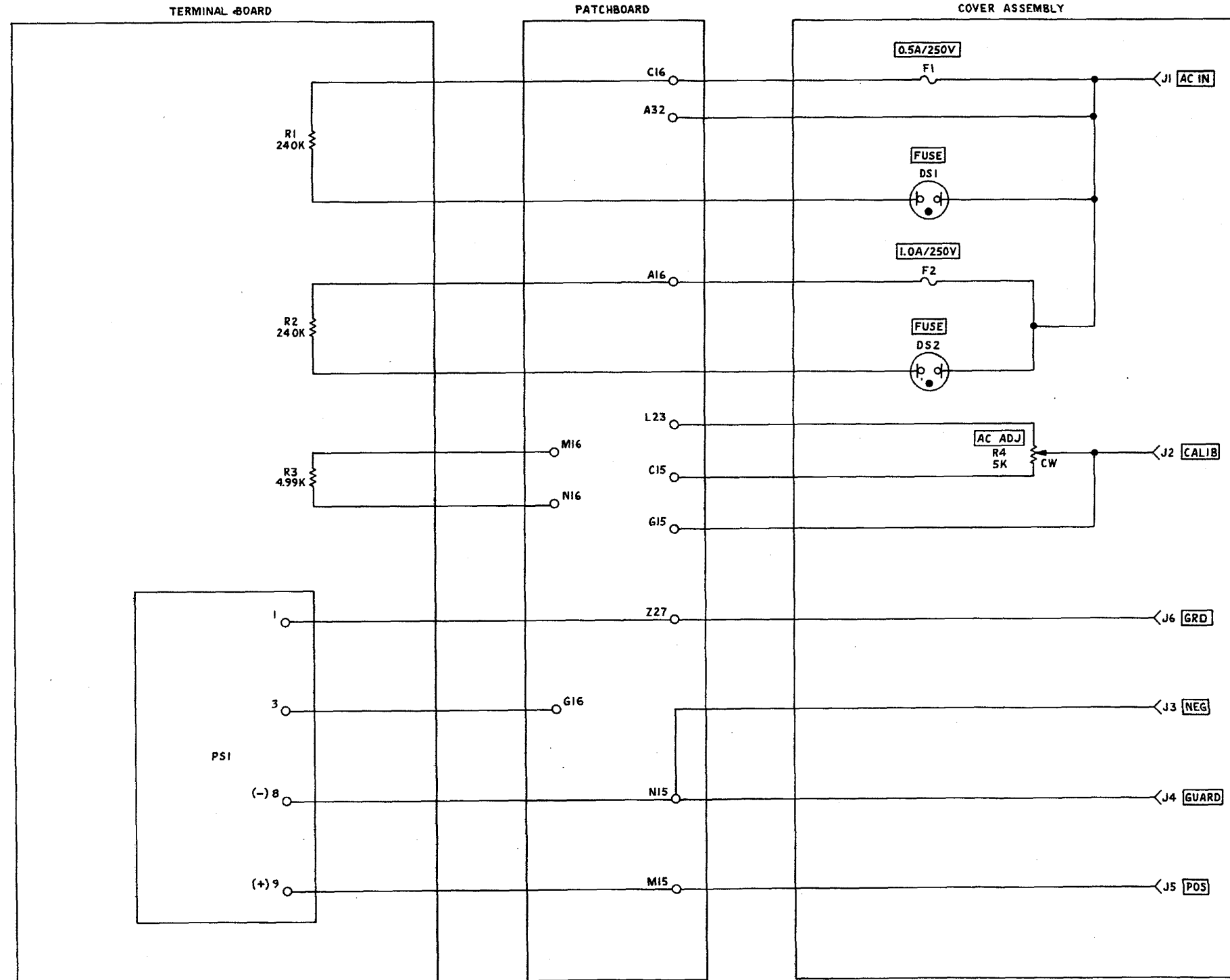

MI 70020

Figure 3-86. Pb HPI-526 10180531 (FG 1750)-schematic.
3-138

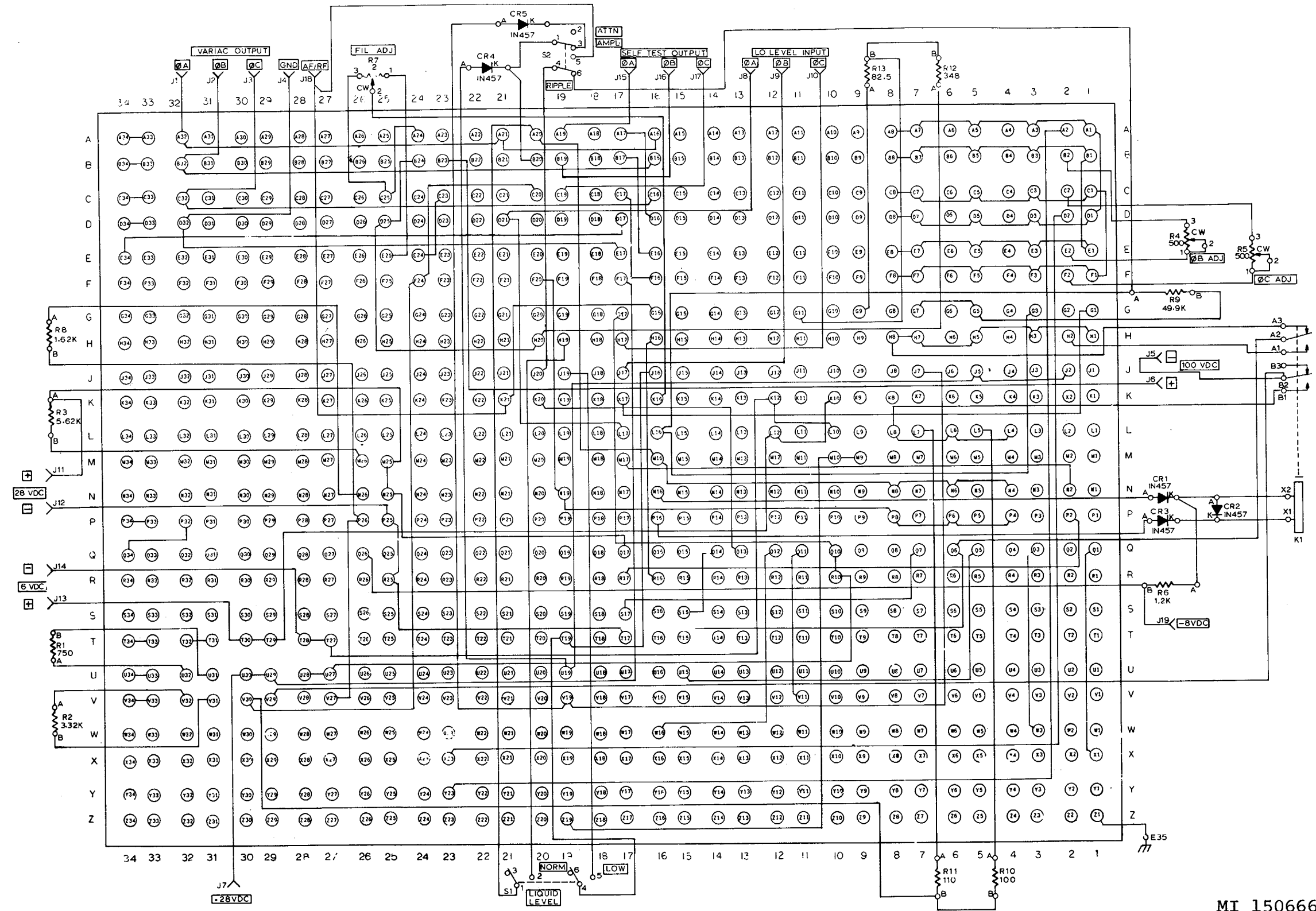

MI 150666

Figure 3-87. Pb HP17-105A 10676961 (FG 1330) - schematic.
3-139

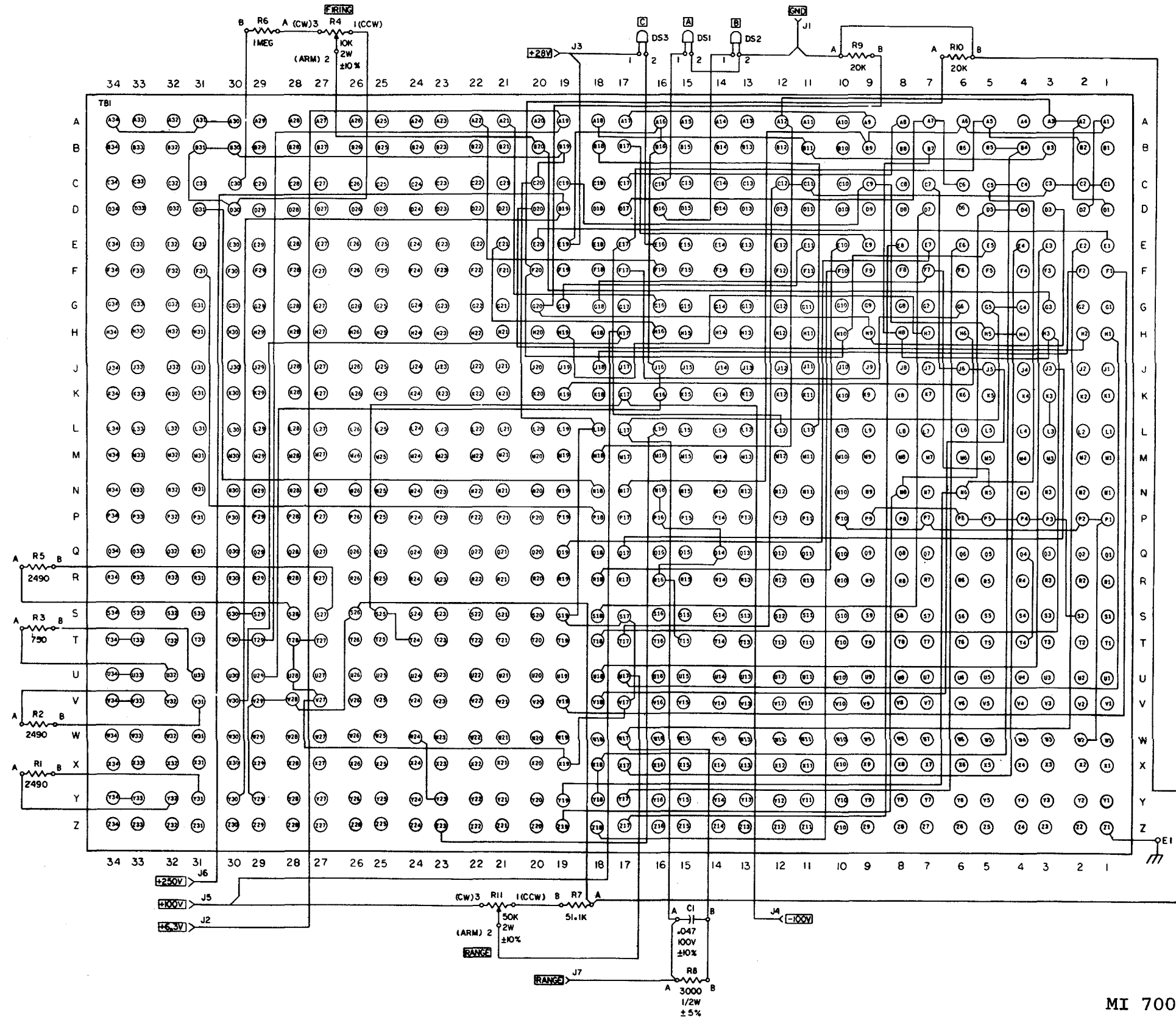

MI 70021

Figure 3-88. Pb HPI8-101 10670299 (fg 1755)-schematic.
3-140

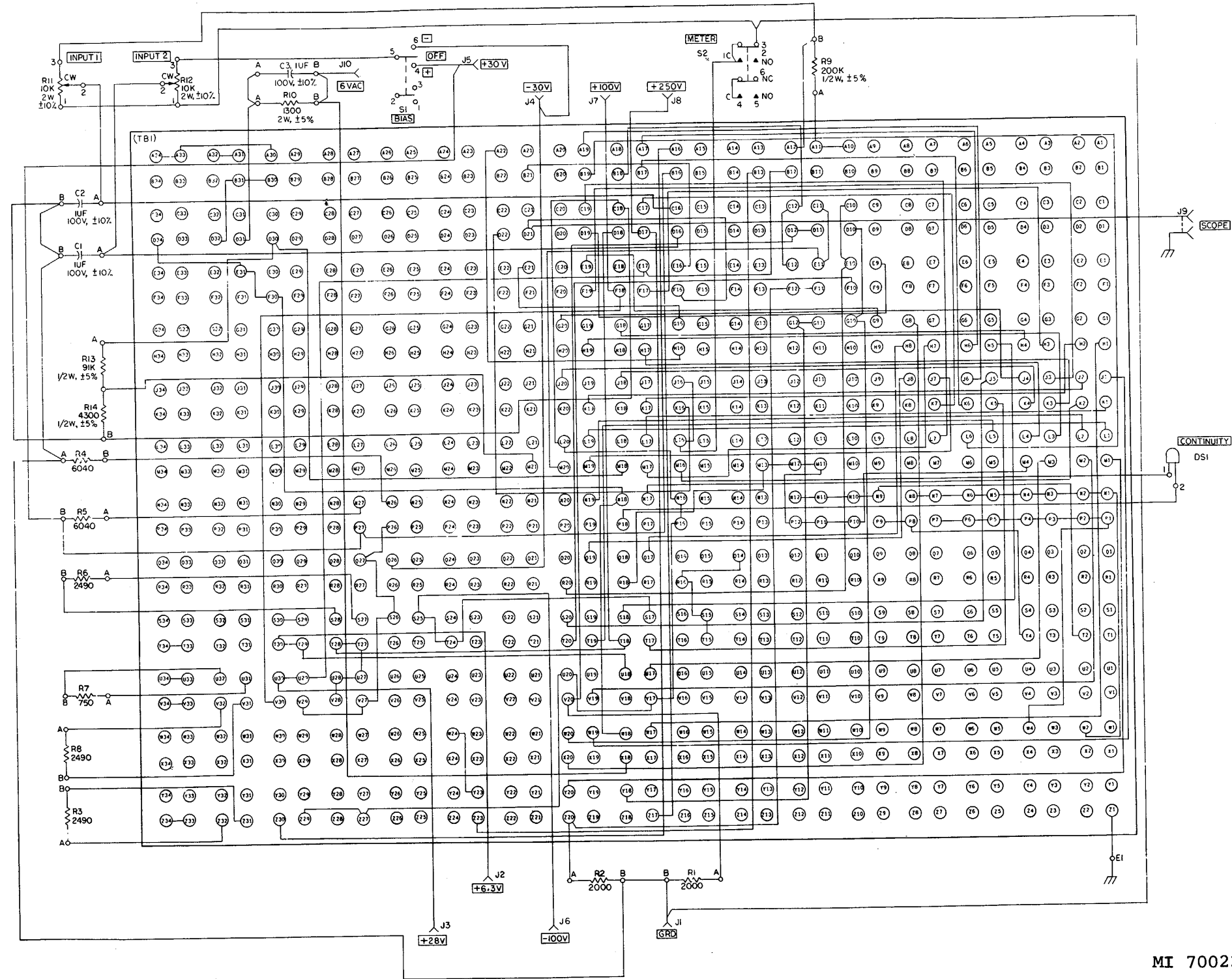

MI 70022A

Figure 3-89. Pb HPI8-102 1066304 9FG 1760)-schematic.

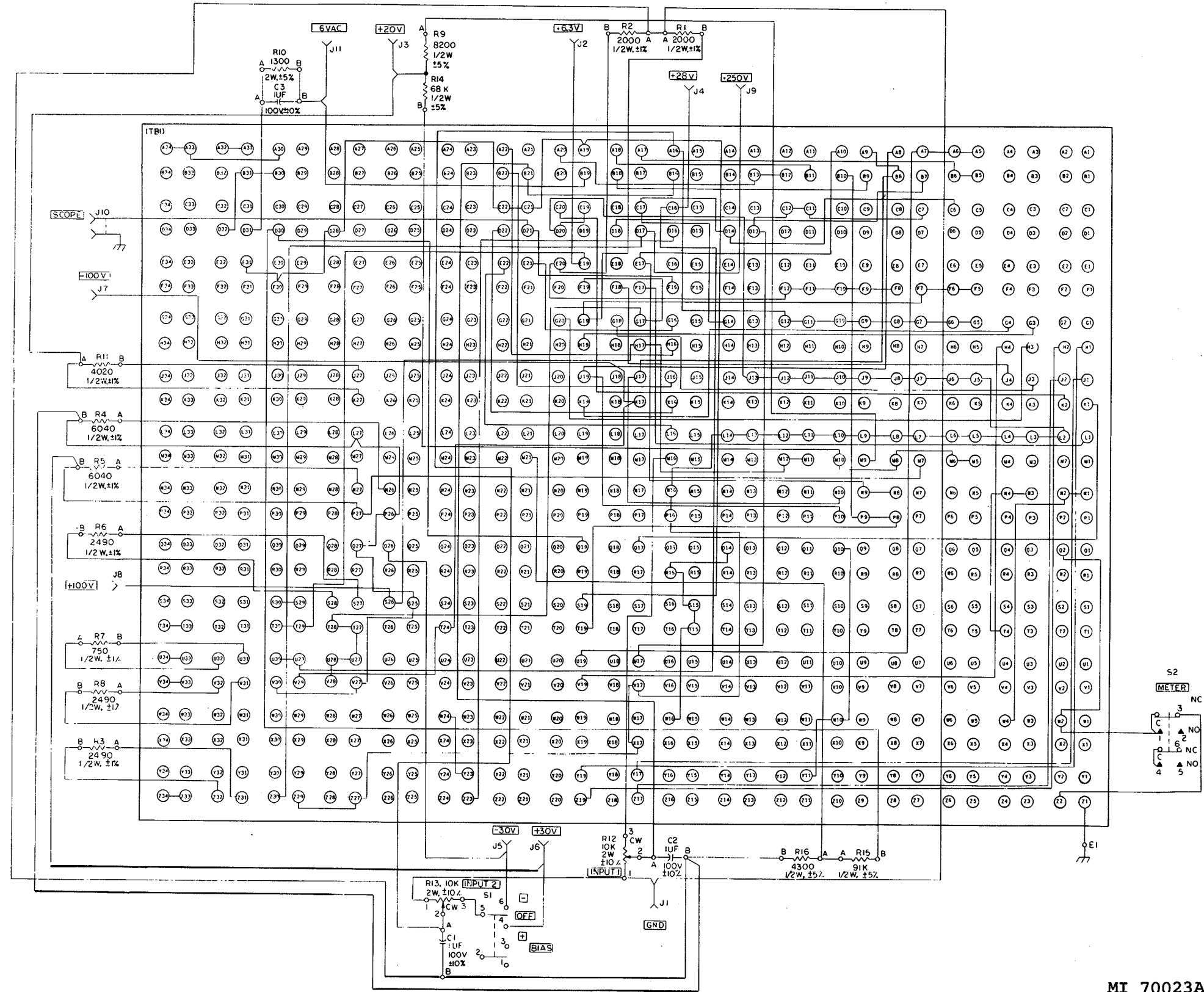

MI 70023A

Figure 3-90. Pb HPI8-103 10669248 (FG 1765)-schematic.

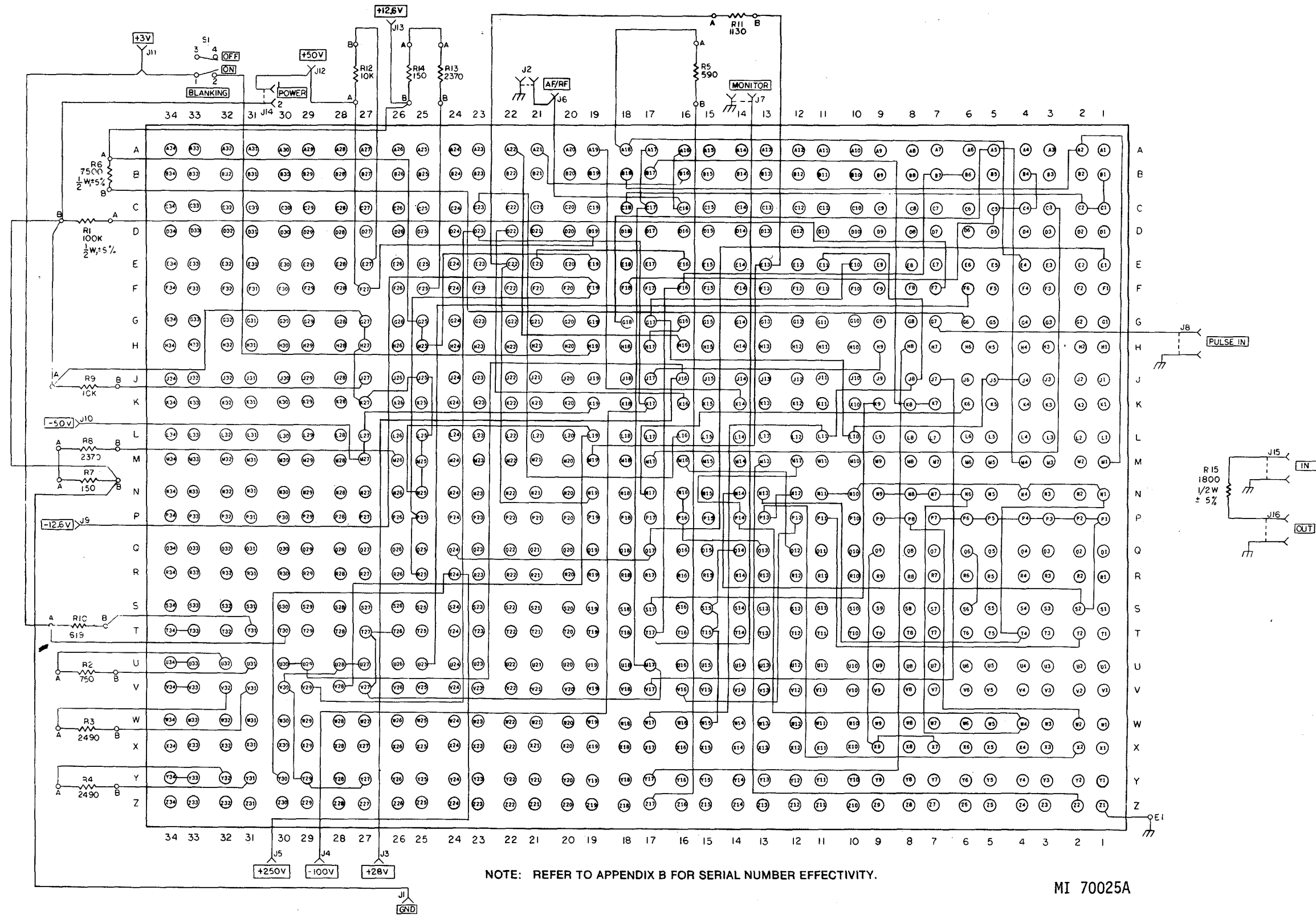
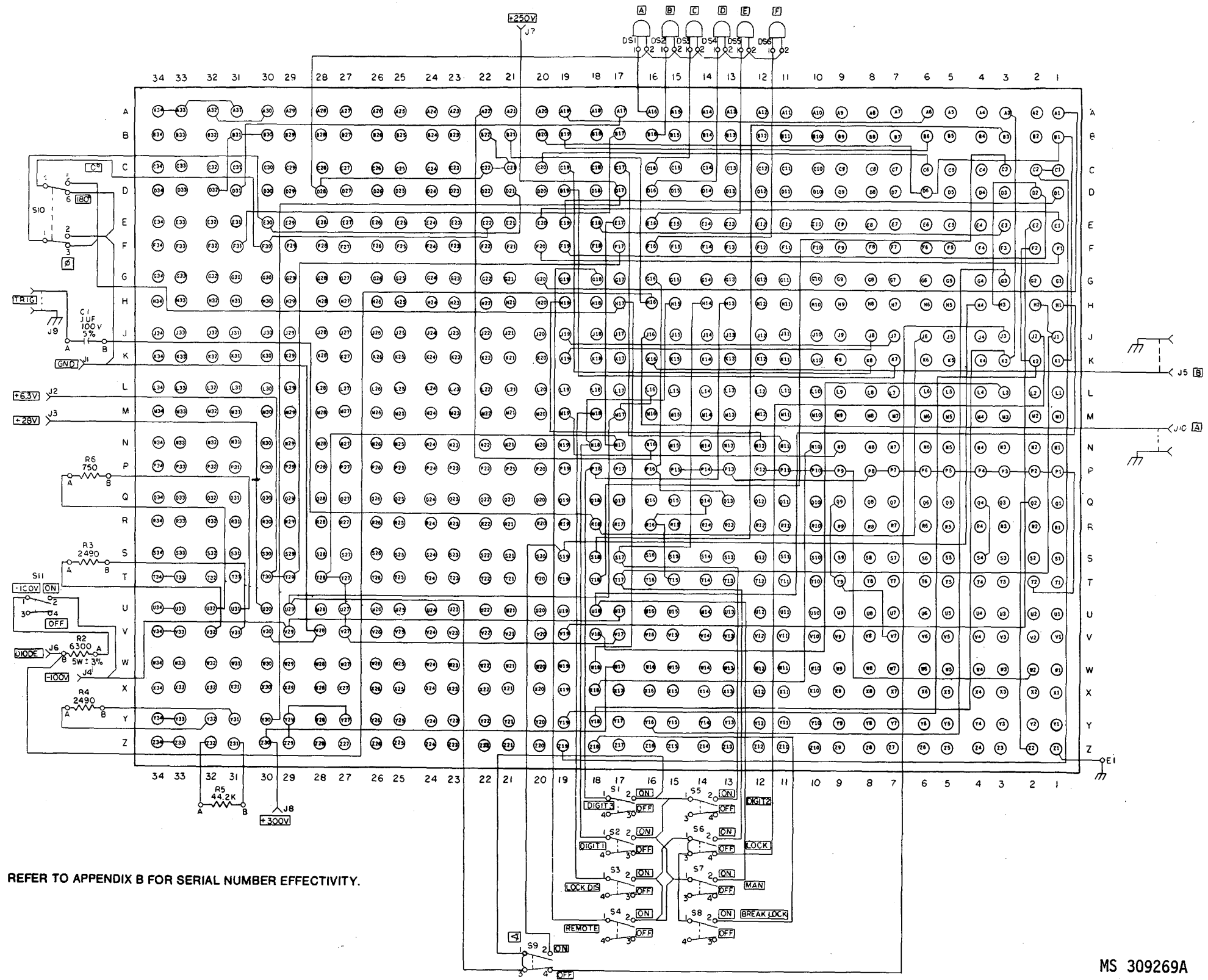

Figure 3-92. Pb HPI8-106 10671762 * (AB) (see note) (FG 1775)-schematic.



NOTE: REFER TO APPENDIX B FOR SERIAL NUMBER EFFECTIVITY.

MS 309269A

Figure 3-93. Pb HPI8-107 106671763 * (AB) (see note) (FG 1780)-schematic.

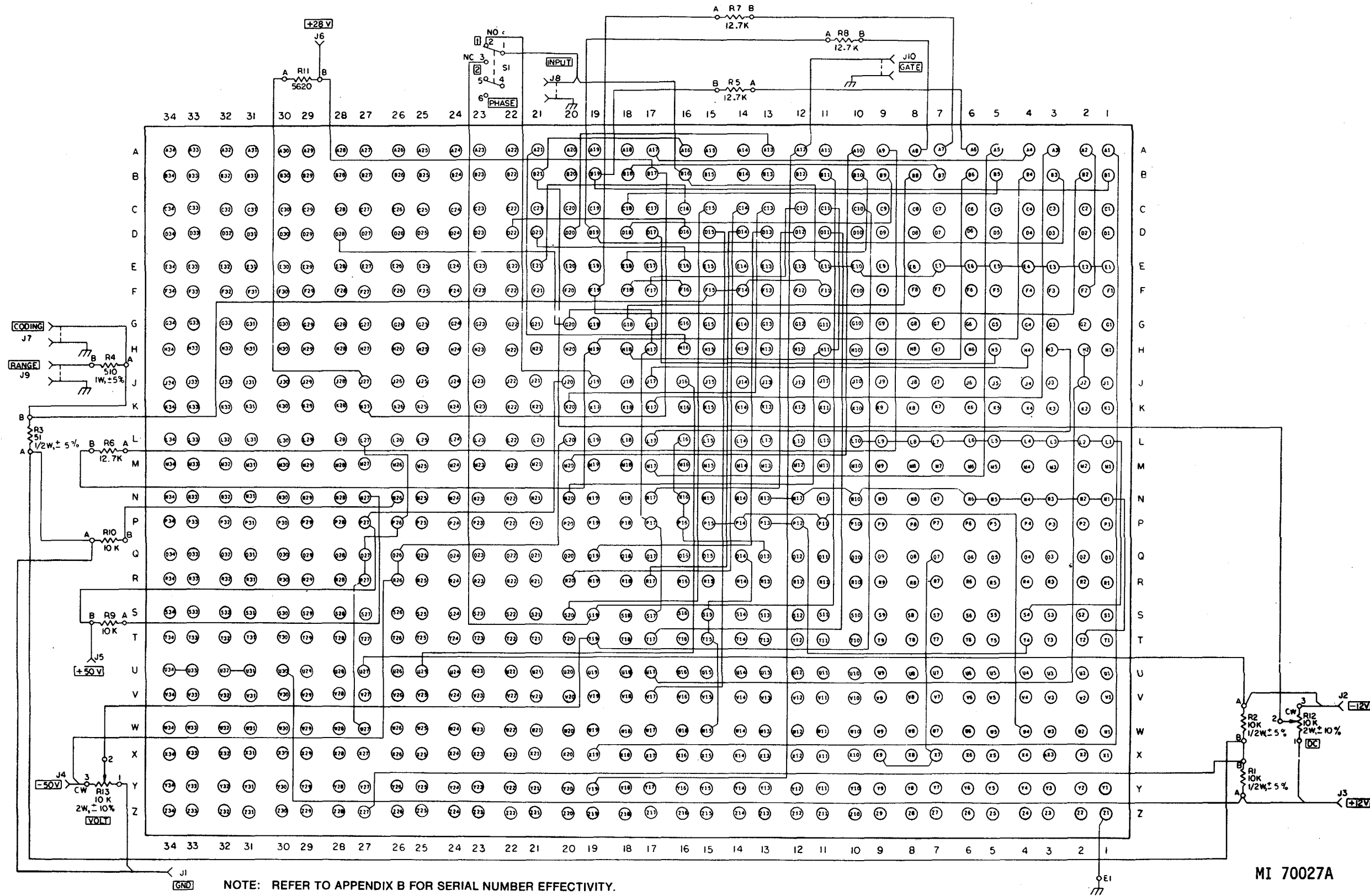
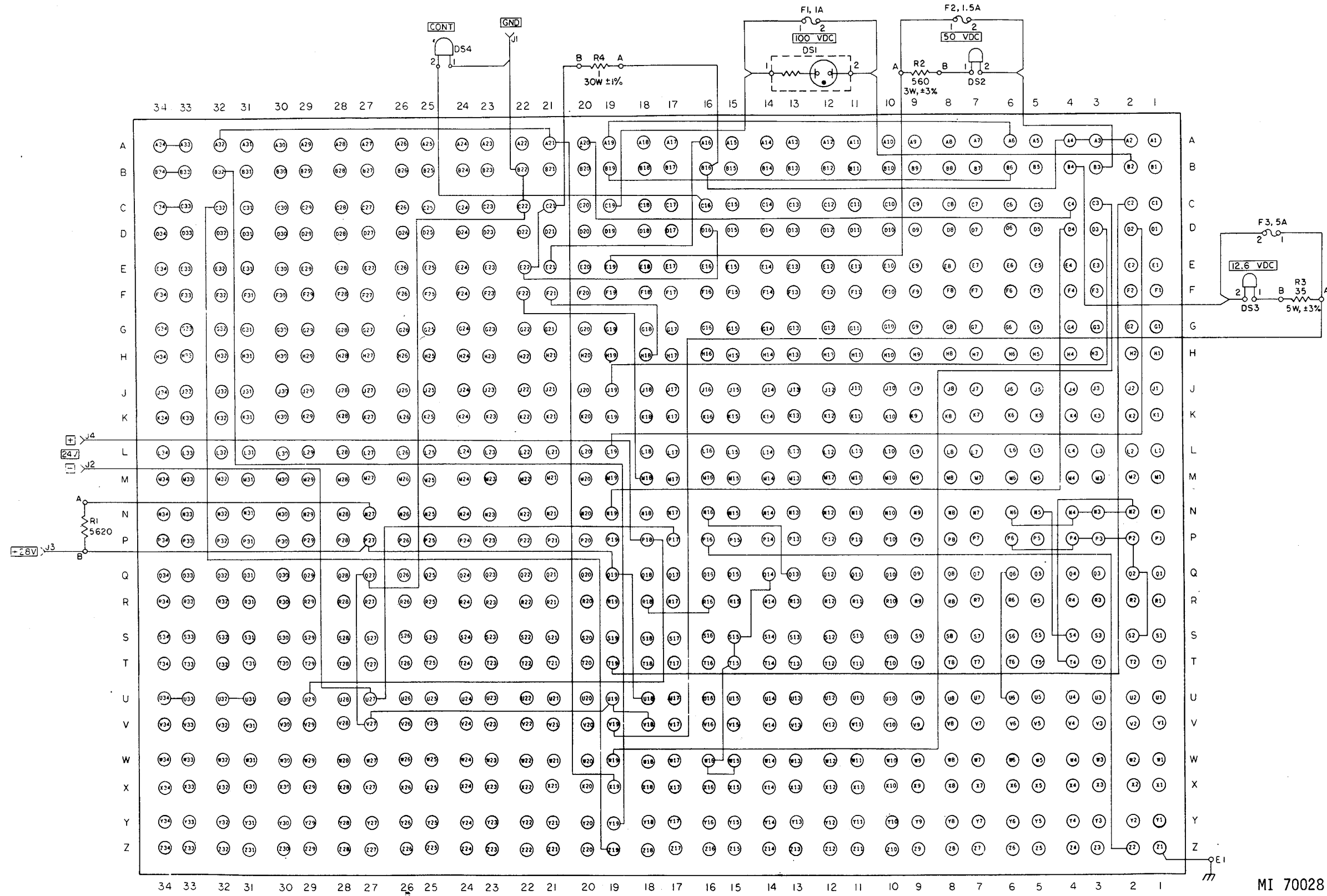
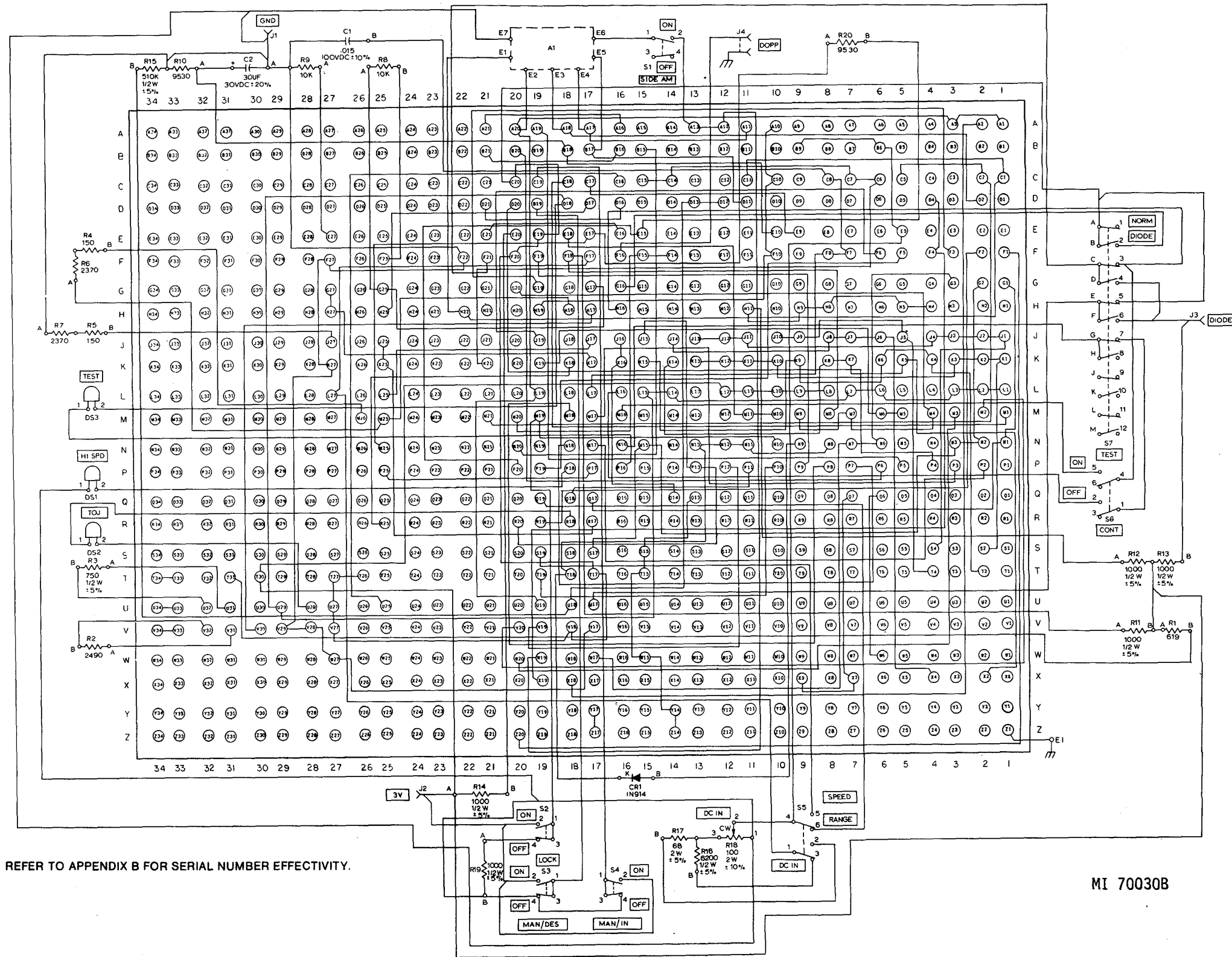

Figure 3-94. Pb HPI8-108 10671764 * (AB) (see note) (FG 1785)-schematic.



MI 70028

Figure 3-94. Pb HPI8-109 10670449 * (AB) (see note) (FG 1790)-schematic.



NOTE: REFER TO APPENDIX B FOR SERIAL NUMBER EFFECTIVITY.

Figure 3-96. Pb HPI8-1010A 10669031 * (AB) (see note) (FG 1795)-schematic.

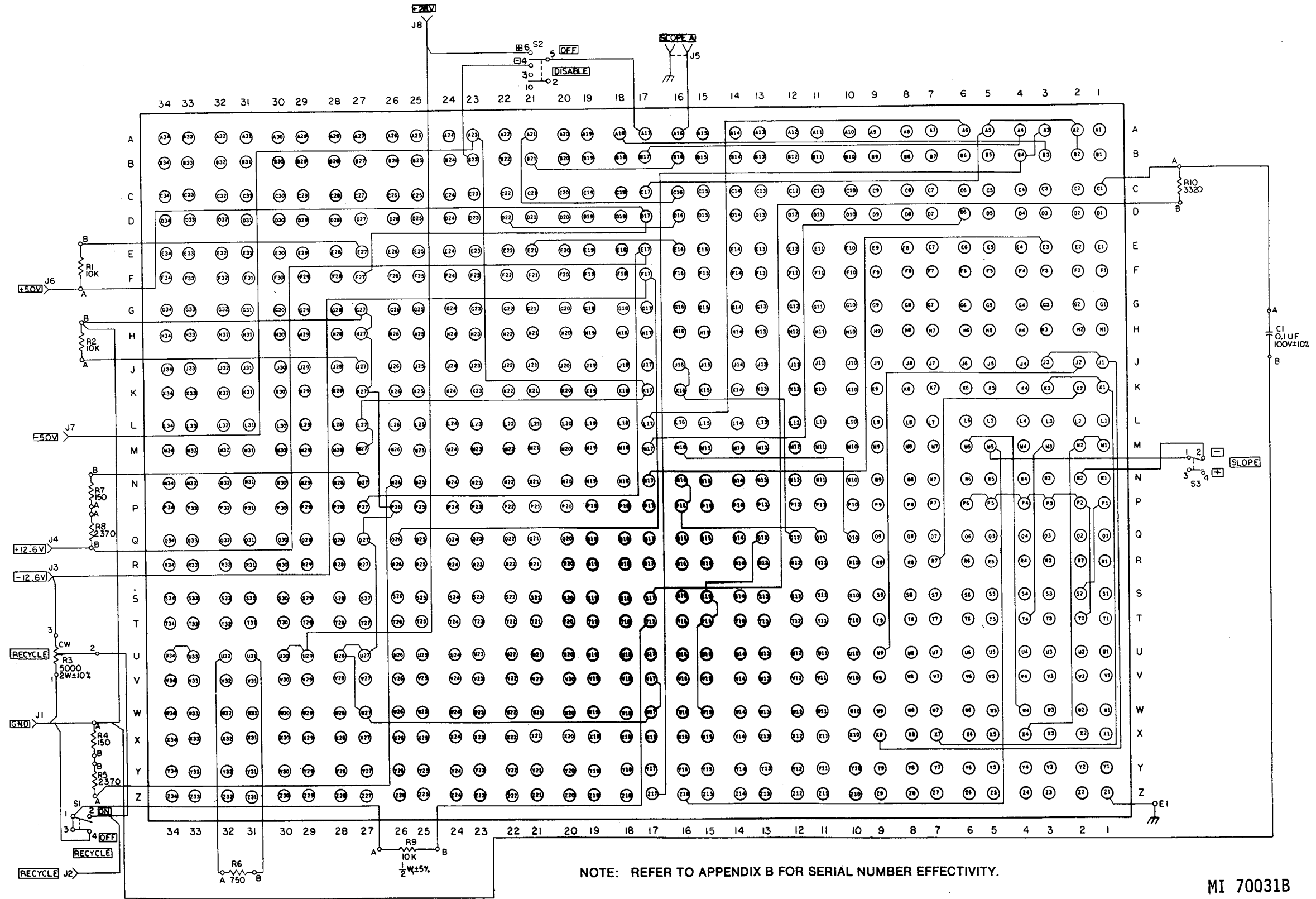
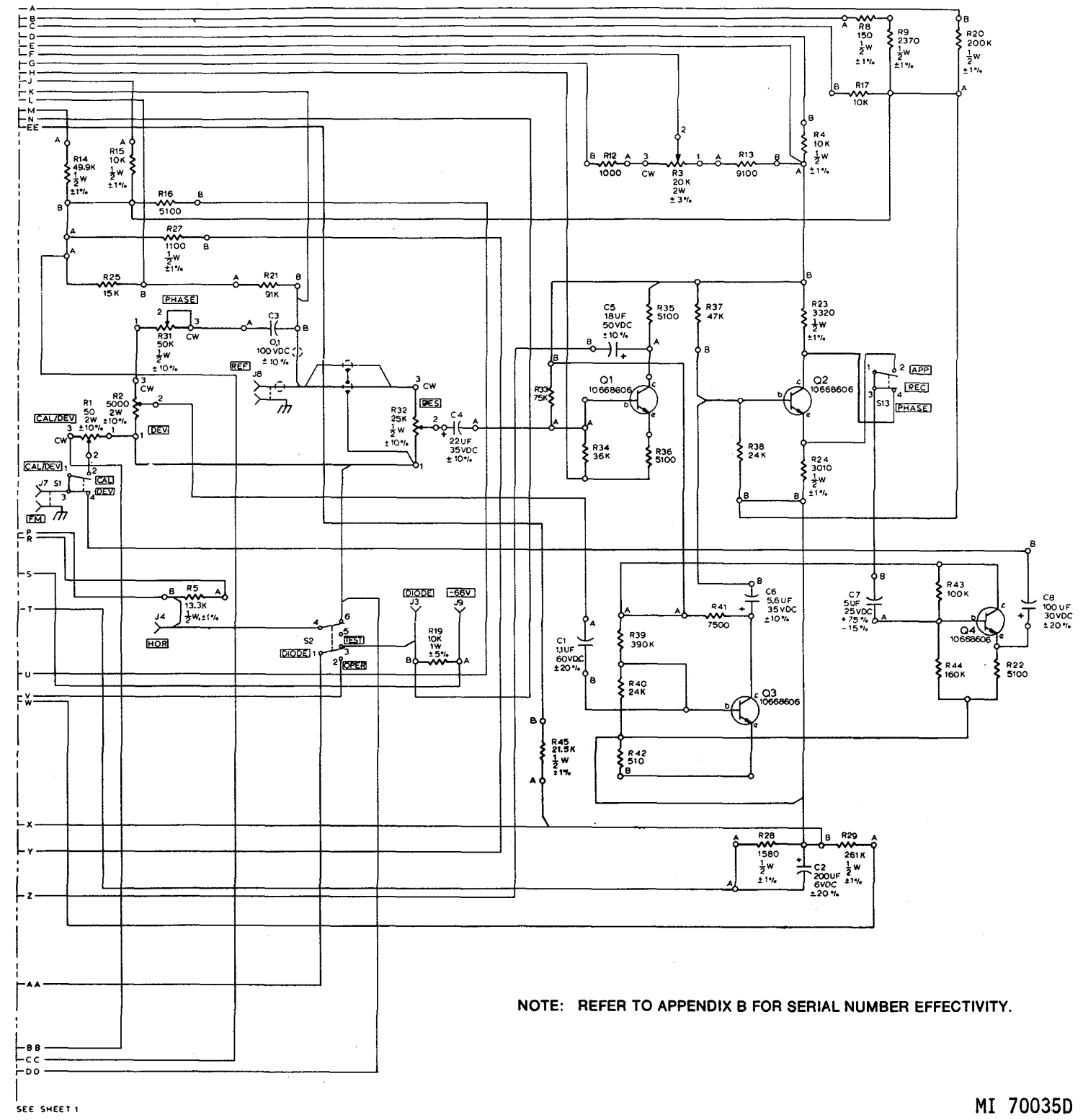
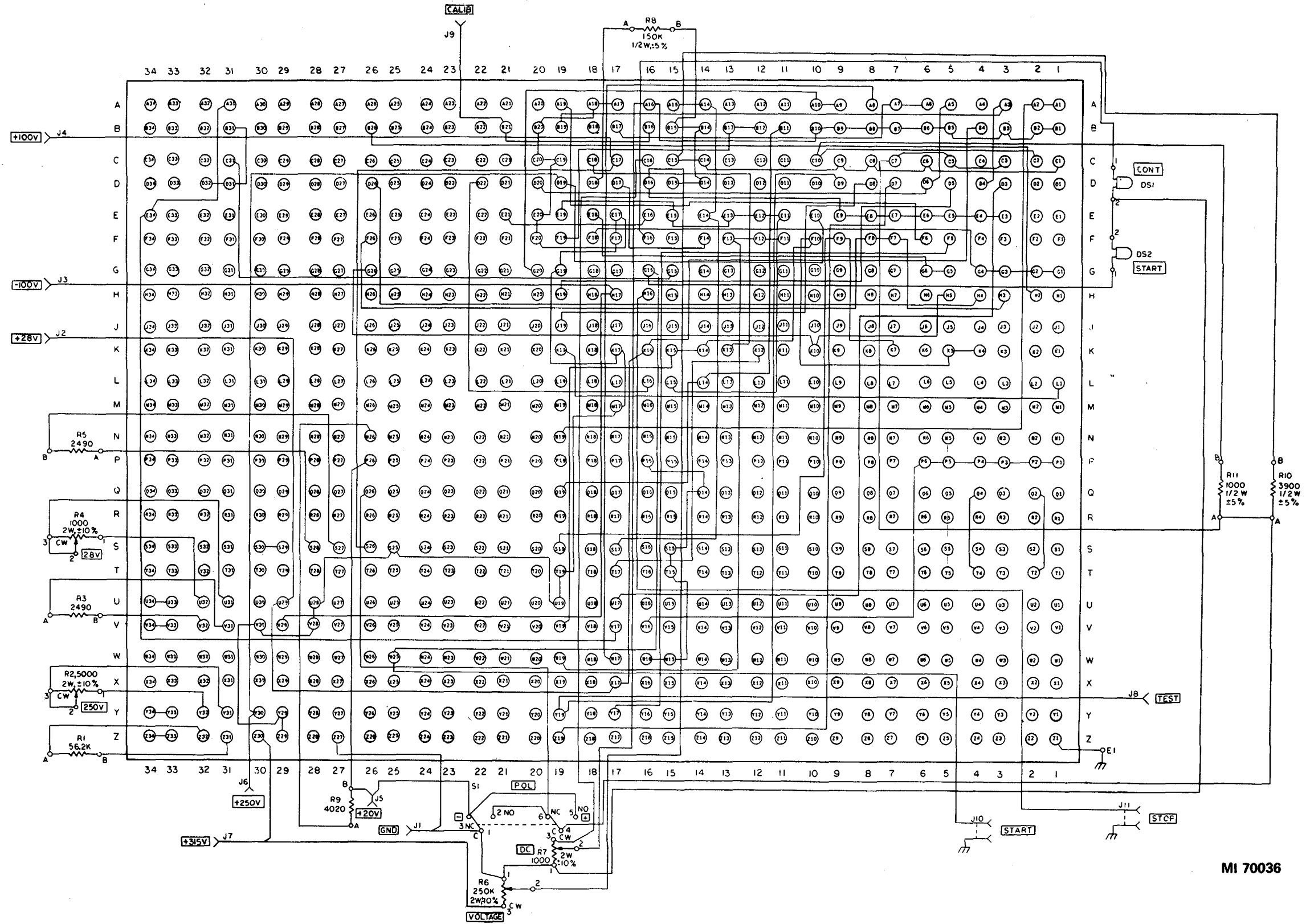

Figure 3-97. Pb HPI8-1011 10671766 * (AB) (see note) (FG 1800)-schematic.



MI 70035D

Figure 3-98. Pb HPI8-1012A 10669027 * (AB) (see note) (FG 1805)-schematic (sheet 2 of 2) .



MI 70036

Figure 3-99. Pb HPI8-1013 10671768 * (FG 1800)-schematic.

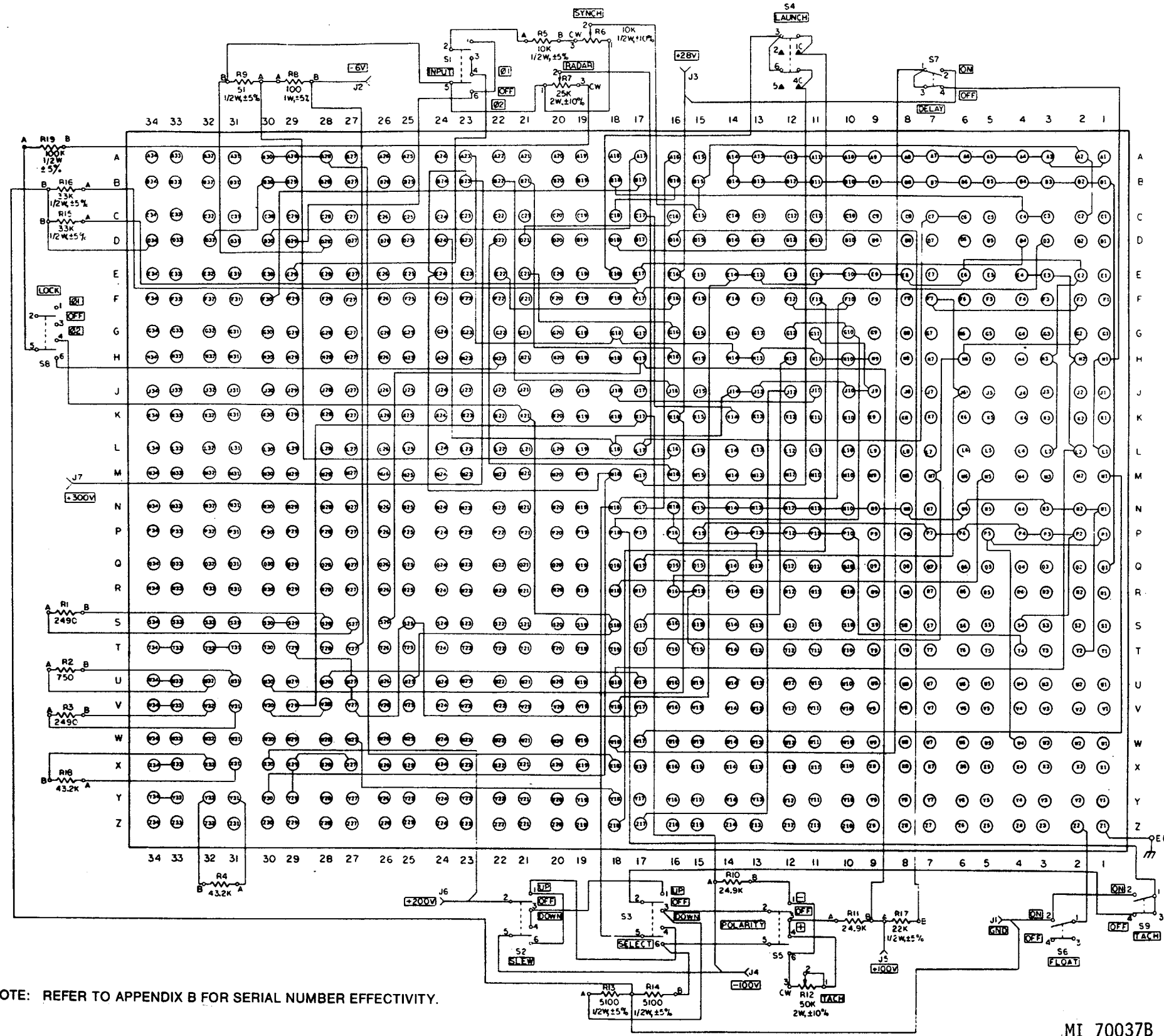

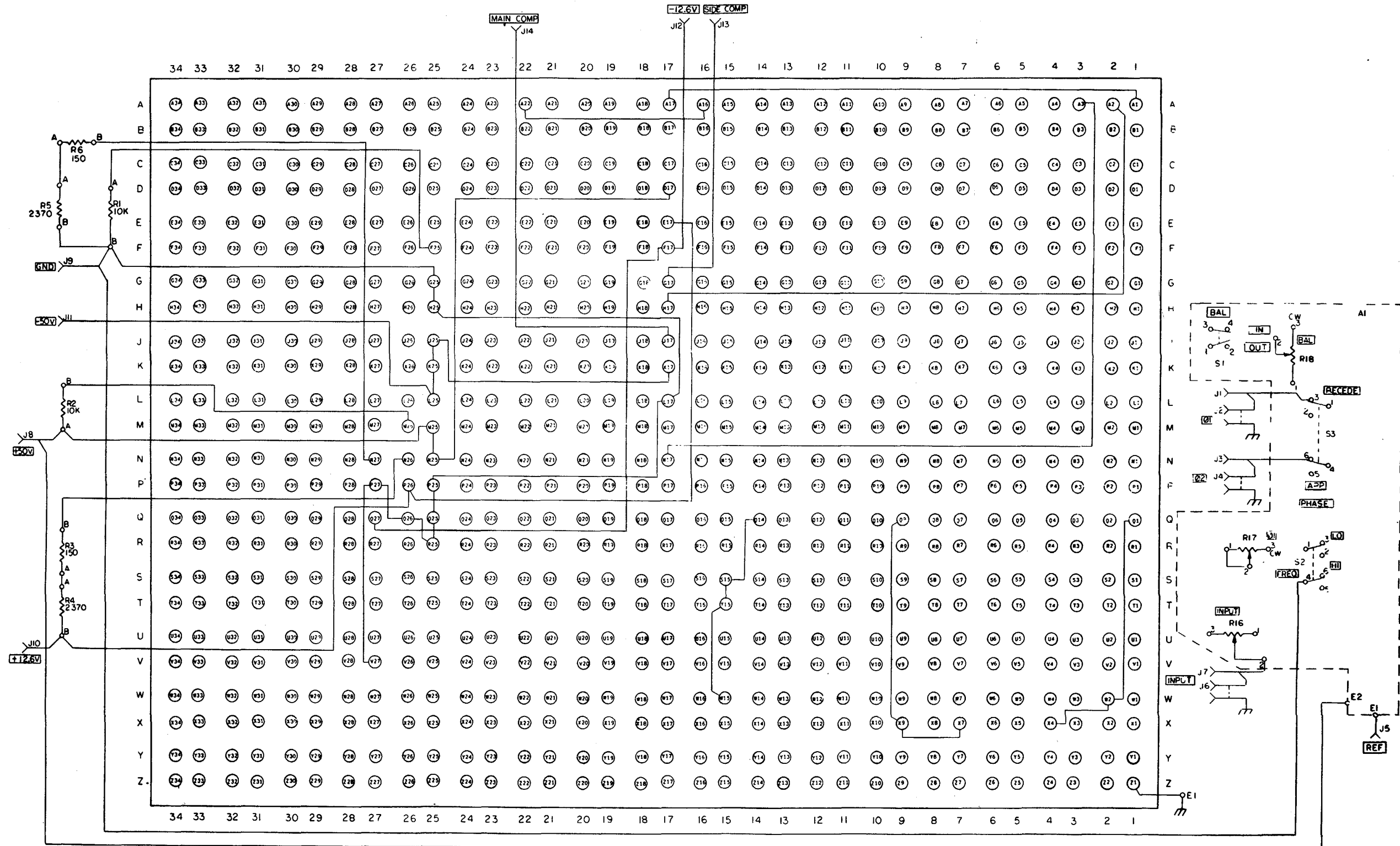

NOTE: REFER TO APPENDIX B FOR SERIAL NUMBER EFFECTIVITY.

MI 70038A

Figure 3-101. Pb HPI8-1016 10671605 * (AB) (see note) (FG 1825)-schematic. (sheet 1 of 2)

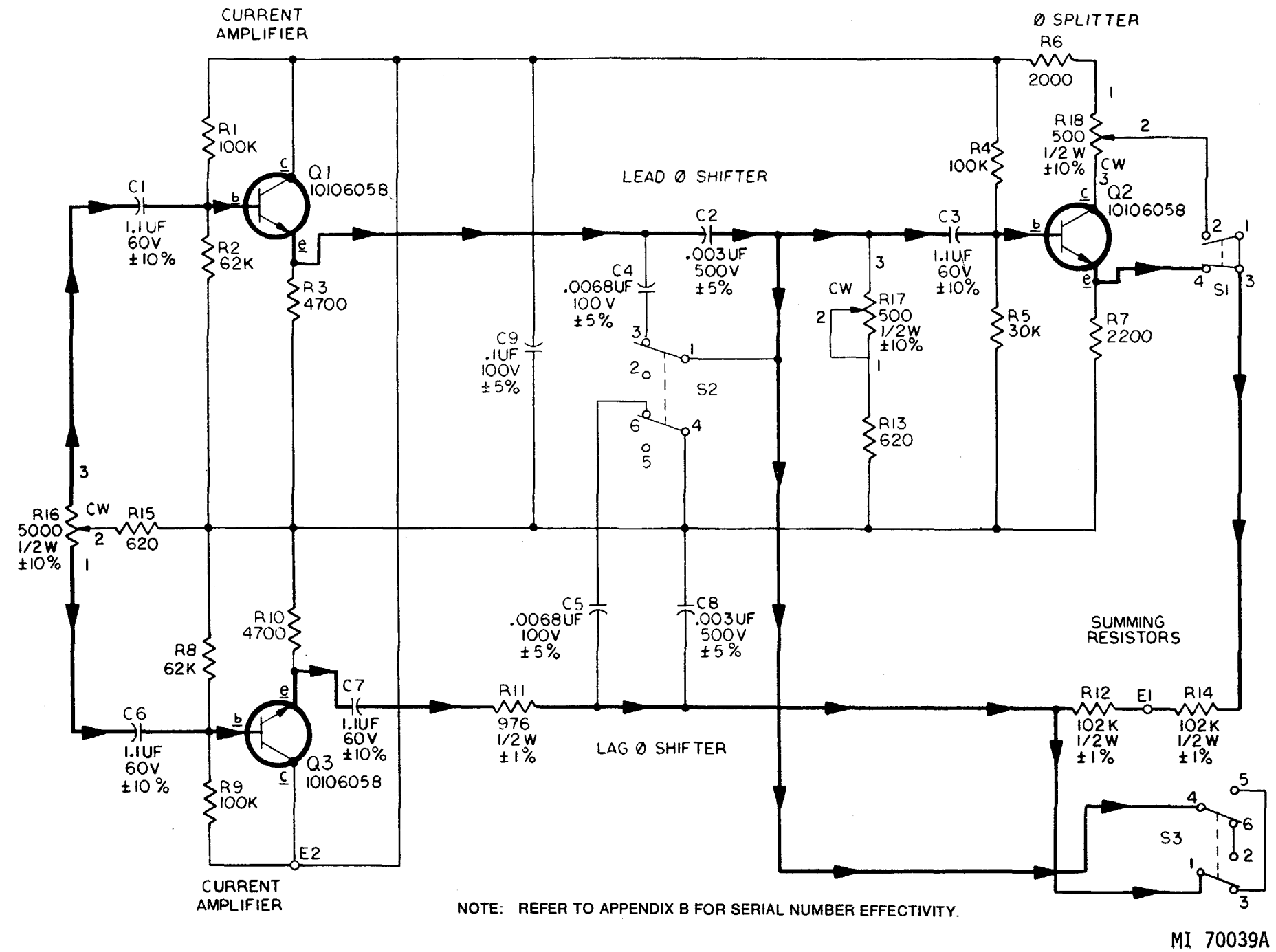

Figure 3-101. Pb HPI8-1016 10671605 * (AB) (see note) (FG 1825)-schematic (sheet 2 of 2)

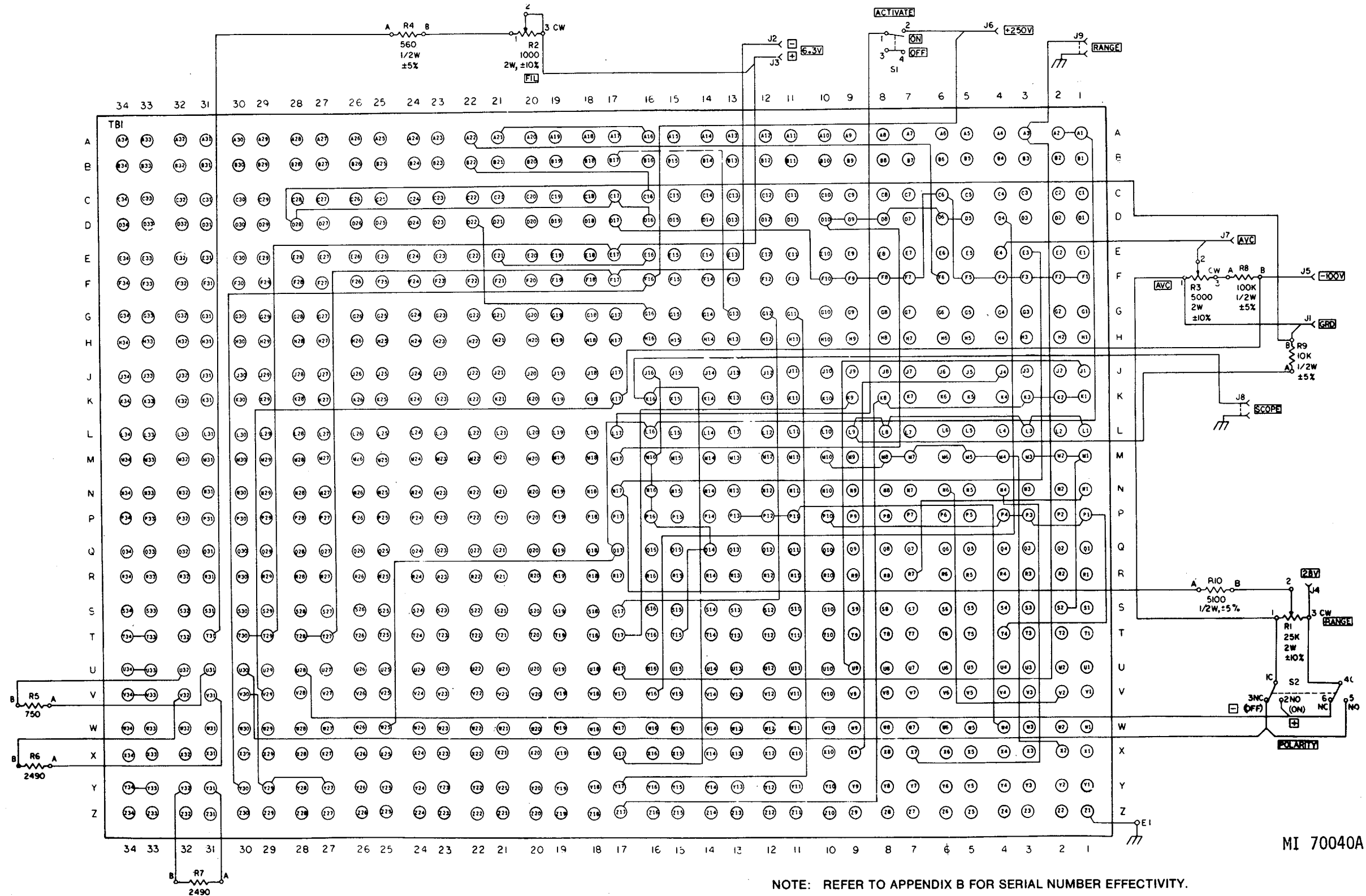
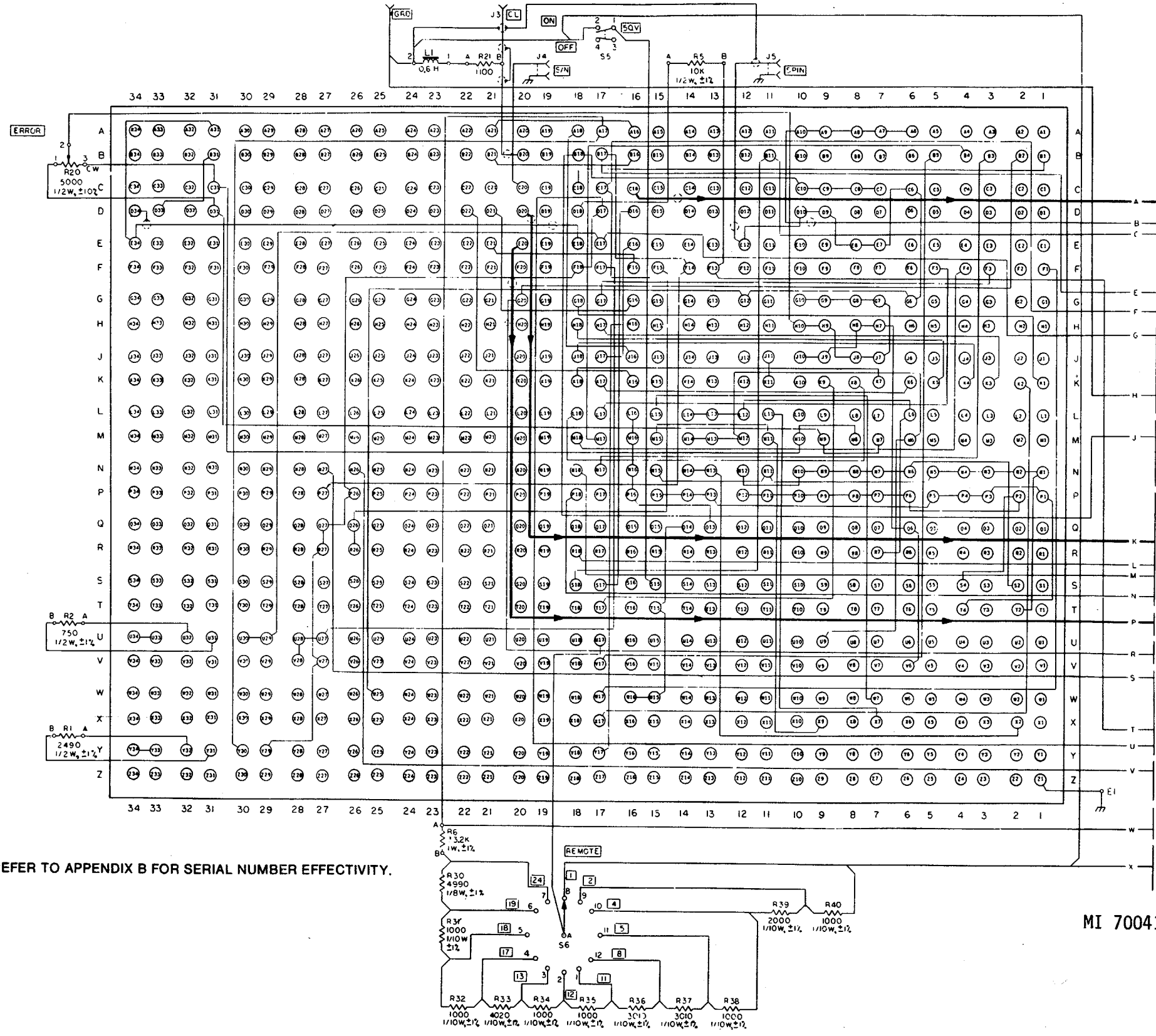

Figure 3-102. Pb HPI8-1017 10670298 * (AB) (see note) (FG 1815)-schematic.



NOTE: REFER TO APPENDIX B FOR SERIAL NUMBER EFFECTIVITY.

MI 70041A

Figure 3-101. Pb HPI8-1016 10671605 * (AB) (see note) (FG 1825)-schematic. (sheet 1 of 2)

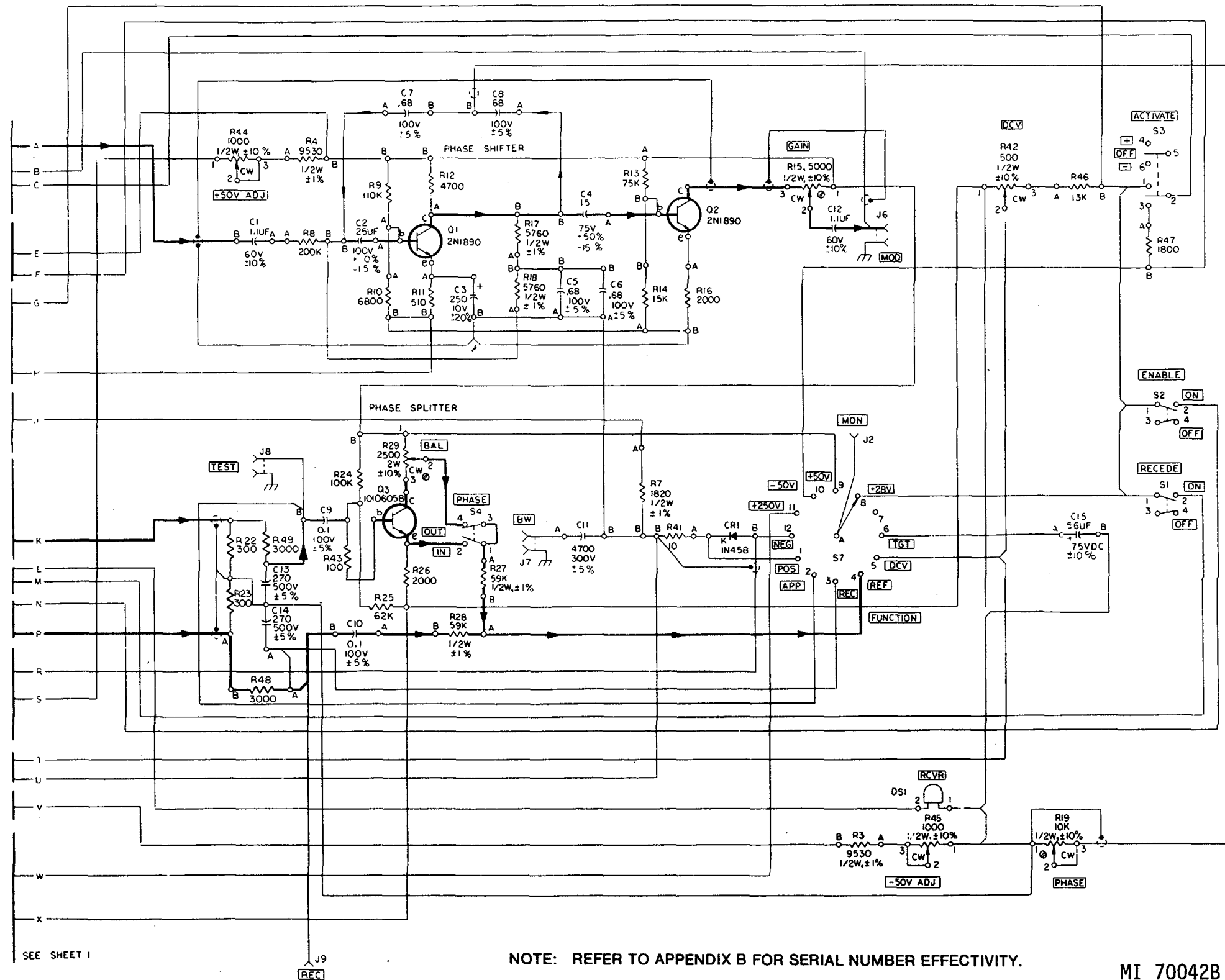

Figure 3-103. Pb HPI8-1018 10671770 *(AB) (see note) (FG 1850) - schematic (sheet 2 of 2).

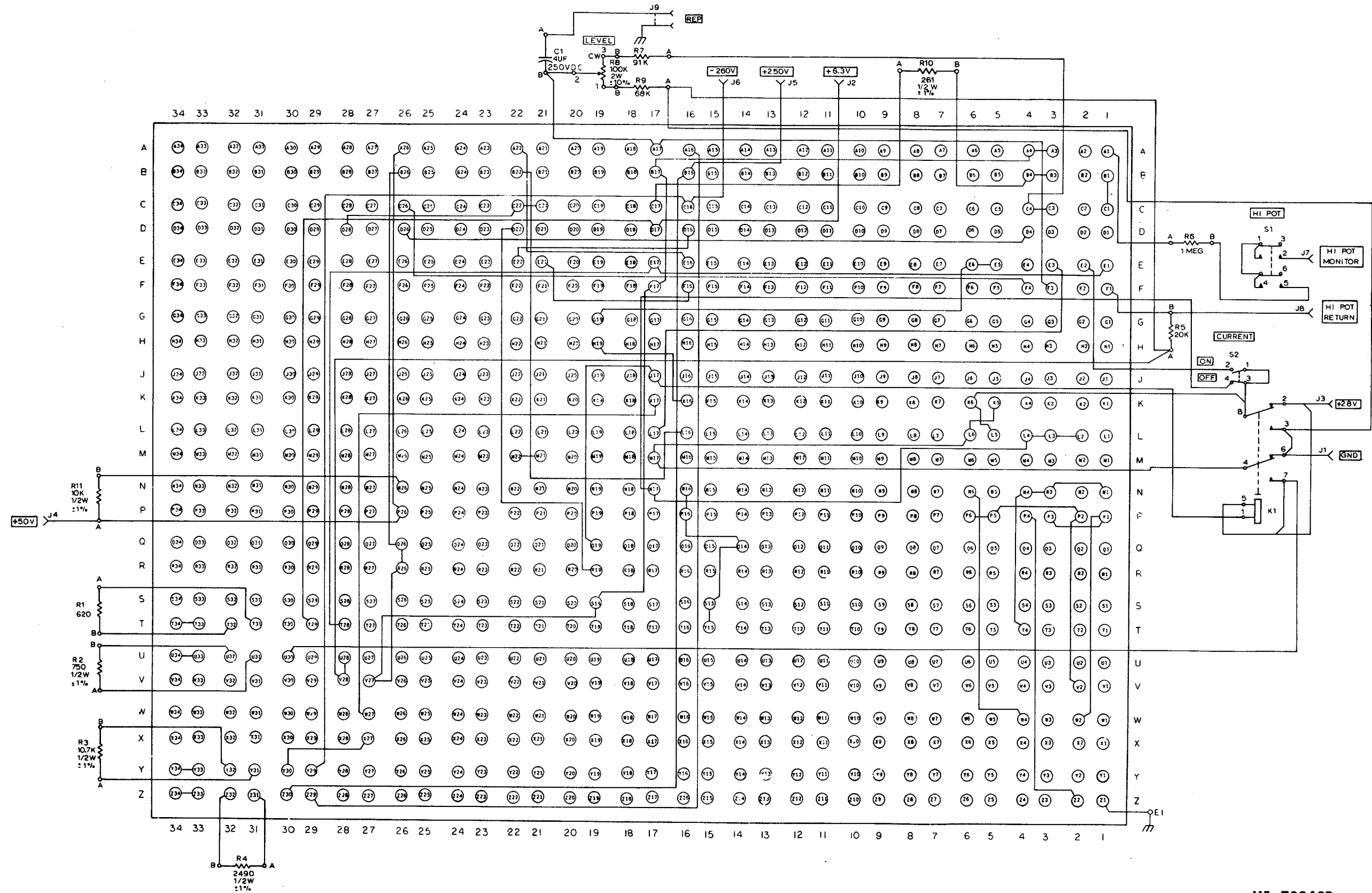
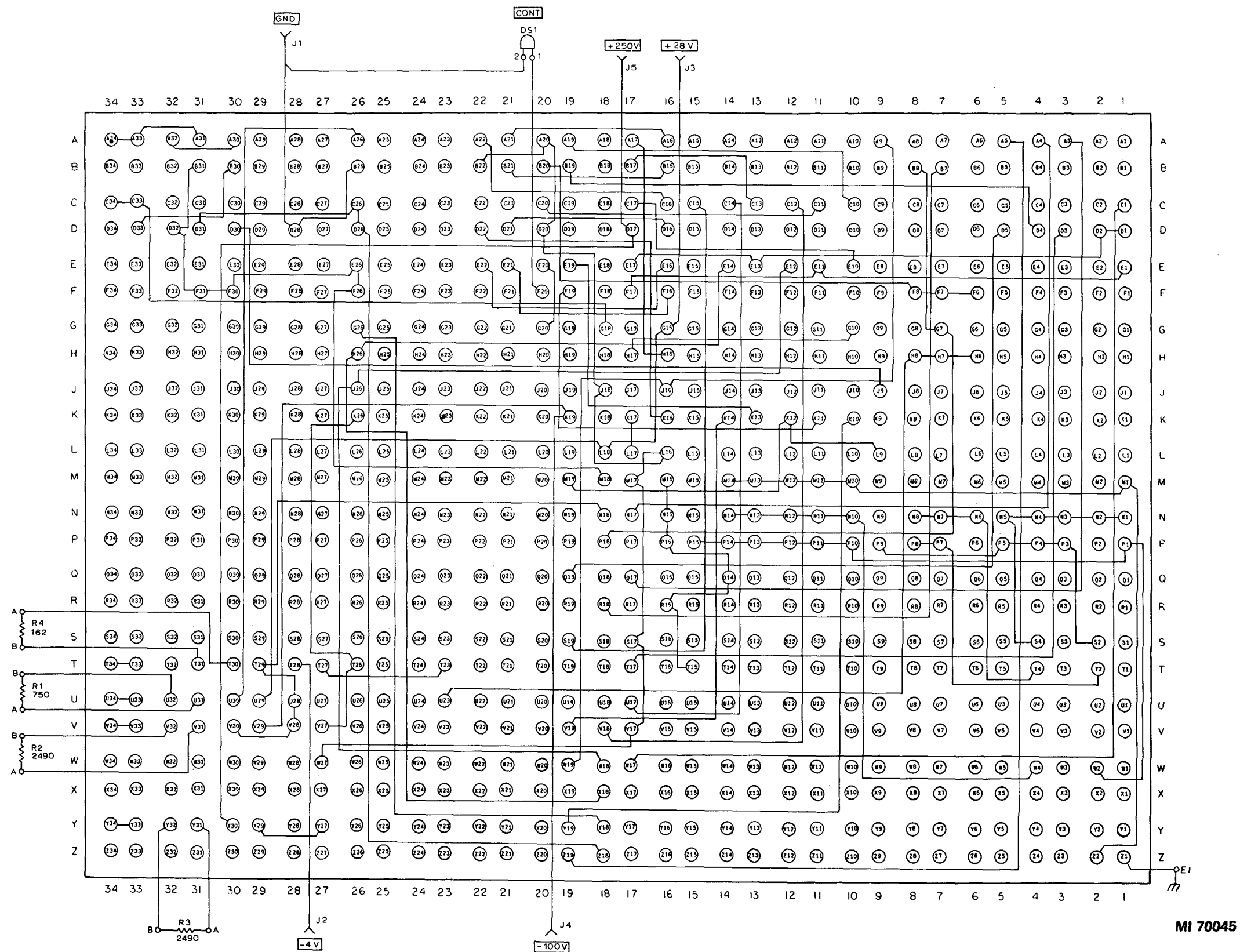

Figure 3-104 Pb HPI8-1019A 10288125 (FG 1255) - schematic.



MI 70045

Figure 3-105 Pb HPI8-1020 10675898 (FG 1657) - schematic.

WIRING TABLE	
PIN NO.	
FROM	TO
A22	F16
B2	B22
B3	F2
B3	V30
B16	B17
C17	G17
D17	F4
D22	G16
E21	L16
F17	T30
G4	H17
G17	K17
J1	T3
J4	U3
J16	K16
K1	U4
K4	W4
K16	M16
M2	W1
M3	S1
M4	U1
M16	N16
N2	V2
N3	S2
N4	W2
N16	Q12
N33	P34
Q13	K17
Q13	T15
S29	S30
T15	U15
T33	T34
U15	V29
V33	V34
Z1	GRD

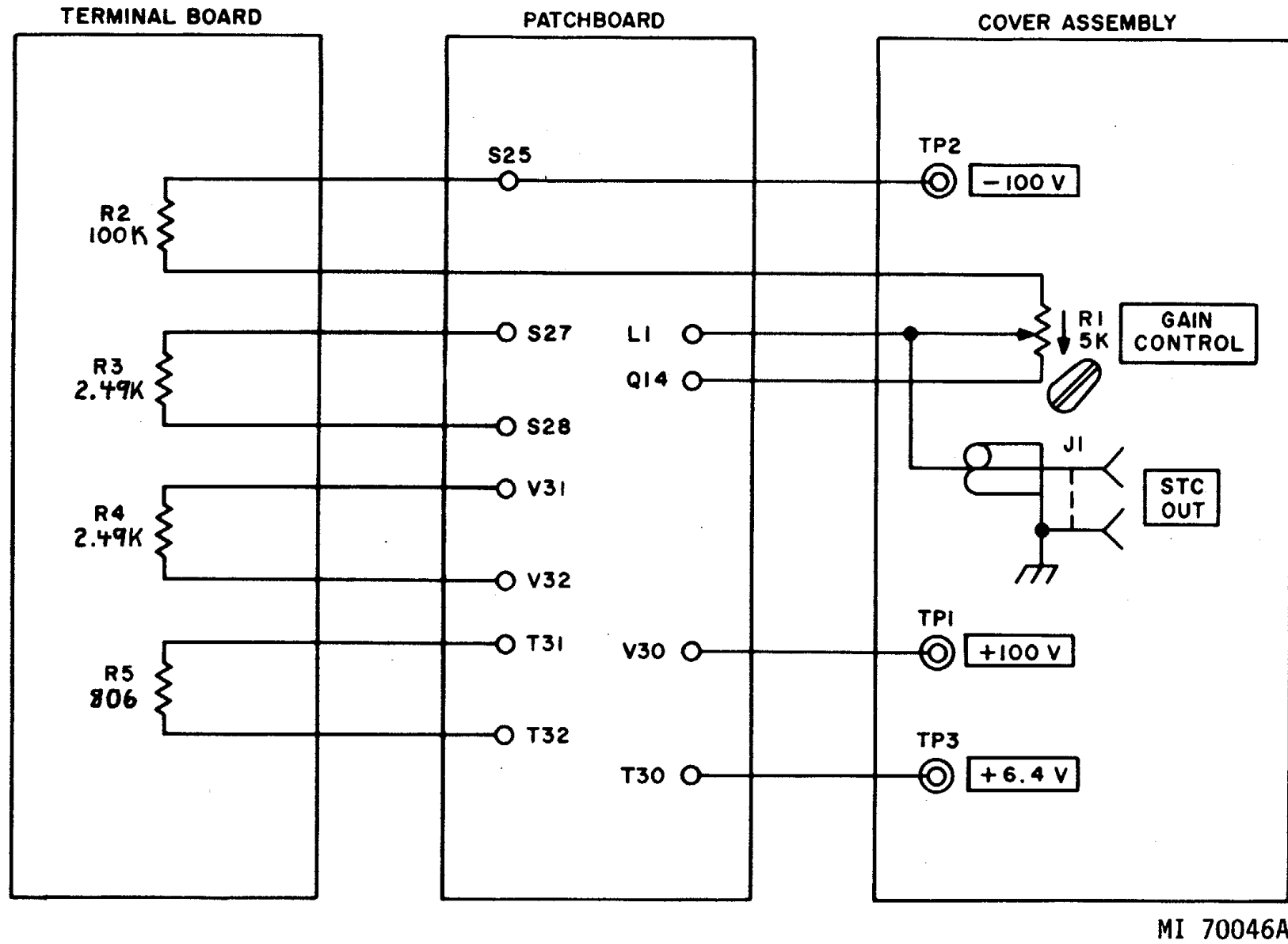

Figure 3-106 Pb HROR-501 10042753 (FG 1305) - schematic.

WIRING TABLE	
PIN NO.	
FROM	TO
A1	B1
A2	L17
A4	X17
A5	Z17
A17	D28
B1	B3
B1	V17
B16	V25
B17	E28
C17	M16
D17	Z29
D32	H31
H31	M30
K32	Q34
K33	P34
K34	N34
L17	U25
M1	M4
M2	M3
M2	V10
M4	M5
M4	W10
M16	N16
N1	U9
N3	R9
N16	P16
N17	Y30
P16	Q14
Q7	R7
Q11	T15
Q11	U11
Q17	S26
R17	V29
S25	V27
S29	S30
T15	U15
U15	W16
V25	W25
V27	V30
V30	Y29
V33	V34
W16	Y16
Y29	Z30
Y33	Y34
Z33	Z34
Z1	GRD

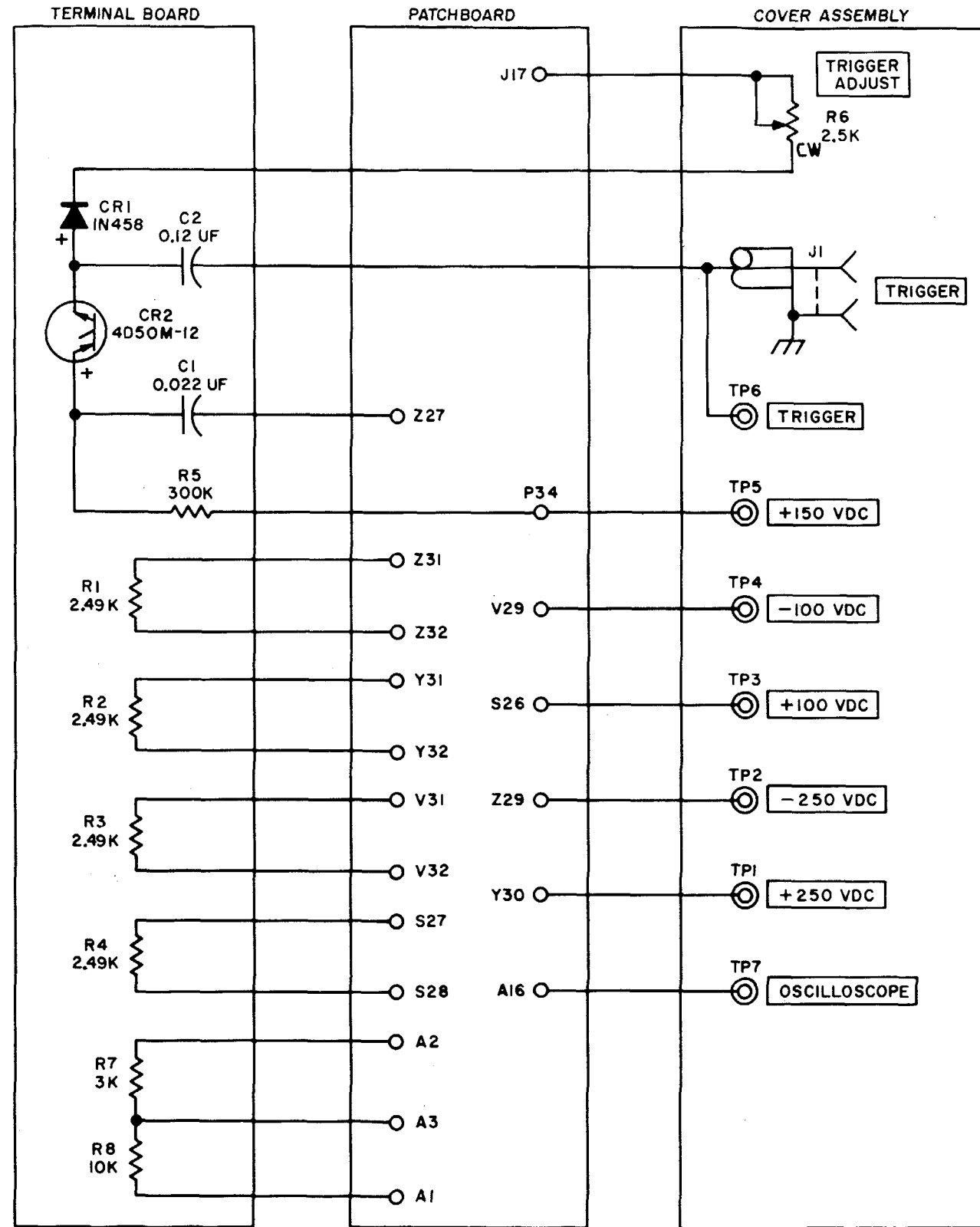

Figure 3-107 Pb HROR-502A 10103211 (FG 1310) - schematic.

MI 70047A

WIRING TABLE	
FROM	TO
A17	K5
A18	J9
A21	H16
A31	A32
A31	G14
A35	E54
B17	K6
B18	F4
B21	F16
B31	D32
C17	P18
C18	J4
D17	G6
D18	Z29
D21	G16
D27	G24
D33	J31
E2	F1
E2	S17
E16	N17
E17	H6
E28	J18
F2	F3
F3	F4
F17	J6
F24	N23
G1	L18
G5	H6
G6	H5
G13	U18
G14	G15
G17	Q13
G18	W18
G24	M18
H15	V18
J5	J6
J8	L17
J31	M30
K16	U17
K32	Q34
K33	P34
K34	N34
L1	L6
L2	L3
L3	U4
L4	T4
L5	L6
L5	S4
L6	L13
L13	L14

WIRING TABLE	
FROM	TO
L14	L15
L16	M16
L18	P23
M1	U3
M2	M13
M2	V3
M3	T3
M5	M6
M5	W3
M6	M14
M15	X3
M16	N16
N1	N3
N1	U2
N5	N4
N5	N6
N5	S2
N6	N13
N16	P16
N18	Q9
P1	P2
P1	X1
P3	P4
P3	T1
P5	P6
P5	V1
P6	P13
P16	Q8
Q6	U6
Q10	T10
Q11	T11
Q12	V12
Q14	T15
S18	Y30
S25	W27
S26	Y18
S29	S30
T15	U15
T17	U27
U15	W16
U17	U30
U27	V27
U33	U34
V28	V30
V29	Z18
V33	V34
Y27	Y29
Y33	Y34
Z33	Z34
Z1	GRD

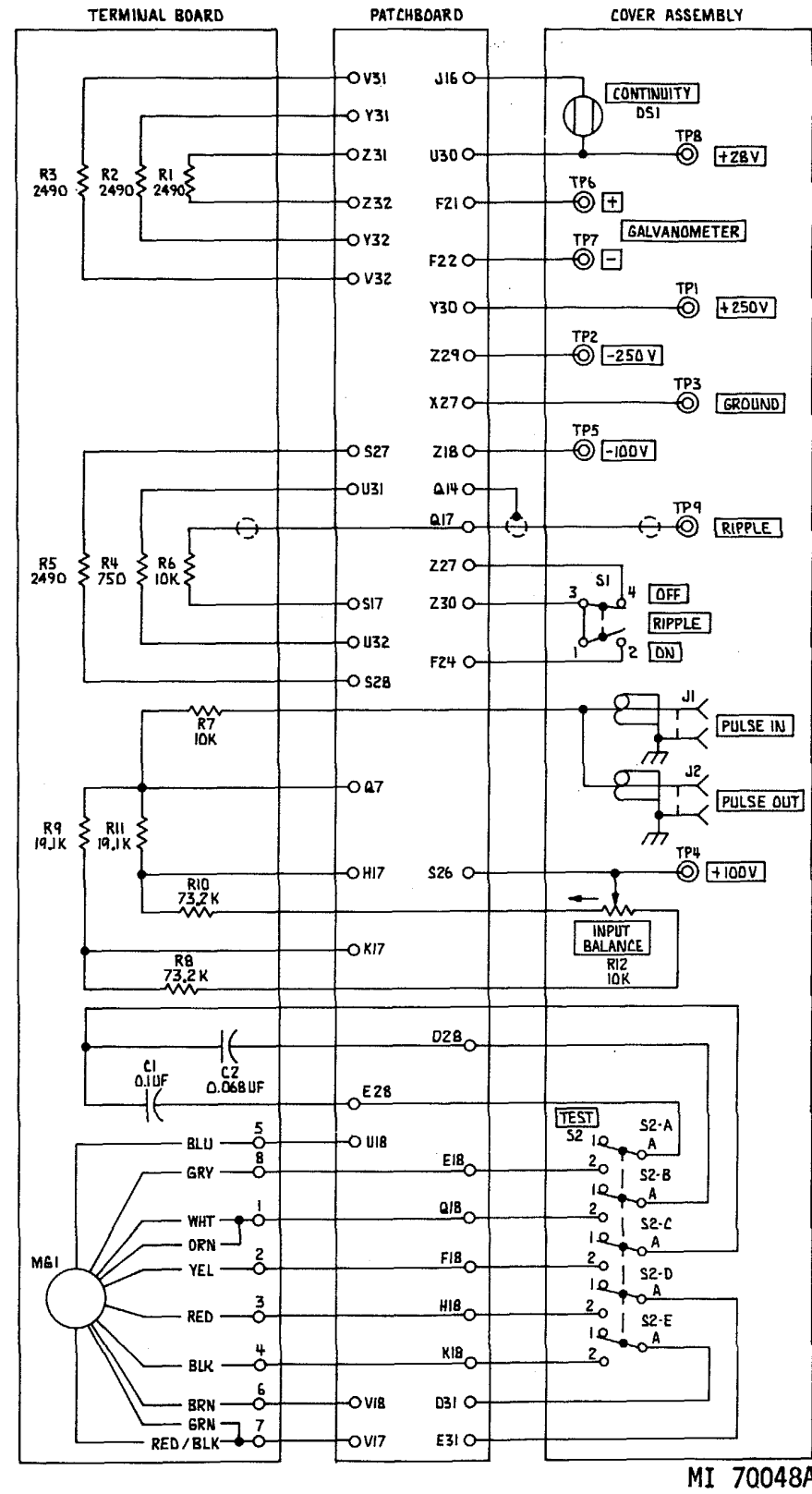
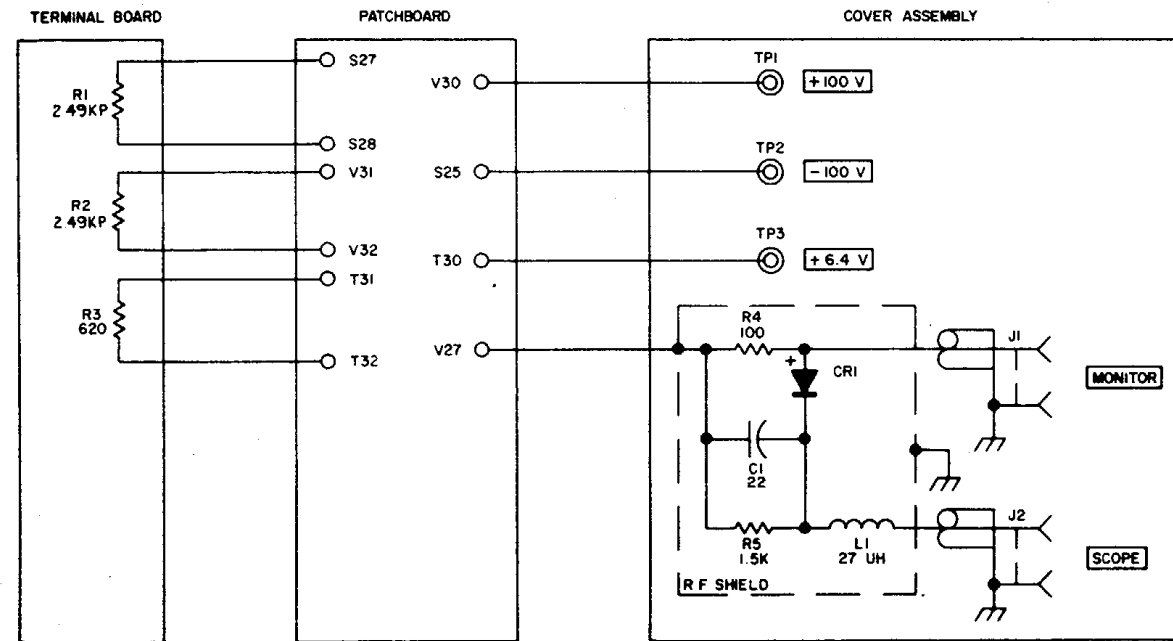

Figure 3-108. Pb HROR-503B 1011216 (FG 1315) - schematic.

WIRING TABLE	
PIN NO.	
FROM	TO
A1	B22
A2	B1
A2	A3
A3	V30
A16	B17
A22	B16
C17	H16
D1	D22
D2	E1
D2	D3
D3	S25
D16	E17
E16	E22
F17	T30
H2	T11
H3	U11
H16	J16
H31	J2
J3	L31
J16	Q3
K32	Q34
K33	N33
K34	N34
M30	T28
N33	P34
Q1	W1
Q2	V2
Q3	V3
Q4	V4
Q10	T10
Q14	T15
S26	T28
S29	S30
T15	U15
T28	V28
T33	T34
V28	V29
V33	V34
Z1	GRD



MI 70049

Figure 3-109 Pb HROR-504 10042756 (FG 1320) - schematic.

WIRING TABLE	
PIN NO.	
FROM	TO
A1	J17
A16	B21
A17	J5
B17	D16
C17	Q14
D2	E22
D3	E2
D3	D4
D4	V30
D22	E16
E17	S25
F17	T30
F21	J16
F22	H17
J31	M30
K32	Q34
K33	N33
K34	N34
M30	S26
N33	P34
Q1	T1
Q2	U2
Q3	W3
Q4	V4
Q6	R6
Q10	R10
Q14	T15
R10	V11
S26	V27
S29	S30
T15	U15
T28	V28
T33	T34
V29	W27
V33	V34
Z1	GRD

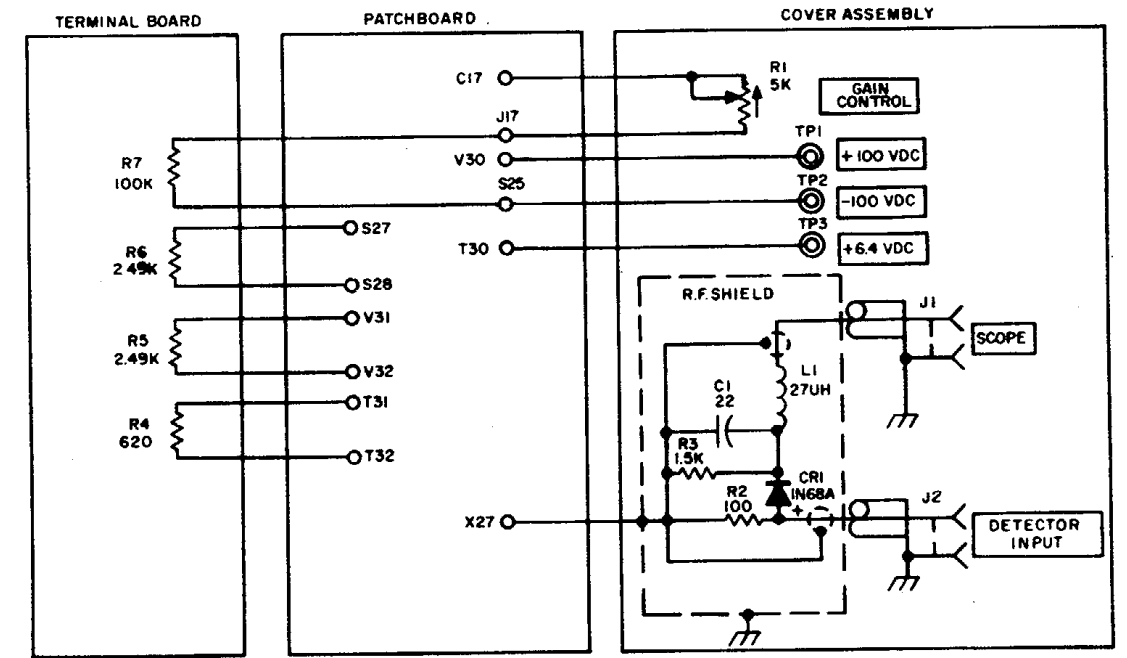

MI 70050

Figure 3-110. Pb HROR-505 10042762 (FG 1325) - schematic.

WIRING TABLE		WIRING TABLE	
FROM	TO	FROM	TO
A1	A22	G5	H5
A2	B2	G6	H6
A3	B3	G16	Z30
A4	B4	G17	H16
A5	B5	H16	L17
A6	B6	H31	L5
A16	V30	J5	M6
A17	K7	J7	J8
B1	B22	J17	K8
B16	B17	J31	L4
B21	M16	K5	K17
C1	V2	K5	M6
C5	T2	K32	Q34
C16	D16	K33	H33
C16	C17	K34	H34
C17	H17	L2	L3
D1	W1	L3	L4
D6	V1	L5	L6
D16	E16	L16	P16
D17	J5	M30	T28
D22	G1	M33	P34
E1	S3	P2	P4
E6	V3	P2	S10
E16	F16	P3	U10
E17	X9	P16	Q14
E21	M16	Q6	X6
E22	H1	Q11	T11
F1	V4	Q14	T15
F6	T4	T15	U15
F16	L16	T28	V28
F17	J9	T33	T34
F17	T30	U15	V15
F21	J16	V28	V29
F22	K16	V33	V34
G2	H2	Z27	Z29
G3	H3	Z33	Z34
G4	H4	Z1	GRD

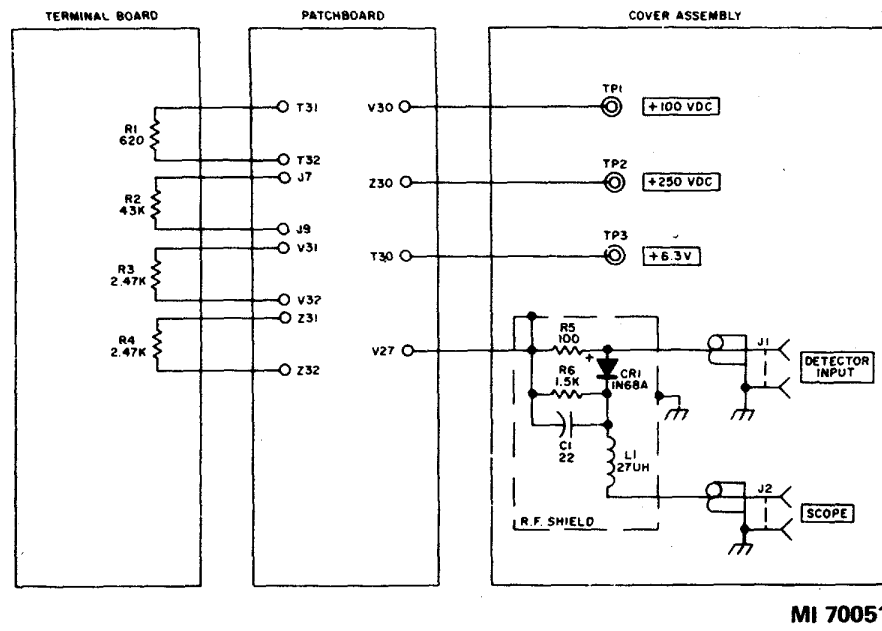

Figure 3-111 Pb HROR-506A 10103527 (FG 1330) - schematic.

WIRING TABLE	
FROM	TO
A16	A17
A17	C17
A26	C28
B17	V30
B21	K17
B26	D28
C17	G26
D2	D17
D16	Q14
E17	S25
F17	F26
G26	H26
H17	J26
H26	S26
Q2	T2
Q14	T15
R16	T15
S26	V28
S29	S30
T2	X1
V28	V29
V33	V34
Z27	Z29
Z33	Z34
Z1	GRD

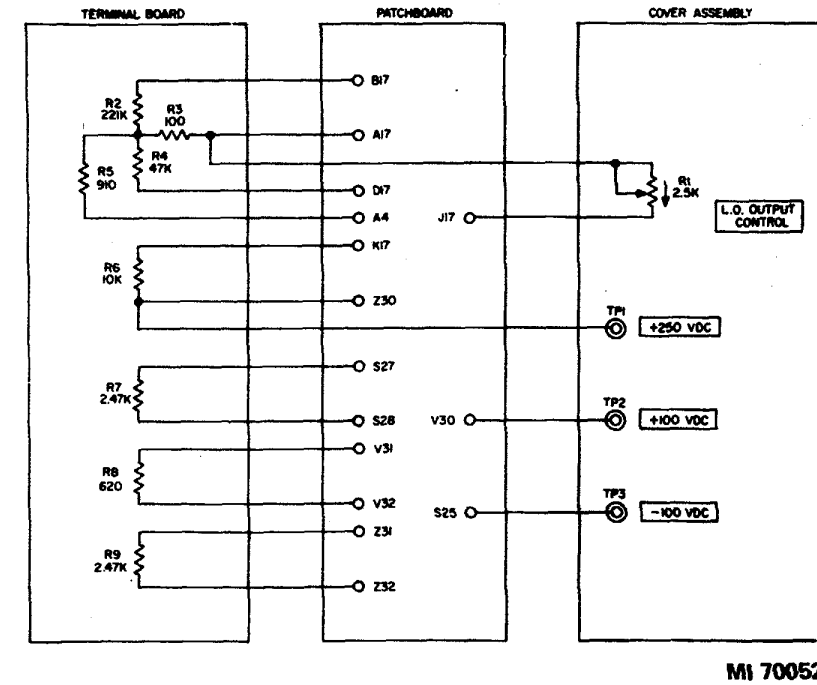

Figure 3-112. Pb HROR-507 10042764 (FG 1335) - schematic.

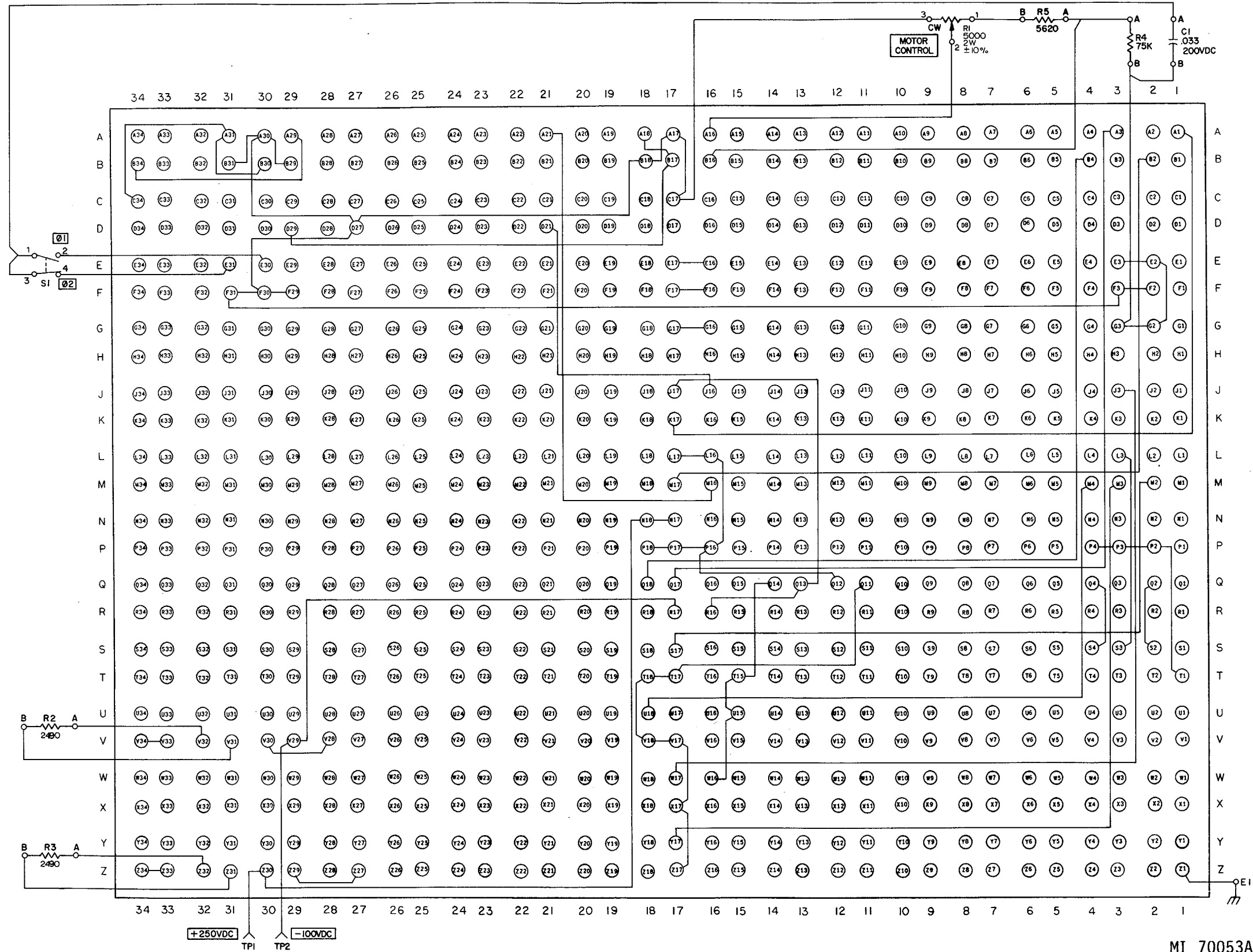
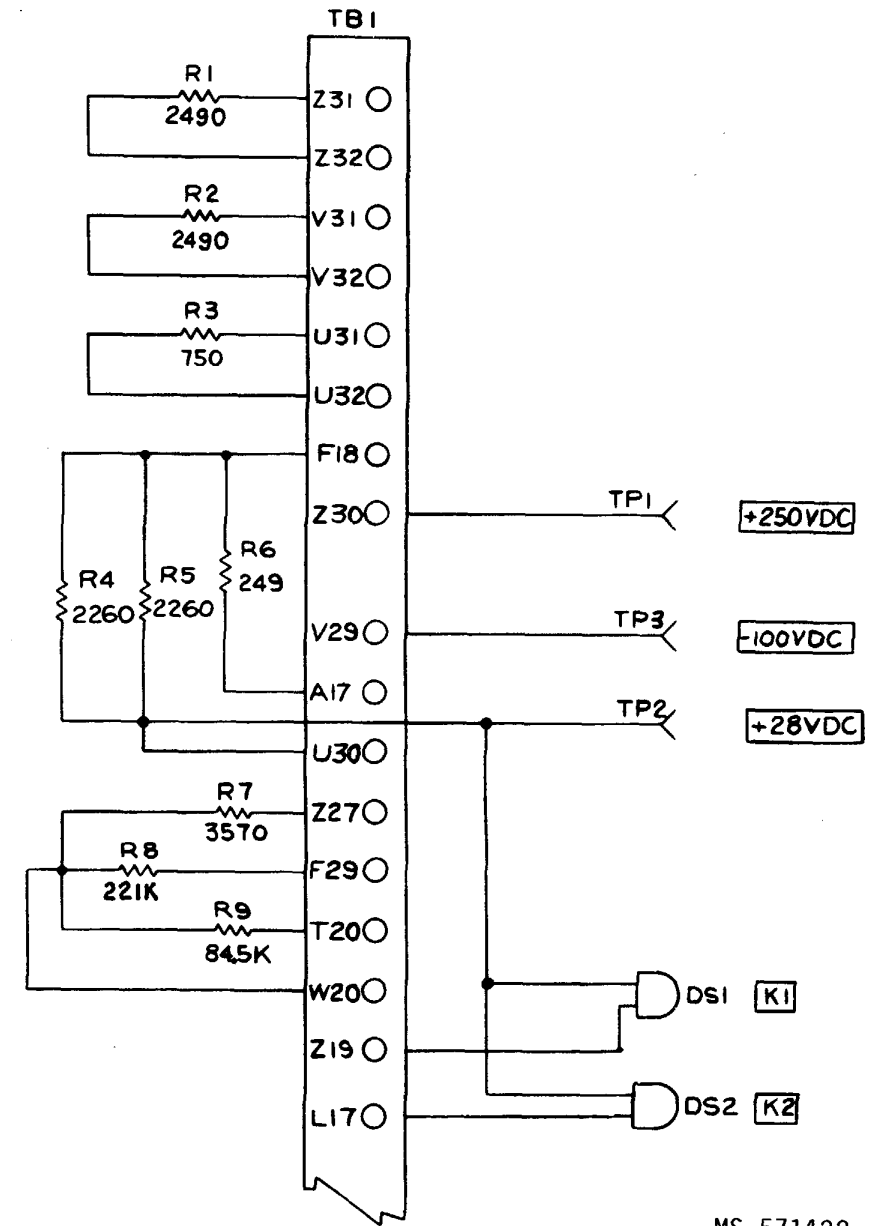
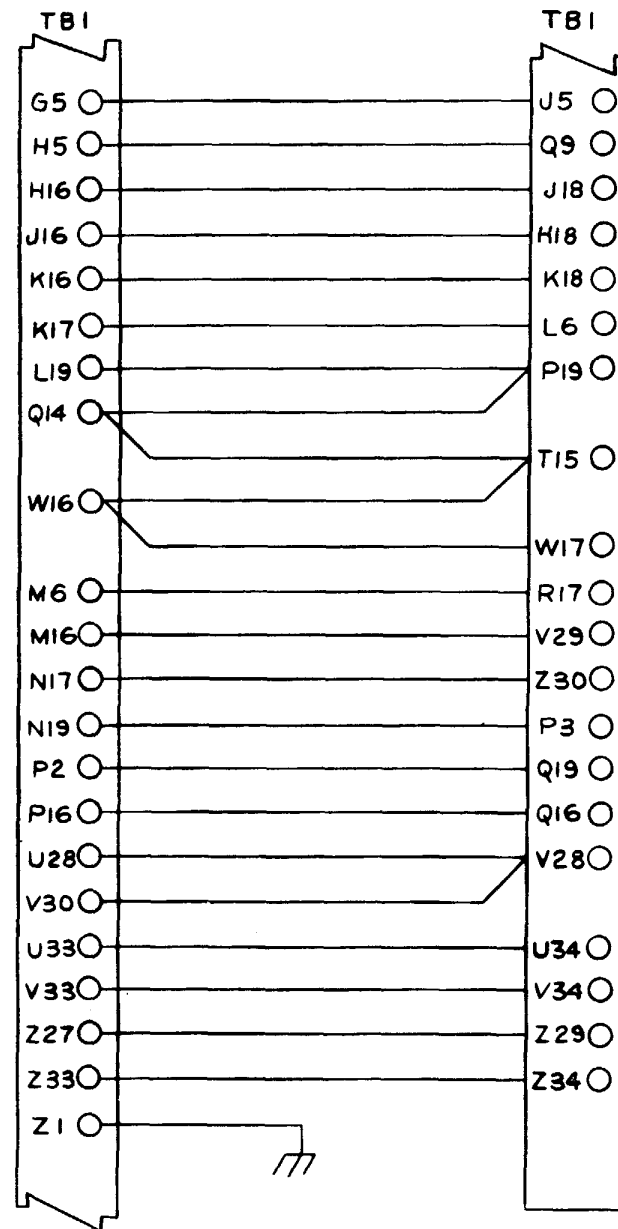
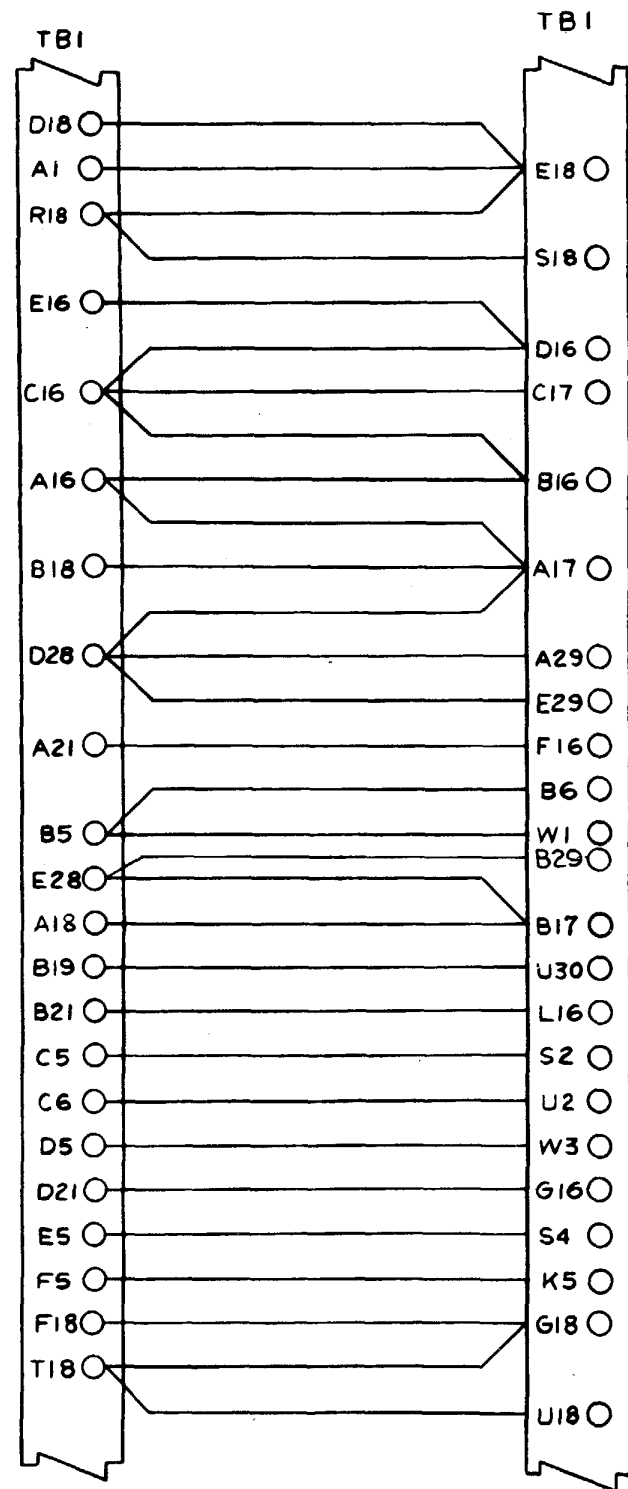

Figure 3-113. Pb HROR-508A 10675080 (FG 1340) - schematic.

3-167(3-168 blank)

MI 70053A



MS 571422

Figure 3-114. Pb HROR-509B 10104940 (FG 1345) - schematic.

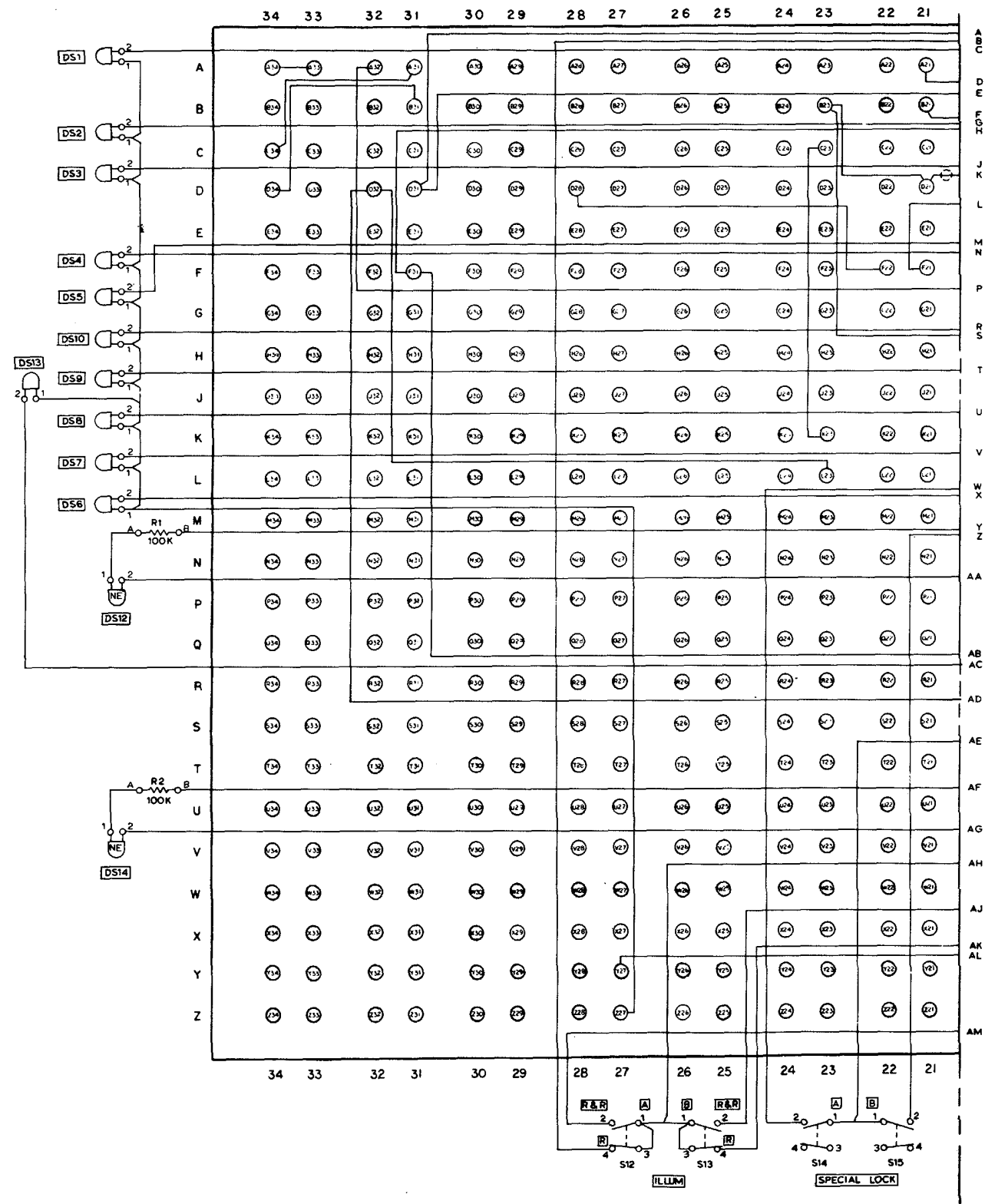

MI 70055

Figure 3-115. Pb HROR-510B 10674587 (FG 1350) - schematic (sheet 1 of 2)

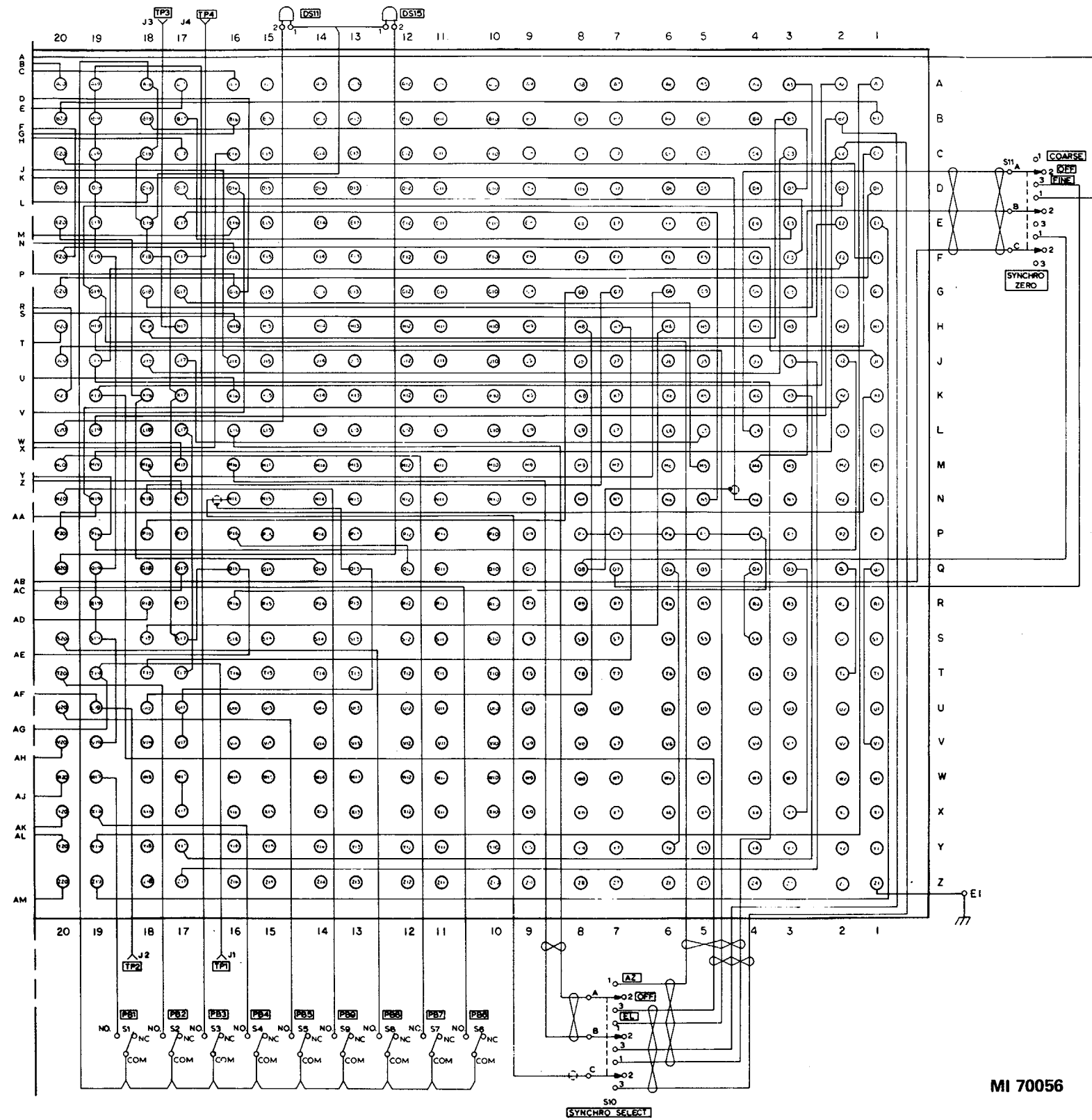

Figure 3-115. Pb HROR-510B 106774587 (FG 1350) - schematic (sheet 2 of 2).

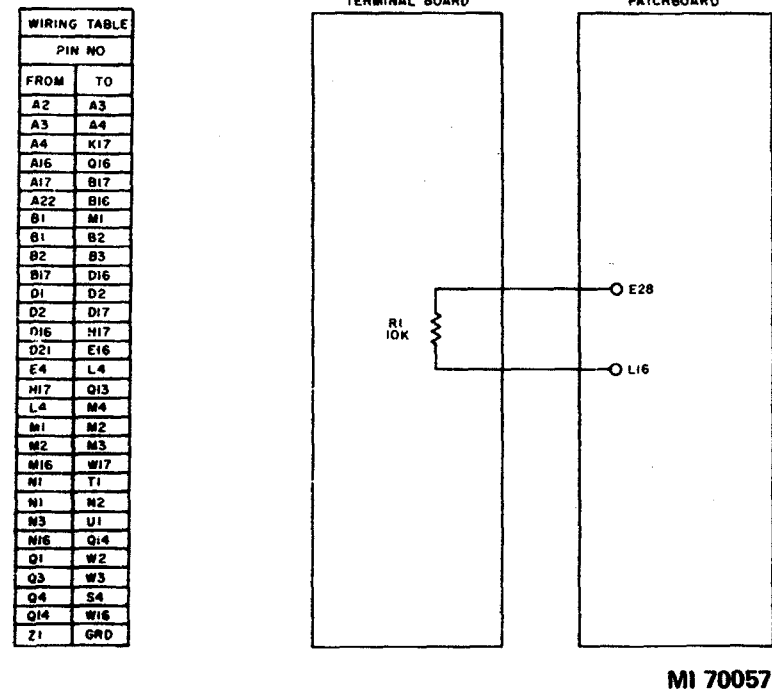

Figure 3-116. Pb HROR-511 10042768 (FG 1355) - schematic.

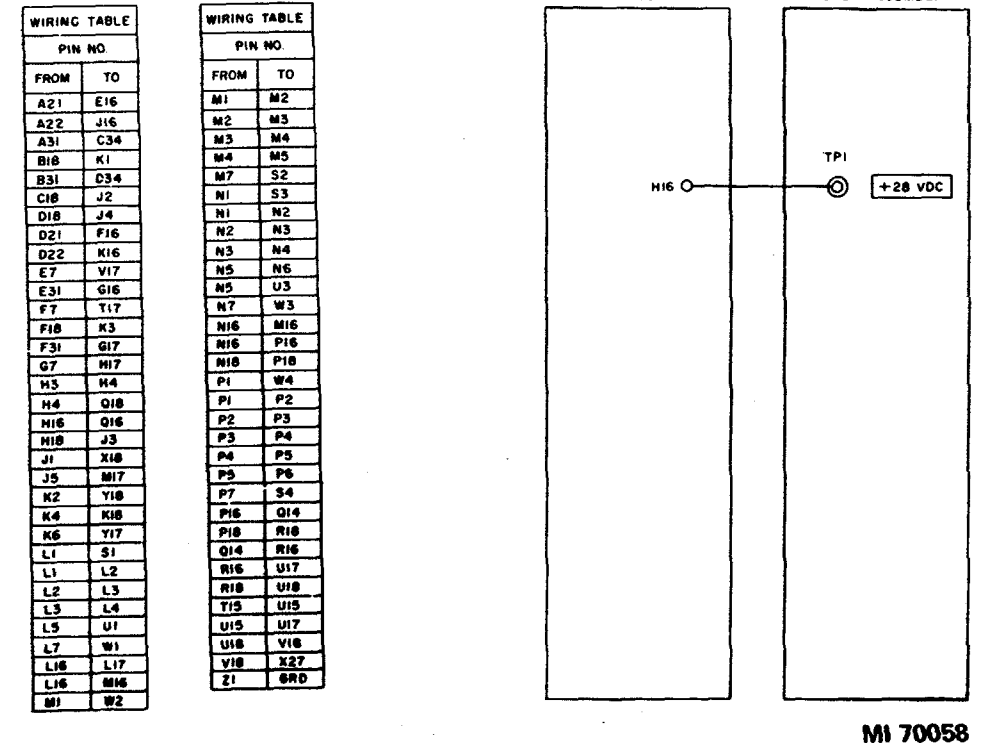
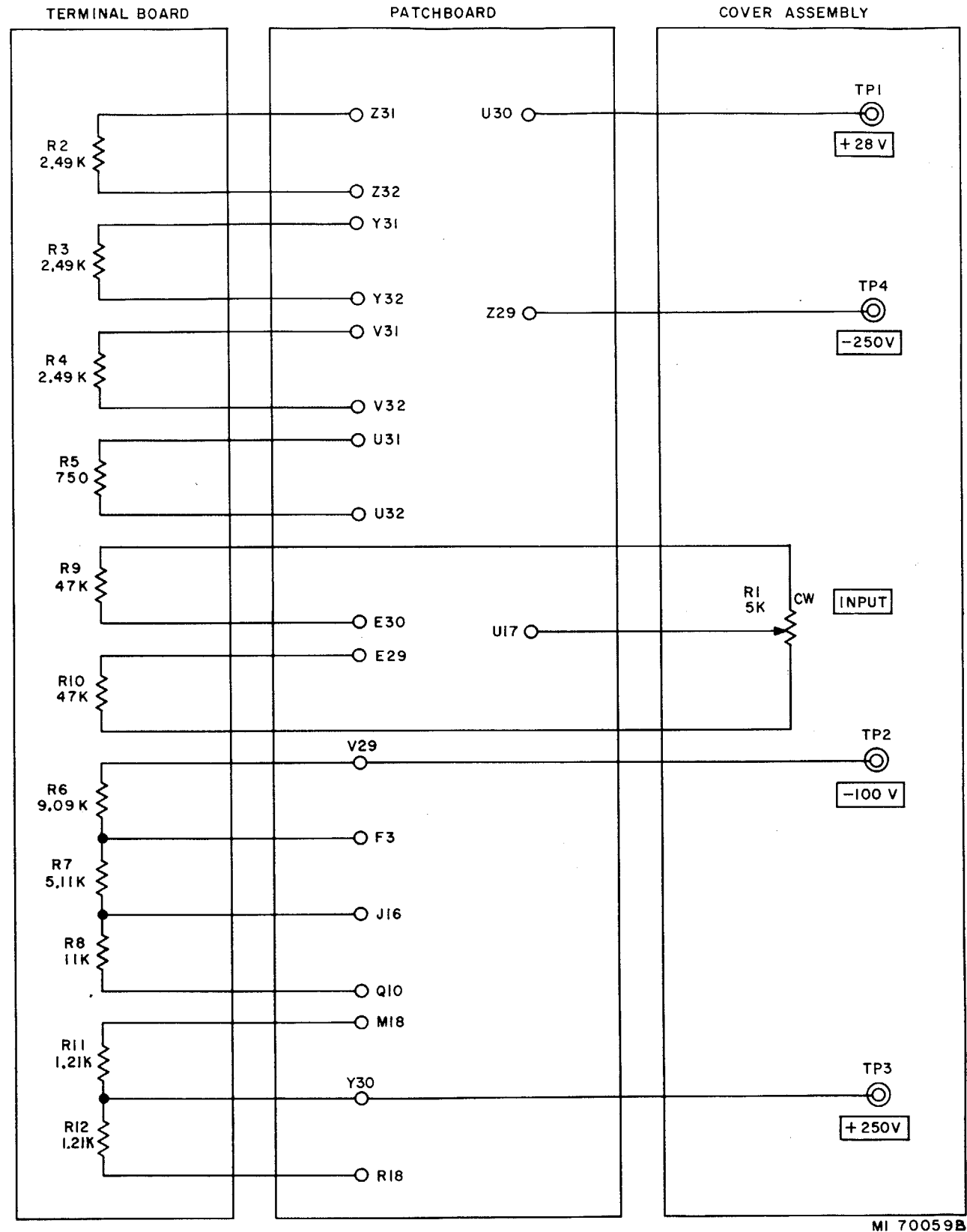

Figure 3-117. Pb HROR-512 10042769 (FG 1360) - schematic.

WIRING TABLE	
PIN NO.	
FROM	TO
A1	E17
A16	A22
A17	A18
A18	E28
A21	B16
A29	E28
A29	B30
A30	B29
B2	W17
B3	L17
B17	C17
B17	B18
B21	C16
B29	D28
C4	C5
C5	C6
C6	M18
C17	F17
D1	S17
D16	D22
D17	Z29
D21	H16
D28	F29
E4	E5
E5	E6
E6	R18
E16	E21
F16	J17
F17	L16
F29	F30
G3	Q6
G16	K17
G17	U30
H2	Y17
J5	V18
J6	Y18
K5	U18
K6	Z18
K16	L16
L1	W4

WIRING TABLE	
PIN NO.	
FROM	TO
L2	S4
L4	L5
L5	L6
L5	T4
L16	M16
M1	M2
M2	S3
M4	M5
M5	M6
M5	X3
M16	N16
N1	W2
N2	N3
N2	S2
N4	T2
N4	N5
N5	N6
N16	P16
P1	S1
P1	P2
P3	V1
P4	P5
P5	P6
P5	X1
P16	Q14
P17	Y30
P17	P18
Q14	T15
R17	V29
T15	W16
T15	T17
U28	V28
U33	U34
V17	T17
V28	V30
V33	V34
Y27	Y29
Y27	Z30
Y33	Y34
Z33	Z34
Z1	GRD



MI 70059B

Figure 3-118. Pb HROR-515 10042772 (FG 1365) - schematic.
3-173

WIRING TABLE	
PIN NO.	
FROM	TO
A17	F21
B17	V30
C17	G17
E17	S25
F17	T30
F22	G17
G17	N16
H2	J17
H3	K17
H16	U30
K32	Q34
K33	N33
K34	N34
L31	R30
M1	M3
M3	V15
N1	R10
N1	N2
N3	U10
N16	P16

WIRING TABLE	
PIN NO.	
FROM	TO
N33	P34
P1	P2
P2	T11
P3	U11
P16	Q14
Q1	S1
Q6	R6
Q14	T15
R30	S26
S1	T2
S26	T28
S29	S30
T15	U15
T28	U28
T33	T34
U28	V28
U33	U34
V28	V29
V33	V34
Z1	GRD

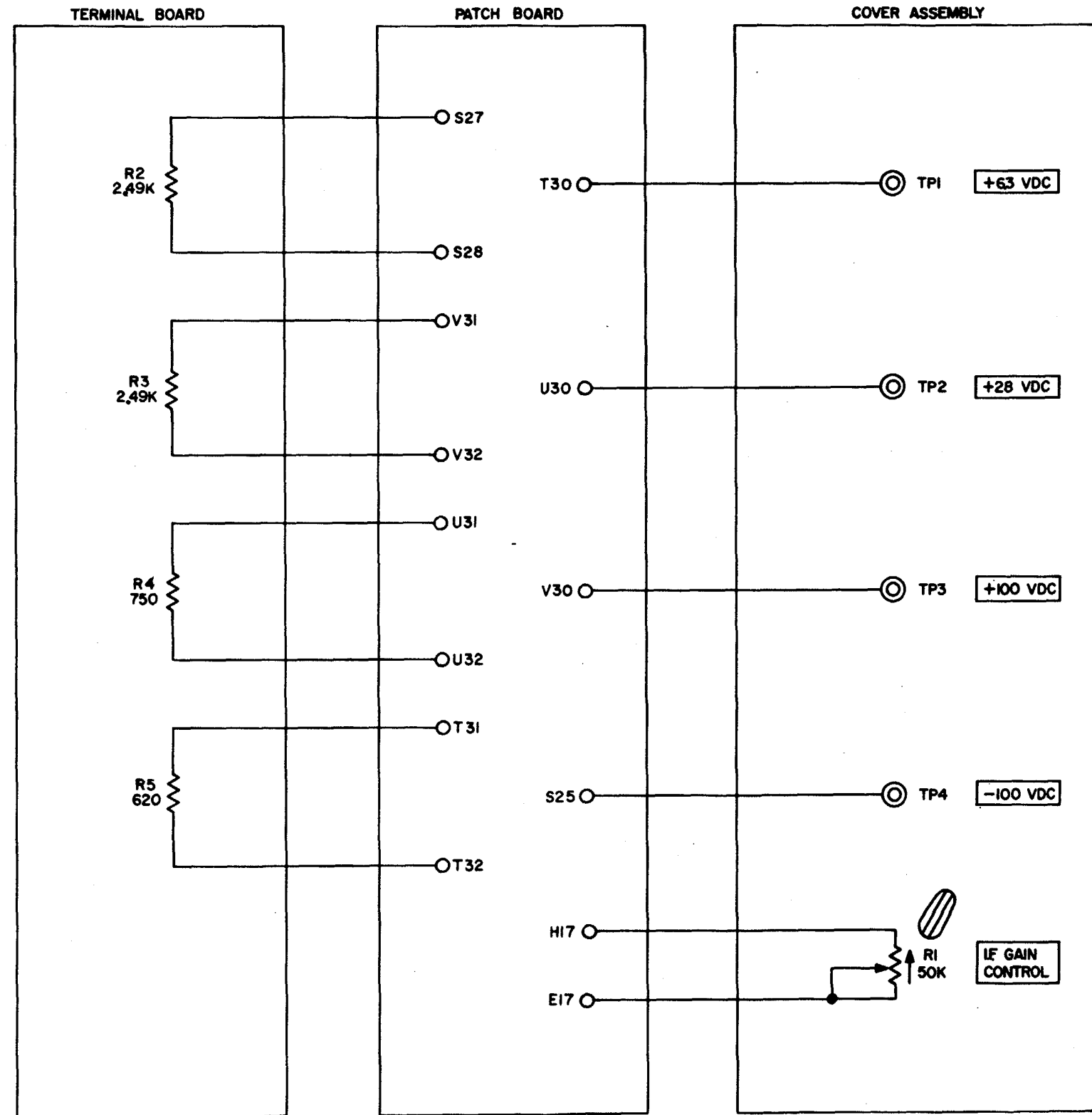

MI 70060A

Figure 3-119. Pb HROR-516A 10103660 (FG 1350) - schematic.

WIRING TABLE	
PIN NO.	
FROM	TO
A1	L17
A2	J17
A17	C17
B17	E28
C17	D27
D17	Y29
E17	E28
F17	F28
G17	G28
H31	P2
K32	L32
K33	L33
K34	L34
L32	Q34
L32	P34
L34	N34
M29	M31
M29	R30
M29	S26
M31	P1
N17	Z30
Q14	T15
Q17	V30
R17	S25
S26	V28
S29	S30
T15	U15
U15	W16
V28	V29
V33	V34
Y27	Y30
Y33	Y34
Z27	Z29
Z33	Z34
Z1	GRD

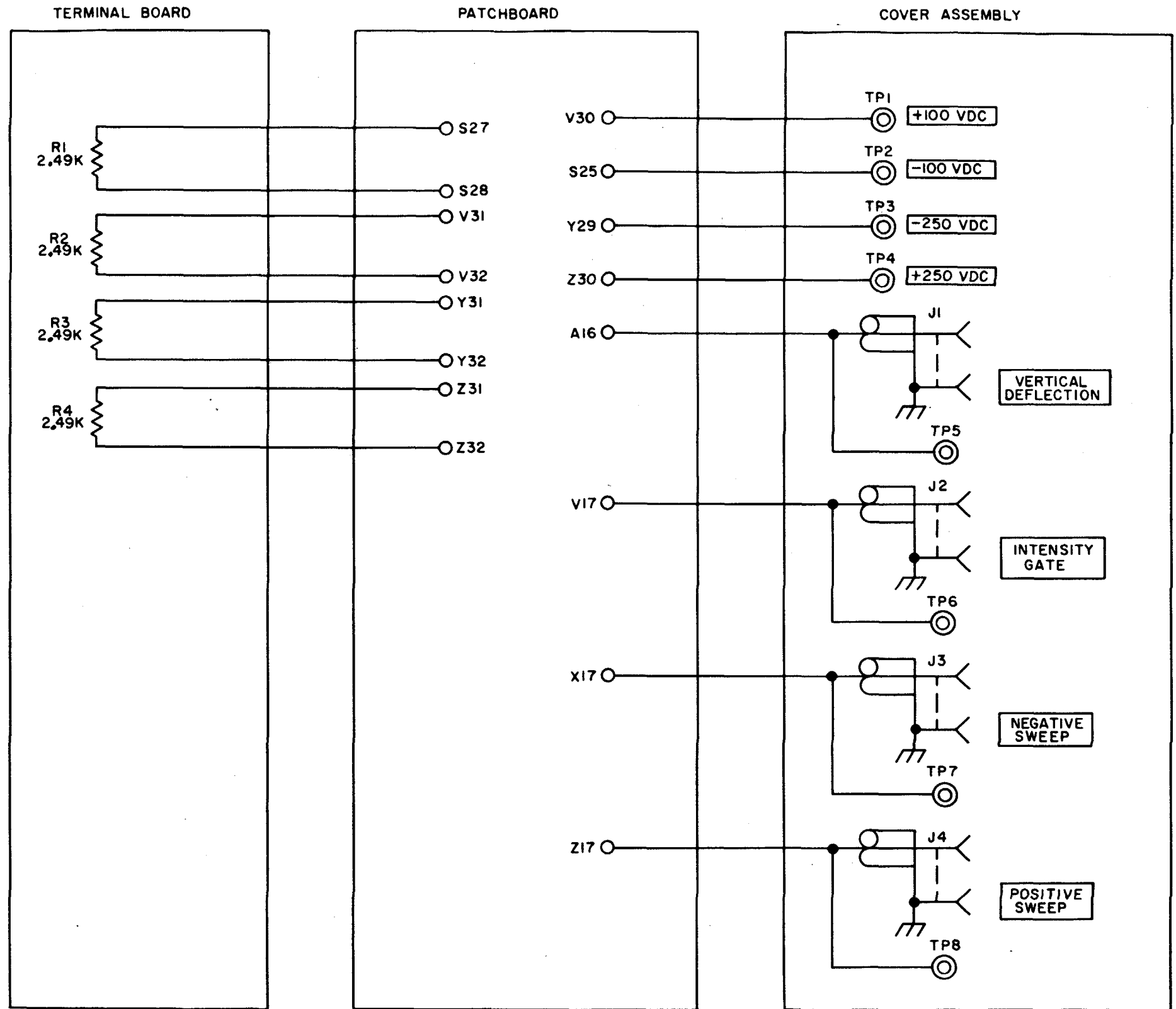
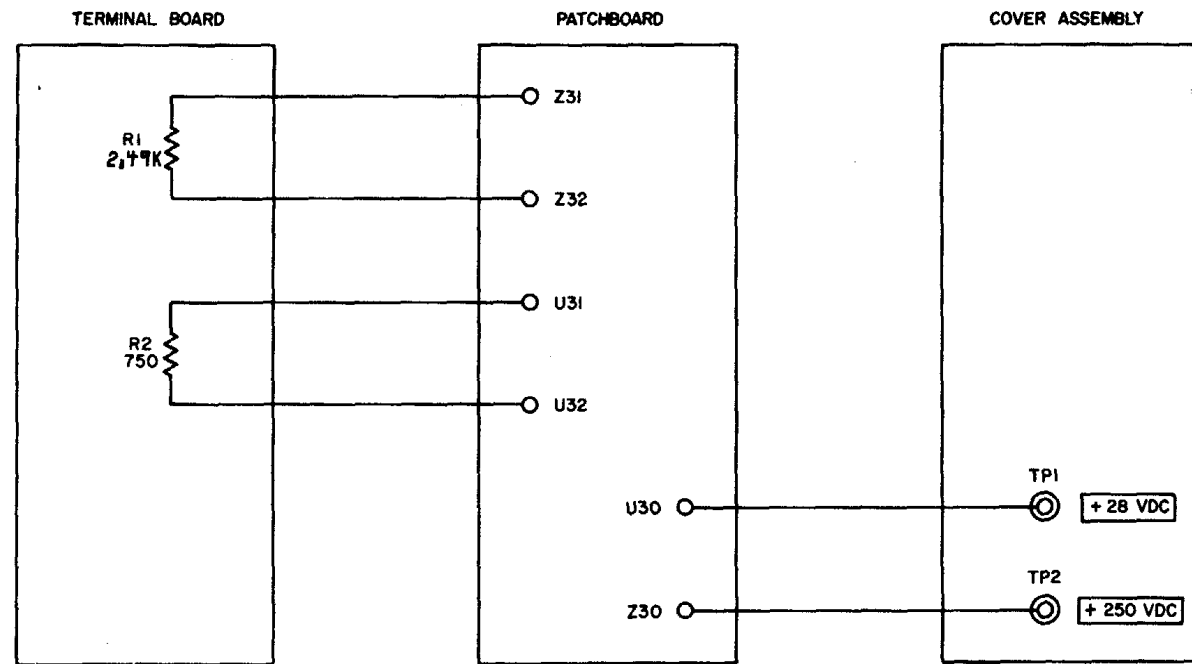

Figure 3-120. Pb HROR-517A 10103250 (FG 1375) - schematic.
3-175

MI 70061A

WIRING TABLE	
PIN NO.	
FROM	TO
A17	P2
A26	C28
B17	C26
B26	D28
C17	E26
D17	F17
E17	Z30
F17	M16
H31	M30
K32	Q34
K33	P34
K34	N34
M1	M2
M1	X10
M2	M3
M3	M4
M5	W10
M16	N16
M30	U28
N1	N2
N1	U11
N3	S11
N3	N4
N4	N5
N16	Q14
P16	U30
Q7	X7
Q9	X9
Q14	T15
R16	T15
T15	U15
U28	V28
U33	U34
Z27	Z29
Z33	Z34
Z1	GRD



MI 70062A

WIRING TABLE	
PIN NO.	
FROM	TO
A1	A2
A1	E17
A3	N17
A4	Y17
A13	V19
A15	F19
A16	M21
A17	A19
A19	E25
A21	B16
A24	C25
A28	A29
A29	A30
B2	B3
B2	C2
B3	B4
B13	C13
B17	B19
B18	D17
B18	B20
B20	D29
B24	F24
B29	B30
B29	D28
C2	C3
C2	F17
C3	C4
C4	C13
C13	C14
C13	L19
C16	L18
C17	D18
C17	X17
C18	C20
C19	D20
C20	F29
D14	Q16
D16	G24
D17	D19
D17	H18
D18	D20
D30	Q19
E19	X20
F30	S19
H18	H20
H18	J18
H20	J20

WIRING TABLE	
PIN NO.	
FROM	TO
J17	K18
J18	K18
J18	M17
J20	K20
K17	Q19
K20	N19
L17	S19
L18	L20
M17	T17
N2	N3
N2	N13
N2	U1
N3	N4
N16	P16
P2	P3
P2	P13
P2	S2
P3	P4
P16	Q14
Q14	R16
Q19	T19
S17	T19
S19	U19
T17	W19
U19	V27
V28	W19
Z1	GRD

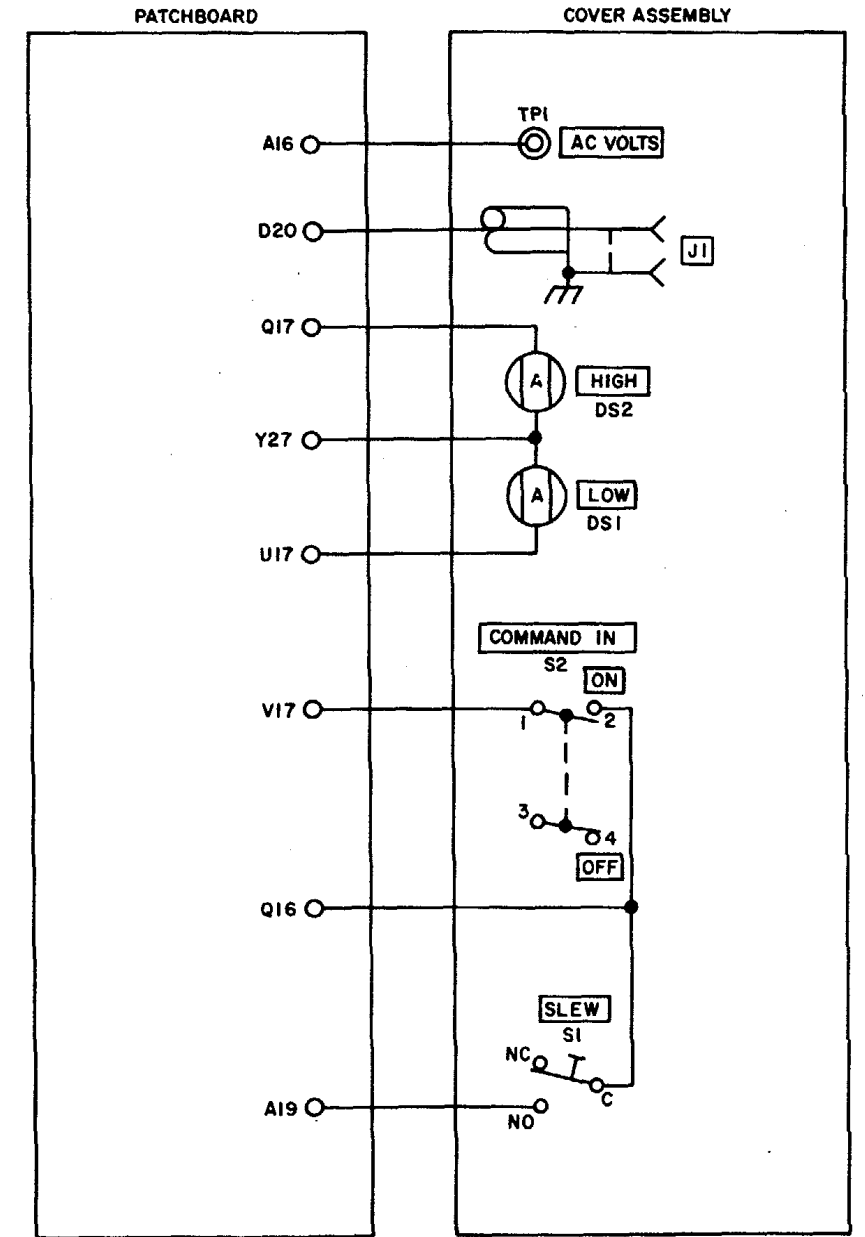

MI 70063

Figure 3-121. Pb HROR-518 10042784 (FG 1380) - schematic.

Figure 3-122. Pb HT-501B101783893 (FG 1385) - schematic.

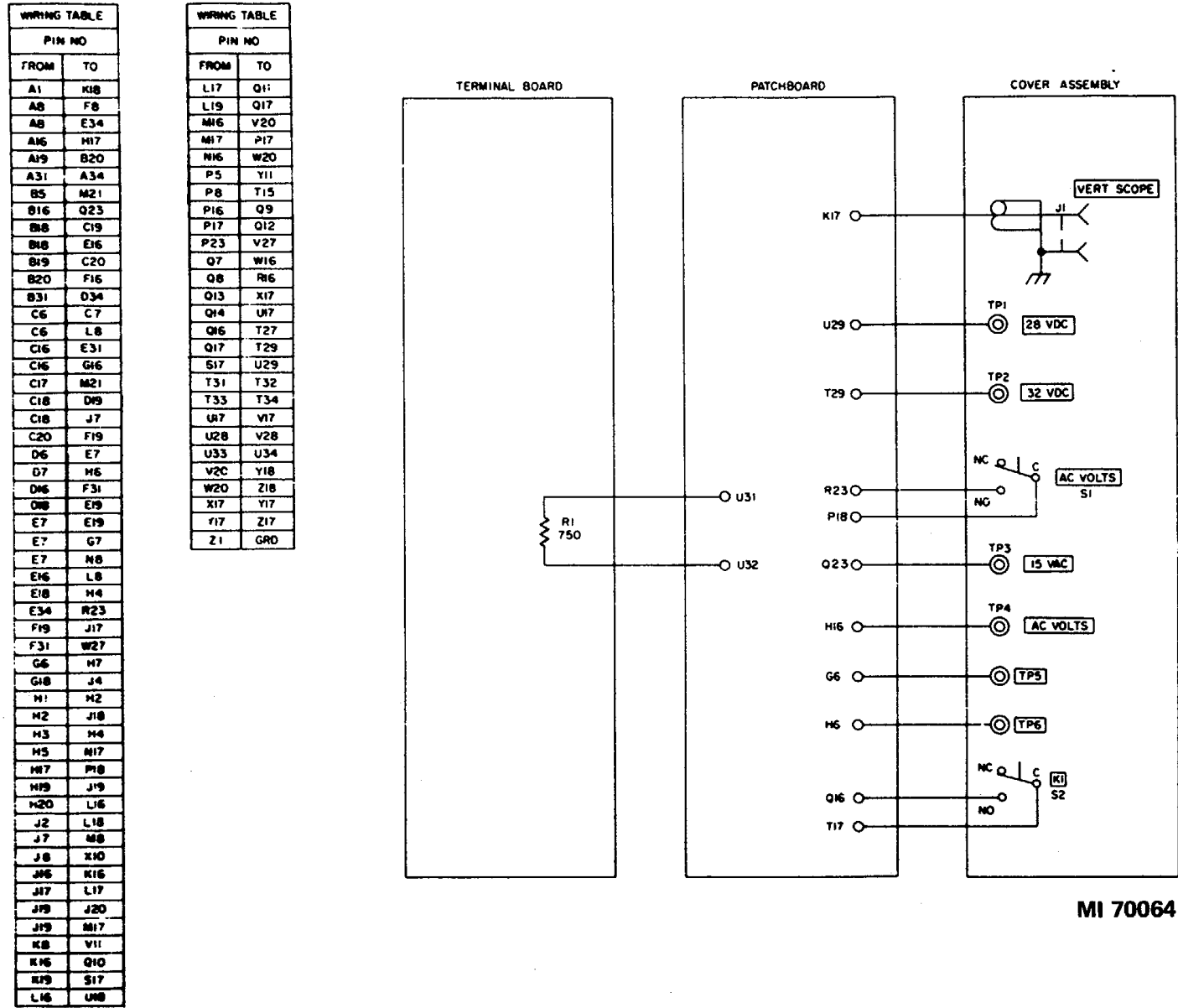

Figure 3-123. Pb HT-505A 10112739 (FG 1395) - schematic.

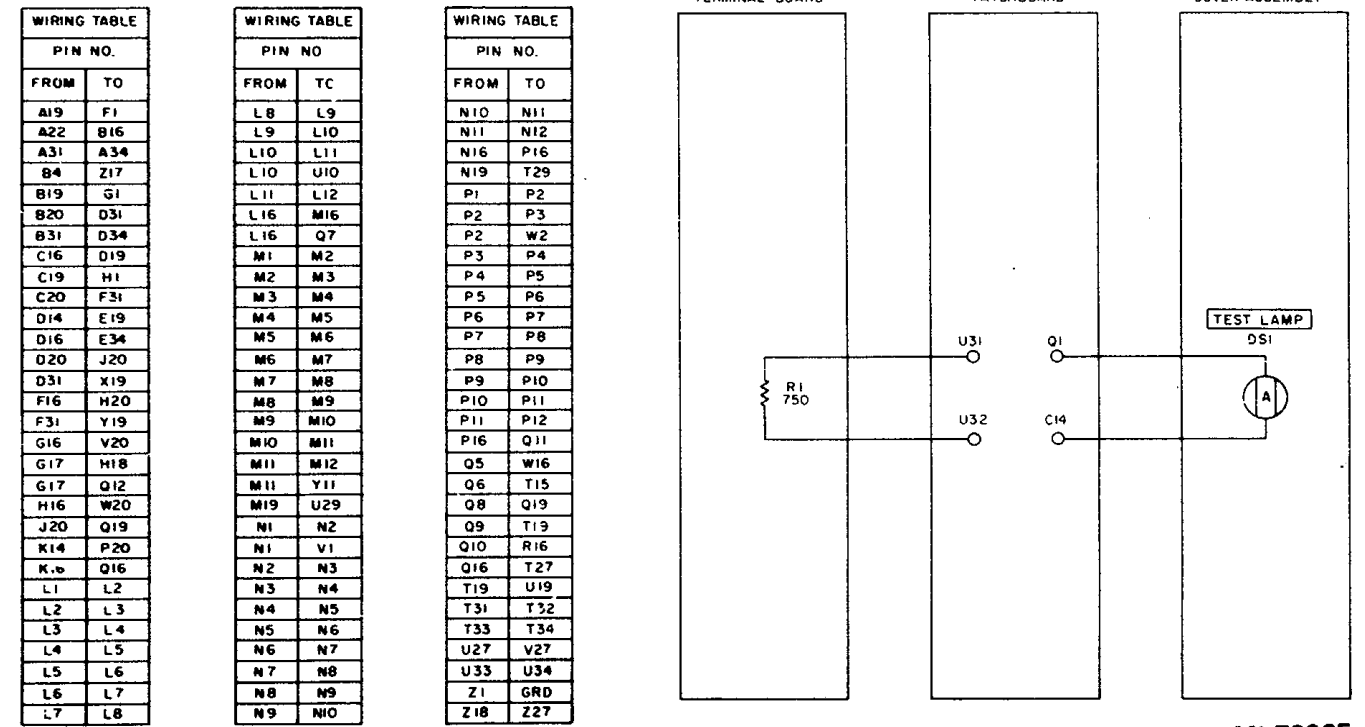
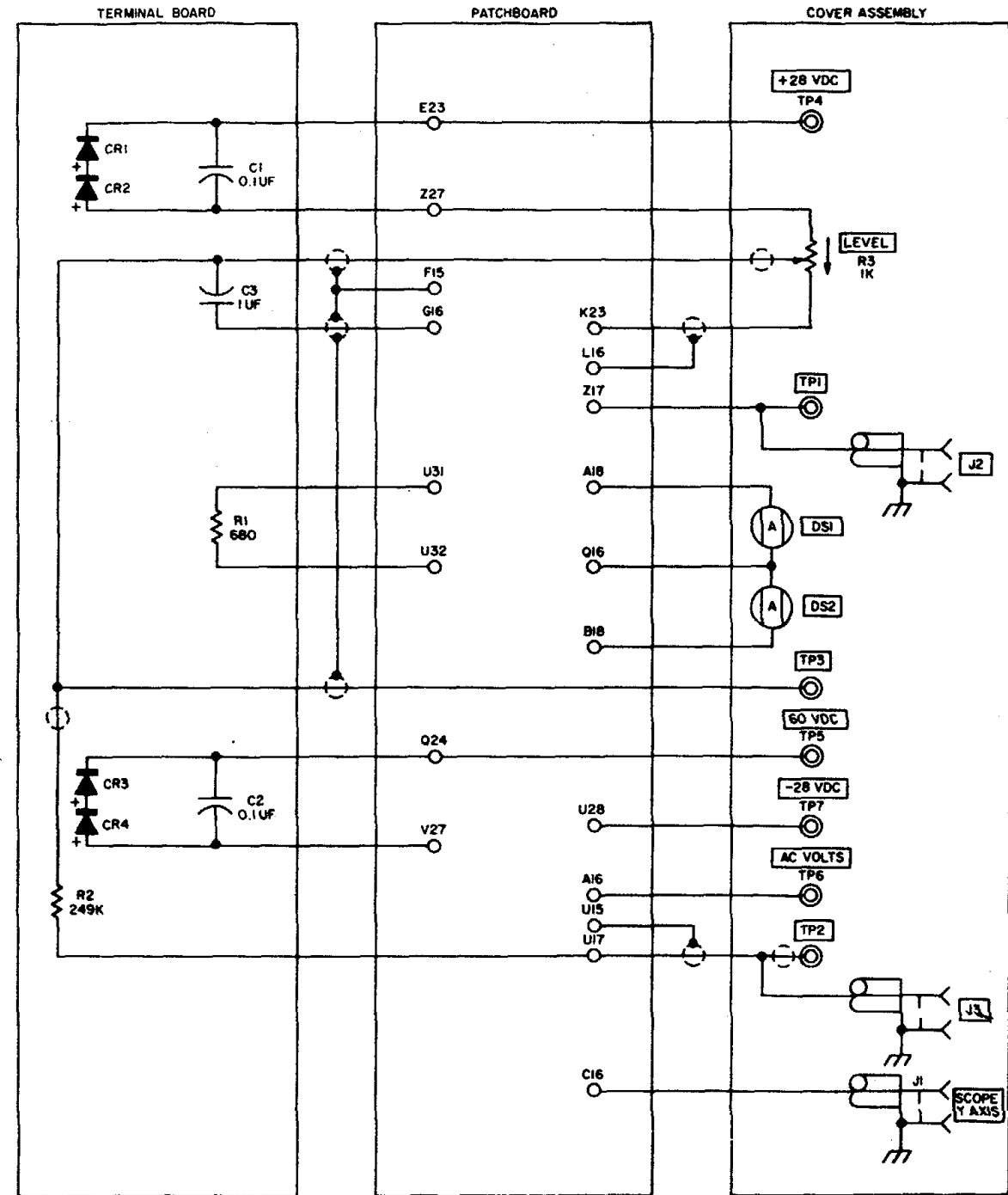

Figure 3-124. Pb HT-506 10107353 (FG 1400) - schematic.

WIRING TABLE	
FROM	TO
A14	F19
A15	T19
A19	E14
A28	A29
B4	B5
B4	L18
B16	G1
B16	U17
B19	J20
B20	D19
B20	D29
B21	H6
B29	D28
C15	U19
C18	E18
C19	F14
C20	E19
C20	F29
D15	E15
D16	M21
D21	E16
D21	L20
D23	V30
D29	K19
E15	L19
E17	E23
E17	H17
E18	K18
E19	J19
E34	J23
F15	N16
F16	K20
F17	Q24
G1	Q8
G23	H2
H1	H2
H4	H5
H4	W25
H6	H8
H16	Z17
H17	M17
H19	J20
H23	X24
J4	U7
J5	T7
J16	Q9
J18	J23
J18	K8
J20	Q19
J30	P30
K16	Y25
K18	Q12
K23	X25
K32	Q34

WIRING TABLE	
FROM	TO
K33	P34
K34	N34
L1	L2
L2	U10
L4	L5
L4	W10
L14	L15
L15	R16
L16	M16
L17	V17
M1	M2
M2	M6
M4	W11
M5	M6
M6	V11
M8	X13
M15	Y11
M16	Q11
M17	S17
M18	Q7
N4	W3
N6	N8
N6	U2
N14	Z12
N15	V3
N16	P16
P6	P8
P6	V1
P14	U3
P15	S4
P16	Q13
P24	R24
P30	W27
Q8	Y16
Q9	U9
Q10	T15
Q14	V19
Q9	S19
R24	S26
S19	V19
S25	V27
S27	S28
S29	S30
T15	U15
U15	W16
U28	V17
U30	V28
U33	U34
V29	X27
V31	V32
V33	V34
Y24	Z27
Z1	GRD

↓ SHIELDED TO W16
 ↘ SHIELDED TO L16



MI 70066

Figure 3-125. Pb HT-507B 10112741 (FG 1405) - schematic.
 3-178

WIRING TABLE	
FROM	TO
A17	B17
A17	Q10
A18	B5
A19	U29
B1	Z17
B2	B18
B3	Q16
B4	F18
B6	C18
B7	E18
B8	G18
B16	B21
B19	M11
C19	T30
D19	T28
E19	Y30
F19	Q24
G10	V15
H16	Q8
H16	W25
H18	J19
J8	H17
J16	Q8
J17	M2
J18	L4
J19	L18
K17	L18
K17	Q13
K18	T17
L2	L3
L3	L4
L16	M16
L17	M8
M1	M2
M4	M5
M5	M6
M6	M7
M7	M8

WIRING TABLE	
FROM	TO
M16	Q16
N6	N7
N6	U18
N7	N8
N9	Z18
N10	Z16
N16	P16
P7	P8
P8	P18
P9	W18
P10	P11
P10	U9
P16	Q13
P24	S25
Q1	X1
Q2	T2
Q7	R7
Q9	W10
Q11	S11
Q11	X17
Q12	V18
Q14	T15
Q16	T18
S25	Y17
S26	U27
S29	S30
T33	T34
U17	V18
U27	V27
U33	U34
V28	V29
V30	W17
V33	V34
W27	W29
W33	W34
Y27	Y29
Y33	Y34
Z1	GRD

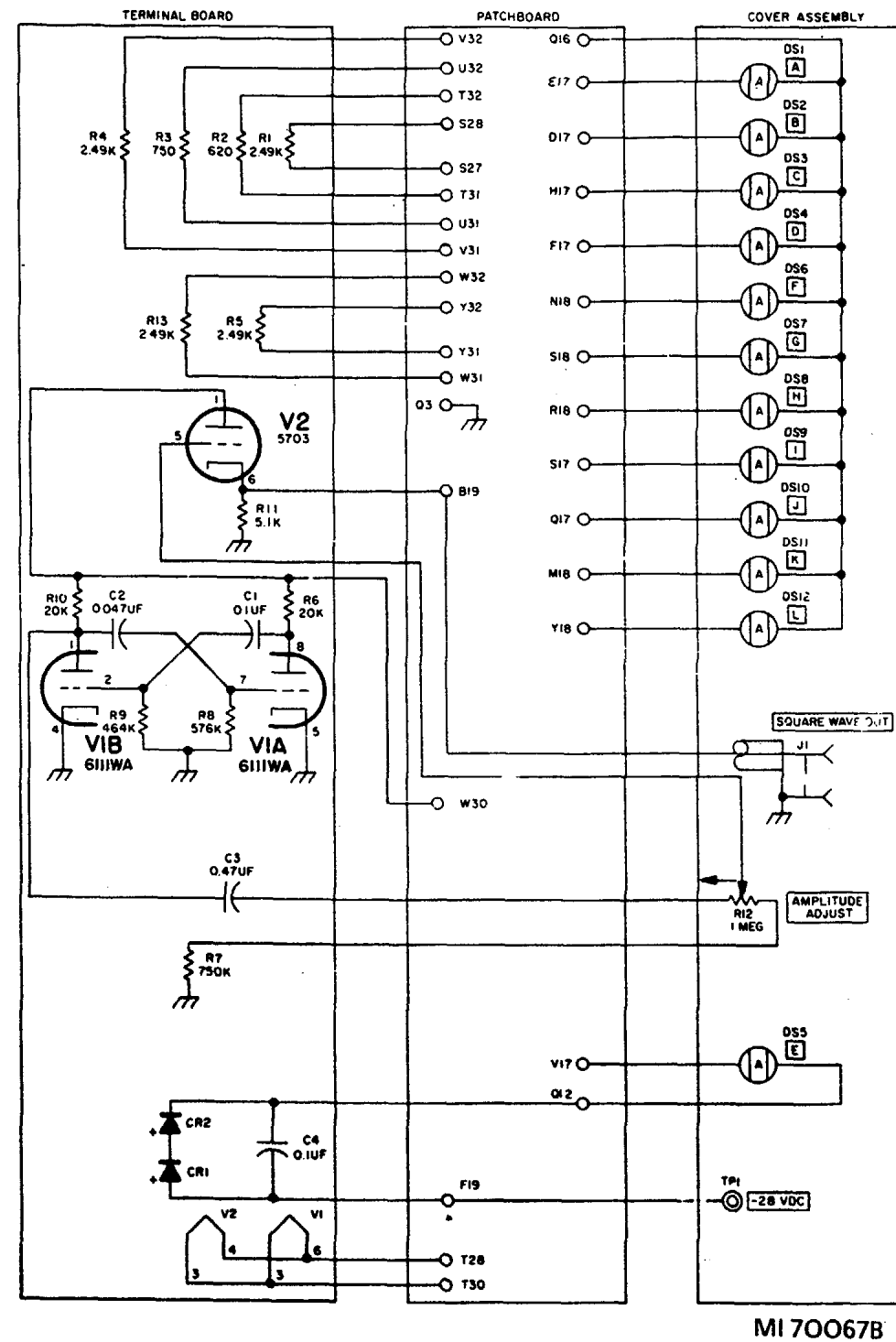
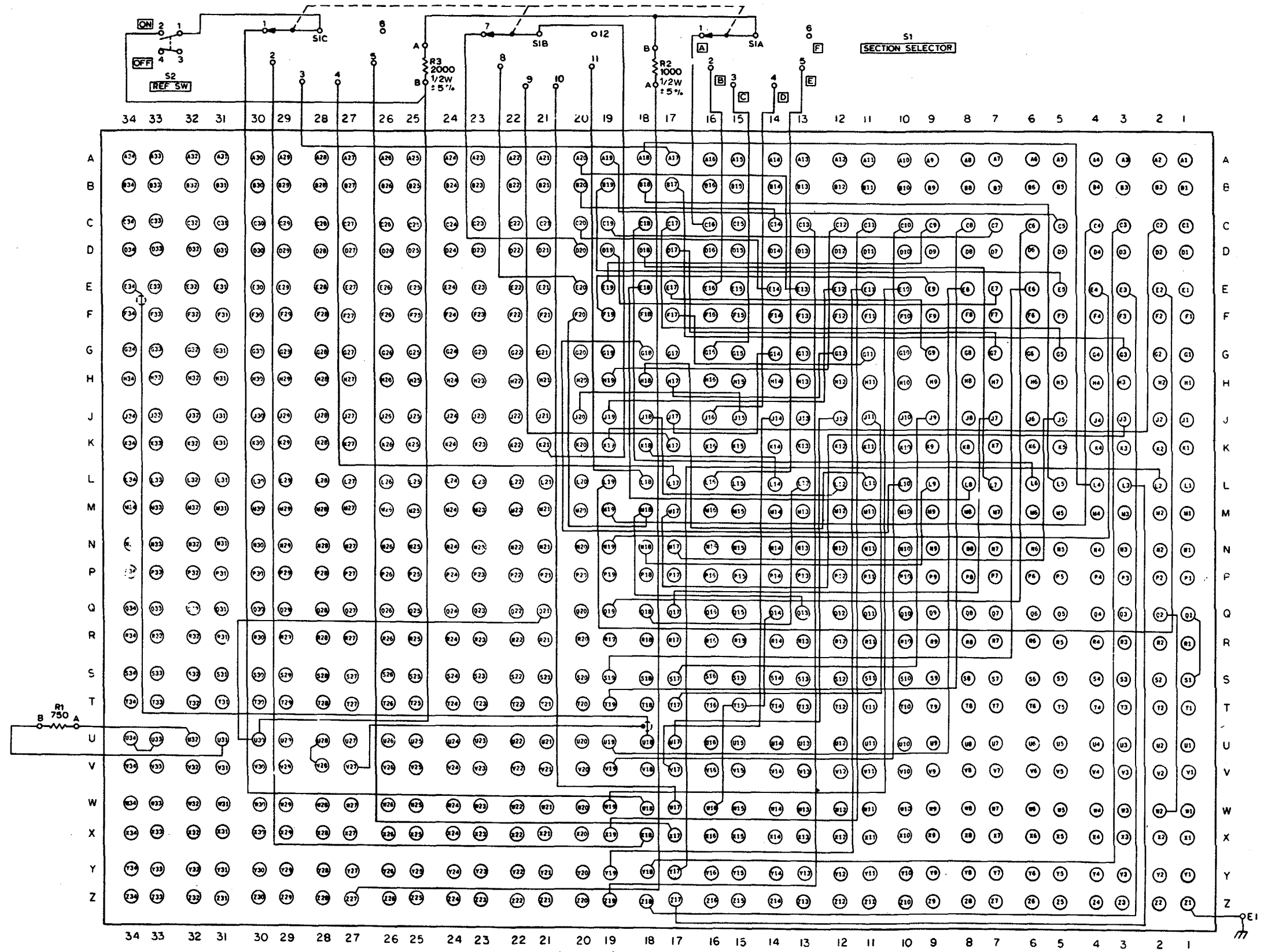

Figure 3-126. Pb HT-509A10111392 (FG 1415) - schematic.



MI 70068

Figure 3-127. Pb HT-510A 10675079 (FG 1420) - schematic.
3-180

WIRING TABLE	
PIN NO.	
FROM	TO
A1	A17
A2	Q17
A3	D18
A4	F18
A5	T17
A6	C17
A7	F17
A8	W17
A9	K18
A10	Q18
A11	Y17
A12	J17
A18	C8
A26	E34
B1	B17
B2	S17
B3	E18
B4	G18
B5	U17
B6	D17
B7	K17
B8	Z17
B9	M18
B10	P18
B11	B18
B12	M17
B26	H26
C1	E17
C2	V17
C3	J18
C4	L18
C5	X17

WIRING TABLE	
PIN NO.	
FROM	TO
C6	H17
C7	L17
C9	N18
C10	R18
C11	C18
C12	N17
C26	M21
G26	H26
G26	X18
H18	L26
H18	U18
H26	V27
M21	P17
P17	S18
Q3	U3
Q3	W4
Q10	W10
Q12	Y11
Q13	T18
Q14	W16
S18	Y18
Y18	W18
W18	Z18
Z1	GRD

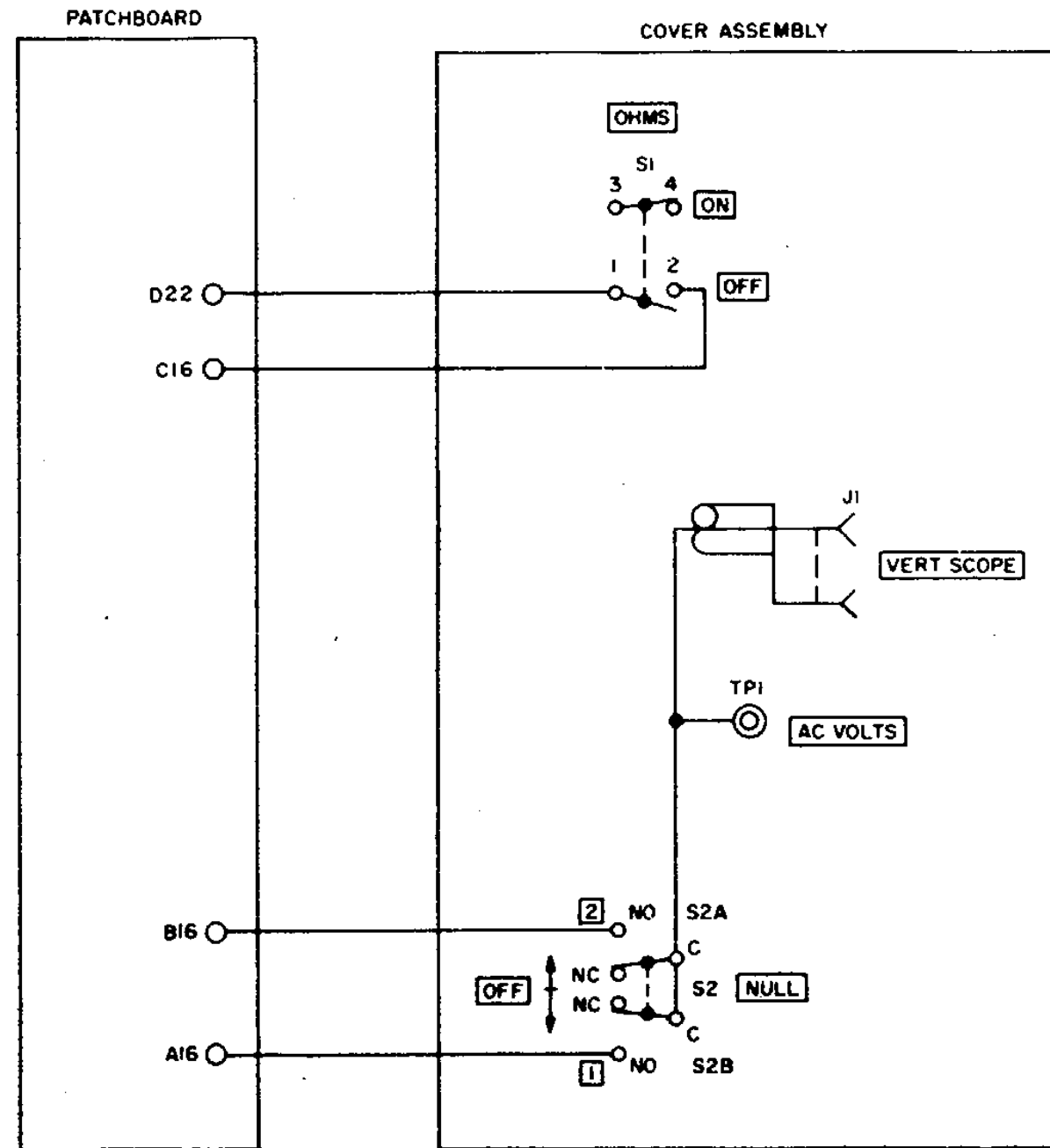

MI 70069

Figure 3-128. Pb HT-512 10109957 (FG 1425) - schematic

WIRING TABLE		WIRING TABLE	
FROM	TO	FROM	TO
A1	A2	H1	Z18
A1	A3	H2	H4
A1	K17	H4	H5
A3	A4	M16	L1B
A4	A5	H17	T17
A16	U28	J1	J2
A17	D29	J1	M21
A24	D25	J2	J4
A29	A30	J4	J5
A29	A34	J16	K18
B2	B4	J29	J31
B4	B5	J31	R30
B5	H17	K10	W17
B16	Q16	K16	T17
B23	D16	K32	L32
B24	C16	K33	R34
B29	B30	K34	L34
B29	D34	L32	Q34
C1	C2	L33	P34
C1	J17	L34	N34
C2	C4	M18	U18
C4	C5	M21	S18
C17	F29	N18	V18
C18	D17	P18	X18
C23	H23	P23	Y23
C30	Y18	Q5	Y6
D1	D2	Q7	R7
D1	L17	Q9	U15
D2	D4	Q10	V17
D4	D5	Q12	T18
D17	E17	Q13	R16
D29	U17	Q16	T28
D30	D32	Q18	W18
D34	F29	R28	U29
E1	E2	R30	U29
E1	N17	S18	Z17
E2	E4	T15	U15
E4	E5	T31	T32
E16	X24	T33	T34
E17	E18	U29	V28
E17	F17	U33	U34
E25	T29	V19	V20
F4	S17	W27	W29
F16	Z30	W33	W34
F17	G17	X27	X30
G2	G3	X27	Y24
G3	G4	X33	X34
G3	Q17	Y27	Y29
G4	G5	Y30	Z23
G16	Z24	Y31	Y32
G17	G18	Y33	Y34
G17	J18	Z1	GRD
G17	Q14	Z27	Z29
H1	H2	Z33	Z34

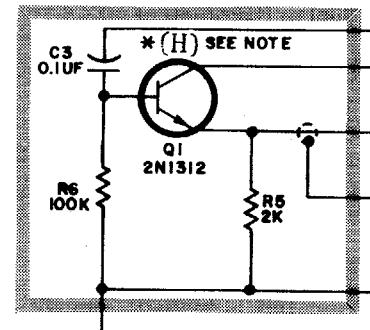

Note. Refer to appendix B for serial number effectivity.

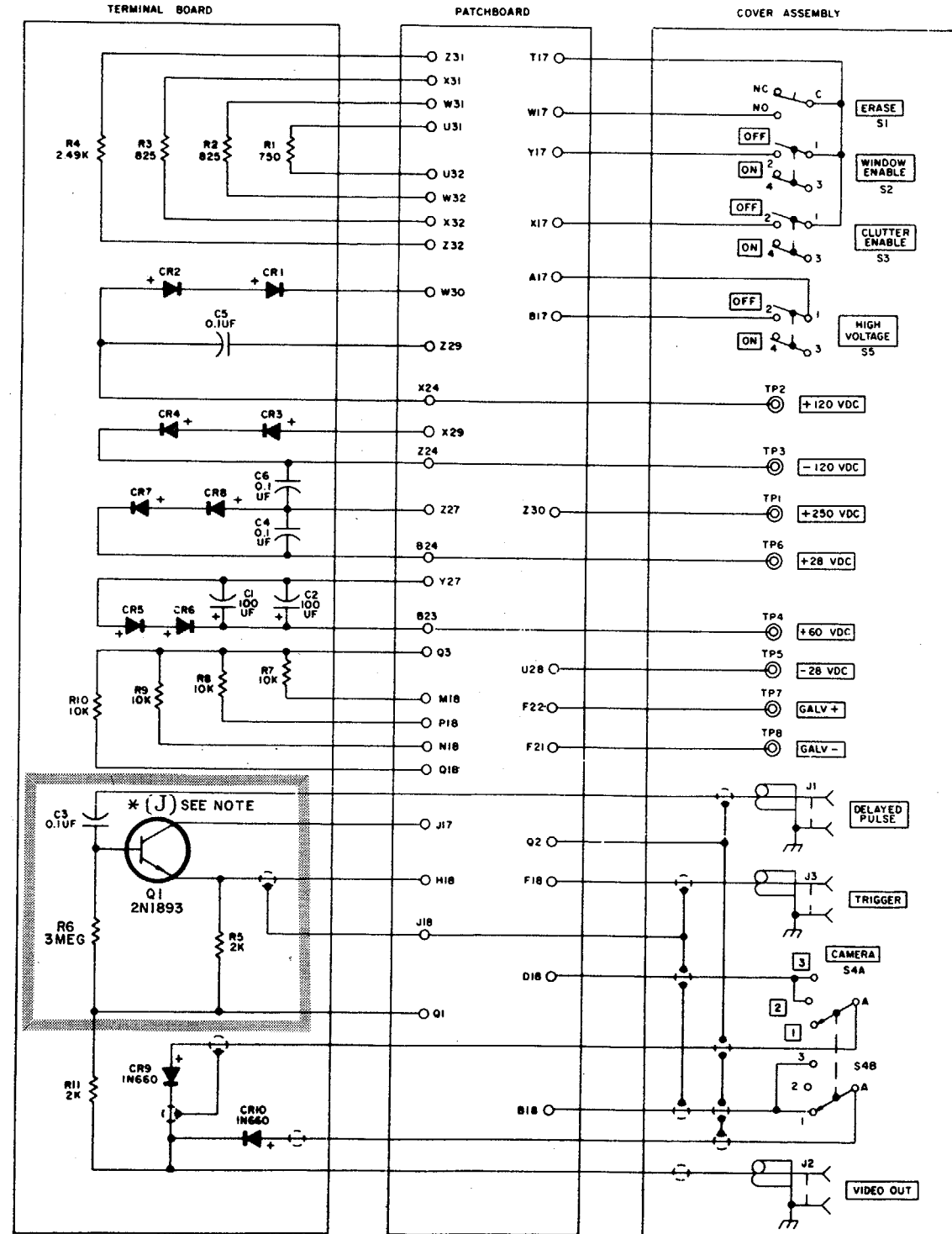

MS 309270

Figure 3-129. Pb HT-513A 10111926 (FG 1430) - schematic.

WIRING TABLE	
PIN NO.	
FROM	TO
A17	M 4
A29	A 34
B17	Q14
B29	D 34
D17	M 3
E 8	E 9
E 9	E10
E10	E11
E11	E12
E12	E13
E13	W19
E16	E21
E 34	L24
F 8	F10
F10	F11
F11	F12
F12	F13
F13	X19
F16	K23
F29	J17
G 8	G 9
G 9	G11
G11	G12
G12	G13
G13	J19
H 8	H 9
H 9	H10
H10	H12
H12	H13
H13	M19
H16	V19
J 8	J 9
J 9	J10
J10	J11
J11	J13
J13	L19
J16	U19
J23	K24
K 8	K 9
K 9	K10
K10	K11
K11	K12
K12	K19
K16	X25
K17	M16
K 32	Q 34

WIRING TABLE	
PIN NO.	
FROM	TO
K 33	P 34
K 34	N 34
L 23	V27
M 1	M 3
M17	Y 30
N 1	U 1
N 3	N 4
N 4	V 1
N 8	U11
N 9	N10
N 9	V 3
N10	N11
N11	N12
N12	N13
N16	P16
N19	Q11
P 1	S 2
P 3	U 2
P 4	T 2
P 8	U10
P 9	P10
P 9	T 4
P10	P11
P11	P12
P12	P13
P16	Q13
Q12	R16
Q30	Q31
R16	T15
T15	U15
U15	W16
U19	U29
U23	V29
U28	V28
U33	U34
V19	V23
V27	V30
V31	V32
V33	V34
W27	W29
W33	W34
Y25	Z27
Y27	Y29
Y33	Y34
Z 1	GRD

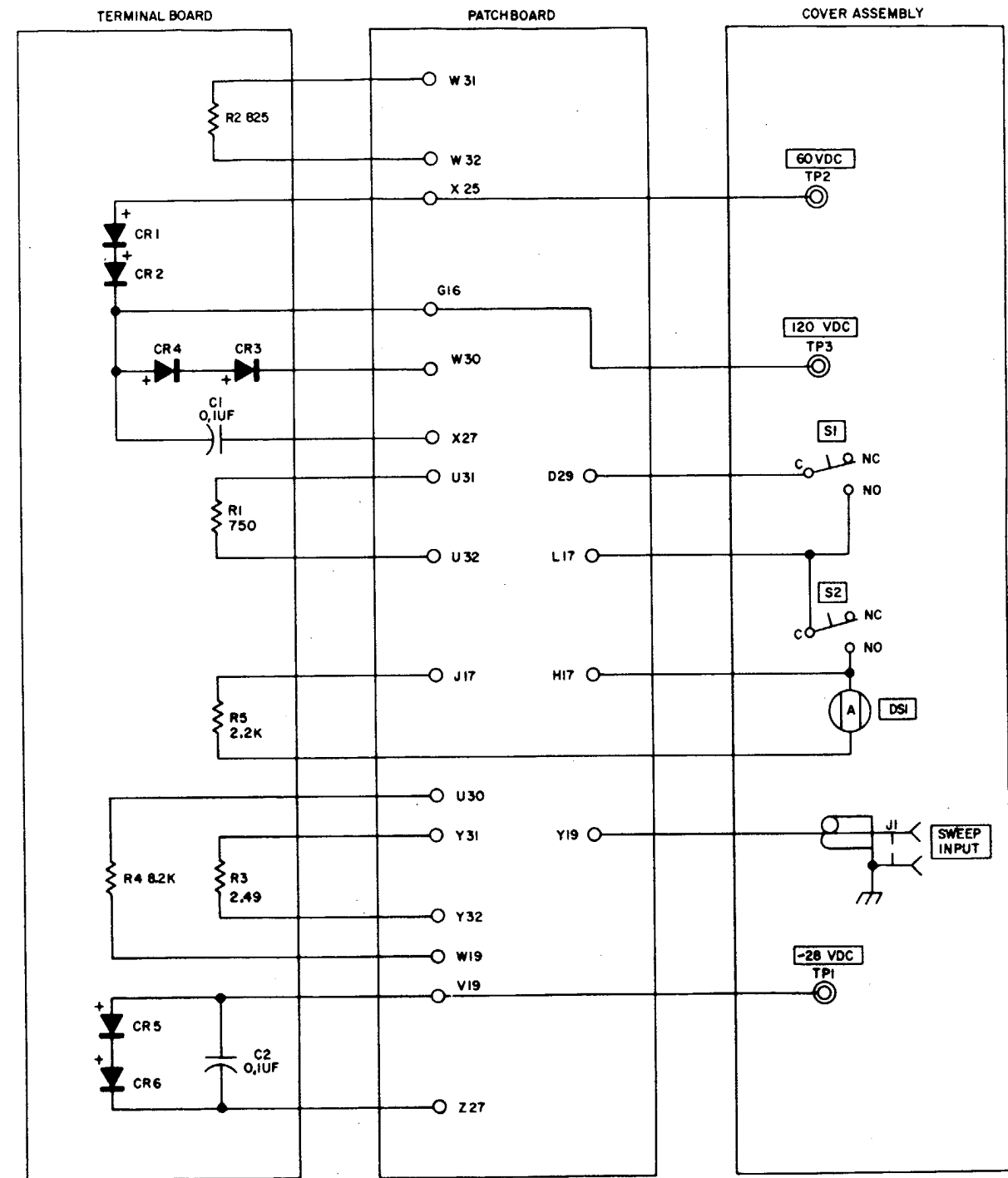

MI 70071

Figure 3-130 Pb HT-514A 10111395 (FG 1435) - schematic.

WIRING TABLE		WIRING TABLE	
FROM	TO	FROM	TO
A1	M17	M12	U10
A2	A6	M16	Q7
A3	A5	M20	P20
A4	J17	N1	N2
A5	E17	N1	V1
A6	A18	N2	N3
A7	M17	N3	N4
A11	B18	N5	N6
A16	B21	N6	T1
A17	Q24	N8	X9
A19	E2	N9	N10
A20	E8	N9	R7
B1	B7	N11	U1
B8	N17	N16	P16
B16	E21	N17	N11
B17	C17	P1	P2
B19	L2	P2	P6
B20	L8	P3	P4
C17	Q12	P4	P5
C19	E3	P5	P11
C20	E9	P6	P7
D19	L3	P7	T2
D20	L9	P8	X7
E1	E20	P9	P10
E4	E19	P9	U9
E5	G19	P11	U2
E6	J19	P16	Q6
E7	Y19	P20	Q11
E34	L20	P24	V29
F19	L4	P32	Q34
F20	M20	P33	R34
H7	U29	Q3	V3
H9	L5	Q4	T4
J10	Y16	Q10	W16
J11	J12	Q13	T15
J12	U15	Q14	R16
J16	K16	Q16	R20
K8	T11	S25	U27
K11	K12	S26	X23
K12	W11	S27	S28
K16	Q9	S29	S30
K19	L6	U27	V27
L7	Z19	U33	U34
M1	M7	V28	V30
M7	M8	V31	V32
M8	M9	V33	V34
M9	V10	Z1	GRD
M11	M12		

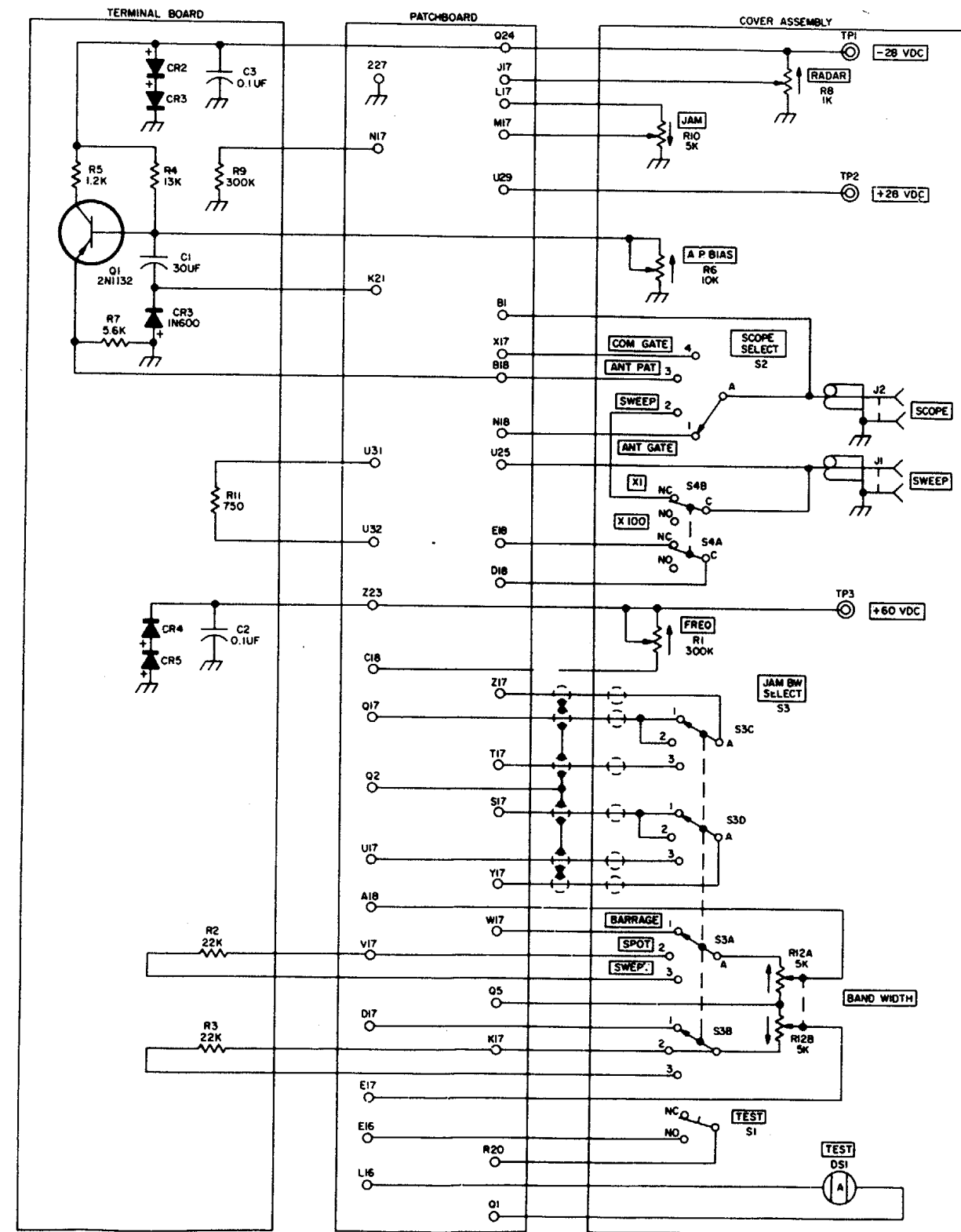

MI 70072

Figure 3-131. Pb HT-513A 1011 931 (FG 1445) - schematic.
3-184

WIRING TABLE	
FROM	TO
A3	A9
A9	B20
A10	C20
A11	A12
A12	A13
A13	A14
A14	D20
A16	A17
A16	H19
A19	E23
B3	Z16
B4	Y16
B5	N19
B6	T19
B9	W19
B12	Q19
B13	D19
B14	V19
B16	B19
B17	E19
B19	C19
C17	D17
C19	F19
D17	Q14
D22	H19
D23	V29
E17	K19
E19	T30
F19	Q11
H19	U29
J31	R30
K19	Y30
K32	Q34
K33	P34
K34	N34
N1	V11
N3	N5
N3	P1

WIRING TABLE	
FROM	TO
N4	V10
N5	N6
N6	U10
N9	N10
N9	P1
N10	N11
N11	N12
N12	N13
N13	N14
N16	P16
P4	P5
P5	P6
P6	P9
P9	S11
P10	P11
P10	T11
P11	P12
P12	P13
P13	P14
P16	Q13
Q3	S3
Q5	V4
Q7	R7
Q9	U9
Q10	T15
R30	X27
T15	U11
T28	V28
T33	T34
U27	V27
U33	U34
V27	V30
V31	V32
V33	V34
W27	Y29
Y33	Y34
Z1	GRD

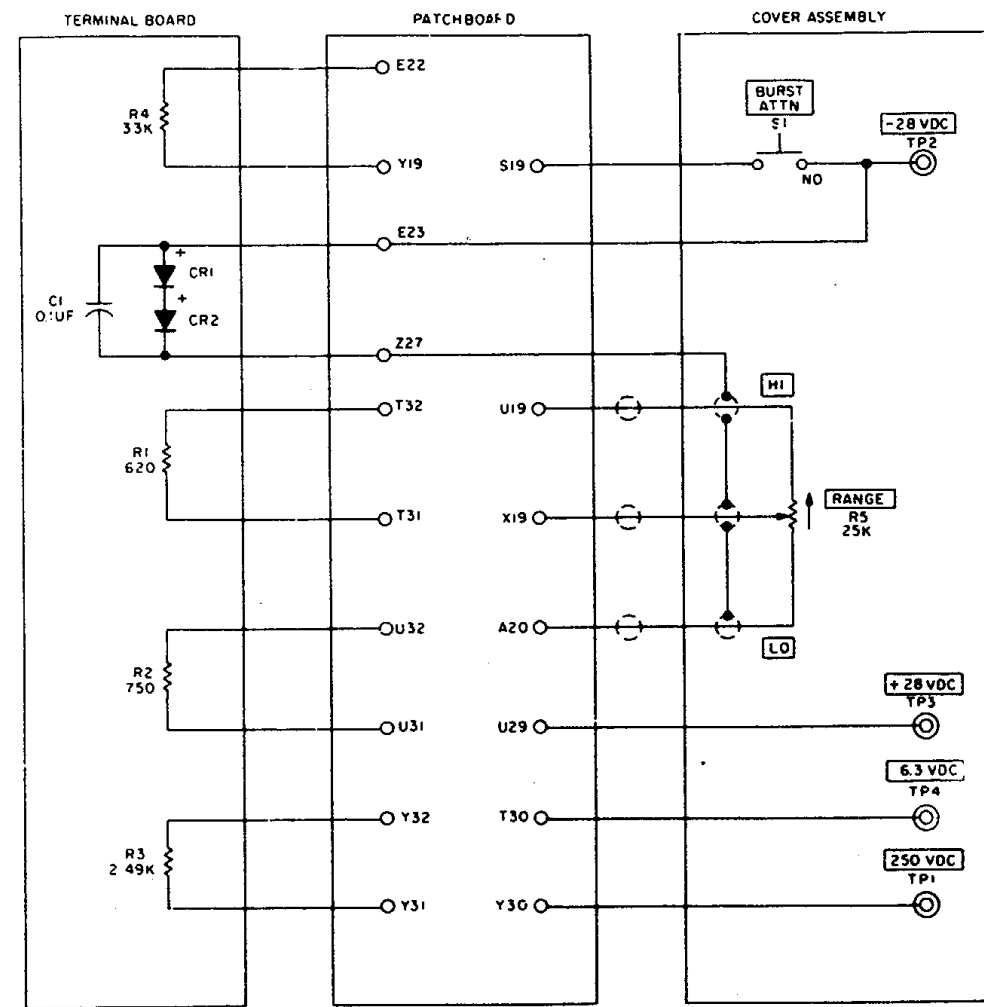

MI 70073

Figure 3-132. Pb HT-552B 10112743 (FG 1450) - schematic.

WIRING TABLE	
FROM	TO
A1	U17
A16	A22
A17	A19
A17	N24
B17	B19
B17	C17
B19	C19
C17	D17
C20	H11
D17	F17
D19	E16
D19	Q16
D20	H9
E3	M17
E17	E19
E19	T29
F1	F2
F2	K17
F16	K19
F17	F19
F17	Q12
G8	G9
G9	G10
G10	V19
G16	Q9
H6	Q19
H7	M19
H8	S19
H10	Z19
H17	H19
H19	U29
J1	J2
J2	V10
J3	J5
J5	J6
J6	J7
J7	J8
J8	J9
J9	J10
J10	J11
J11	U10
J16	K16
J29	R30
J31	R30
K1	K6
K2	K3
K2	U11
K6	K7
K7	K8
K8	K9
K9	K10
K10	K11
K11	S11
K16	Q11
K19	Y30
K32	L32
K32	Q34
K33	P34
K34	L34
K34	N34
L1	W2
L16	M16

WIRING TABLE	
FROM	TO
L33	R34
M1	S1
M2	Y16
M16	N16
M24	V29
N1	X9
N2	U9
N16	P16
P1	X7
P2	R7
P16	Q13
Q10	T15
Q17	X23
Q32	R34
R30	V30
T15	U15
T27	V27
T33	T34
U27	V28
U33	U34
V27	V30
V31	V32
V33	V34
W23	W30
W27	W29
W31	W32
W33	W34
X27	Y29
Y33	Y34
Z1	GRD

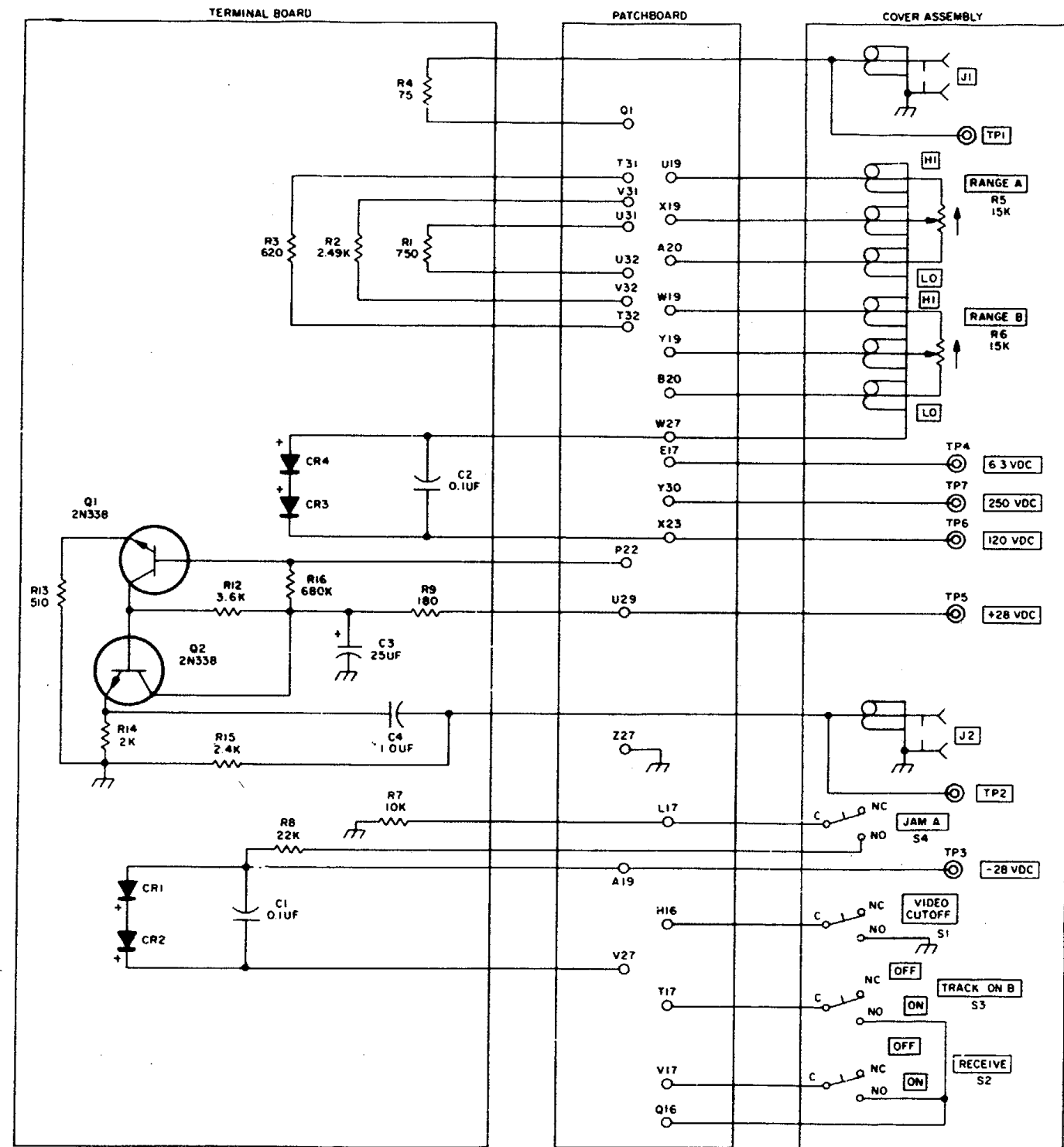

MI 70074

Figure 3-133. Pb HT-526A 10111410 (FG 1455) - schematic.

WIRING TABLE	
FROM	TO
A1	Y17
A19	Z30
A20	B6
B3	G20
B4	Z20
B16	B21
C3	Y20
C4	Y19
C16	E21
D4	D5
D5	W19
D16	W25
E17	E20
E20	Z24
F17	V24
H17	U30
J30	N1
K16	L16
K32	Q34
K33	P34
K34	N34
L1	V10
L3	L4
L4	L6
L6	T2
L16	Q11
M1	U11
M3	M4
M3	X1
M4	M6
M5	Y16
M16	N16
M16	Q12

WIRING TABLE	
FROM	TO
N3	N4
N4	T4
N5	T11
N16	P16
N17	N19
N17	Q14
P1	Q30
P3	X3
P4	V3
P5	W10
Q7	R7
Q9	U9
Q13	T15
Q19	T29
S19	T28
T15	U15
T33	T34
U28	V28
U33	U34
V27	V29
V30	Y23
V31	V32
V33	V34
W24	X23
W27	W29
W33	W34
Y24	Z27
Y27	Z29
Z1	GRD
Z33	Z34

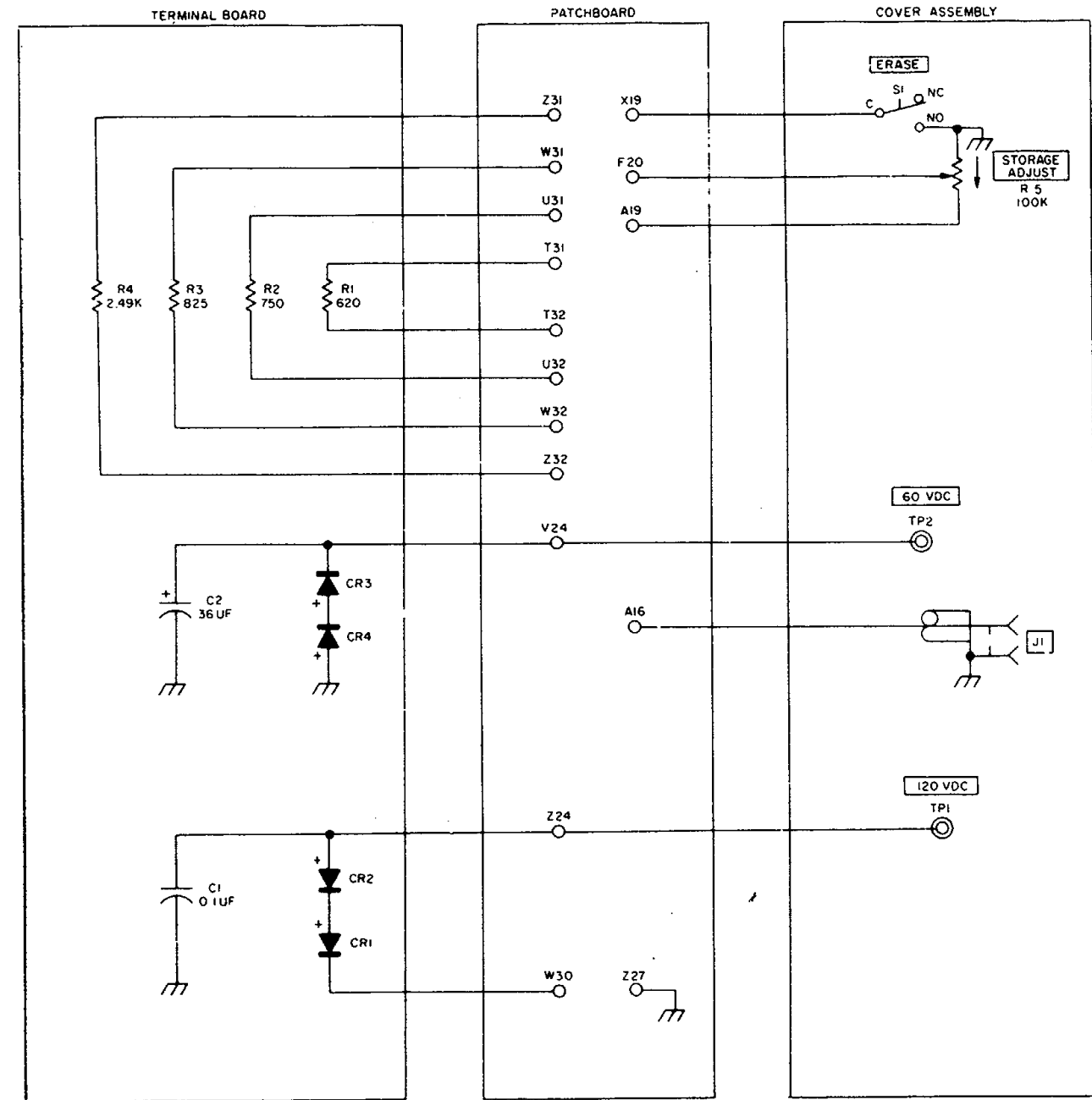

MI 70075

Figure 3-134. Pb HT-529 10110808 (FG 1460) - schematic.

WIRING TABLE		WIRING TABLE		WIRING TABLE	
FROM	TO	FROM	TO	FROM	TO
A1	A2	E3	E7	M17	Q13
A2	A3	E4	F5	M19	Q16
A2	A4	E4	F18	N3	N4
A3	C17	E5	E6	N3	U2
A5	A6	E6	E7	N4	N6
A5	K17	E16	F16	N5	P4
A6	A7	E24	M24	N5	V1
A16	F17	F5	F6	N7	X9
A17	A19	F6	F7	N8	U3
A17	H16	F16	G16	N13	U9
A18	E7	F19	J10	N16	P16
A19	U23	G6	G7	N24	P24
A20	J17	H5	N20	P2	P7
A23	Q24	H17	H19	P3	P4
B3	B4	H17	U29	P5	T2
B3	J19	H19	N24	P5	P11
B4	B6	J4	J10	P6	N11
B5	B6	J11	T19	P6	U1
B6	B8	J17	K6	P7	V10
B7	C17	J20	W25	P12	P13
B17	F22	K3	Z19	P13	W19
B18	G7	K4	X19	P16	Q12
B19	C19	L1	L5	P32	Q34
B21	K16	L3	L4	P32	R32
B23	M6	L4	L6	P33	R34
C2	C3	L4	T4	P34	Q32
C3	C4	L5	U10	Q6	Y6
C4	C5	L6	L12	Q8	R8
C5	C6	L7	X7	Q10	Z16
C6	C7	L8	U4	Q14	T15
C7	H17	L12	T10	Q20	X23
C16	L17	L13	T7	S25	V27
C17	Q14	L16	M16	S26	W23
C19	F22	M3	M4	S27	S28
D1	D2	M3	W3	S29	S30
D2	D3	M5	T11	T15	U15
D2	D4	M7	M12	U28	V28
D3	G18	M7	N1	U33	U34
D5	D6	M7	W11	V23	V29
D5	S17	M9	M10	V28	V30
D6	D7	M9	T11	V31	V32
D16	T17	M10	M11	V33	V34
D17	E16	M12	M14	Z1	GRD
D17	U29	M13	M14		
D18	H7	M16	Q11		

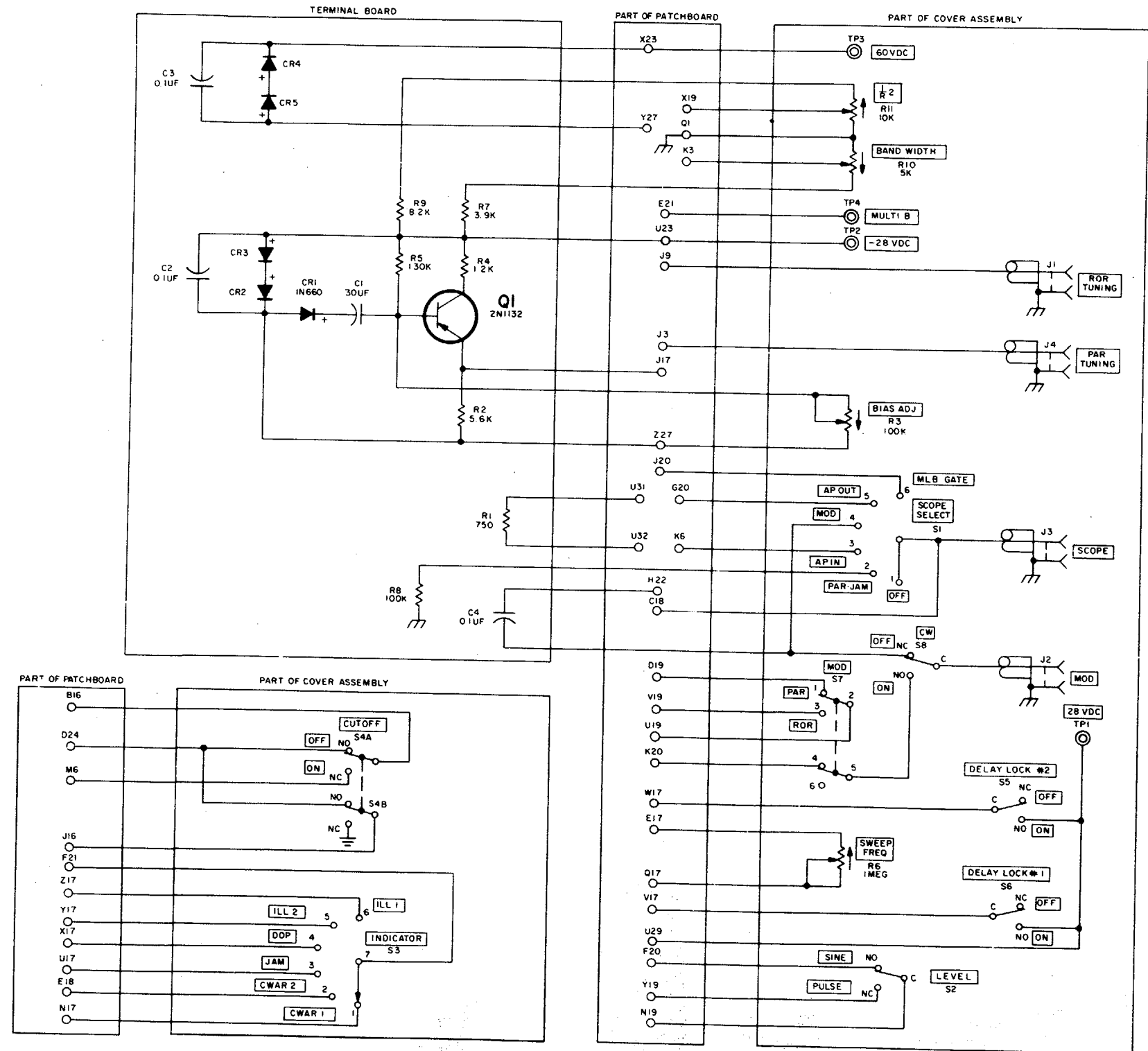

MI 70076

Figure 3-135. Pb HT-530A 10111916 (FG 1465) - schematic.

WIRING TABLE	
PIN NO	PIN NO
FROM	TO
A1	X20
A2	A6
A3	A5
A4	V17
A5	S20
A6	R20
A16	B21
A17	T16
A18	Z20
A19	T24
B1	U25
B16	E21
B17	B19
B17	C17
B19	C19
B20	E17
C19	Q8
D17	E20
F17	G20
F20	X17
H17	H15
H19	U30
J17	K20
K17	L20
L8	W11
L9	V11
L10	S11
L16	M16
M16	Q9
M17	M20
N1	N2
N1	V1
N2	N3
N3	N4
N5	N6
N5	T1
N16	P16
N17	N20

WIRING TABLE	
PIN NO	PIN NO
FROM	TO
P1	P2
P2	P6
P2	T2
P3	P4
P3	U2
P4	P5
P8	Q6
P16	Q10
P20	Q17
Q3	V3
Q4	T4
Q7	V10
Q8	X9
Q11	T15
R20	S17
S20	T17
S25	U27
S26	Y23
S27	S28
S29	S30
T15	U15
U20	V17
U24	V29
U27	V27
U33	U34
V20	W17
V28	V30
V31	V32
V33	V34
X20	Y17
Y20	Z17
Z1	GRD

SHIELDED TO Q5

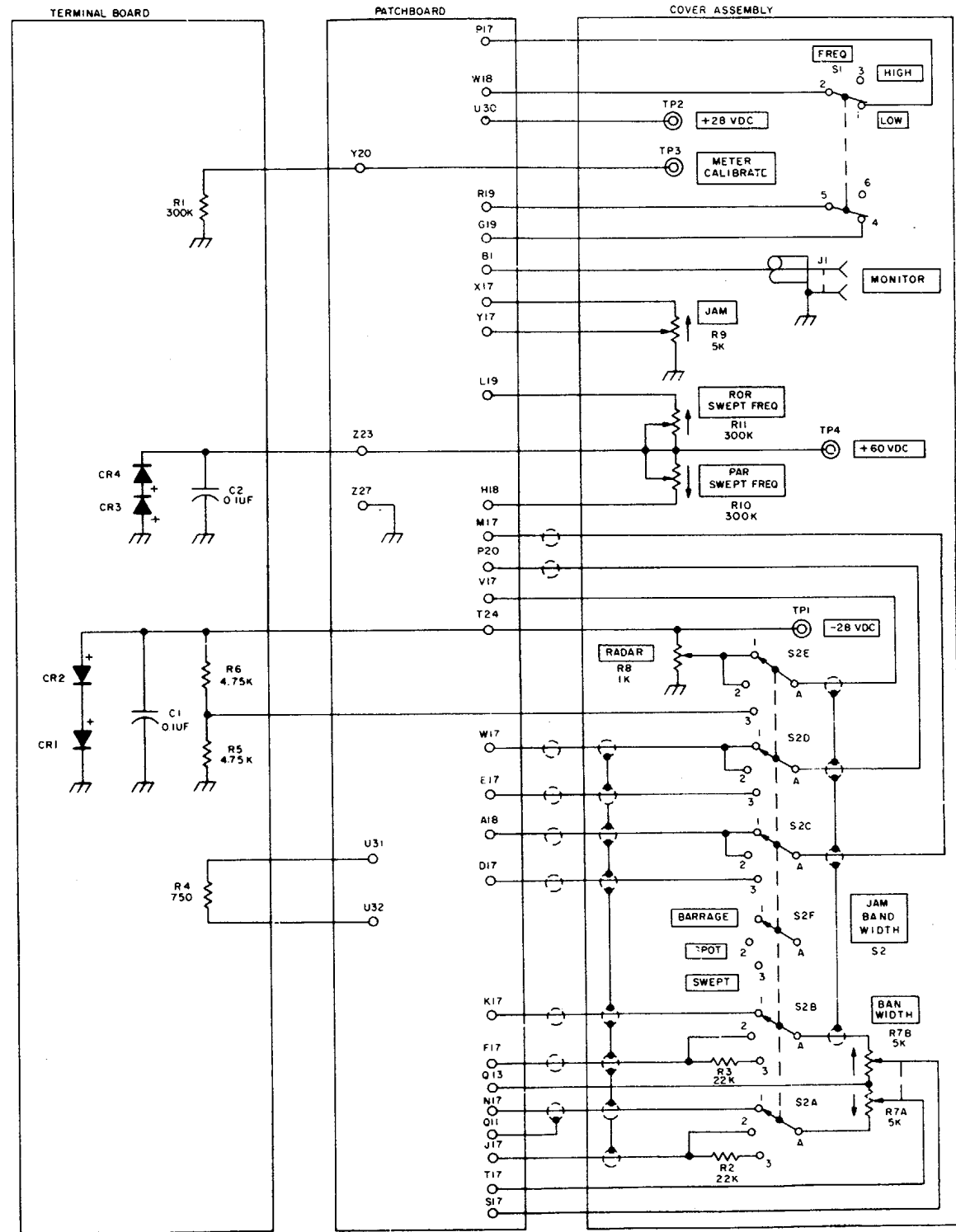

MI 70077

Figure 3-136. Pb HT-532A 1011921 (FG 1470) - schematic.

WIRING TABLE	
PIN NO	
FROM	TO
A 3	F17
A 4	E17
A16	H16
A17	A19
A19	V23
B17	B19
B17	C17
B19	C19
C17	Q13
H17	H19
H19	U29
H31	N1
K32	Q34
K33	P34
K34	N34
L 2	L 3
L 2	L31
L 3	L 4
L16	Q10
L19	X23
M1	M2
M2	M3
M3	T10
M6	N16
N6	Q12
P1	P2
P1	T11
P2	P3
P16	Q14
P32	Q34
P33	R34
Q1	U1
Q2	U2
Q7	X7
Q8	X9
Q14	T15
Q30	X27
S25	V28
S26	Z23
S27	S28
S29	S30
T15	U15
T23	T24
T23	V29
U28	V27
U33	U34
V23	V24
V30	W27
V31	V32
V33	V34
Z1	GRD

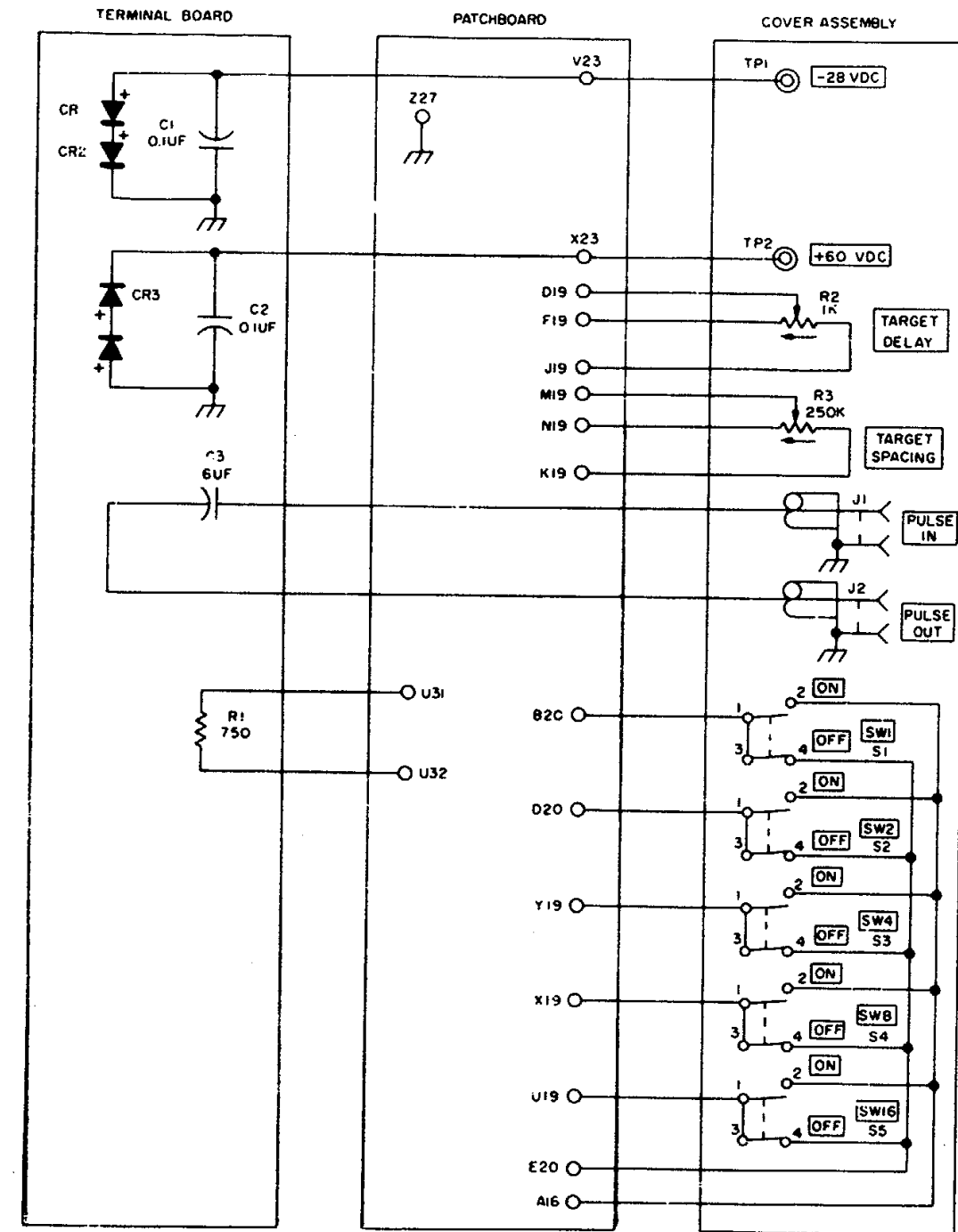

MI 70078

Figure 3-137. Pb HT-533A 10111911 (FG 1475) - schematic.

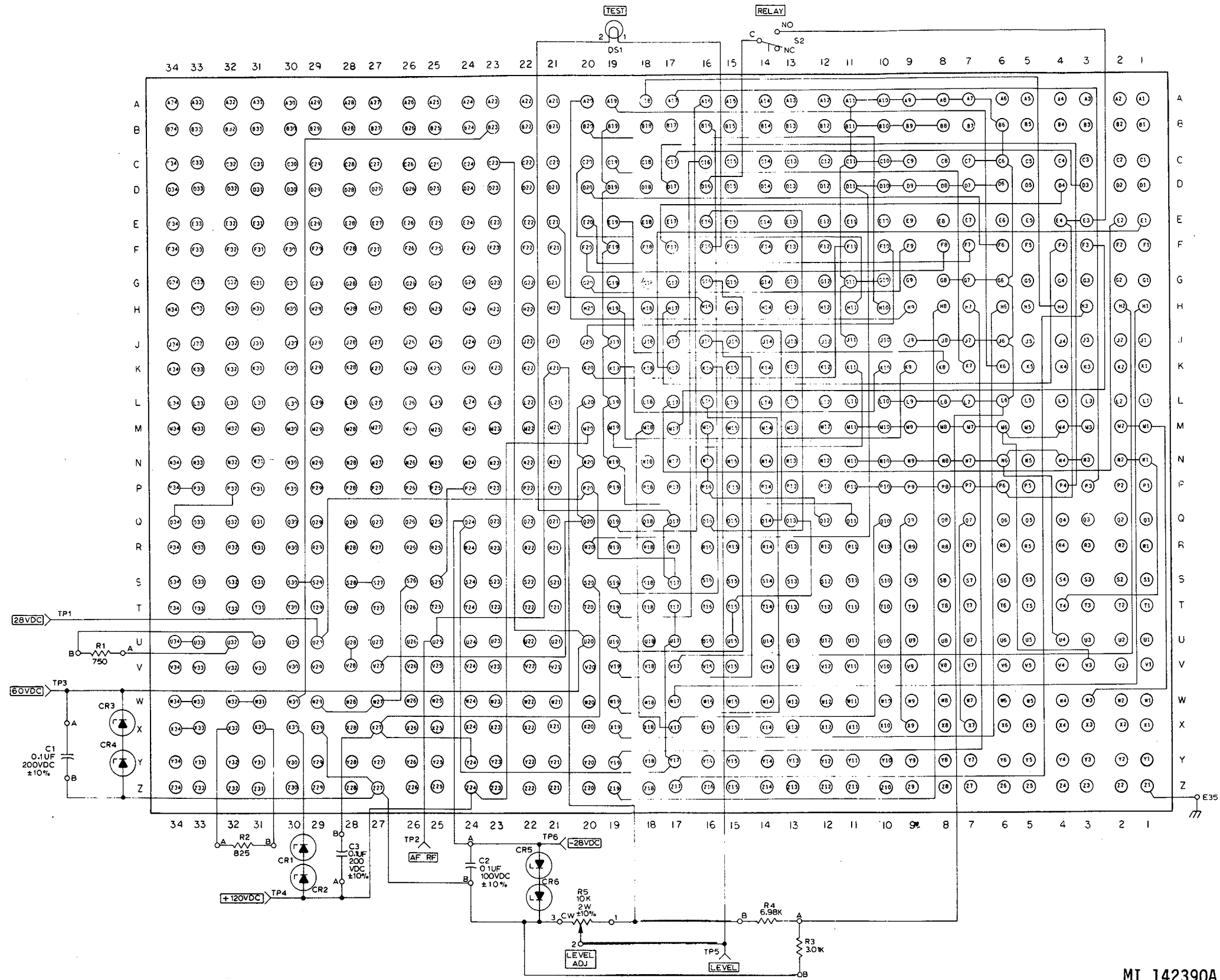

MI 142390A

Figure 3-138. Pb HT-534B 10288439 (FG 1480) - schematic.

WIRING TABLE	
PIN NO.	
FROM	TO
A2	D19
A2	P3
A4	P5
A6	P7
A8	P9
A10	P11
A12	P13
A16	B16
A17	D18
A18	Q7
A18	Z17
A19	N3
A20	P3
B2	B3
B3	F19
B4	B5
B5	N19
B6	B7
B7	W19
B8	B9
B9	C20
B10	B11
B11	K20
B12	B13
B13	R20
B17	B18
B18	X17
B19	C3
B20	D8
B21	E16
C2	C3
C4	C5
C5	J19
C6	C7
C7	S19
C8	C9
C9	Y19
C10	C11
C11	E20
C12	C13
C13	Q20

WIRING TABLE	
PIN NO.	
FROM	TO
C16	D16
C17	F18
C18	Q10
C19	M3
D2	E19
D4	M19
D6	V19
D12	P20
D16	E31
D20	M11
D31	F34
E14	M18
E15	P18
E21	F16
F14	N18
F15	R18
F20	N11
F31	W27
G20	P11
H17	U27
H19	N5
K19	M5
L19	P5
L20	M13
M2	M3
M4	M5
M6	M7
M7	Q19
M8	M9
M8	X19
M10	M11
M12	M13
M16	Q8
M20	N13
N2	N3
N4	N5
N6	N7
N6	T19
N8	N9

WIRING TABLE	
PIN NO.	
FROM	TO
N9	Z19
N10	N11
N12	N13
N16	P16
N20	P13
P7	U19
P16	Q9
Q1	U1
Q2	U2
Q3	U3
Q4	U4
Q11	Y17
Q12	Q17
Q13	W16
Q14	T15
Q17	T17
Q24	V30
T17	U17
U29	V27
U33	U34
V28	V29
V31	V32
V33	V34
Z1	GRD

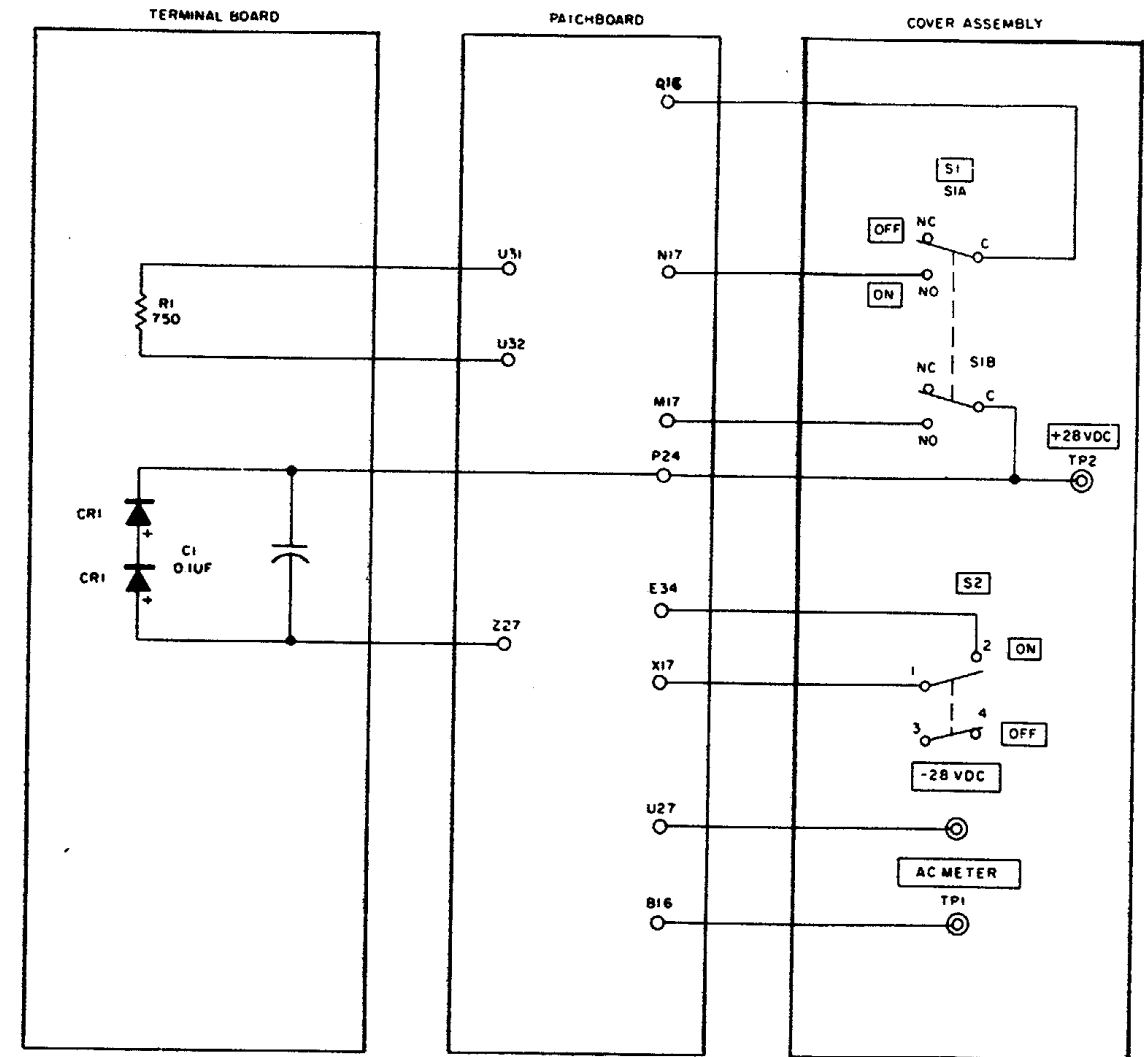

MI 70080

Figure 3-139. Pb HT-537A 10111406 (FG 1485) - schematic.

WIRING TABLE		WIRING TABLE		WIRING TABLE	
PIN NO.		PIN NO.		PIN NO.	
FROM	TO	FROM	TO	FROM	TO
A1	P22	H17	K16	P11	P12
A9	E19	H17	U30	P11	X13
A10	F19	H23	W27	P12	P13
A11	C20	H31	L8	P13	P14
A12	K19	J1	J5	P16	Q12
A13	J19	J1	P30	Q1	V1
A14	H19	J2	J17	Q2	T2
A17	D19	J3	J5	Q3	V3
A17	Q13	J16	L16	Q4	T4
A19	B17	K8	N17	Q7	R7
A19	B19	K17	Y30	Q8	W16
B9	G20	K23	U30	Q9	U9
B10	Q20	K31	L1	Q11	T15
B11	R20	K32	Q34	Q32	R34
B12	V20	K33	P34	T15	U15
B13	Z20	K34	N34	T33	T34
B14	R19	L1	X12	U28	V28
B17	C17	L2	V15	U33	U34
B19	L19	L3	L7	X27	X30
B21	D16	L7	L8	X31	X32
C9	D20	L16	M16	X33	X34
C10	J20	L16	Q10	Y27	Y29
C11	M20	L19	S19	Y33	Y34
C12	S20	M1	M4	Z1	GRD
C13	W20	M1	Y16		
C14	H20	M4	M5		
C17	Q14	M7	M8		
C19	Q16	M8	N30		
D9	E20	M11	M12		
D10	L20	M11	W10		
D11	N20	M12	M13		
D12	U20	M13	M14		
D13	Y20	M19	Q19		
D14	P19	N1	N5		
D17	M24	N2	N4		
E9	F20	N2	U10		
E10	K20	N3	N7		
E11	P20	N5	T10		
E12	T20	N7	N8		
E13	X20	N8	V10		
E14	G19	N11	N12		
E16	E21	N11	Y11		
E17	T29	N12	N13		
E34	M19	N13	N14		
F17	T27	N16	P16		
G11	G12	N24	X29		
G11	Q19	P1	U11		
G12	G13	P2	P3		
G13	G14	P3	P7		
G16	M21	P4	P5		
G23	H16	P4	V11		
H3	H4	P7	P8		
H4	H5	P8	S11		
H5	M17	P9	P10		
H16	J23	P9	Z12		

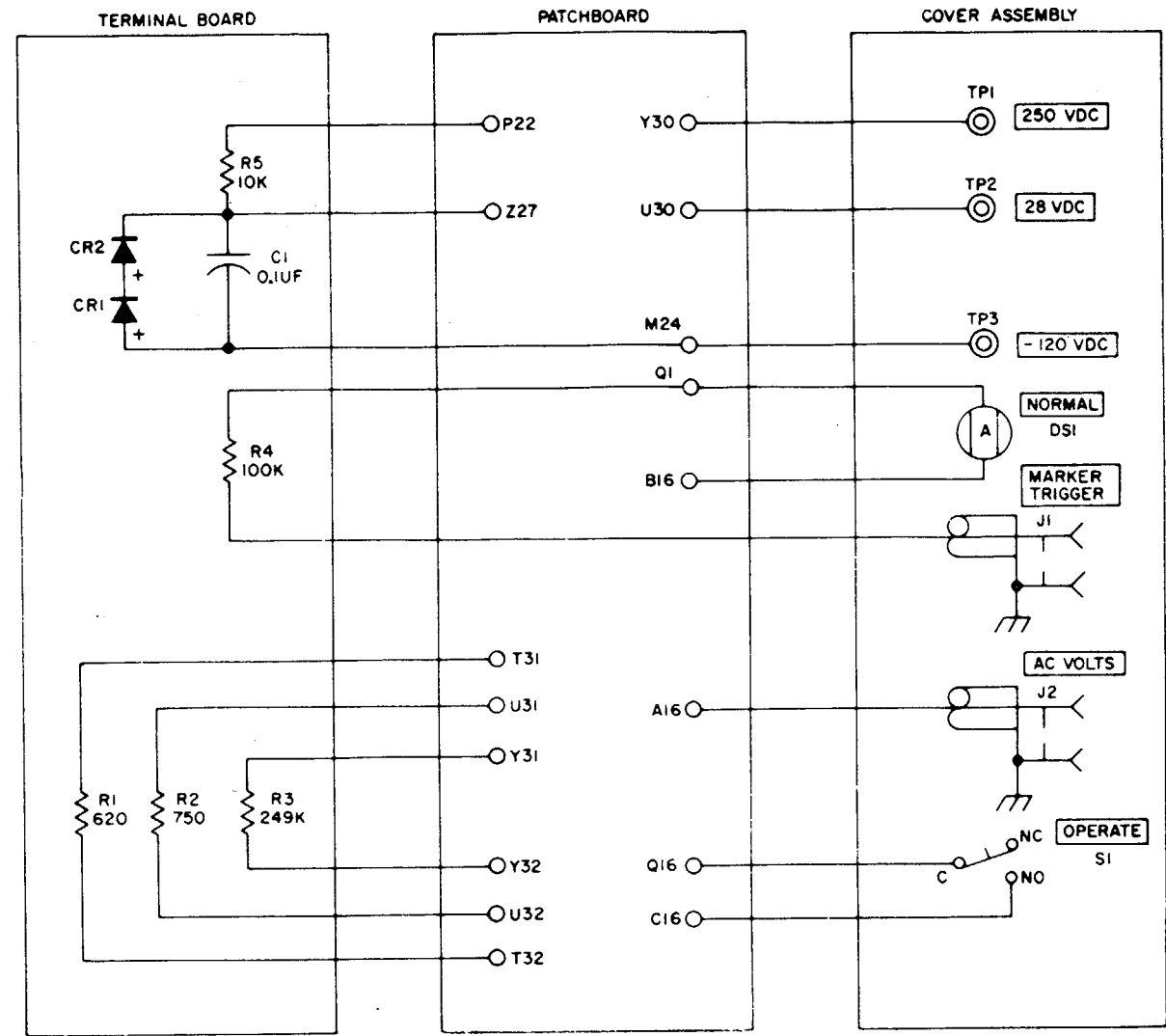

MI 70081

Figure 3-140. Pb HT-538A 10111398(FG 1490) - schematic.

WIRING TABLE	
PIN NO.	
FROM	TO
A1	A5
A2	A7
A2	M9
A3	A4
A3	T10
A4	A6
A5	V10
A16	B16
A17	A19
A17	D7
A19	P24
B1	B2
B1	B7
B2	T11
B3	B4
B4	B5
B5	B6
B6	L9
B16	Q12
C2	C7
C5	C6
C5	K17
C8	C9
C8	V17
C17	C19
C17	Q14
D2	Q2
D16	N18
E17	E19
E19	T29
F17	F19
F19	T27
H17	H19
H19	U29
J29	J31
J29	W27
K32	L32
K33	L33
K34	L34
L8	L9
L9	L11
L9	W11
L10	X11
L12	V11
L16	M16
L32	P32
L33	P34
L34	N34
M8	M9
M9	M10
M10	M11
M10	U10
M10	M12
M16	N16
M17	Q16
N4	N5
N4	N17
N5	N8
N16	Q13
P32	Q34
P33	R34
Q7	U7
Q9	U9
Q11	Z16

WIRING TABLE	
PIN NO.	
FROM	TO
Q14	T15
Q17	Q19
Q24	V29
R28	R30
R28	U27
T15	U15
T33	T34
U27	V27
U33	U34
V28	V30
V31	V32
V33	V34
X27	X29
X33	X34
Z1	GRD

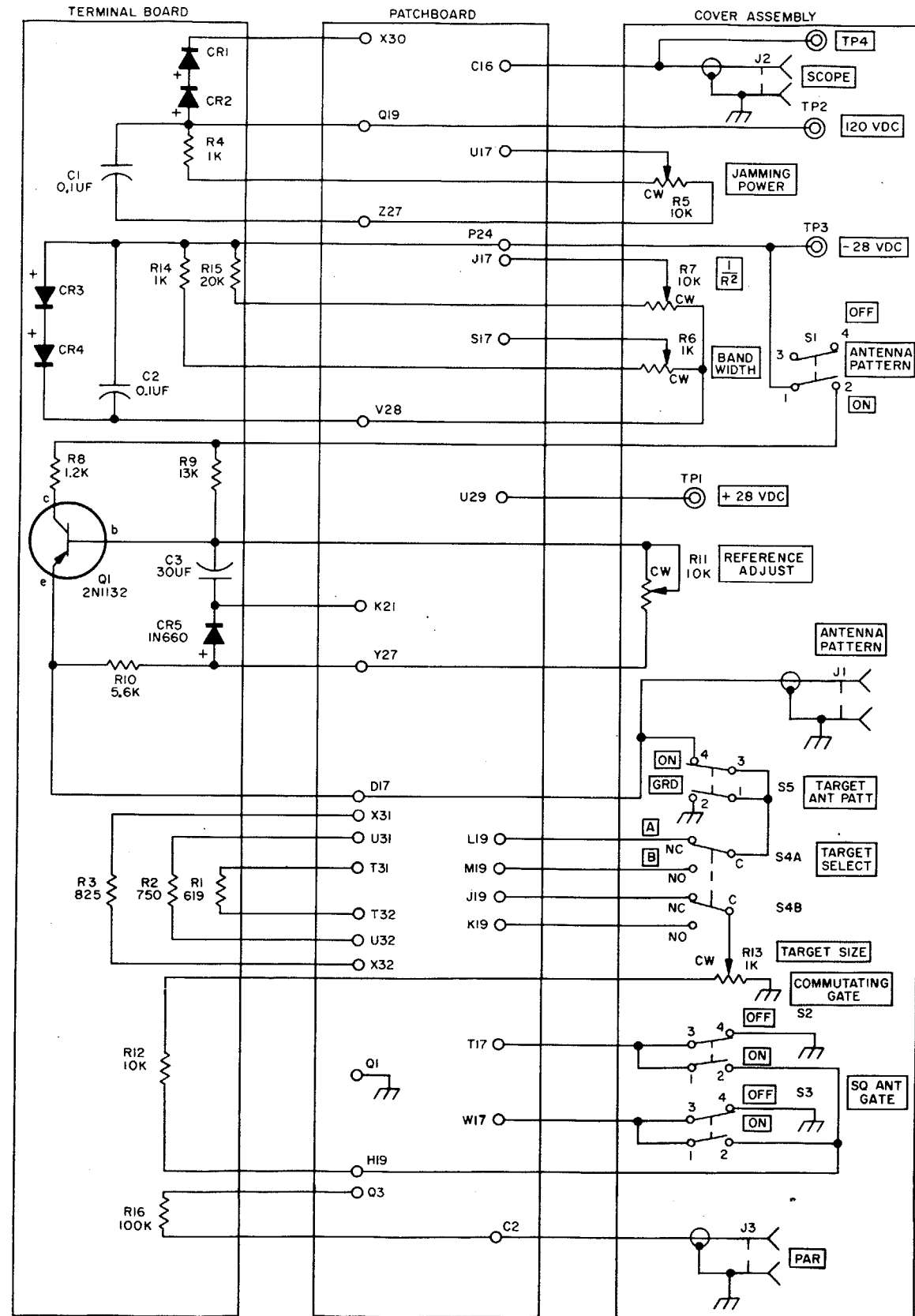
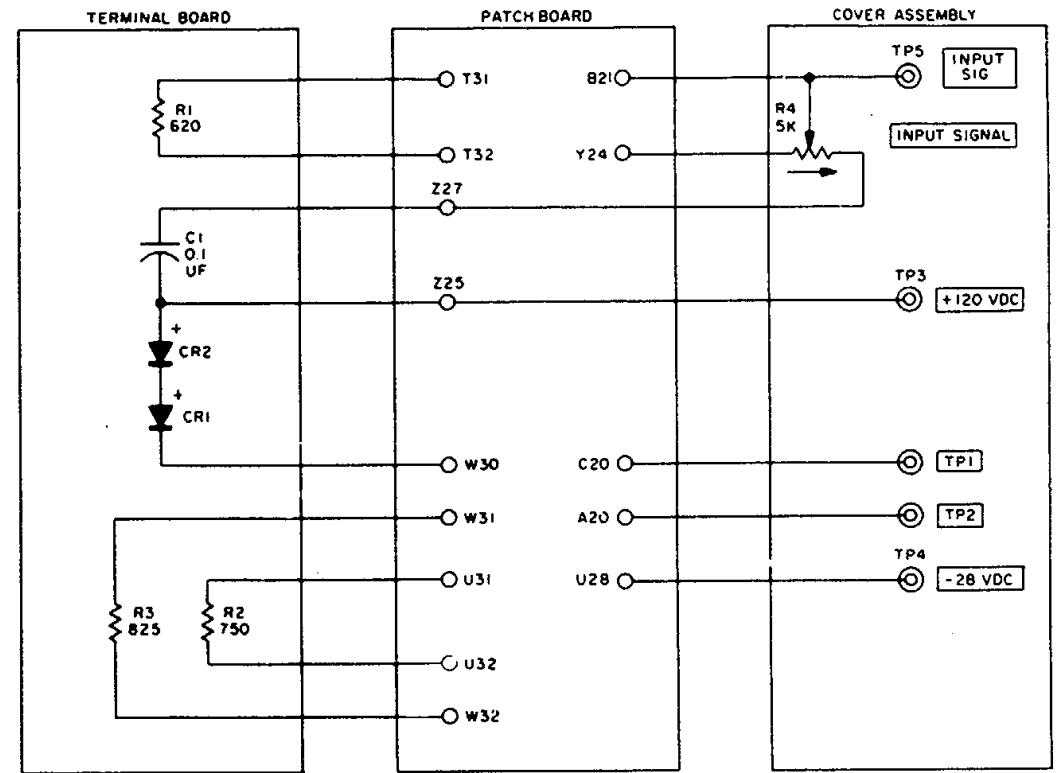

Figure 3-141. Pb HT-540B 10173896 (FG 1495) - schematic.

WIRING TABLE	
PIN NO	
FROM	TO
A1	D17
A2	C17
A3	F17
A4	E17
A5	K17
A6	A19
A7	S20
A8	M19
A9	U19
A10	Z19
A11	L17
A12	B19
A13	H19
A14	N19
A15	V19
A16	B21
A17	Q13
B1	N17
B2	Q17
B3	S17
B4	T17
B5	B17
B6	C19
B7	J19
B8	Q19
B9	W19
B10	B20
B11	U17
B12	D19
B13	K19
B14	S19
B15	X19
B16	E21
E18	G18
F18	J18
F19	S20
G18	T29
H17	Q14
J18	T27
L1	U4
L16	M16
M1	V3
M16	Q10
M18	U27
N1	U2
N16	P16
N18	Z25

WIRING TABLE	
PIN NO.	
FROM	TO
P1	U1
P16	Q11
Q12	U15
T15	U15
T33	T34
U27	X24
U29	V28
U33	U34
W27	W29
W33	W34
X24	Z24
X25	X27
Z1	GRD



MI 70083

Figure 3-142. Pb HT-543 10110736 (FG 1500) - schematic.

WIRING TABLE	
FROM	TO
A1	A2
A2	A3
A3	B18
A4	A5
A5	W17
A6	A7
A6	U17
A8	A9
A8	V17
A10	A11
A11	C18
A14	K19
A15	L19
A16	B21
A17	E13
A19	D20
A20	Q19
B2	B7
B2	N17
B3	B6
B3	Q17
B4	B9
B4	T17
B5	B8
B5	S17
B8	B11
B9	B10
B16	C16
B17	D12
B19	E20
B20	D17
B20	X19
C10	C11
C10	Z17
C17	M13
C19	F20
C20	Y19
D16	D17
D17	E34
E2	E12
E12	E13
E17	Q12
E21	F16
E24	X24
F17	H19
G18	Q11
H17	Q16
H19	Q24
J2	J3
J3	J10
J10	J11
J11	J17
J16	X24
K17	L17
L10	X3
L14	U4
L16	M16
L16	Q10
L17	M17
M2	M13
M10	T4
M14	U3

WIRING TABLE	
FROM	TO
M17	Q8
M19	U30
N1	N2
N	U2
N2	N3
N3	N6
N4	N5
N4	T2
N6	N7
N7	N8
N8	N9
N9	N10
N10	N11
N11	N14
N14	N15
N16	P16
N16	Q9
N19	Q16
P1	P2
P1	V1
P2	P3
P3	P6
P4	P5
P5	X1
P6	P7
P7	P8
P8	P9
P9	F10
P10	P11
P14	P15
P14	U1
P24	V29
Q3	X10
Q4	V11
Q5	W16
Q6	Y19
Q7	U19
Q13	T15
Q19	T19
T19	U19
T28	V28
T33	T34
U27	V27
U33	U34
V30	W27
V31	V32
V33	V34
W29	X27
W33	W34
X27	Y24
X30	Y27
X33	X34
Z1	GRD

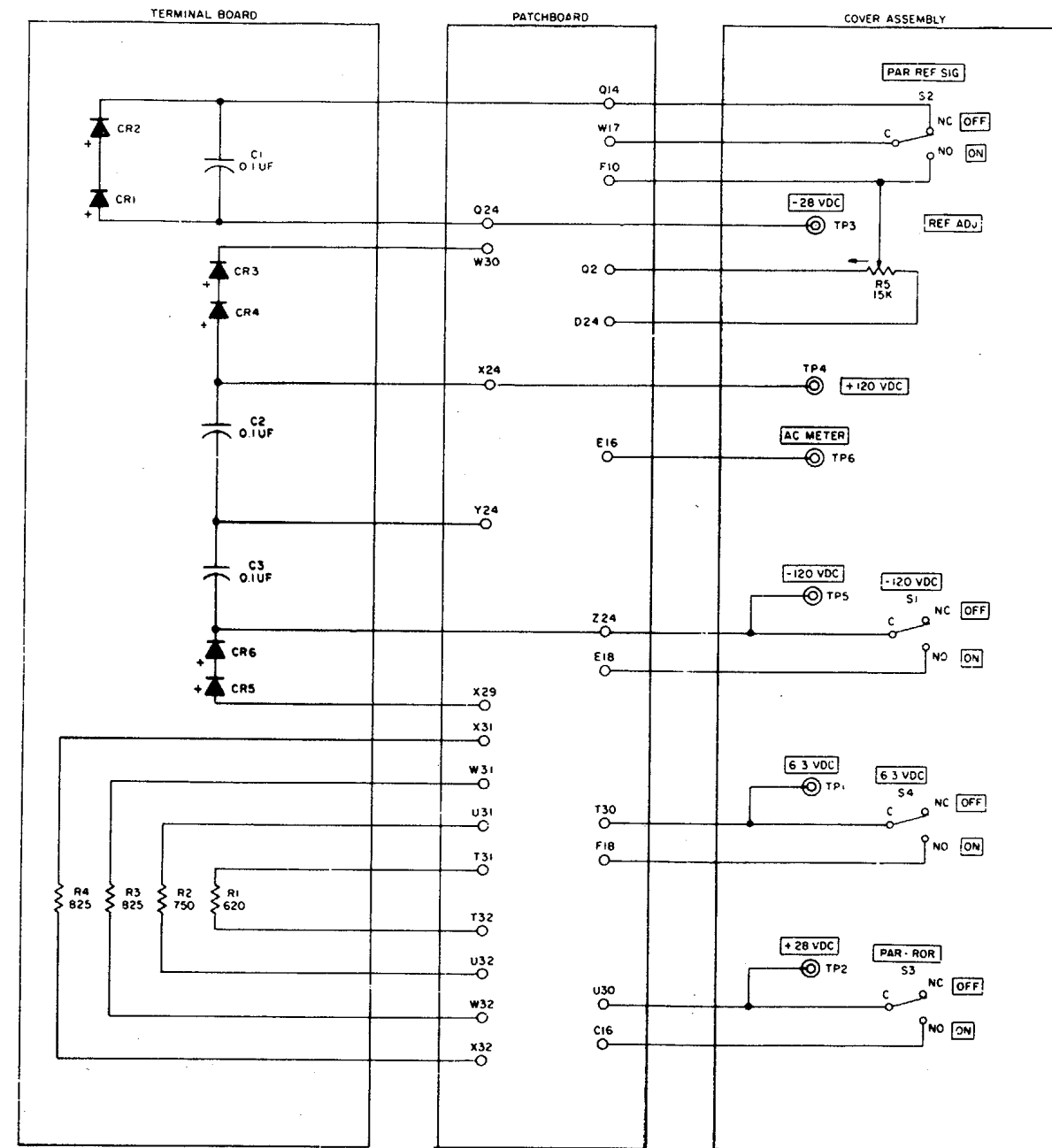

MI 70084

Figure 3-129. Pb HT-544 10112776 (FG 1505) - schematic.

WIRING TABLE	
FROM	TO
A1	U19
A2	S19
A16	U25
A19	Q24
B19	C19
C9	Q11
E19	T29
F19	T27
H19	U29
J31	R30
K19	Y30
K32	Q34
K33	P34
K34	N34
L3	R7
L4	M2
L4	X7
L16	M16
L19	Z23
M1	M2
M3	Y16
M5	N3
M16	Q13
N1	N2
N2	N4
N3	U9

WIRING TABLE	
FROM	TO
N4	X9
N16	P16
P1	P2
P2	P3
P3	P5
P4	P5
P5	U10
P16	Q14
P24	S25
Q14	T15
R30	S26
S26	U27
S27	S28
S29	S30
T15	U15
T33	T34
U27	V27
U33	U34
V25	W25
V28	V29
V30	X23
V31	V32
V33	V34
X27	Y29
Y33	Y34
Z1	GRD

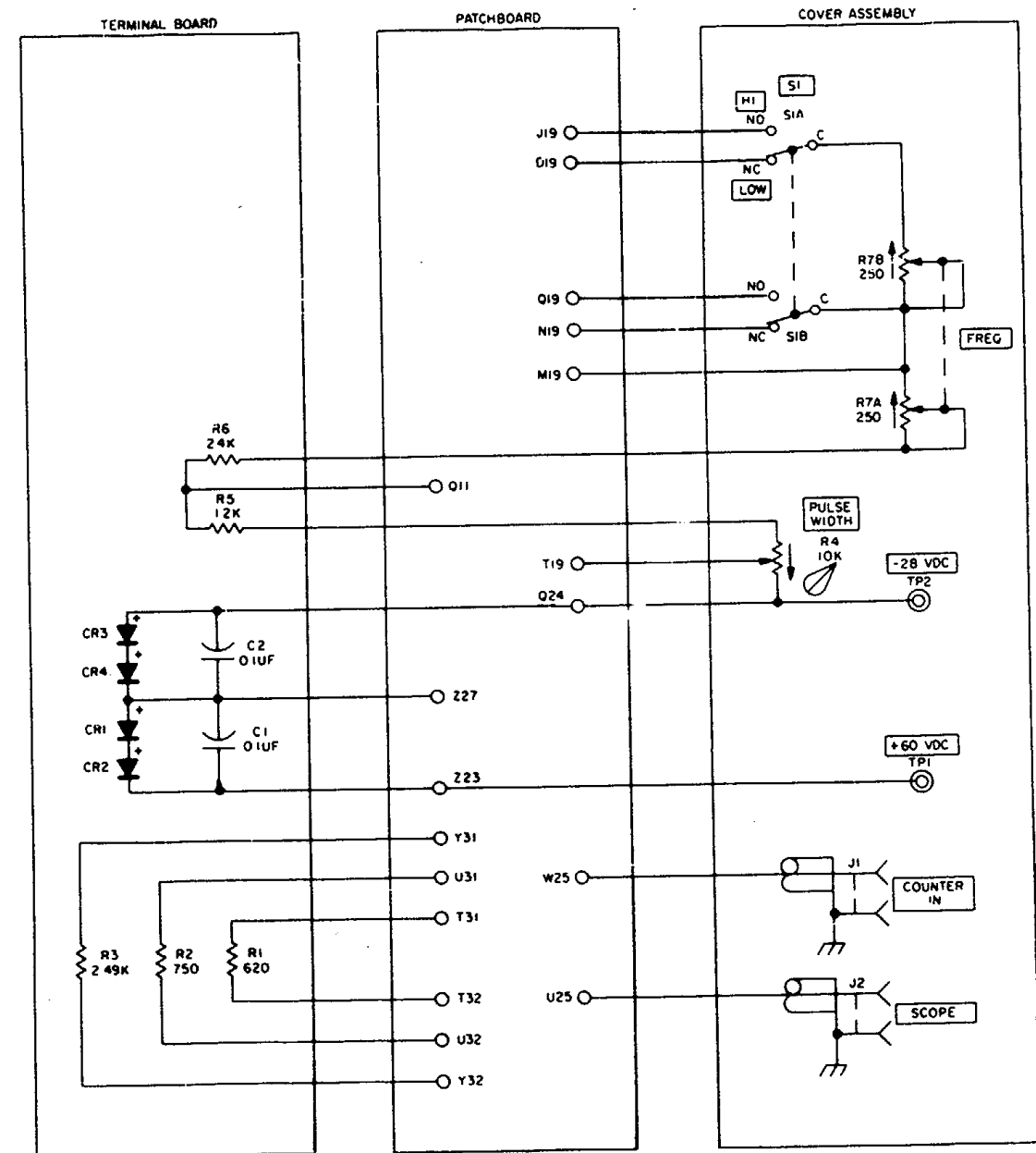

MI 70085

Figure 3-144. Pb HT-545A 10111855 (FG 1510) - schematic.

WIRING TABLE	
FROM	TO
A1	A2
A2	A3
A3	A4
A4	A5
A5	A6
A6	B18
A8	A9
A9	A12
A12	J19
A16	Q16
A18	G7
A19	P24
B2	B3
B3	B4
B4	B5
B5	B6
B6	B17
B16	C16
B18	C17
B19	C19
C3	C4
C4	C5
C5	C6
C6	F17
C16	D16
C17	H17
C19	M19
D4	D5
D4	L17
D5	D6
D16	E16
D18	E18
D18	Q13
D19	P11
D19	R23
E5	E6
E6	S17
E16	F16
E18	Q14
E19	M18
F6	W17
F16	G16
F18	K19
F19	Q18
G16	H16
G18	L19
G18	Z23
H8	H11
H9	H10
H16	H19
H17	M17
H19	J18
J18	U29
J19	T19
K18	Z24
K19	Y30
L18	Q12
M8	U10
M12	V10
M16	Q8
M17	T17

WIRING TABLE	
FROM	TO
M18	T29
M19	Q10
N8	X11
N12	W11
N16	Q9
N19	P13
N33	P34
P8	P9
P8	S19
P9	P10
P12	P13
P16	U25
P24	X18
Q1	V1
Q2	T2
Q6	X7
Q7	X9
Q12	T15
Q18	T27
Q24	S25
S23	U29
S26	V27
S27	S28
S29	S30
T15	U15
T17	X17
T33	T34
U27	V28
U33	U34
V27	X30
V28	V29
V28	W29
V30	Y23
V33	V34
W27	Y29
W33	W34
X33	X34
Y27	Z27
Y33	Y34
Z1	GRD

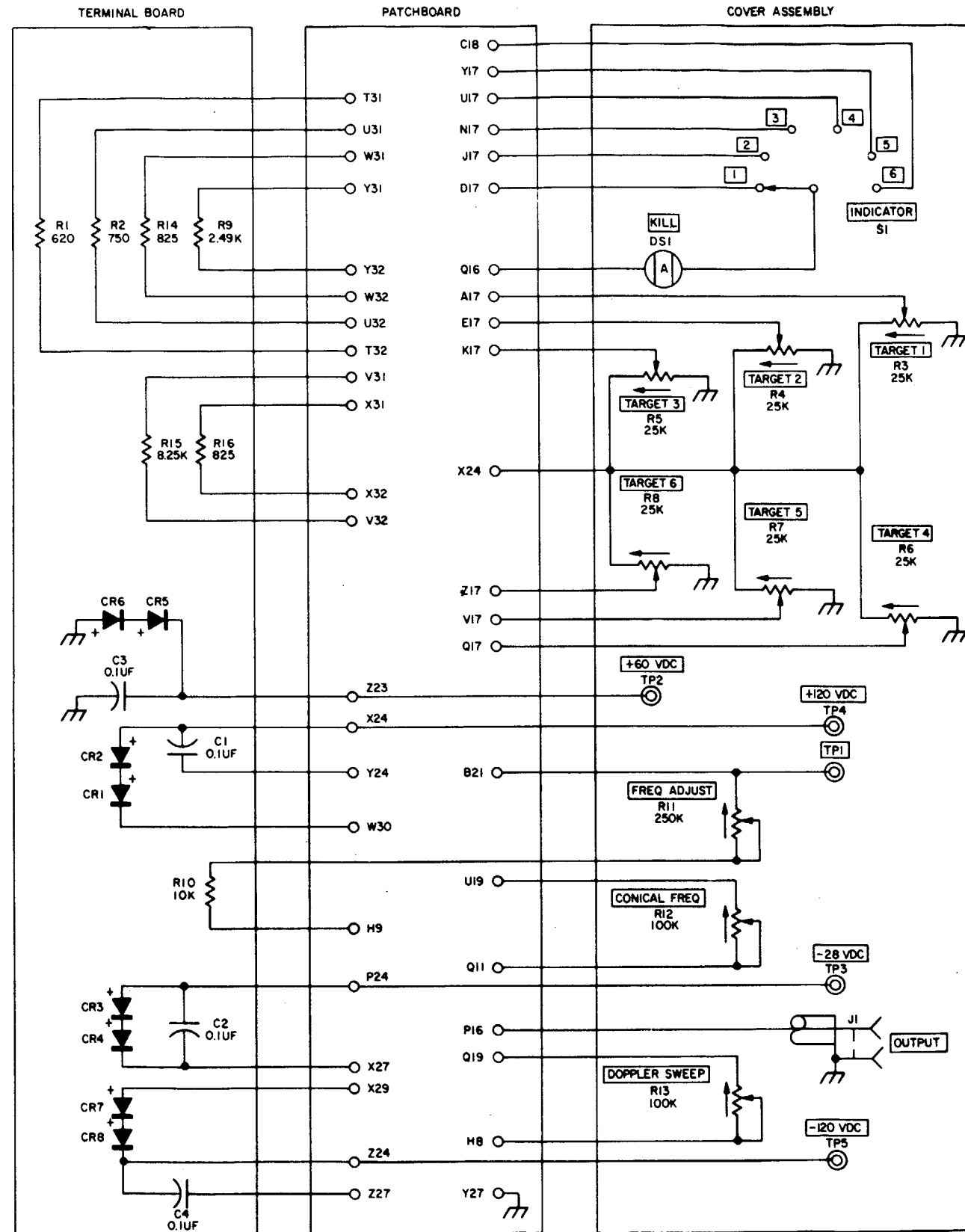

MI 70086

Figure 3-145. Pb HT-547B 10173898 (FG 1515) - schematic.

WIRING TABLE	
PIN NO.	
FROM	TO
A5	W17
A16	B21
A18	A20
B17	Y30
B20	H20
C17	E19
C18	T17
C18	T27
C23	Q23
C25	Y27
D18	T29
D25	Q17
E19	Z24
E25	Q16
F19	U29
G17	G19
G34	J20
H18	K18
H20	K20
Q30	R31
Q30	X30
J18	J20
K18	N17
K20	N19
K32	Q34
K33	P34
K34	N34
L1	V1
L5	X1
L16	M16
M1	M5
M1	T2
M16	Q11
N1	U11
N2	N6
N5	U11
N6	N7
N7	V11
N16	N17
N16	P16

WIRING TABLE	
PIN NO.	
FROM	TO
N19	Q14
P1	P5
P2	S10
P5	V10
P6	T10
P7	W10
P16	Q12
P17	P19
P23	Y23
Q10	S17
Q13	T15
Q18	Q20
Q20	Y19
Q23	X23
S25	T23
S26	V27
S27	S28
S29	S30
T15	U15
T27	X24
T33	T34
U15	W16
U23	X20
U28	V28
U33	U34
V18	V20
V20	Y24
W19	Y23
W27	W29
W33	W34
X17	X19
X23	Z23
X27	X30
X33	X34
Y17	Y19
Y24	Z27
Y29	Z27
Y33	Y34
Z1	GRD
Z19	Z23

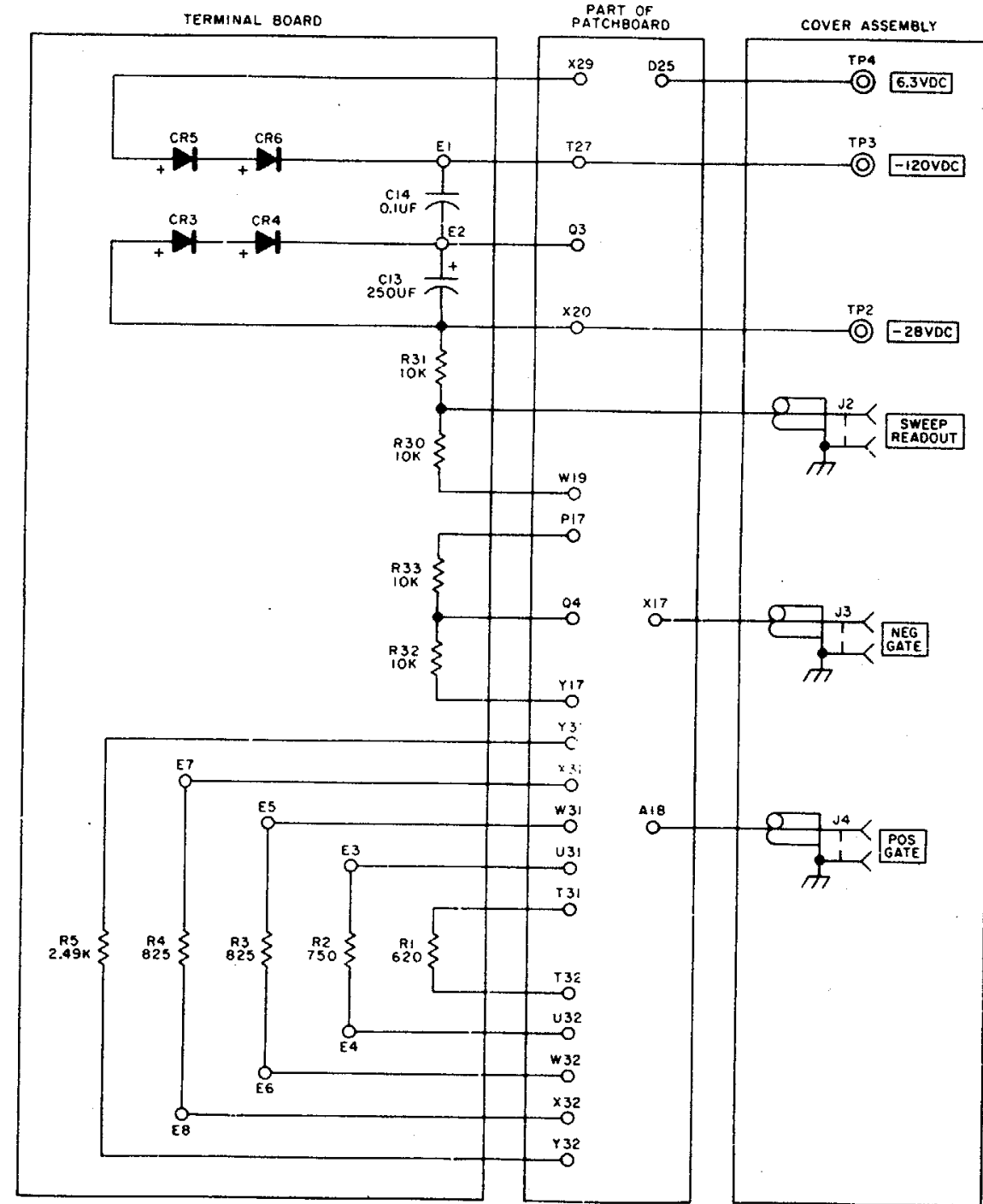

MI 70087

Figure 3-146. Pb HT-548A 10111378 (FG 1520) - schematic (sheet 1 of 2).

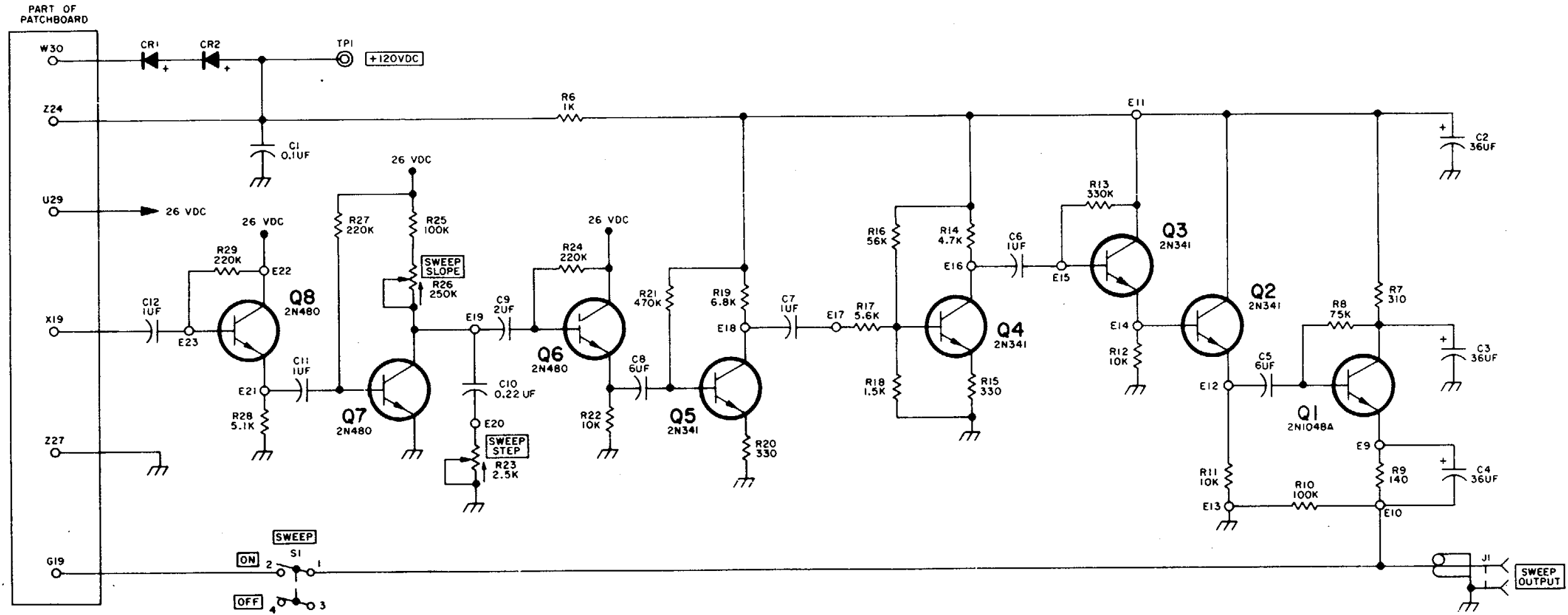

MI 70088

Figure 3-146. Pb HT-548A 10111378 (FG 1520) - schematic (sheet 2 of 2).

WIRING TABLE	
PIN NO	
FROM	TO
A17	D17
A17	T27
G17	F:7
D17	E:7
F17	T30
F21	L16
F22	Q13
J31	M2
K32	Q34
K33	R34
K34	N34
M2	M3
M4	M5
M5	M31
M16	Q14
M17	Y30
M30	T27
N1	V11
N2	T11
N3	S11
N4	N5
N5	U11
N16	Q10
N33	P34
P1	P2
P2	P4
P2	T10
P3	P5
P3	R10
P16	Q11
Q2	S2
Q3	U3
Q4	U4
Q6	R6
Q7	X7
Q9	X9
Q14	T15
T15	U15
T27	V27
T33	T24
U30	V28
U33	U34
V28	W29
W33	W34
Y24	Y27
Y27	Y29
Y33	Y34
Z1	GRD

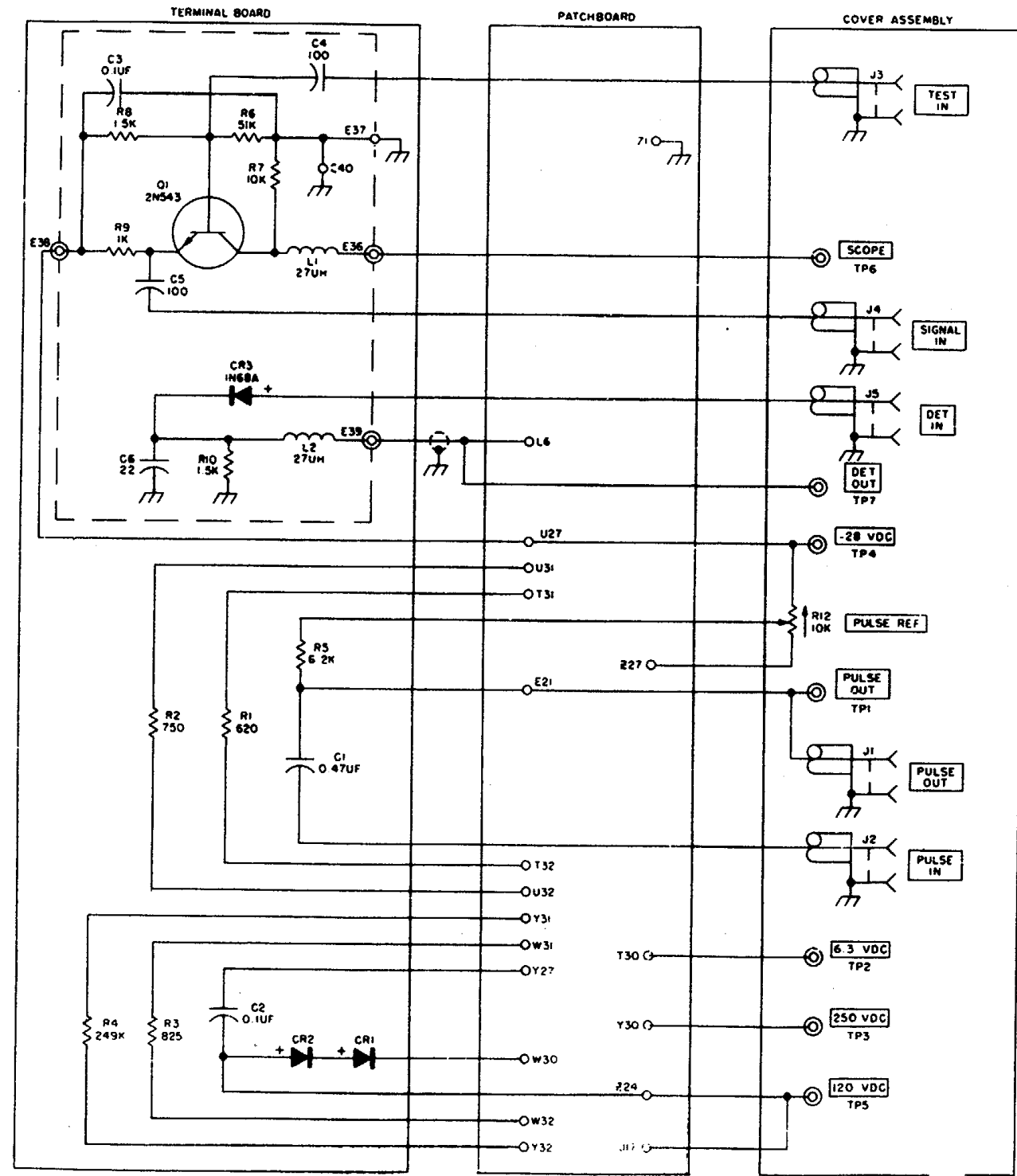

MI 70089

Figure 3-147. Pb HT-550A 1017936 (FG 1525) - schematic.

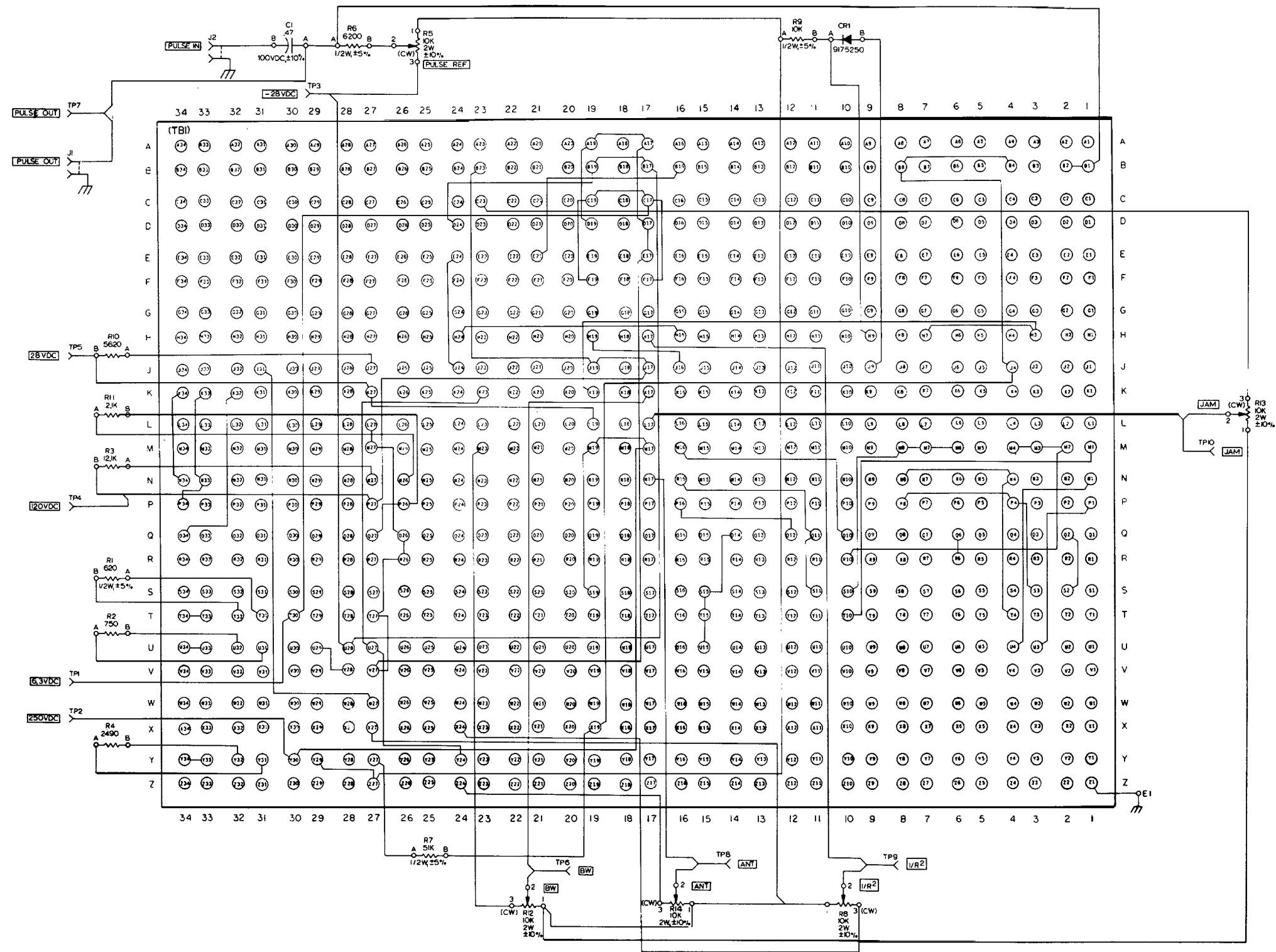

MI 70091

Figure 3-148. Pb HT-551B 10677208 (FG 1530) - schematic.

WIRING TABLE		WIRING TABLE		WIRING TABLE	
PIN NO		PIN NO		PIN NO	
FROM	TO	FROM	TO	FROM	TO
A1	G18	J31	P8	N4	N5
A2	J18	K9	T19	N5	N6
A3	K18	K11	K13	N6	N7
A4	L18	K11	U19	N7	N15
A5	R17	K13	K14	N9	U10
A6	S17	K16	Q16	I19	N10
A7	T17	K19	L19	N11	V12
A8	Q17	K32	Q34	N12	N14
A9	A10	K33	P34	N15	P15
A9	P19	K34	N34	P1	P2
A11	A12	L1	L2	P2	P3
A11	R19	L2	L3	P5	P4
A13	A14	L3	L4	P4	P5
A13	X19	L4	L5	P5	P6
A18	C2	L5	L6	P6	P7
A20	K19	L6	L7	P7	P8
B3	M17	L7	L8	P8	P13
B4	N17	L8	R30	P9	P10
B5	U17	L9	L10	P10	P11
B9	N19	L9	L11	P13	P14
B14	V19	L10	L11	P14	P15
B16	D22	L12	L14	P16	Q12
B17	Z24	L13	S11	P17	Q14
B18	E18	L14	L15	Q3	S3
C16	F21	L16	M16	Q4	W4
C17	P24	L19	M19	Q6	Y6
D1	D18	L31	P9	Q7	R7
D16	F22	M1	Y16	Q9	U9
D17	F17	M2	M3	Q13	U15
D19	G17	M2	U1	Q19	S19
E12	E13	M3	M4	Q23	Y23
E12	J19	M4	M5	Q24	Y30
E13	E14	M5	M6	S19	Y19
E18	H18	M6	M7	T15	U15
E19	U24	M7	M8	U27	V27
G17	U29	M9	M10	U33	U34
H1	H2	M9	M30	V24	V29
H2	H3	M10	M11	V27	W29
H3	H4	M11	M12	V30	W29
H4	H5	M12	M13	V31	V32
H5	H6	M13	M14	V33	V34
H6	H7	M14	M15	W33	W34
H7	H8	M16	Q11	Y24	Z23
H8	P24	M19	Q19	Y24	Z27
H16	X24	N1	N2	Y29	Z27
H18	L19	N1	V10	Y31	Y32
H18	P17	N2	N3	Y33	Y34
J14	W19	N3	N4	Z1	GRD
J16	K16				

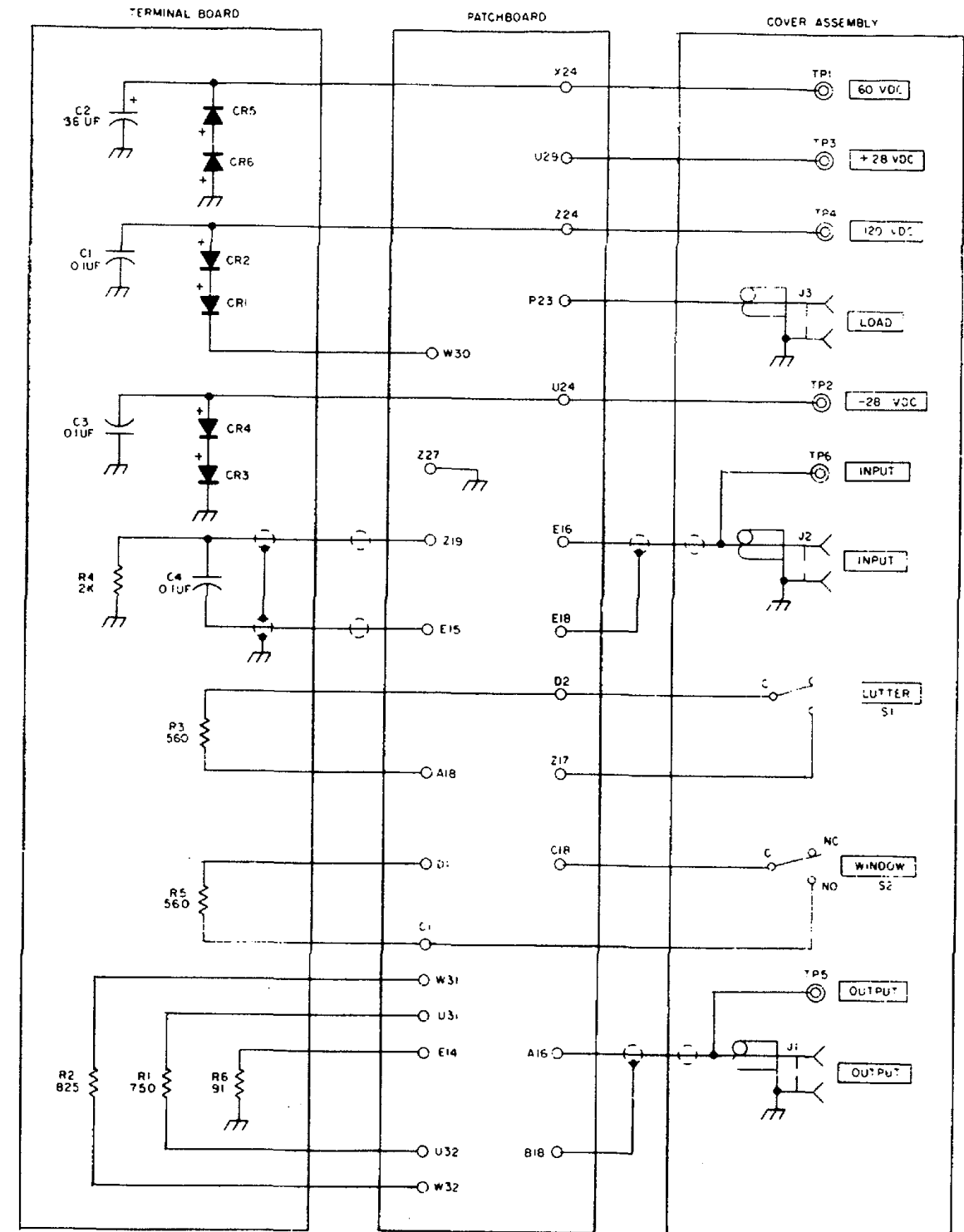

↓ SHIELDED TO P17
 ↓ SHIELDED TO Q19
 ↓ SHIELDED TO S19
 ↓ SHIELDED TO Y19



MI 70092

Figure 3-149. Pb HT-556A 10112786 (FG 1545) - schematic.

WIRING TABLE		WIRING TABLE		WIRING TABLE	
FROM	TO	FROM	TO	FROM	TO
A7	Z17	F8	F9	M17	N17
A8	V17	F9	F10	M23	P24
A9	A10	F16	F17	M30	P14
A10	X17	F19	G13	N1	N7
A18	H17	G1	G3	N7	U10
A19	B19	G3	G4	N8	N9
B11	H19	G4	G5	N8	V10
B12	P19	G5	G6	N9	N10
B13	B14	G11	G12	N11	N12
B14	Z19	G12	G13	N11	X1
B16	B21	G16	Z24	N13	V1
B17	G6	G17	U23	N14	T1
B19	F19	G19	R19	N16	P16
C1	C2	H1	H2	N17	Q11
C2	C3	H2	H3	N17	U17
C3	C4	H3	H4	P1	V11
C4	C5	H4	H5	P2	P3
C5	C6	H5	K17	P3	P4
C6	L17	H17	M17	P3	V3
C11	W19	H30	L10	P4	P5
C12	Q19	J17	K9	P5	P6
C13	T19	J30	L7	P6	P11
C16	E21	K7	K8	P7	Y16
C17	F10	K8	K9	P9	S11
D1	D2	K10	T17	P10	U11
D2	D3	K32	Q34	P12	P13
D3	D5	K33	P34	P12	W3
D5	D6	K34	N34	P16	Q13
D6	D7	L1	L2	Q4	R7
D7	D8	L2	L3	Q4	T4
D8	D9	L3	L4	Q11	U9
D9	D10	L4	L5	Q14	T15
D10	D17	L5	L6	Q24	Z19
D13	E14	L6	L10	R19	U19
D16	U30	L7	L8	S25	T24
E1	E2	L8	L9	S26	U28
E2	E3	L14	M31	S27	S28
E3	E4	L16	M16	S29	S30
E4	E6	M1	M2	T15	U15
E6	E7	M2	M3	T23	V30
E7	E8	M3	M4	U15	W16
E8	E9	M4	M5	U17	W17
E9	E10	M5	M6	U19	Y19
E10	E17	M6	M10	U28	V28
E14	L23	M7	M8	U33	U34
E16	E19	M8	M9	V28	V29
E16	U24	M9	M10	V31	V32
F1	F2	M10	M10	V33	V34
F2	F4	M11	M12	W17	X17
F4	F5	M11	T2	W27	W29
F5	F6	M12	M13	W33	W34
F6	F7	M14	U2	X19	Y19
F7	F8	M16	Q12	Y24	Z27
		Z1	GRD		

 SHIELD TO H17
 SHIELD TO U17

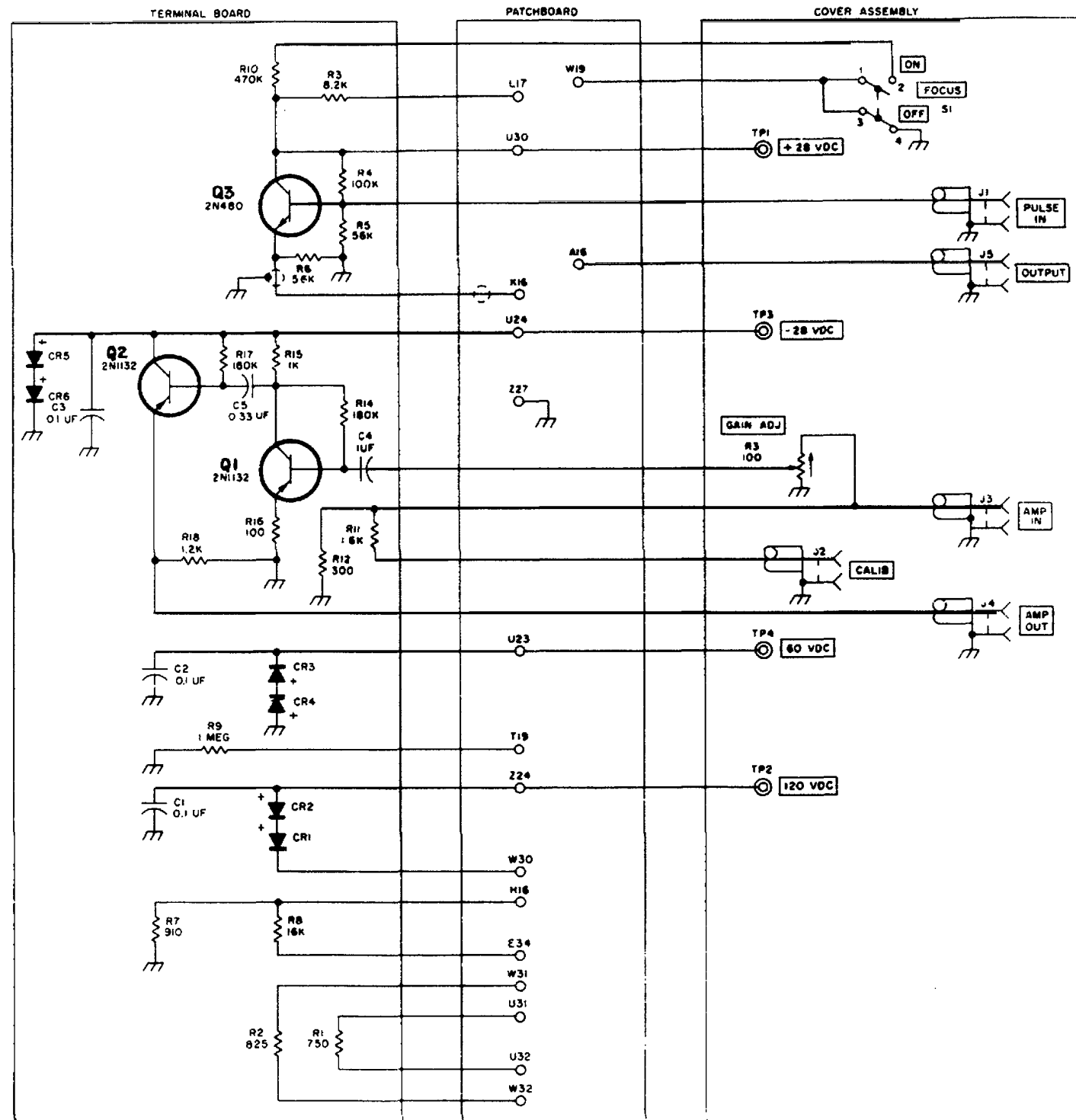

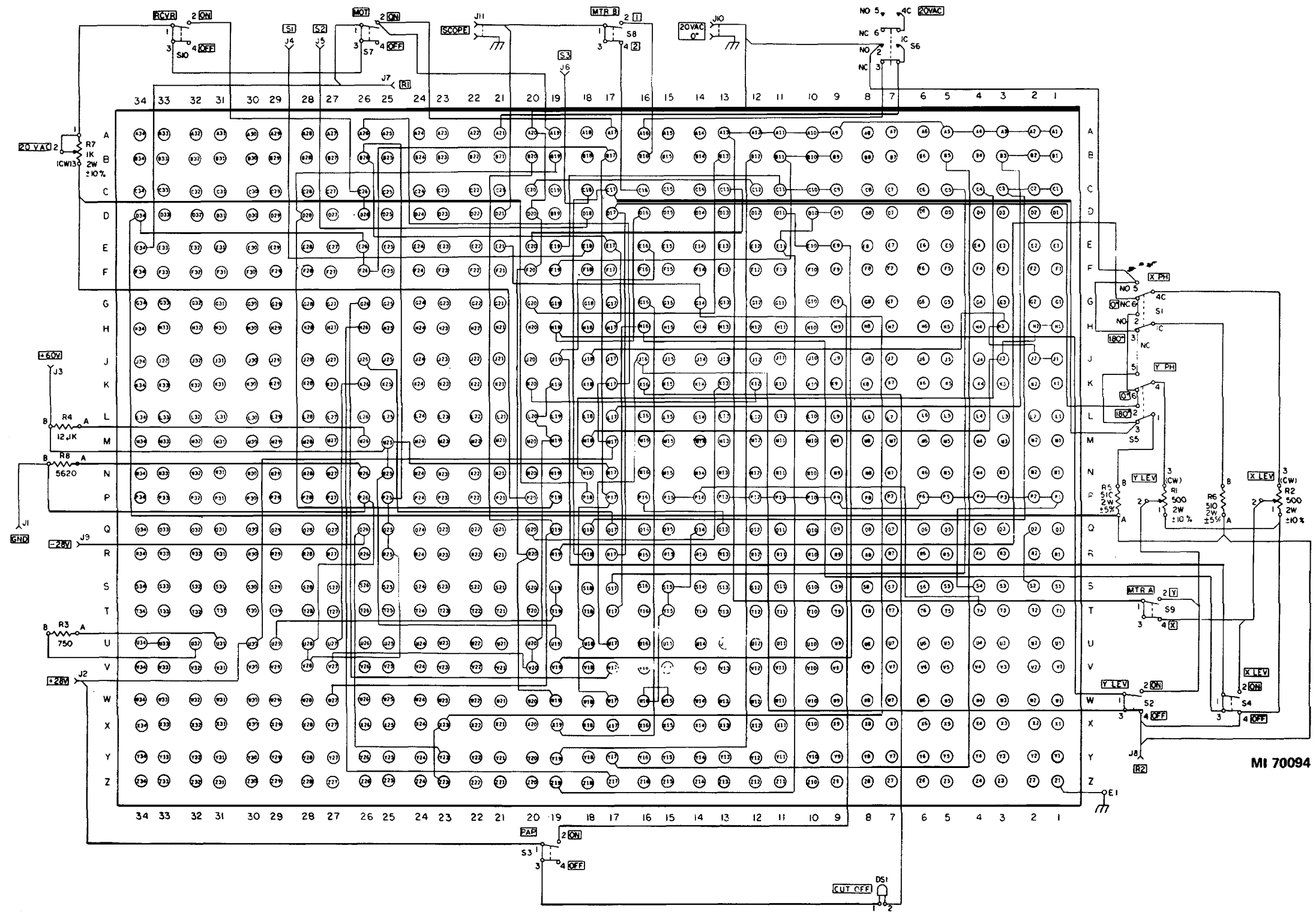

MI 70094

MS 309271

Figure 3-151. Pb HT8-101 10670266 (FG 1830) - schematic.

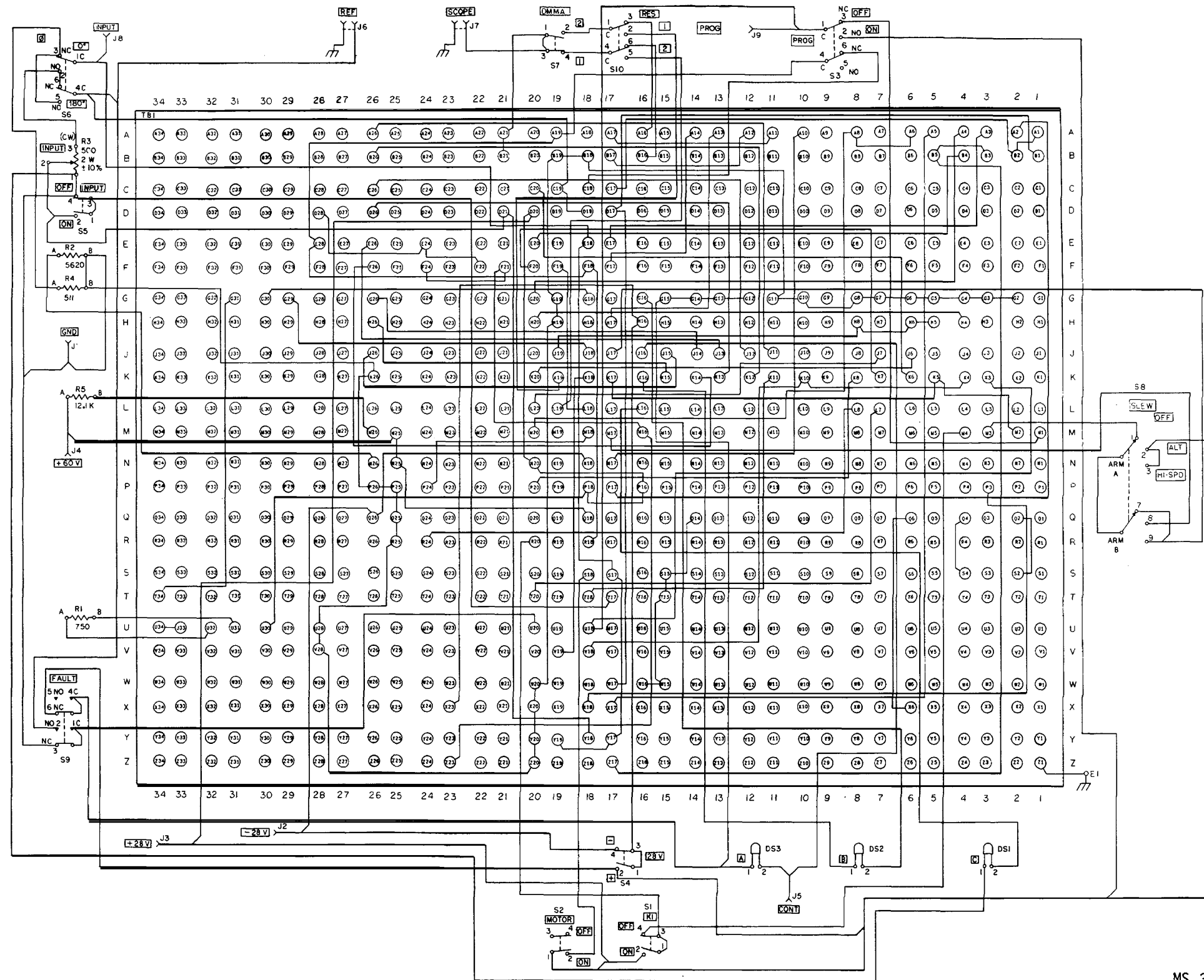

MS 309272

Figure 3-152. Pb HT8-104A 11566561 (FG 3870) - schematic.

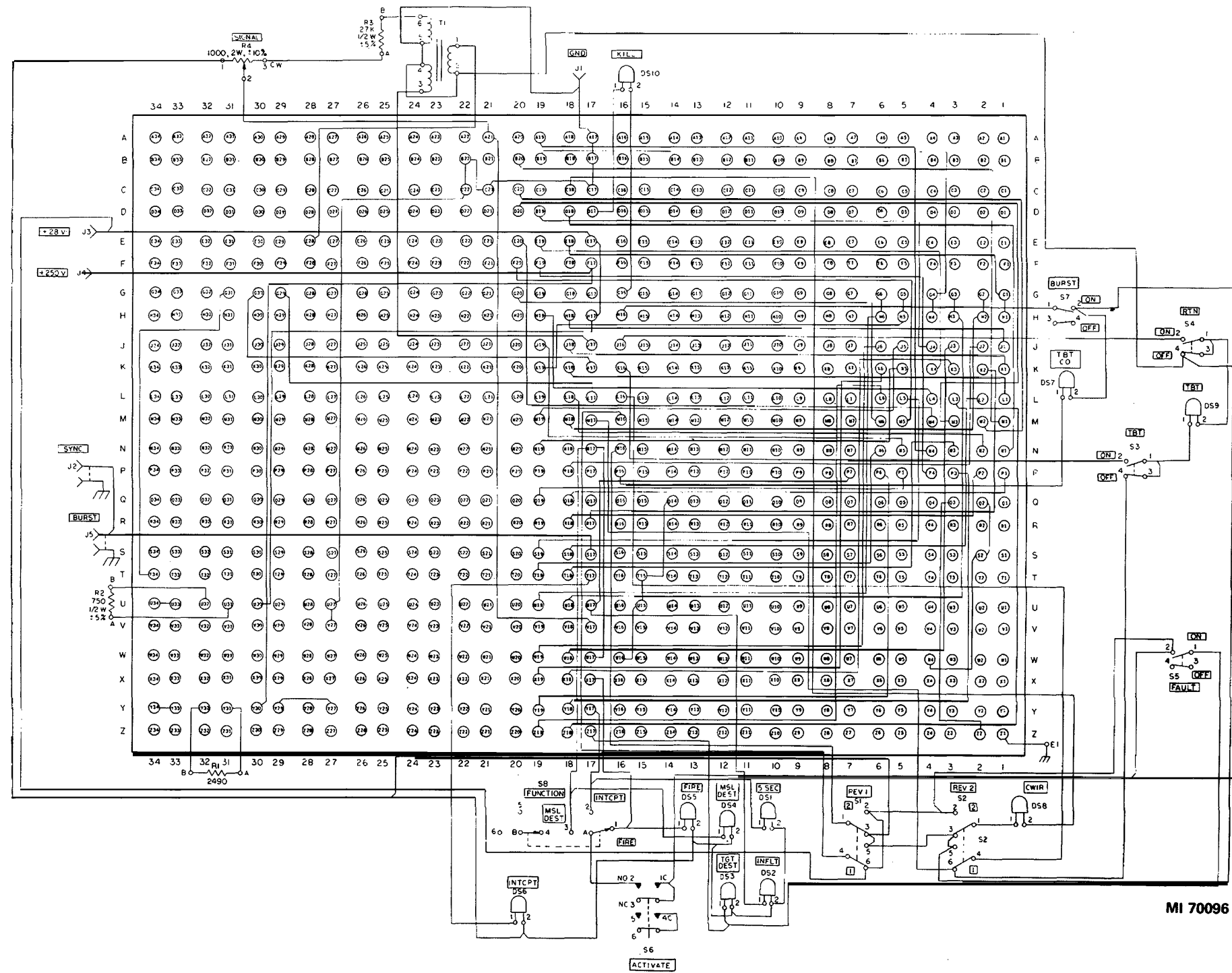

Figure 3-153. Pb HT8-105 10671256 (FG 1840) - schematic.

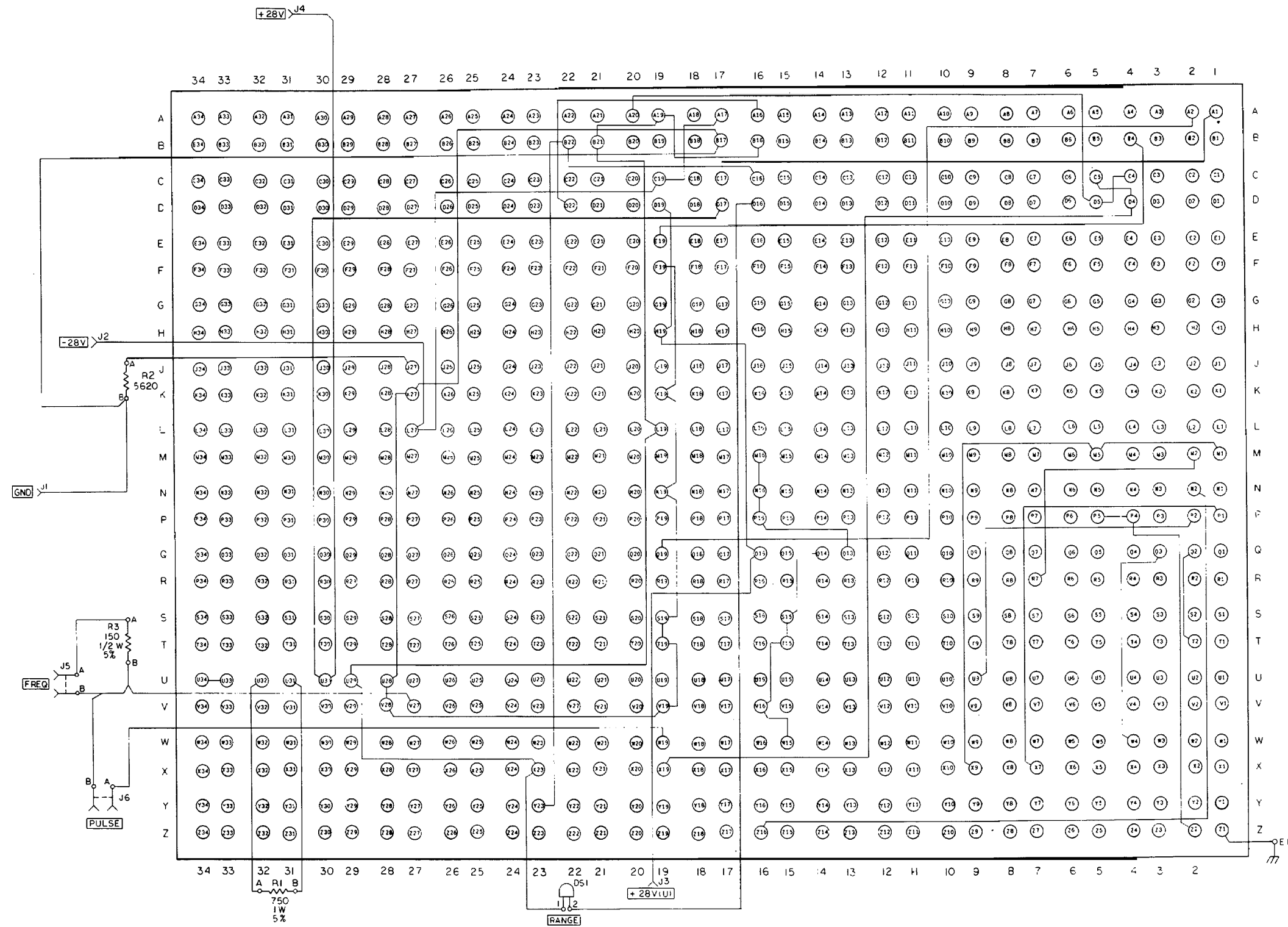
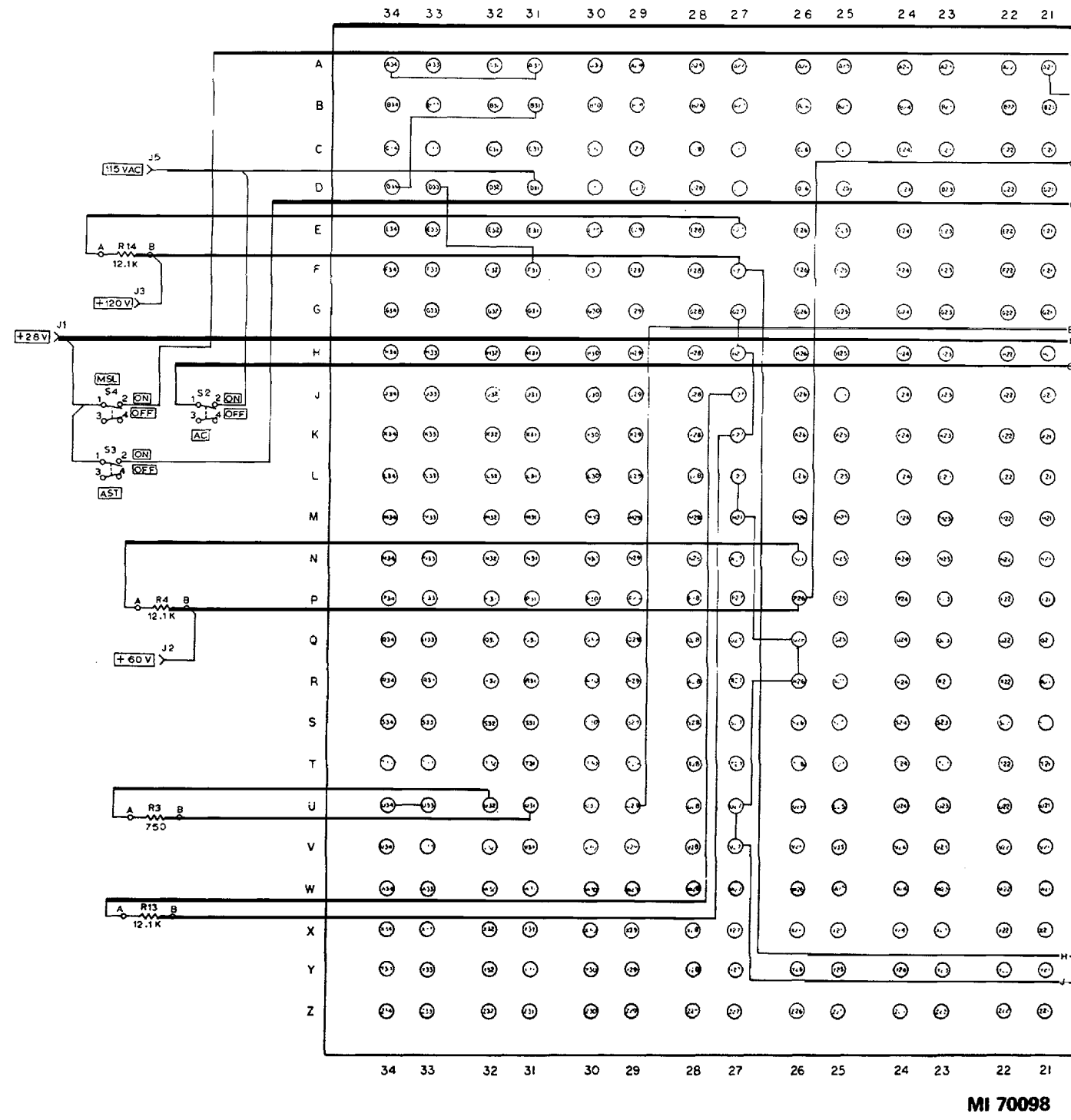

Figure 3-154. Pb HT8-107 10671617 (FG 1845) - schematic.



MI 70098

SEE SHEET 2

Figure 3-155. Pb HT8-109 10670291 (FG 3880) - schematic (sheet 1 of 2).

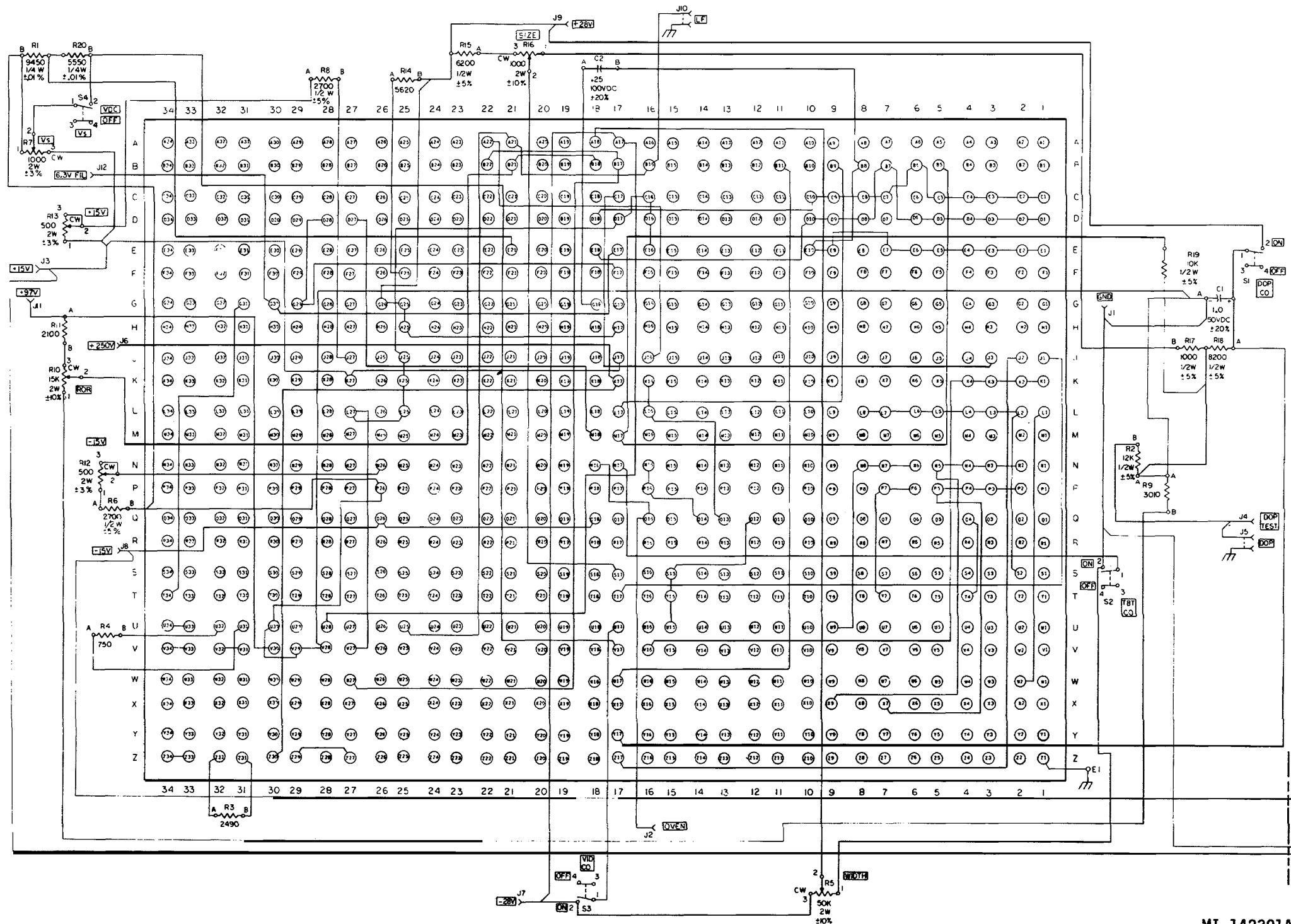

MI 142391A

SEE SHEET 2

Figure 3-156. Pb HT8-1010A 10288432 (FG 1860) - schematic (sheet 1 of 2).

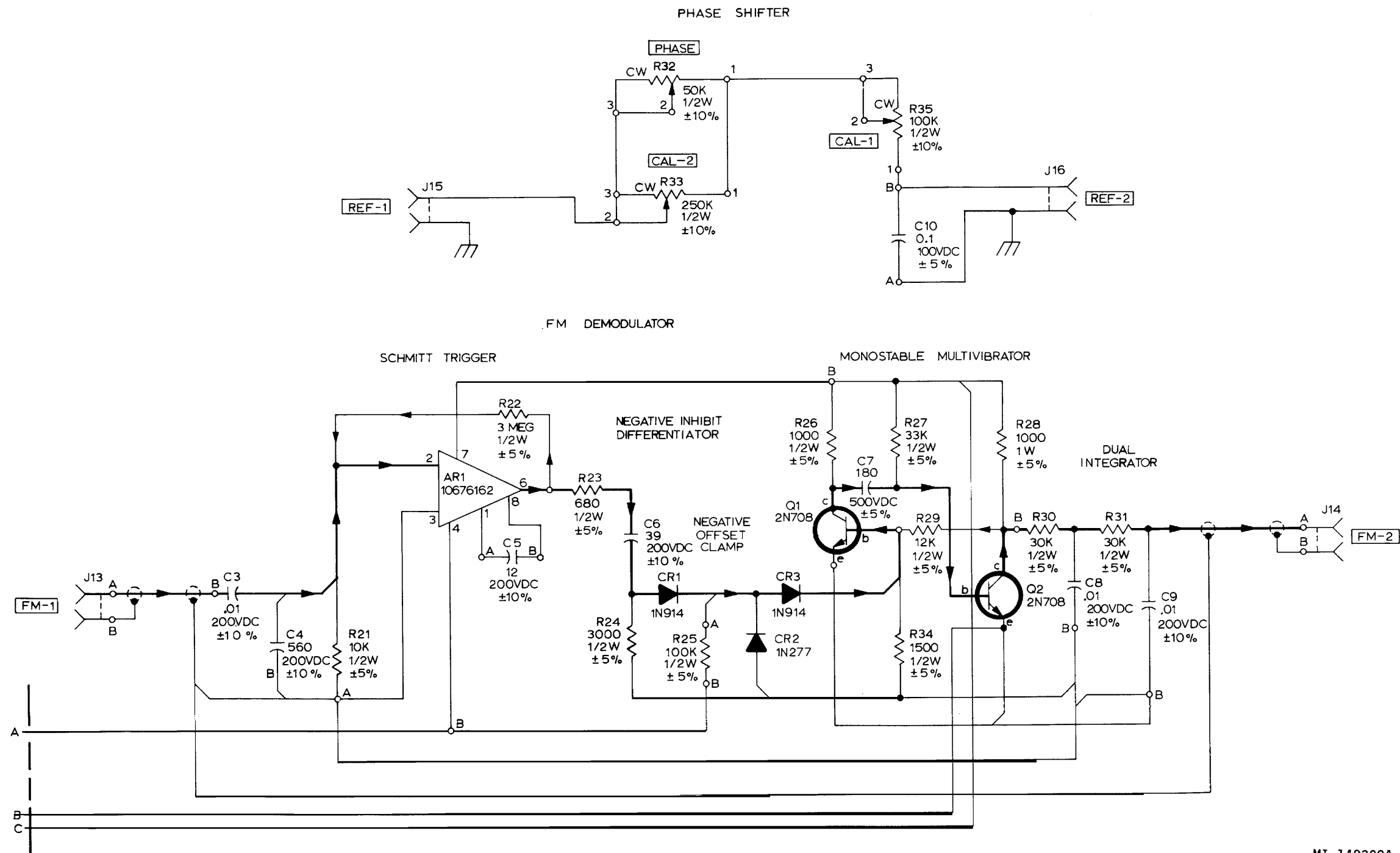

MI 142392A

SEE SHEET 1

Figure 3-156. Pb HT8-1010A 10288432 (FG 1860) - schematic (sheet 2 of 2).

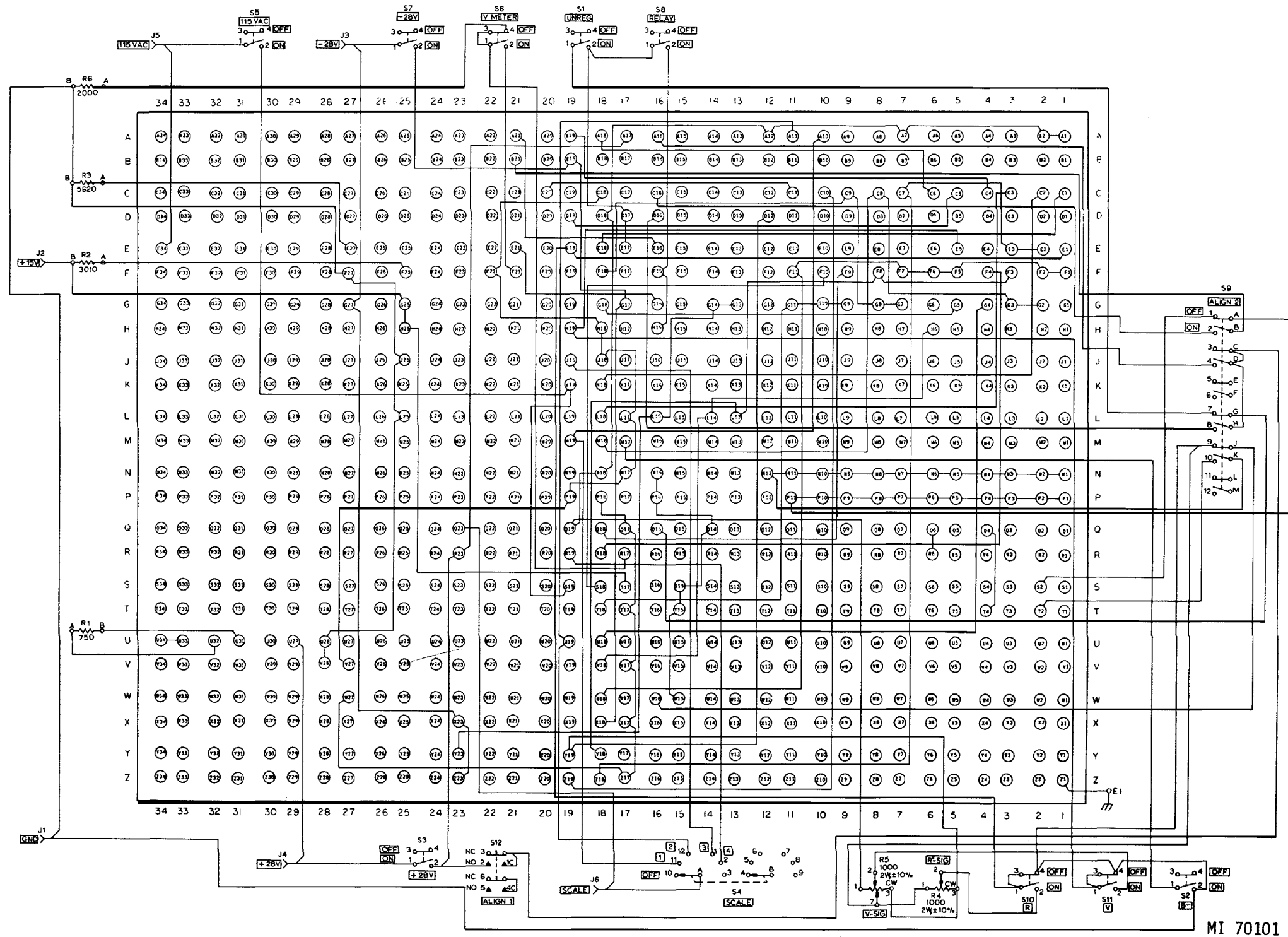

Figure 3-157. Pb HT8-1011 10671750 (FG 1865) - schematic.

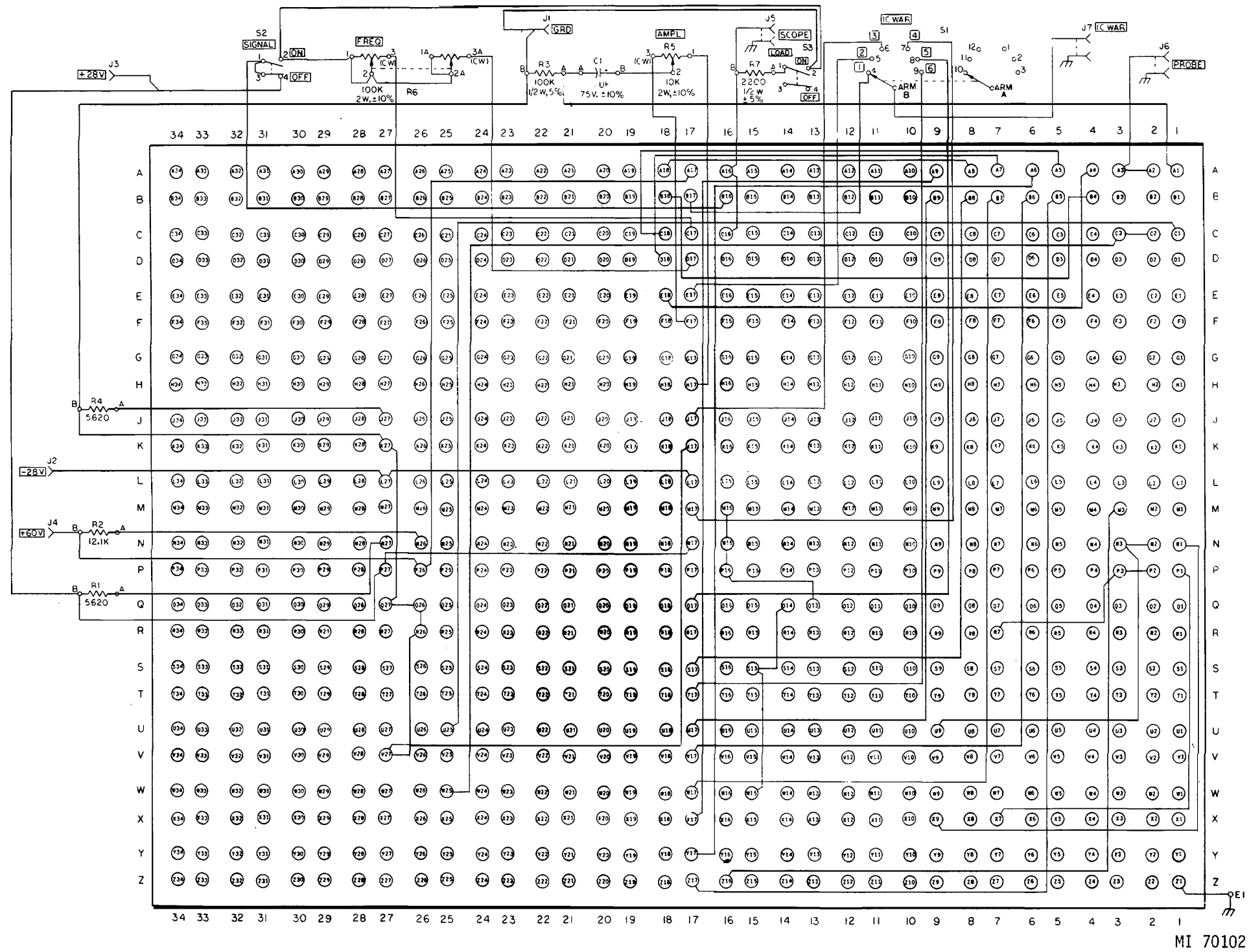

Figure 3-158. Pb HT8-1012 10671751 FG 1870) - schematic.

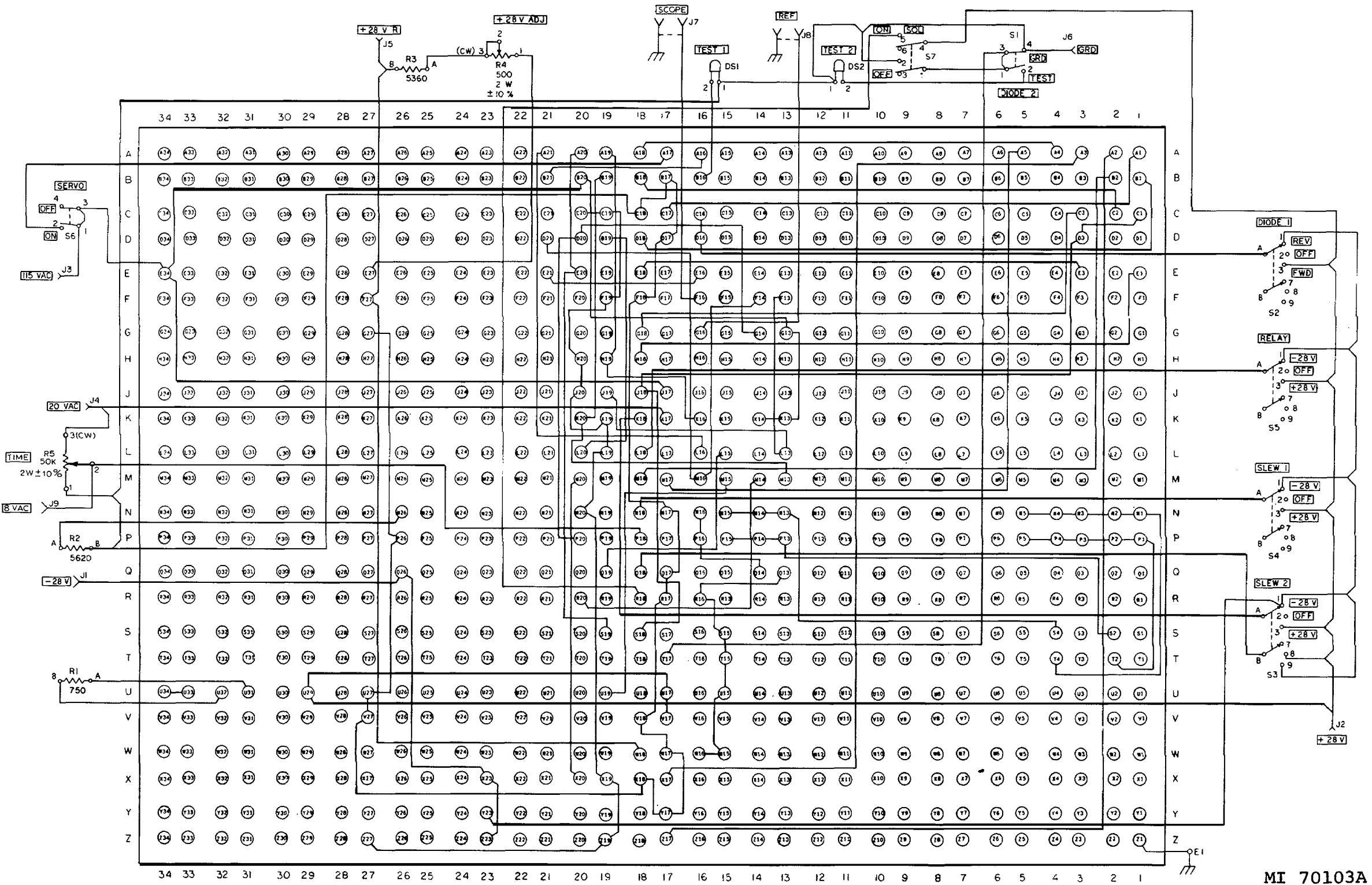
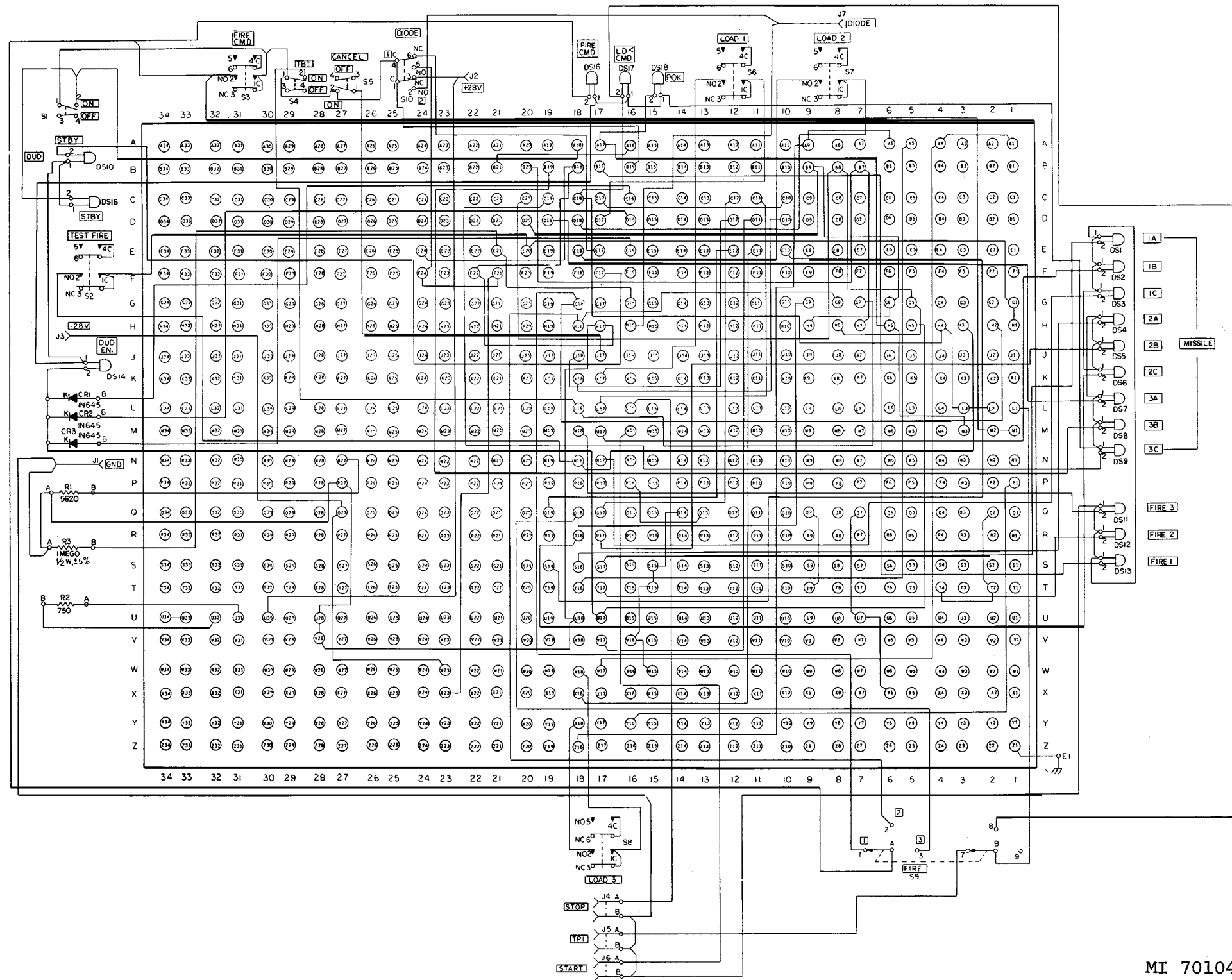
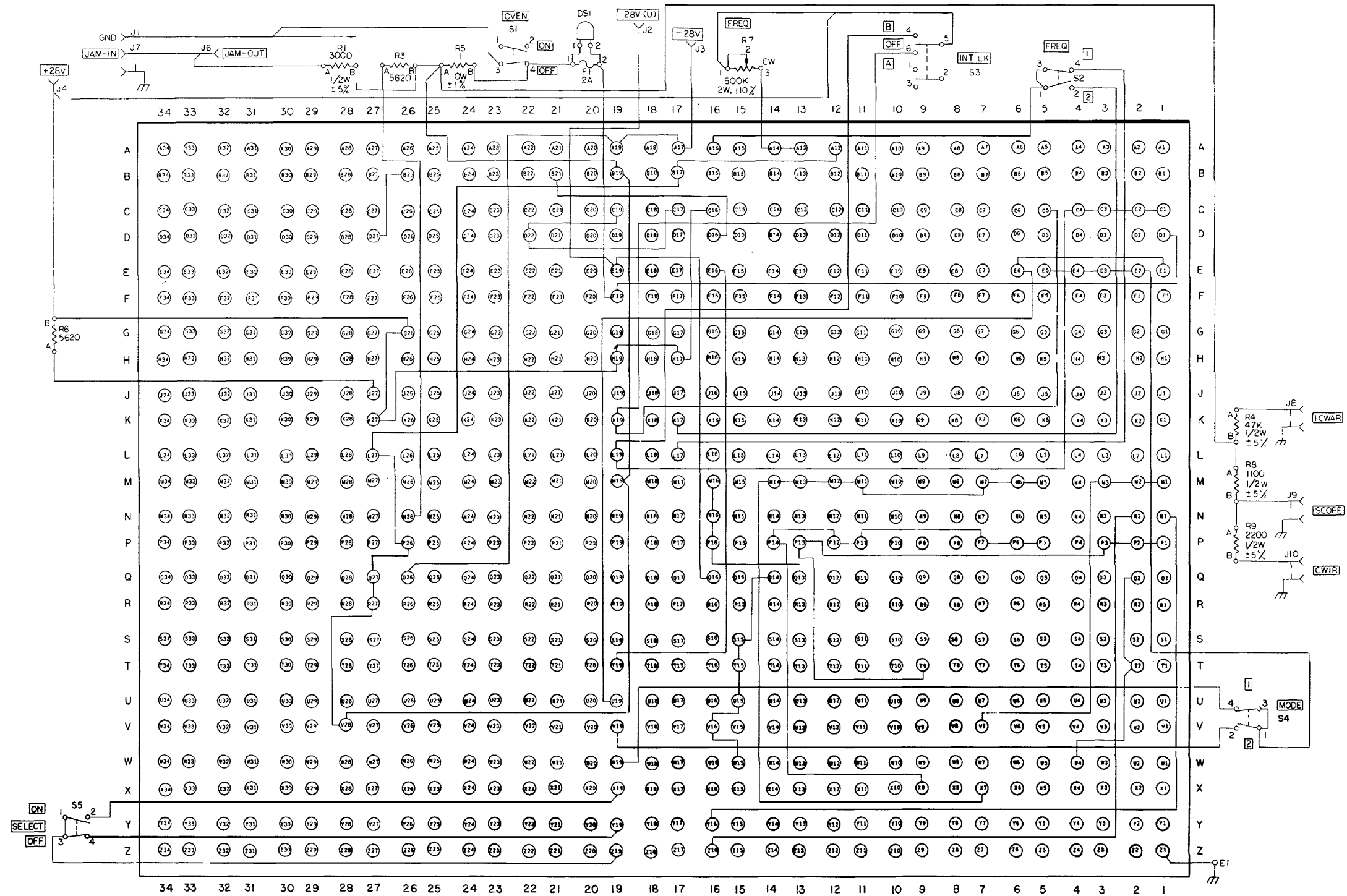

Figure 3-159. Pb HT8-1013 10670287 (FG 3890) - schematic.



MI 70104

Figure 3-160. Pb HT8-1015 10671543 (FG 1880) - schematic.



MI 70106B

Figure 3-161. Pb HT8-1016 10671613 (FG 1885) - schematic.

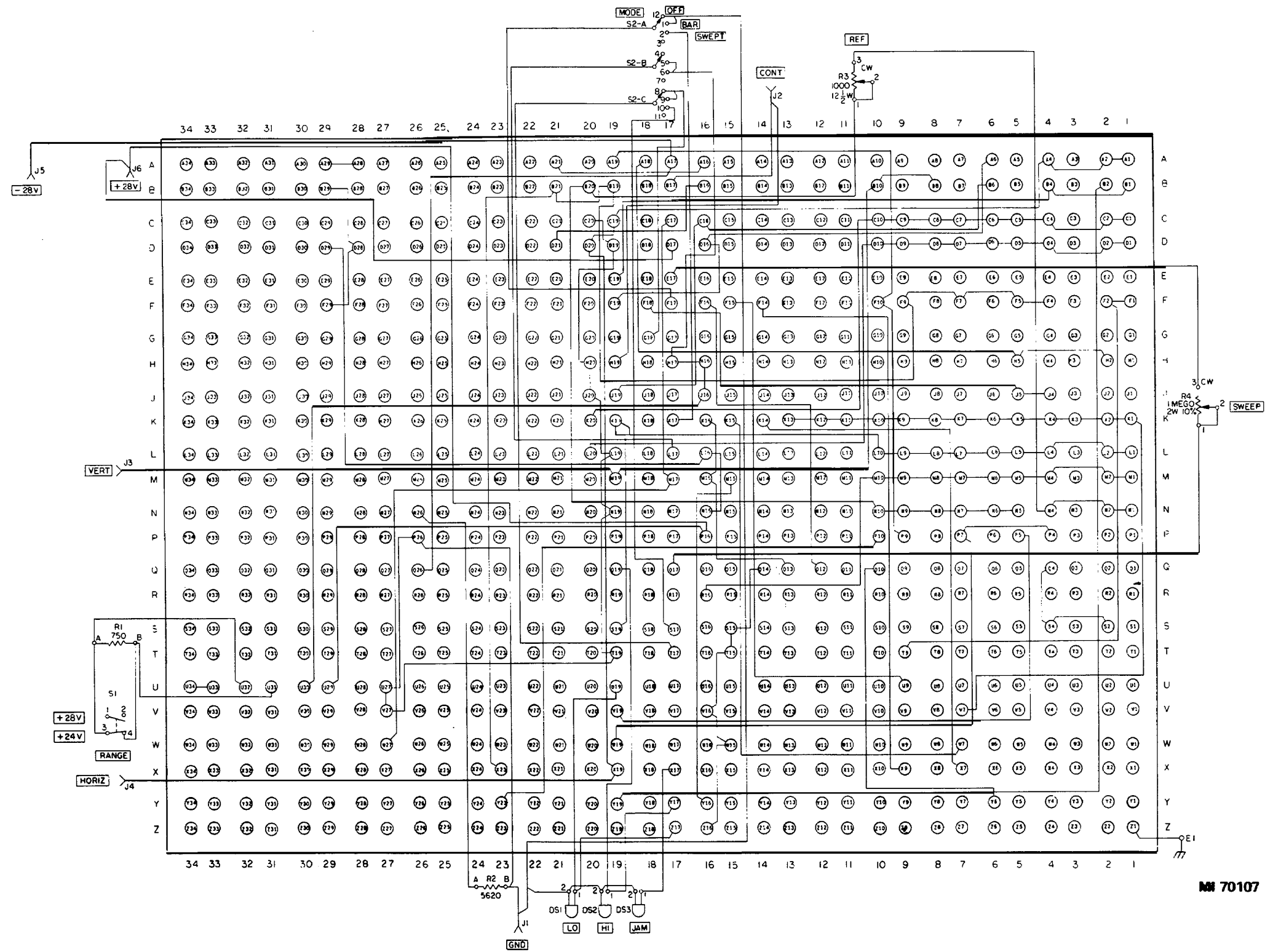

MM 70107

Figure 3-162. Pb HT8-1012 10670916 (FG 1895) - schematic.

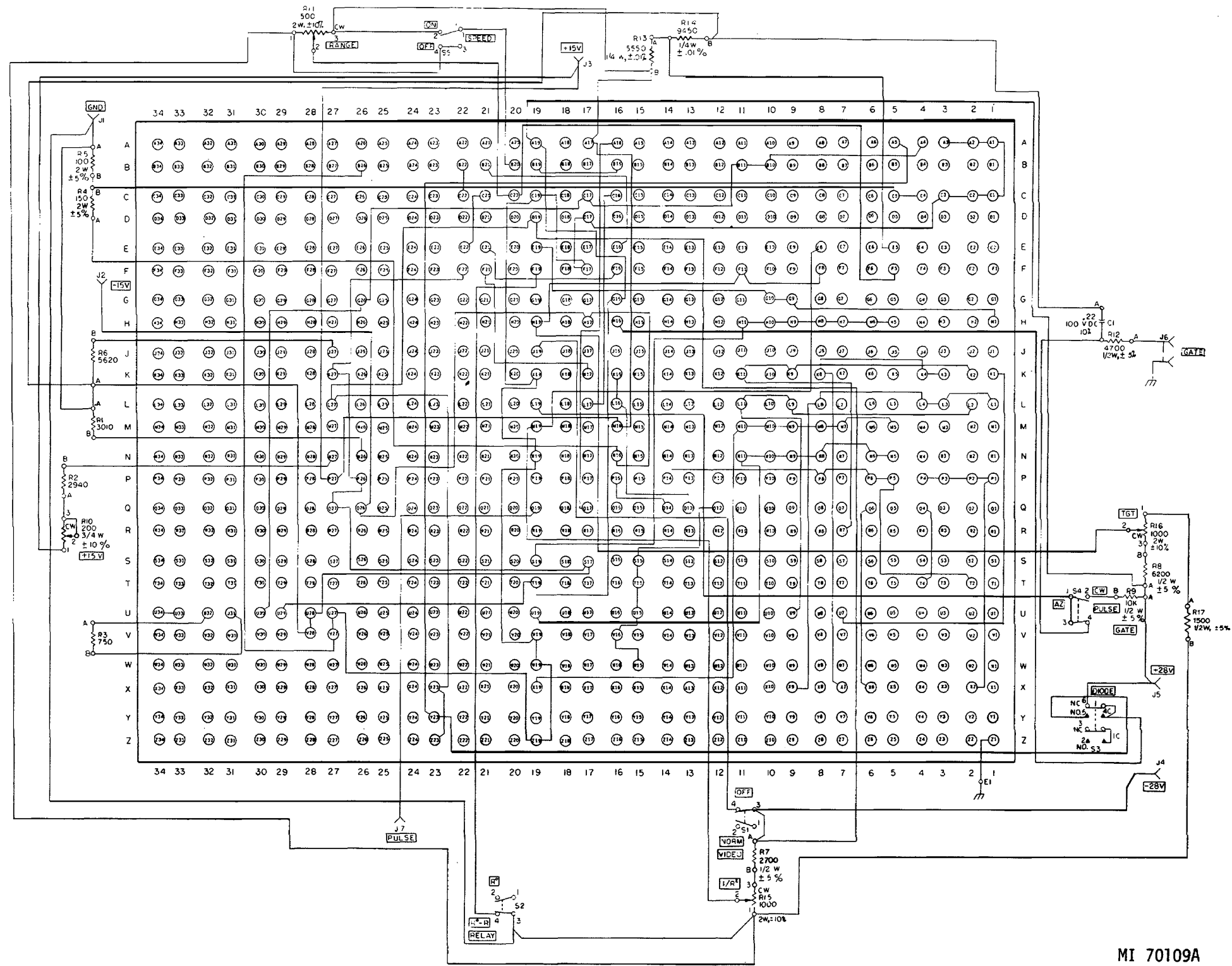

Figure 3-163. Pb HT8-1024A 10669023 (FG 1905) - schematic.

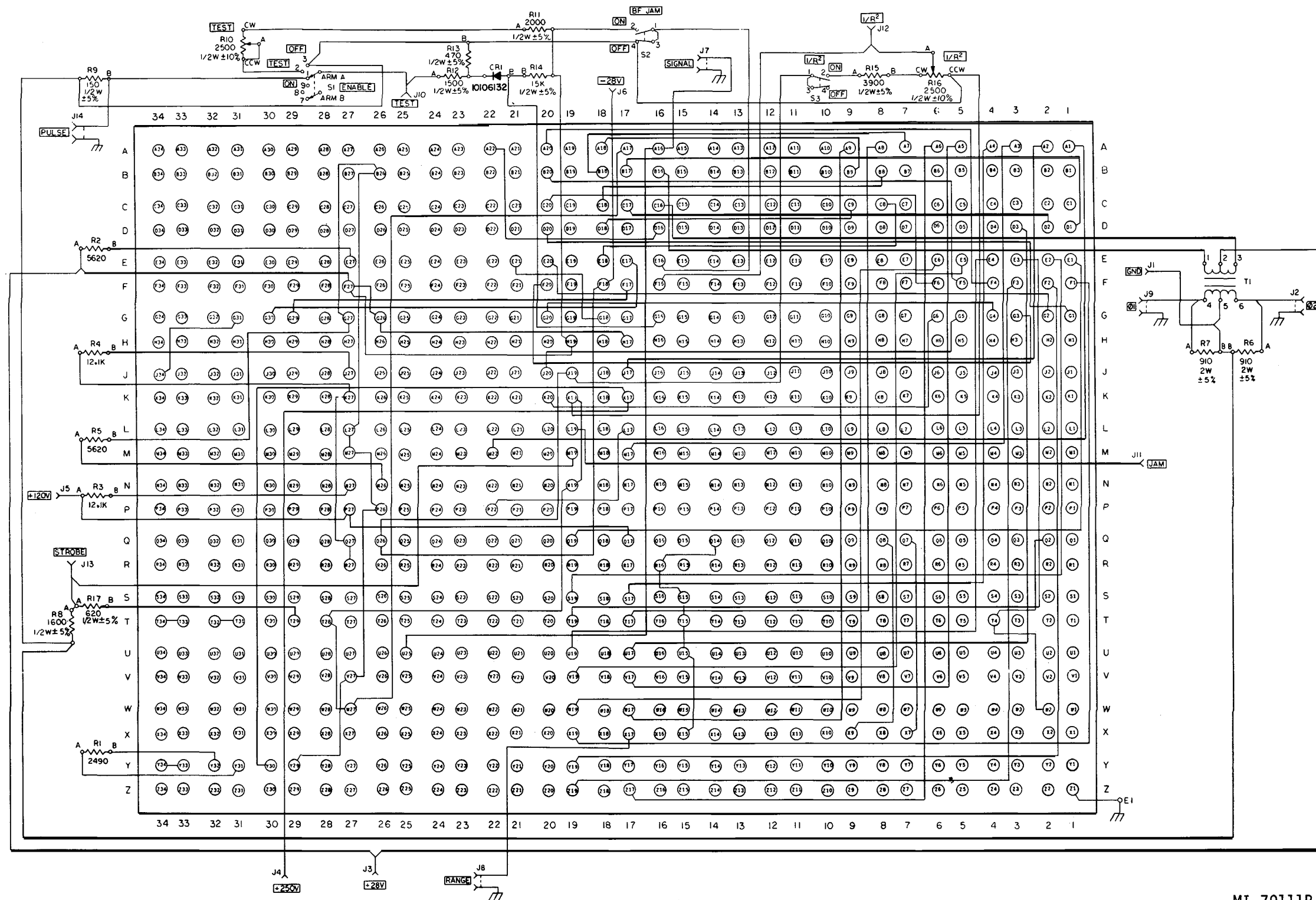

Figure 3-164. Pb HT8-1025A 10288105 (FG 1910) - schematic.

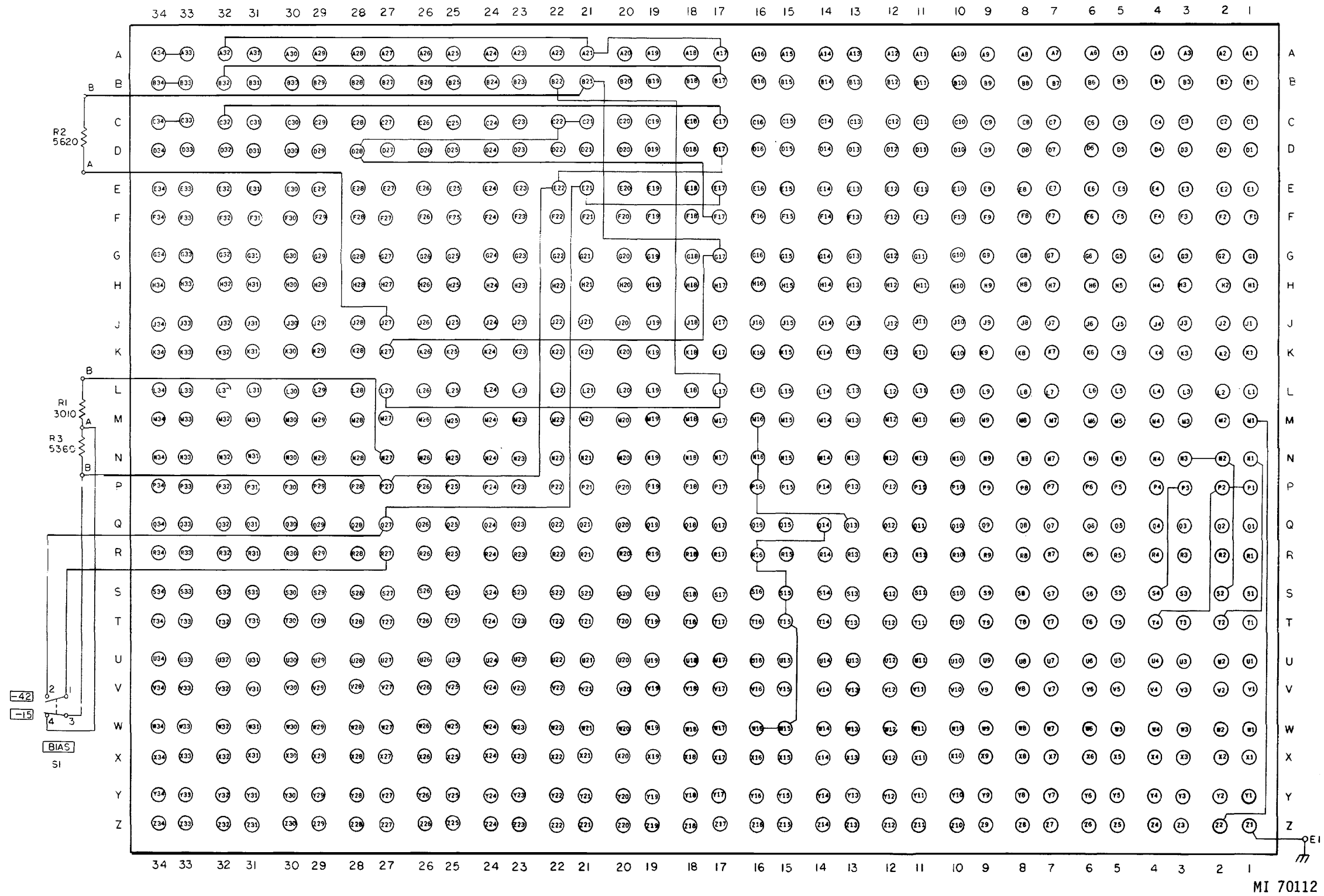

Figure 3-165. Pb HT8-1026 10671795 (FG 1915) - schematic.

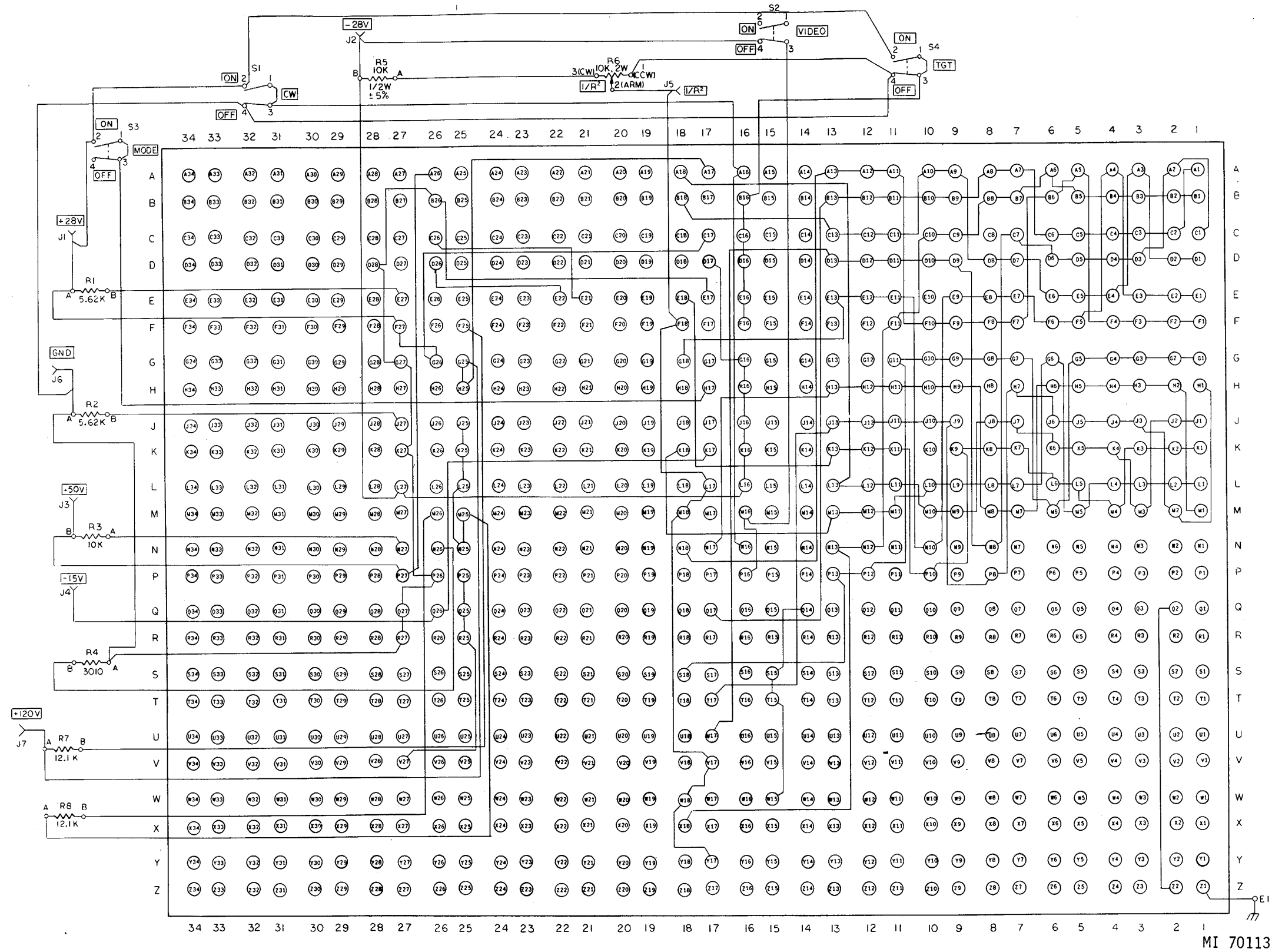
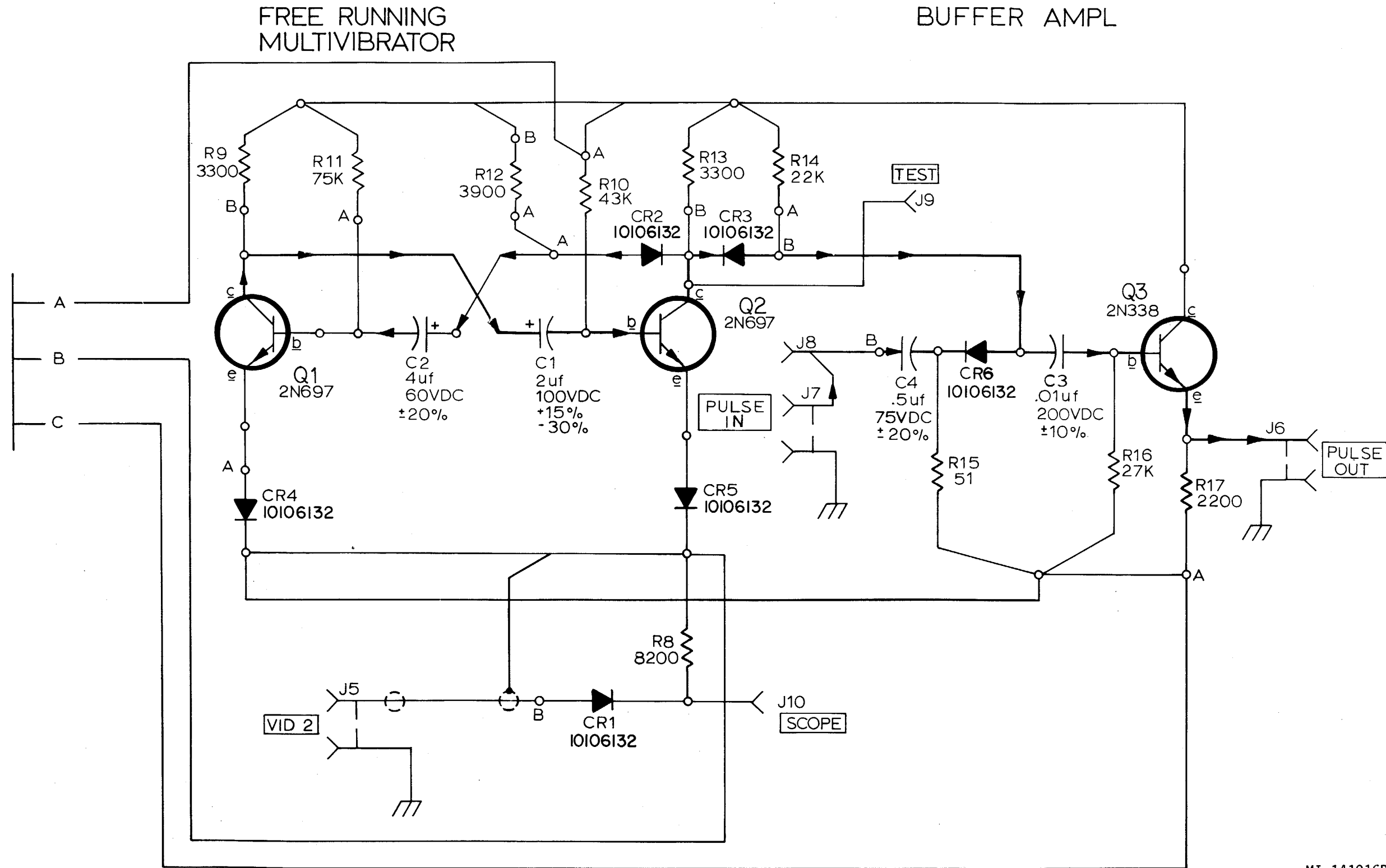

Figure 3-166. Pb HT8-1027 10671688 (FG 1920) - schematic.



MI 141916B

Figure 3-167. HT8-1028B 10288276 (FG 1925) - schematic (sheet 2 of 2).

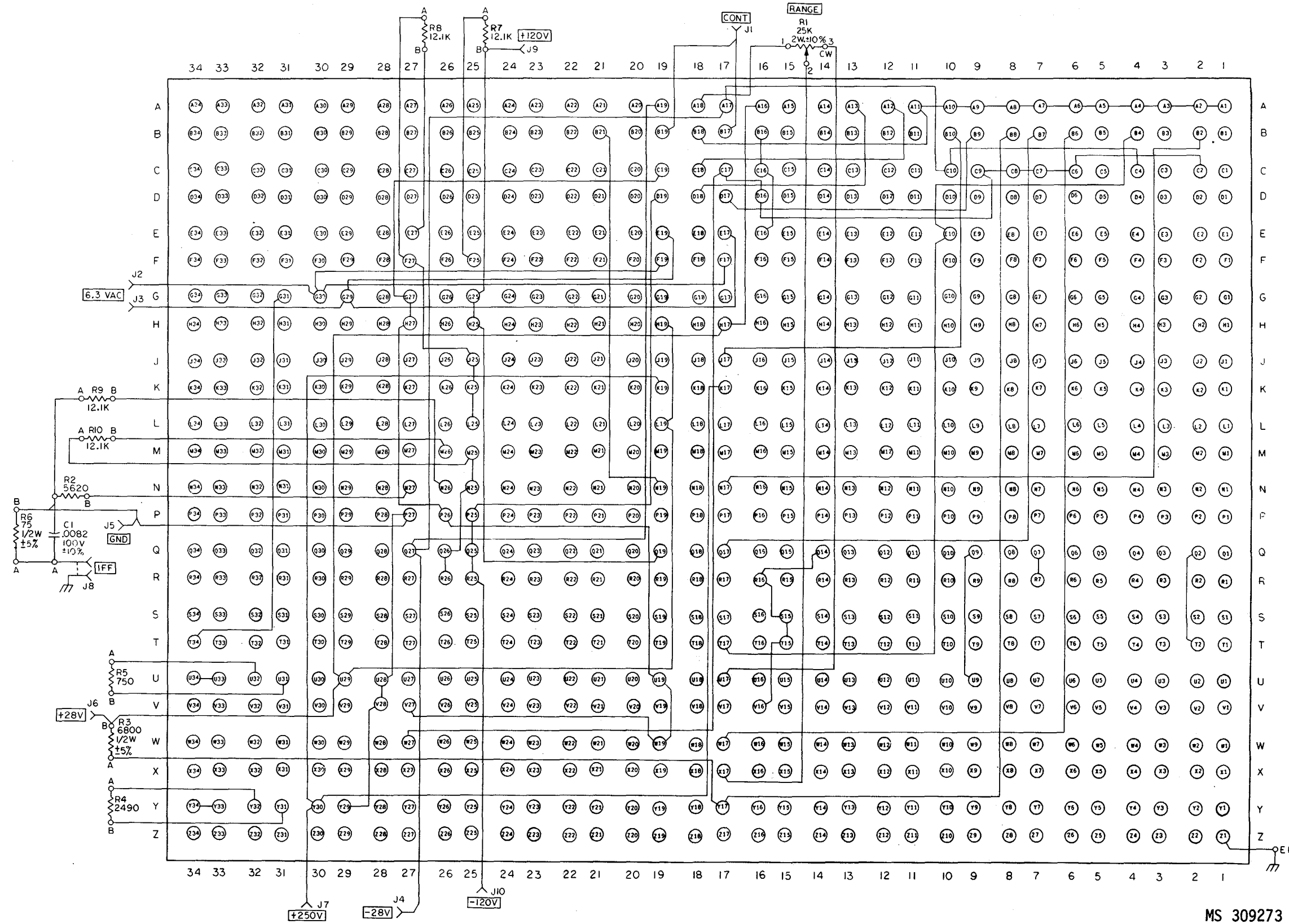

Figure 3-168. Pb HT8-1029A 10288830 (FG 1945) - schematic.

MS 309273

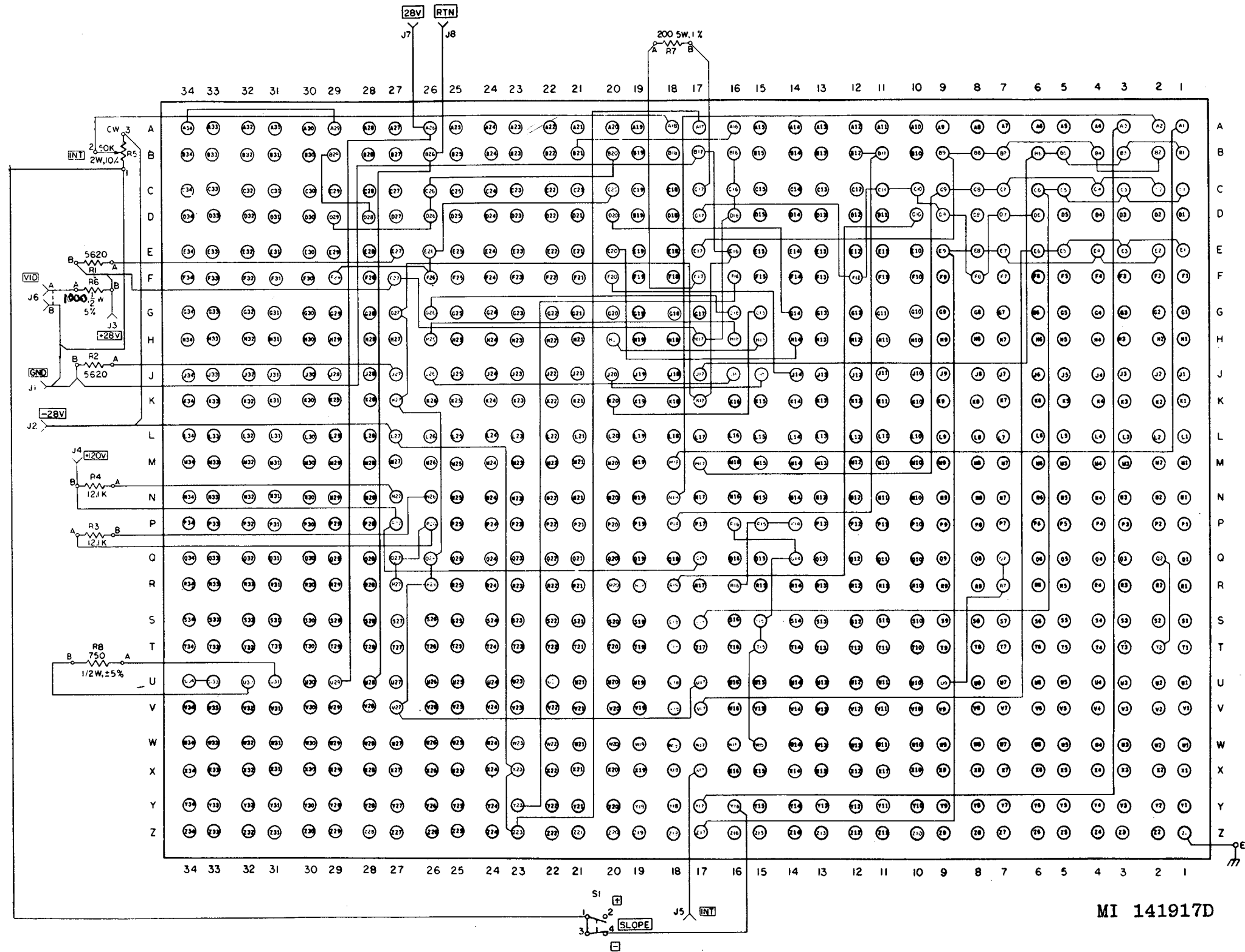

Figure 3-169. Pb HT8-1030A 10288279 (FG 1900) - schematic.

3-227/(3-228 blank)

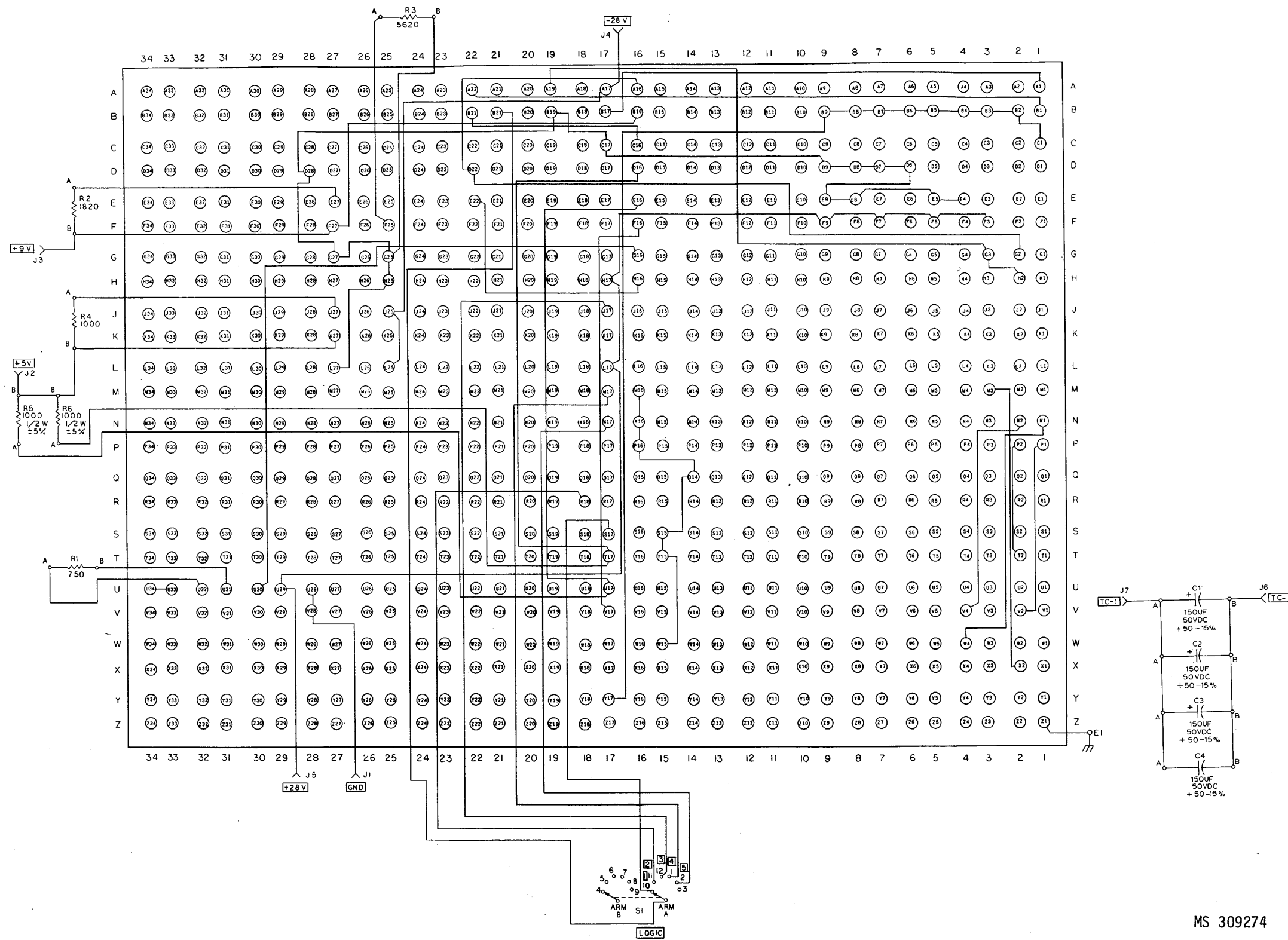
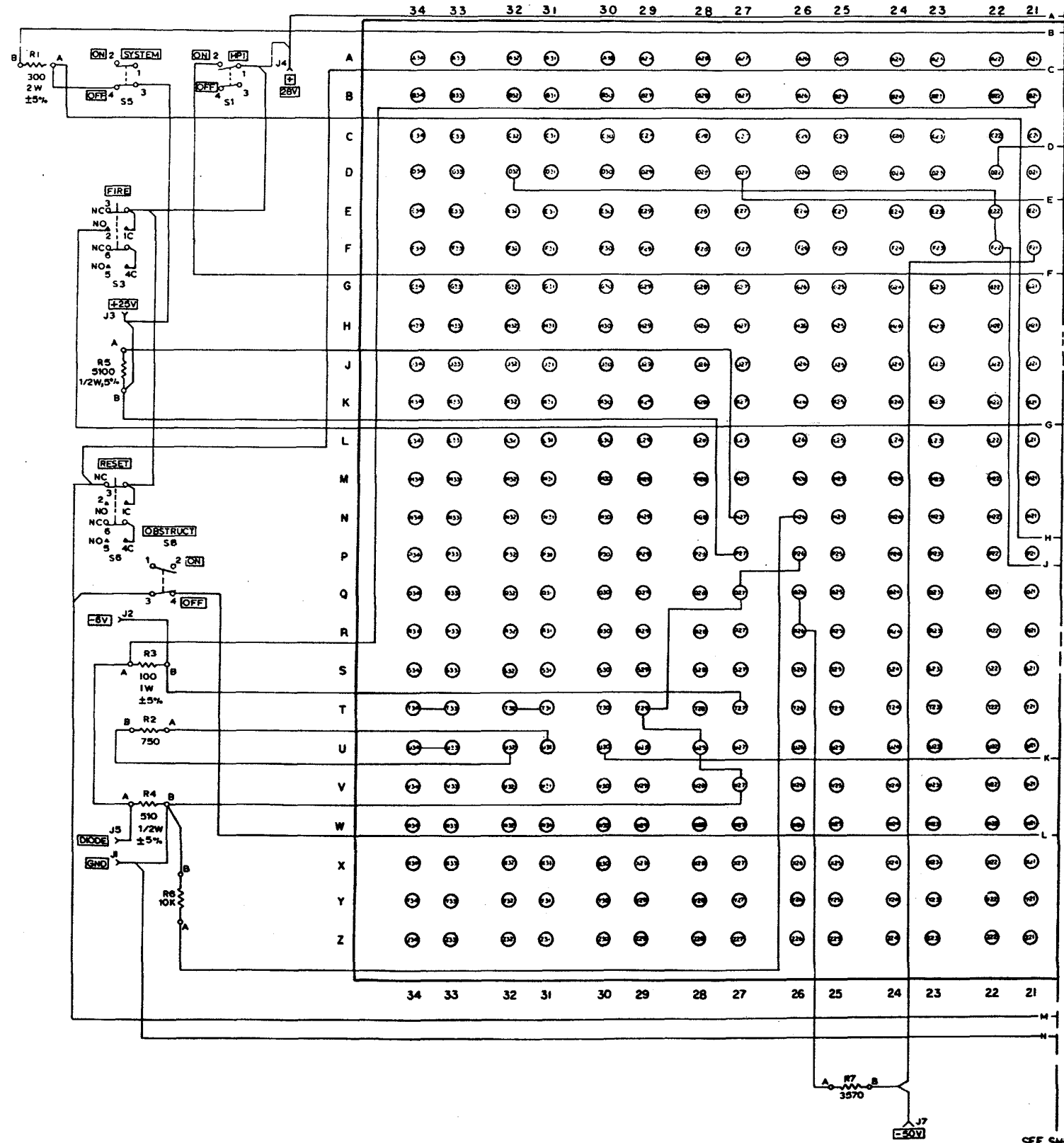

Figure 3-170. Pb HT8-1031 11569535 (FG 3875) - schematic.



SEE SHEET 2
MS 309275

Figure 3-171. Pb L8-104A 10287985 (FG 1930) - schematic (sheet 1 of 2).

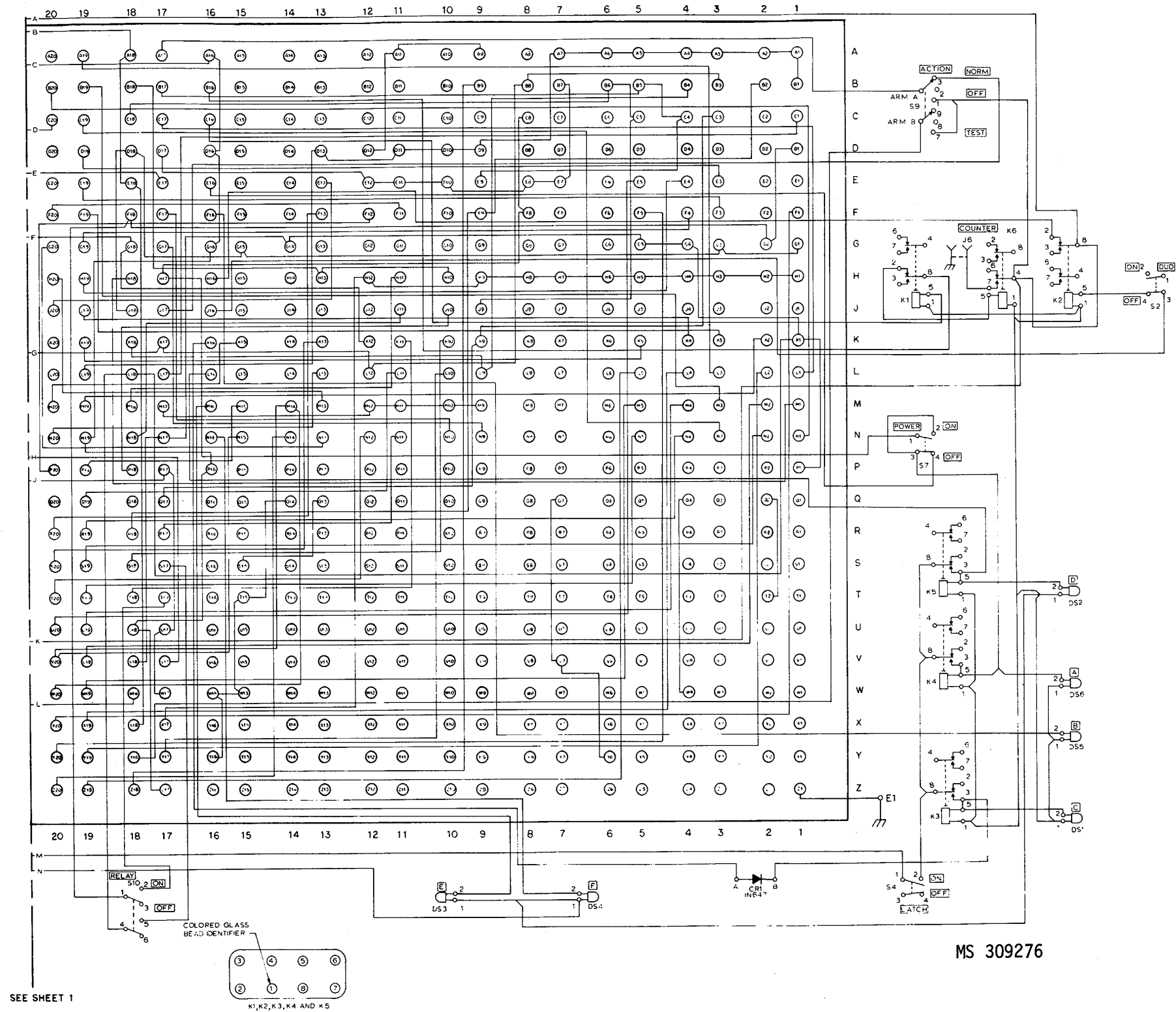

Figure 3-171. Pb L8-104A 10287985 (FG 1930) - schematic (sheet 2 of 2).

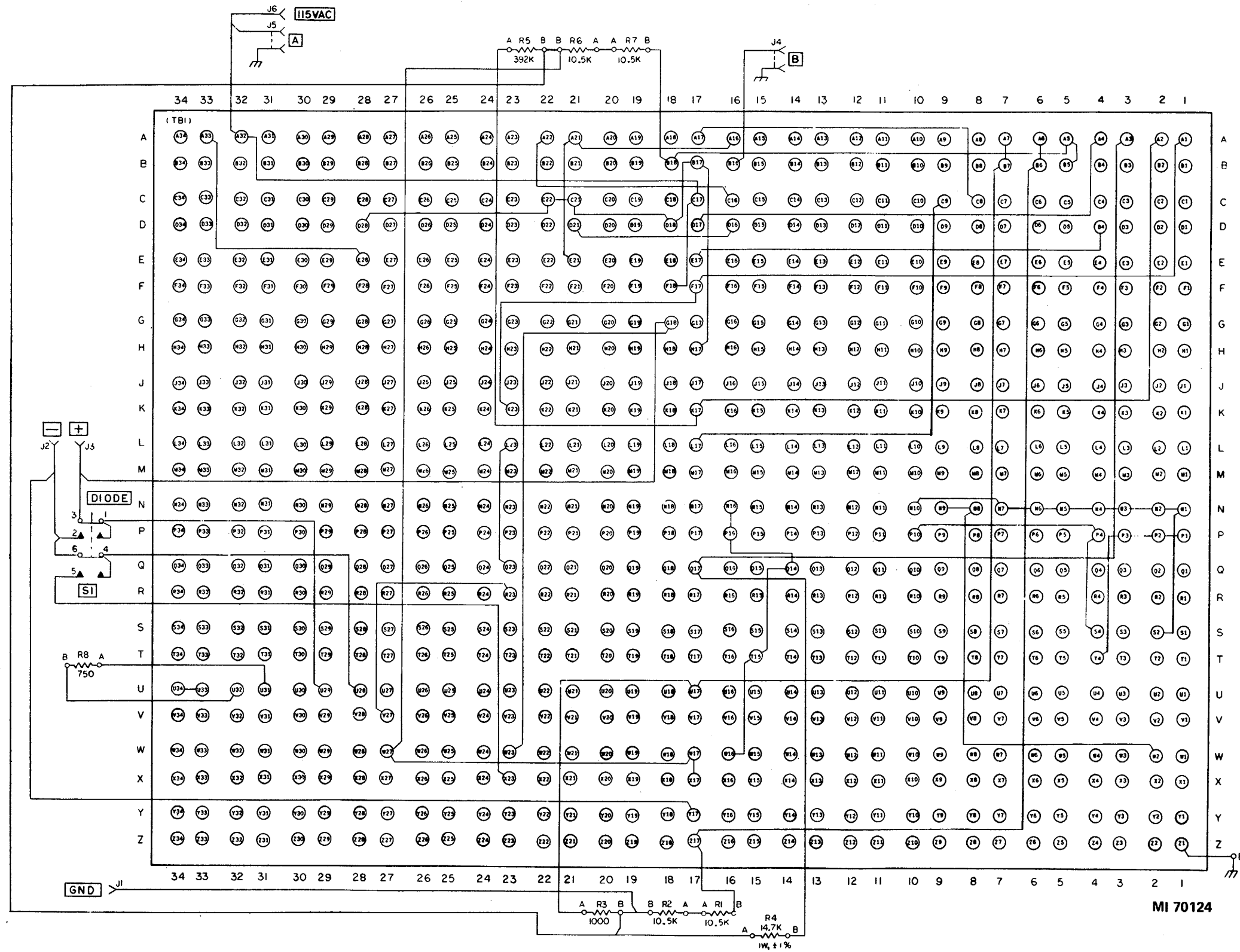

Figure 3-172. Pb L8-105 10670535 (FG 1935) - schematic.

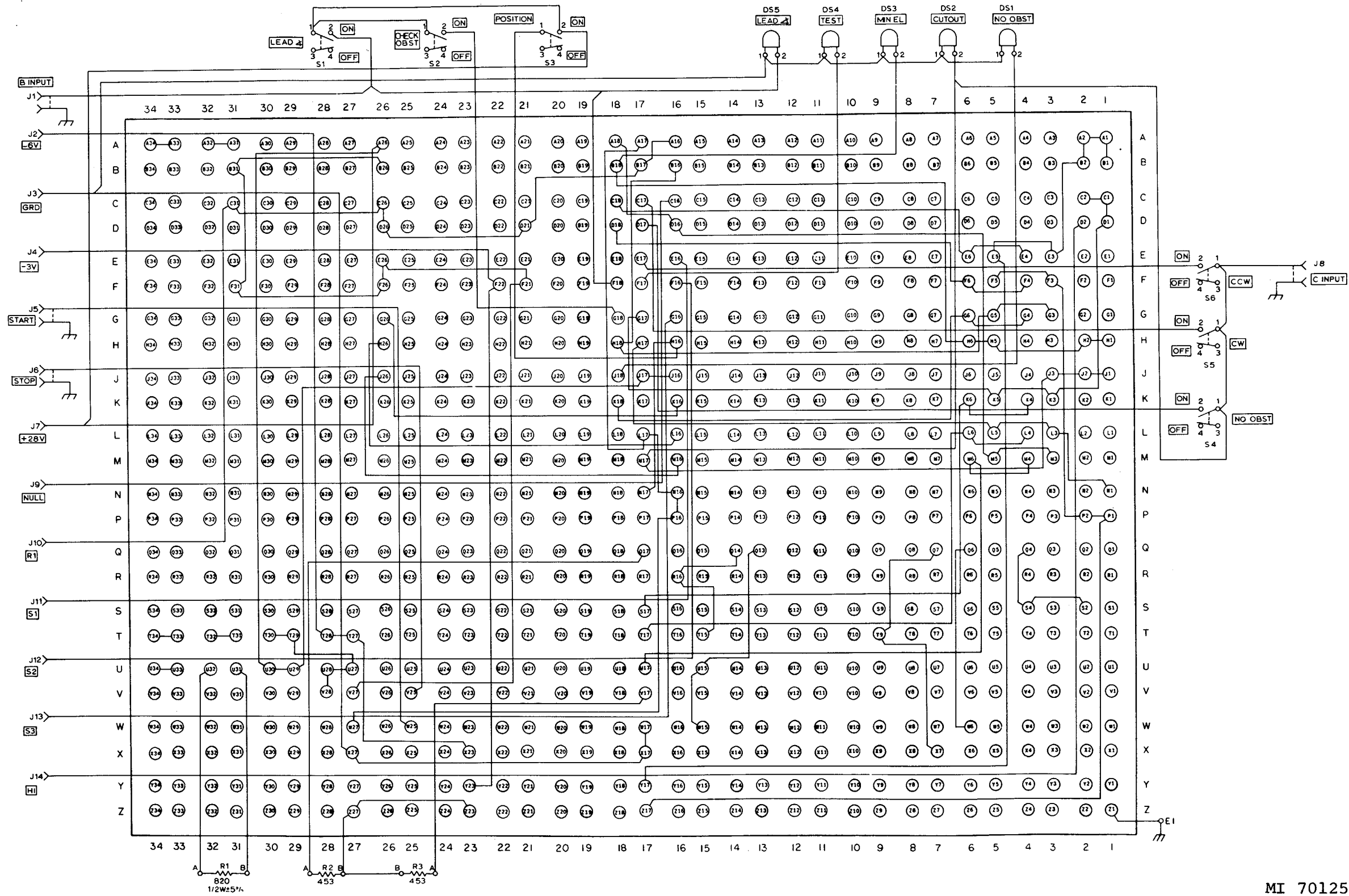

Figure 3-173. Pb L8-106 10675513 (FG 1967) - schematic.

MI 70125

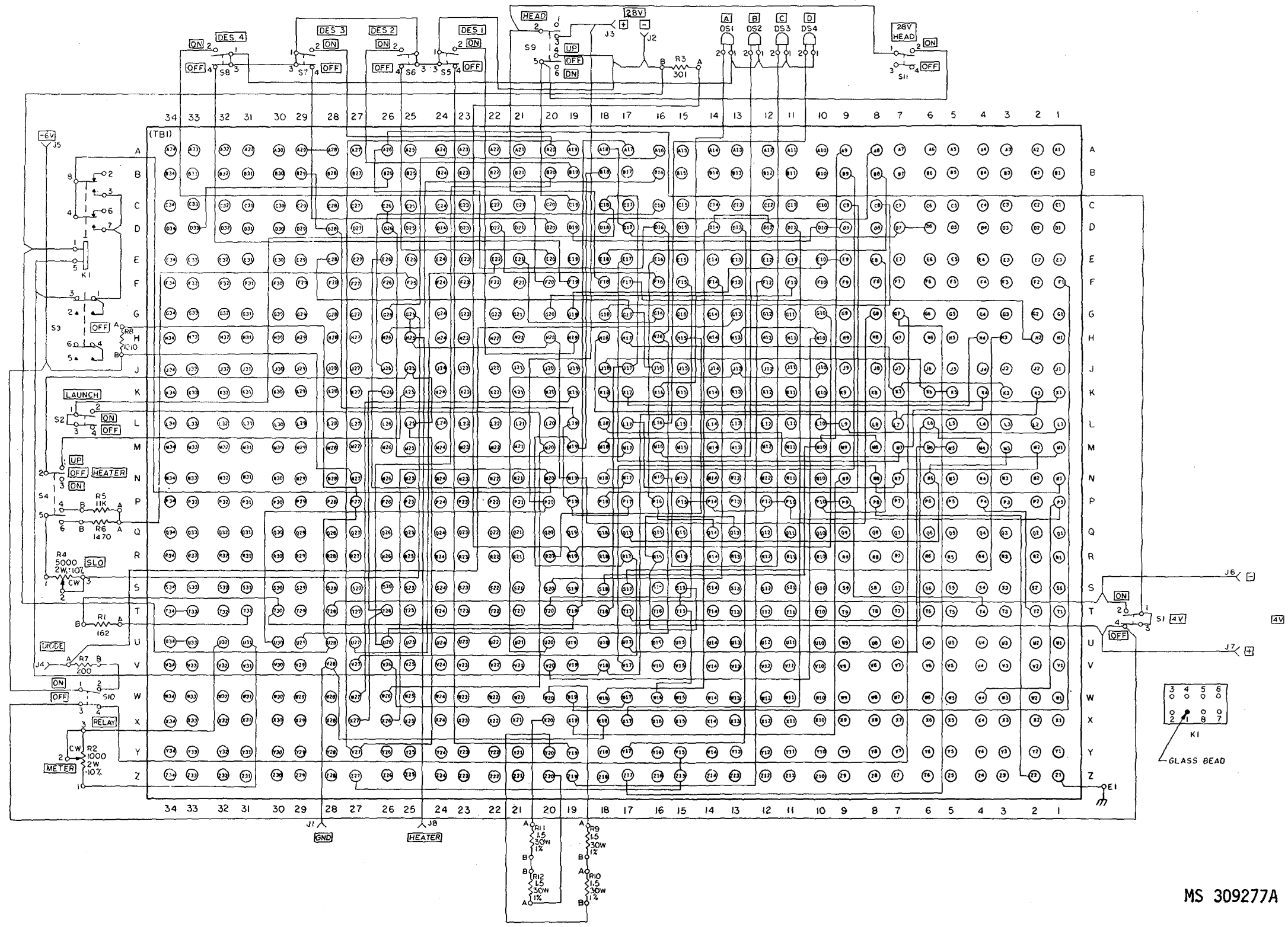
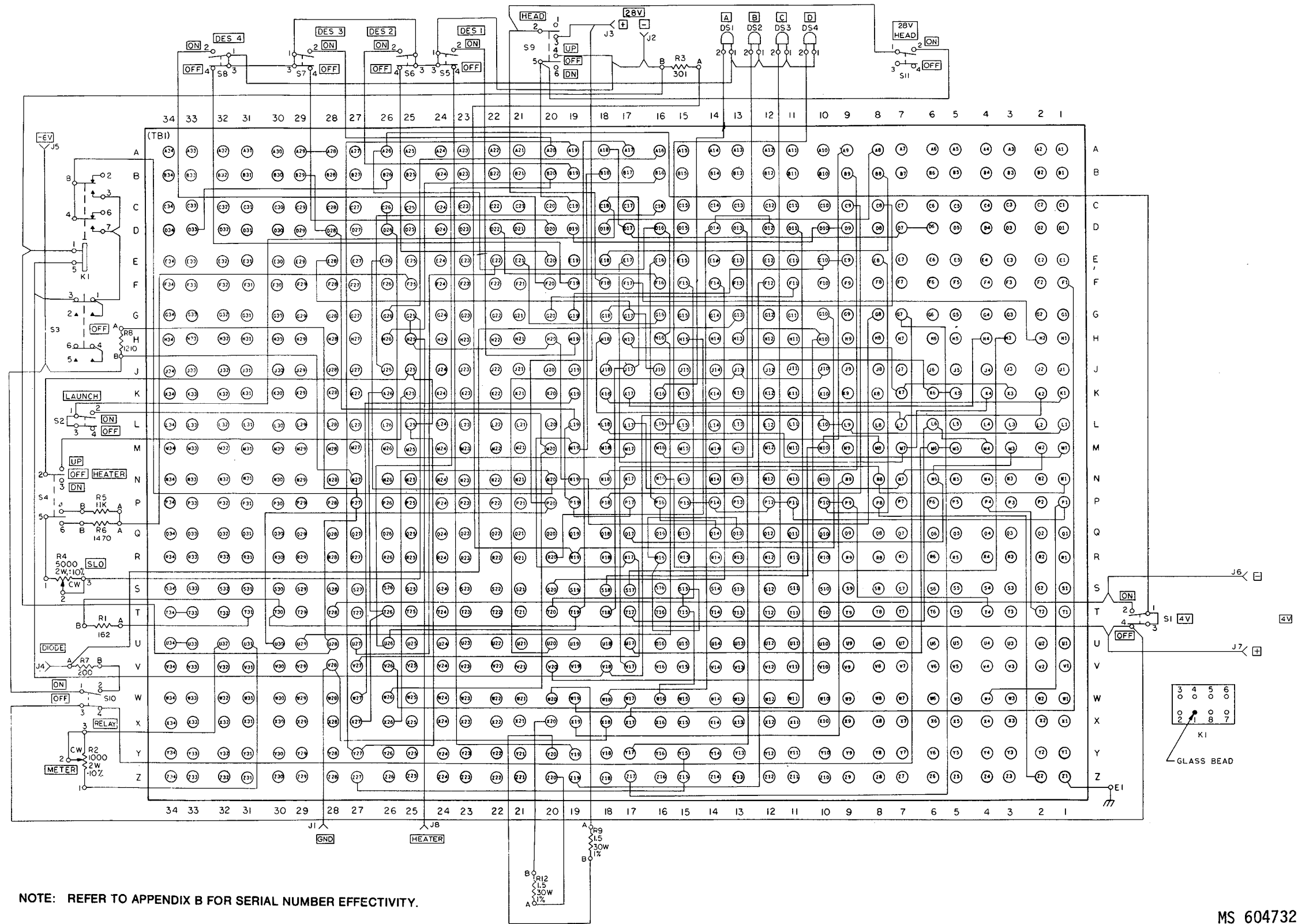

Figure 3-174. Pb OME8-103A 10287982 (FG 1940) - schematic.

MS 309277A



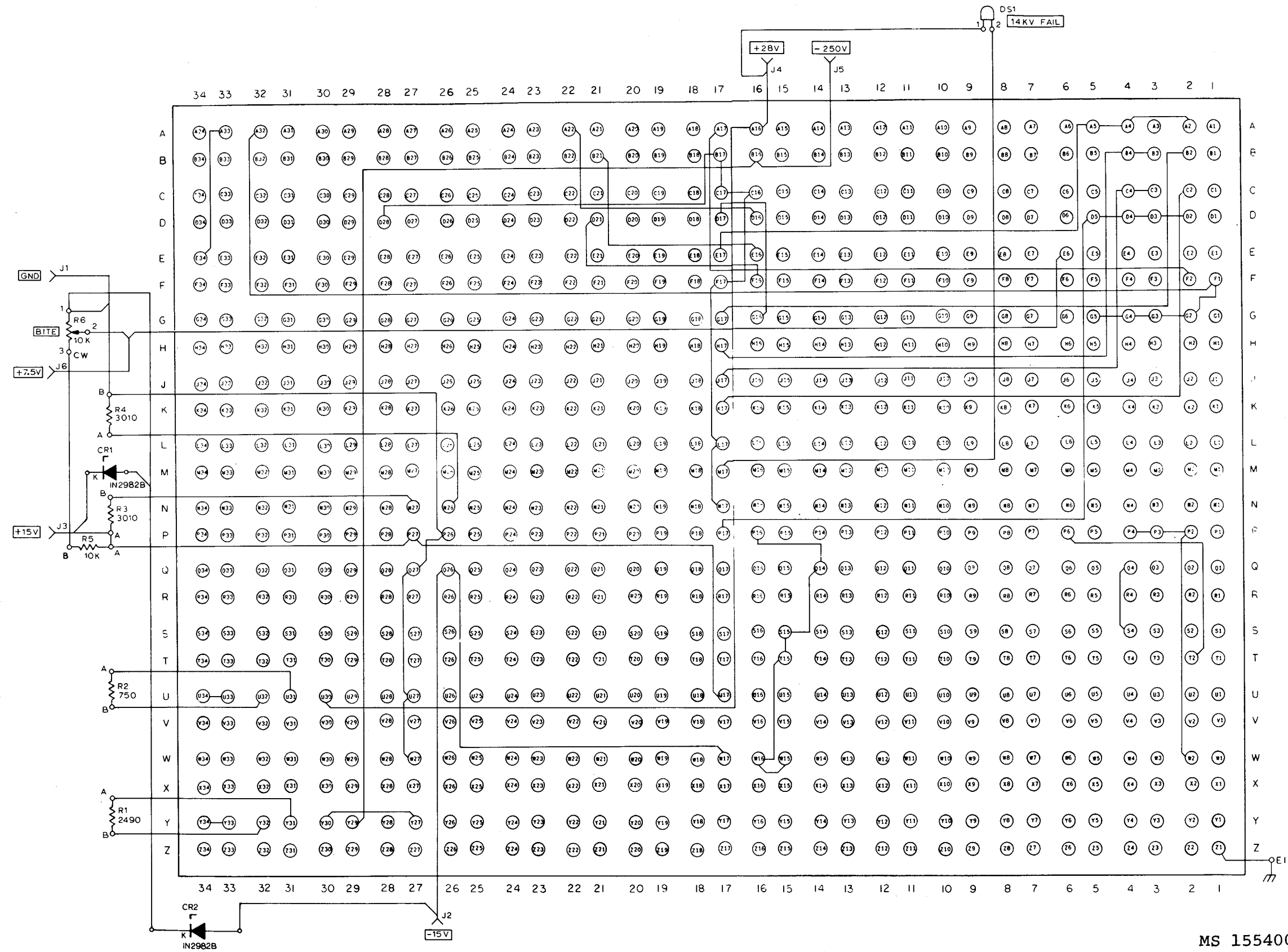
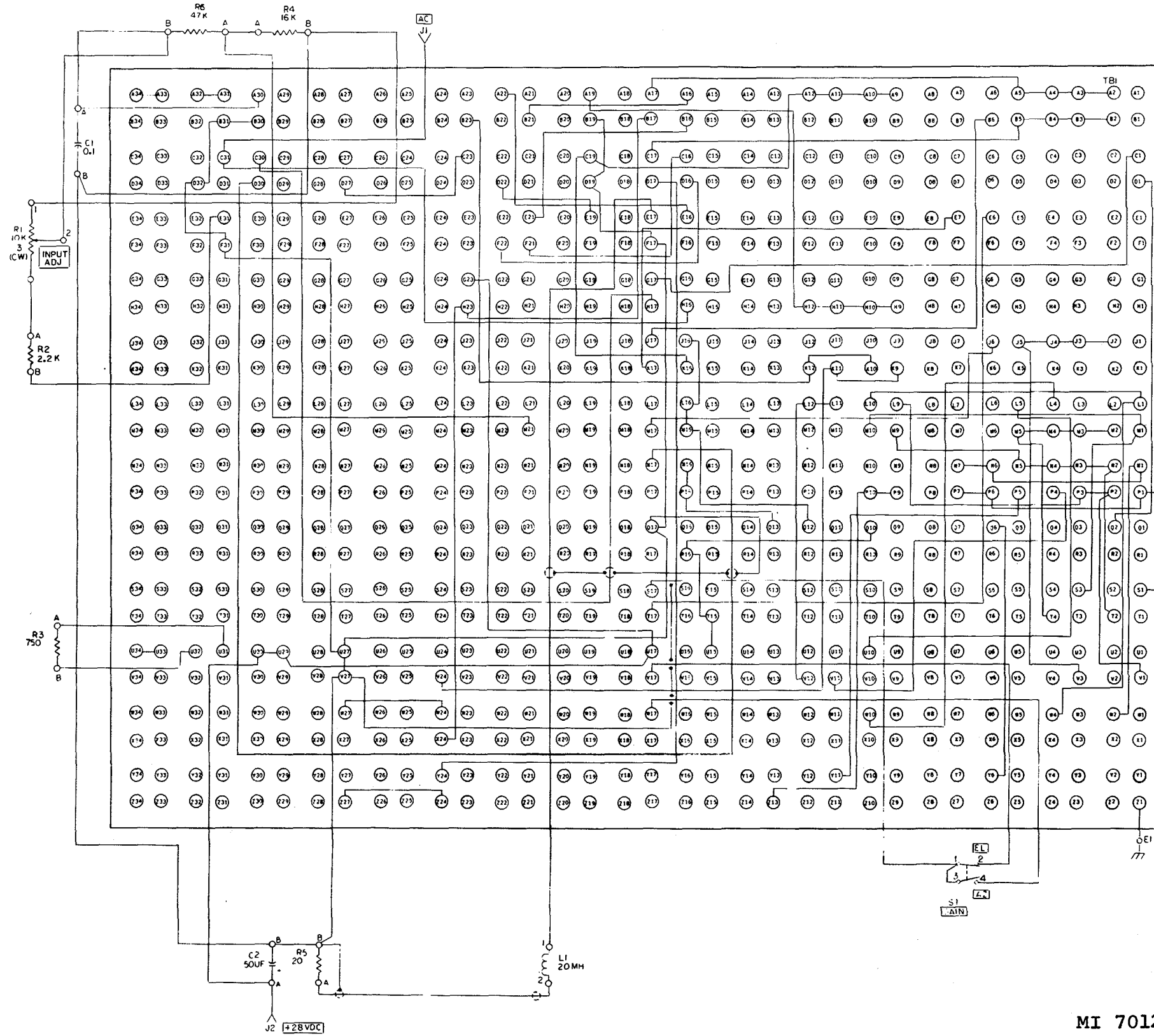

Figure 3-175. Pb PCP9-106 10288206 (FG 4600) - schematic.

MS 155400



MI 70128

Figure 3-176. Pb SPHL7-101A 10176923 (FG 1560) - schematic.

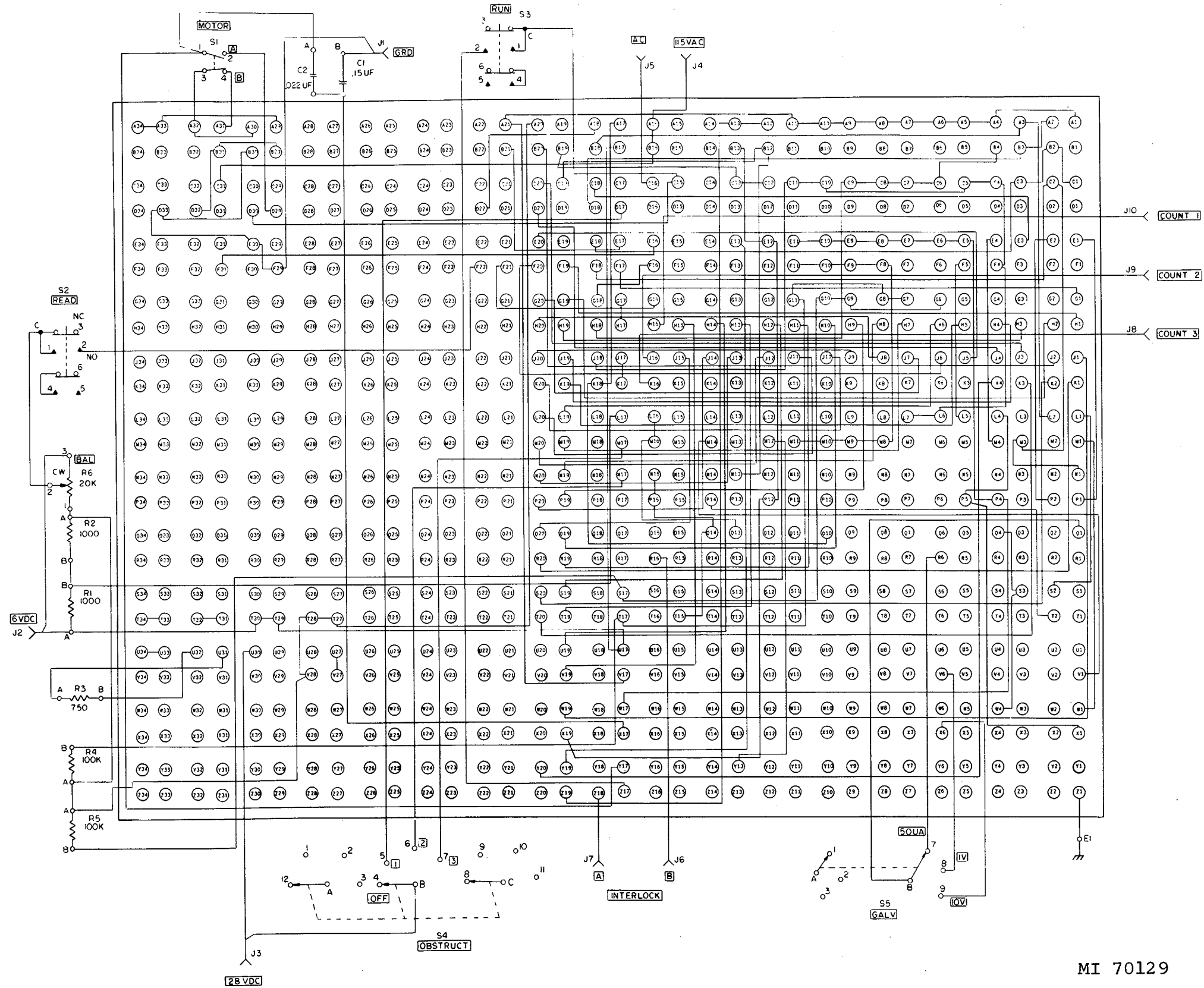

Figure 3-177. Pb SPHL7-103A 10183600 (FG 1745) - schematic.

MI 70129

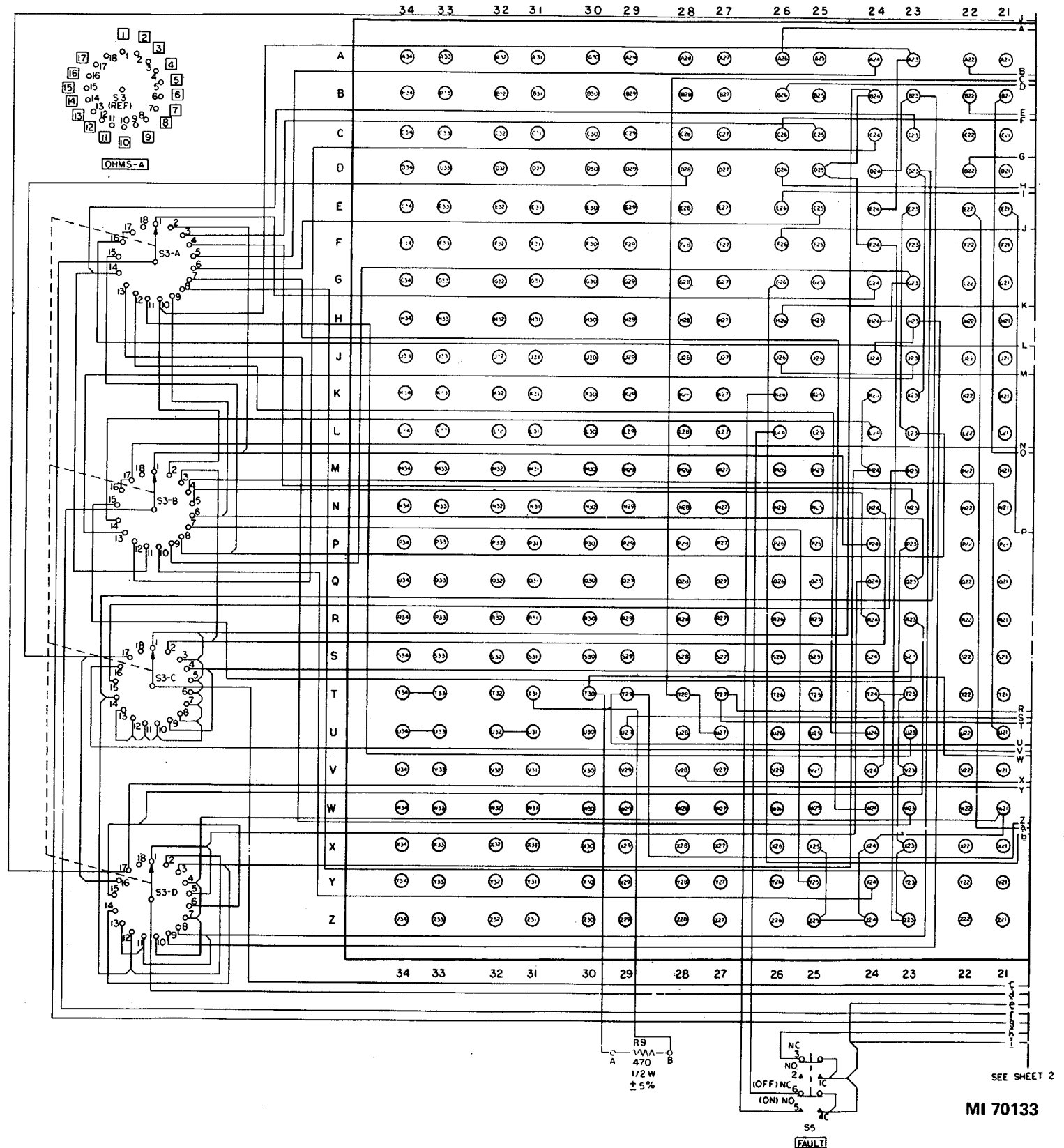
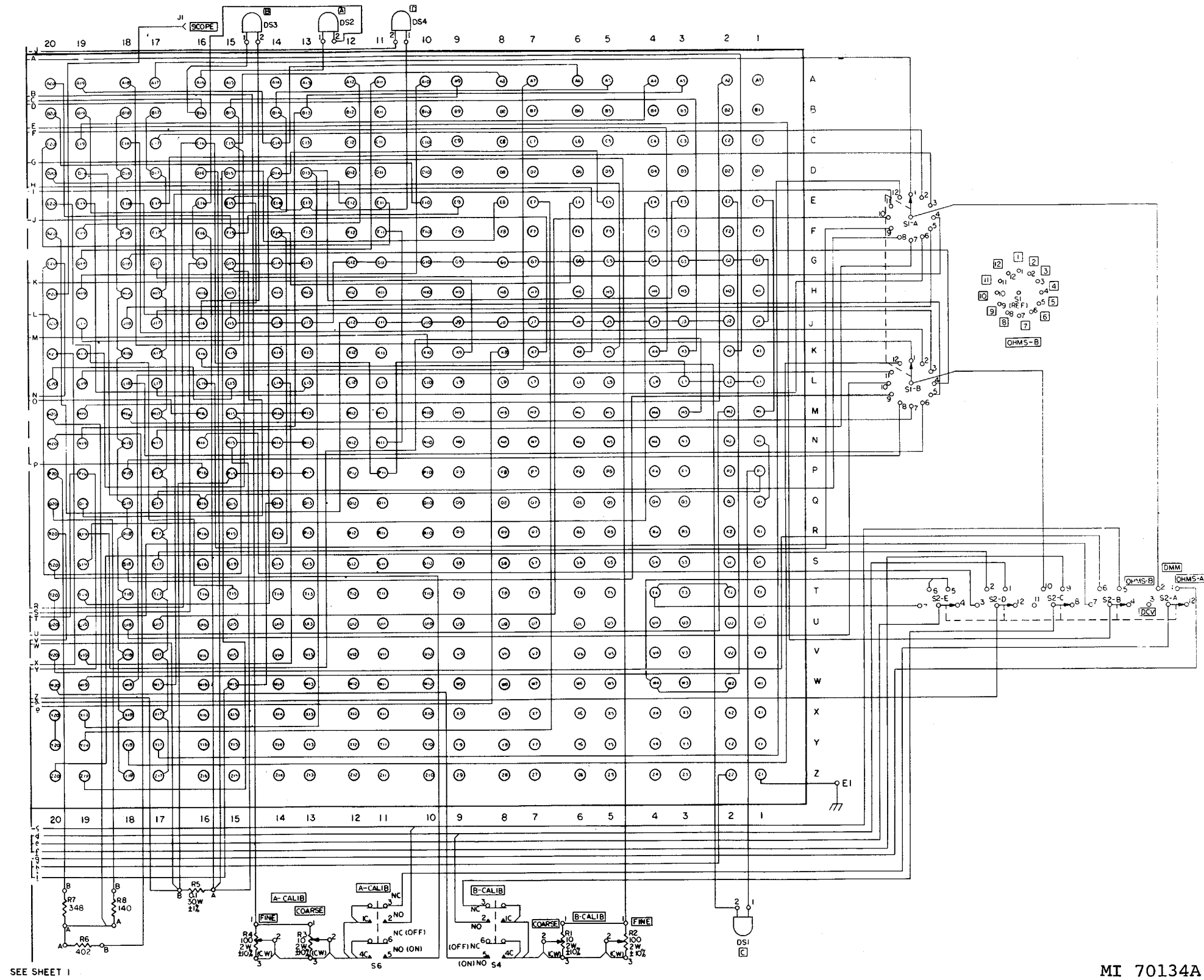

Figure 3-180. Pb SC8-101 10671771 (FG 1950) - (sheet 1 of 2).



SEE SHEET 1

MI 70134A

Figure 3-180. Pb SC8-101 10671771 (FG 1950) - (sheet 2 of 2).

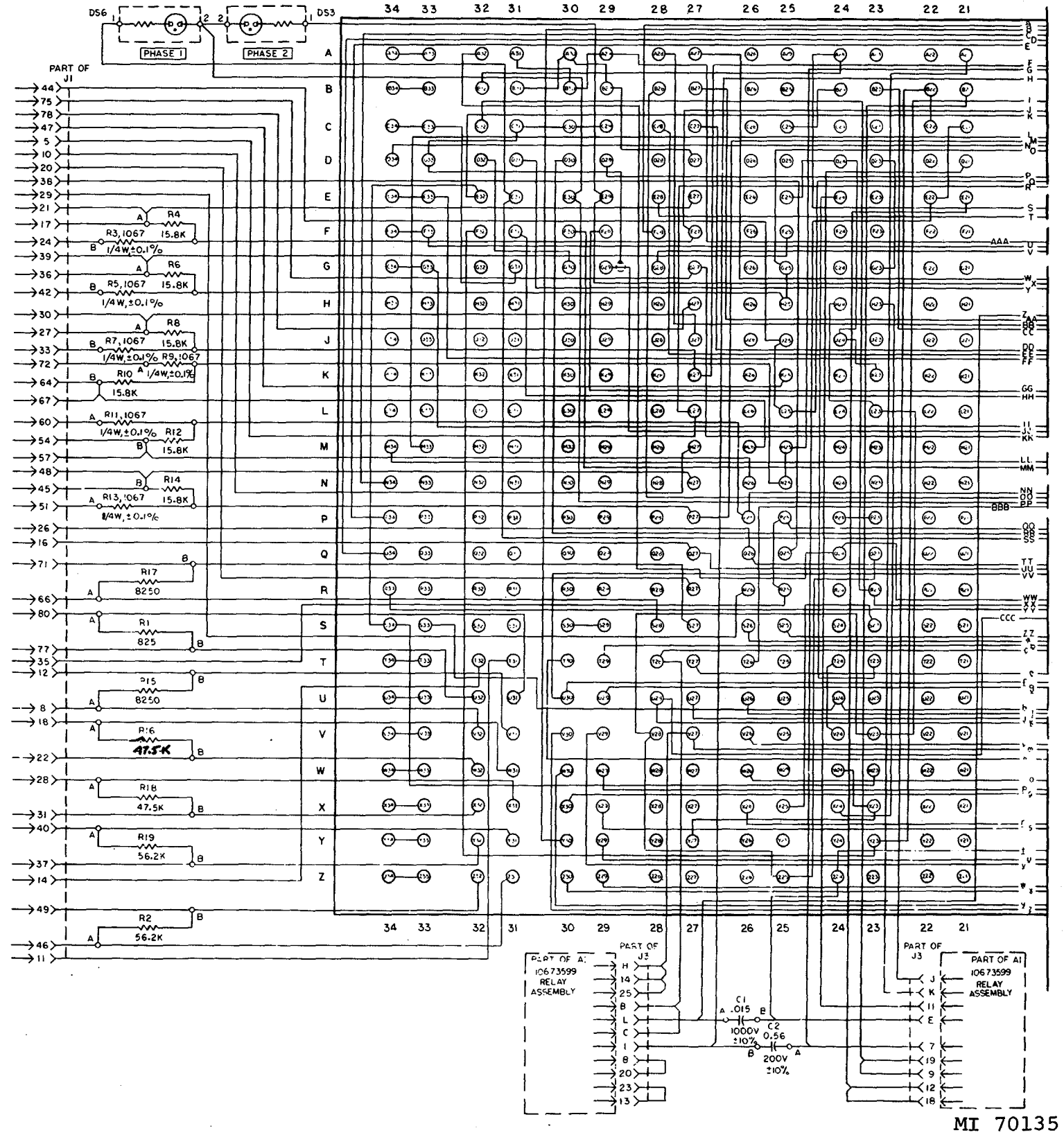

MI 70135

Figure 3-181. Pb SC8-102 10671772 (FG 1955) - schematic (sheet 1 of 2).

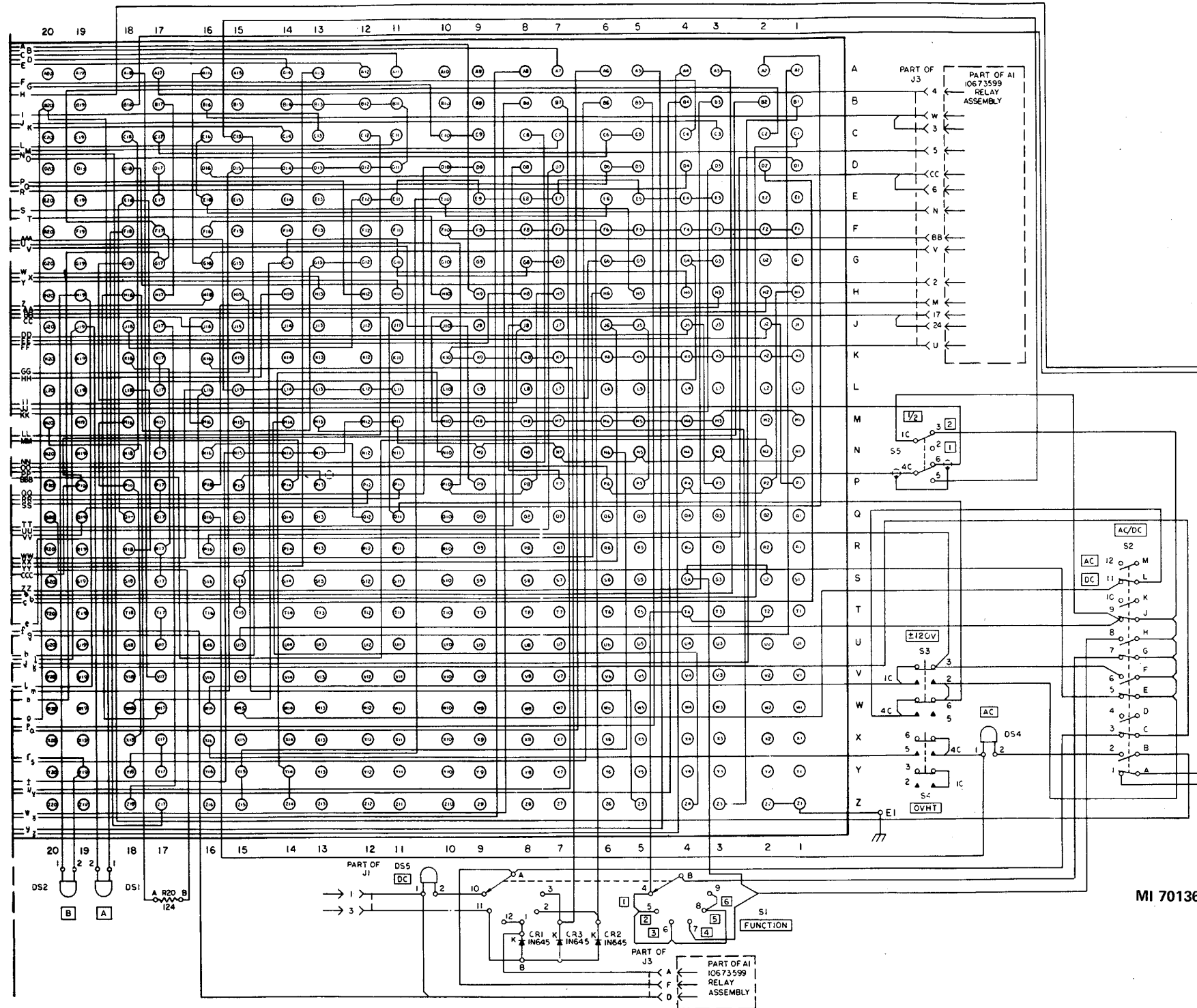

Figure 3-181. Pb SC8-102 10671772 (FG 1955)-schematic (sheet 2 of 2)
3-243

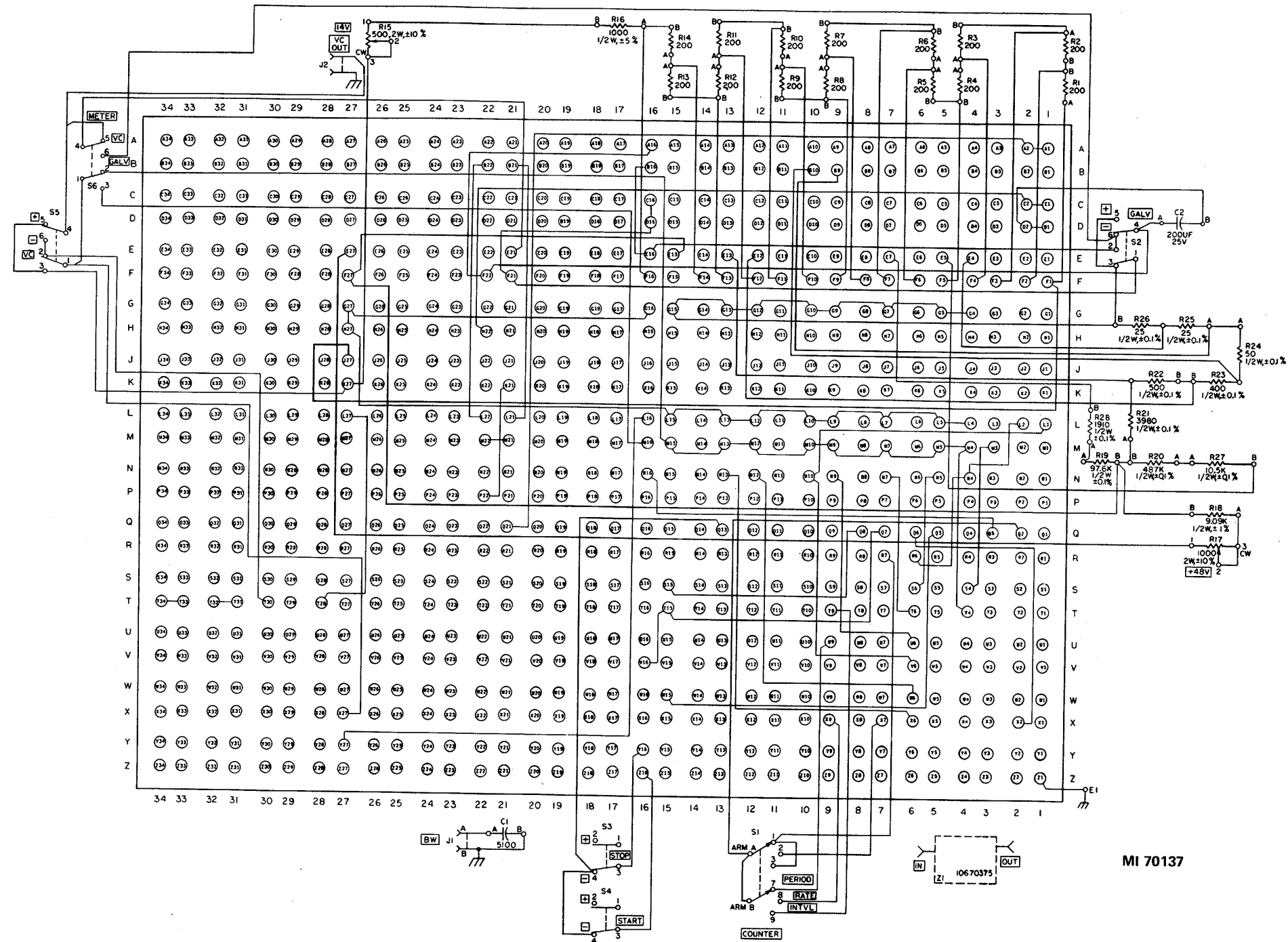
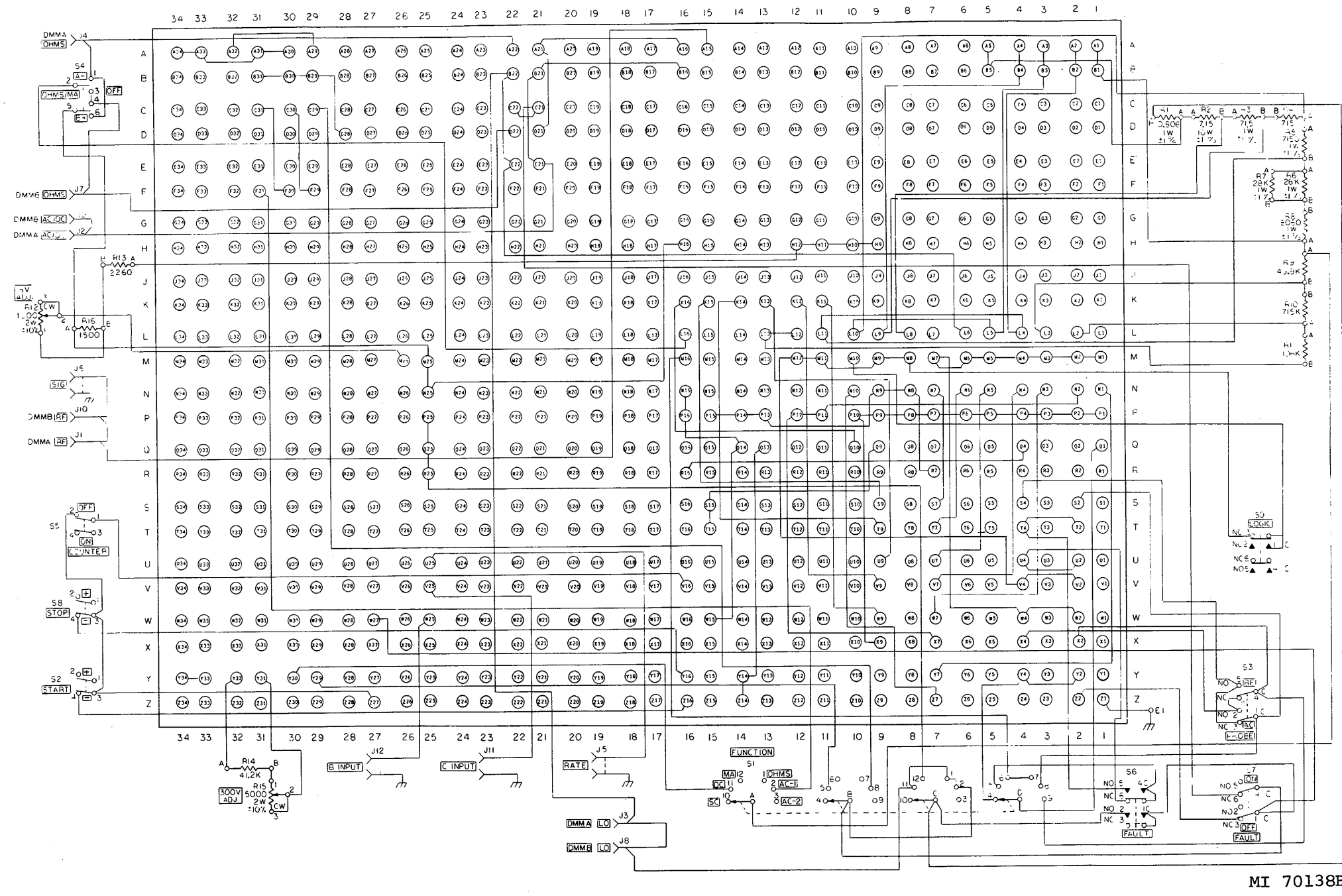
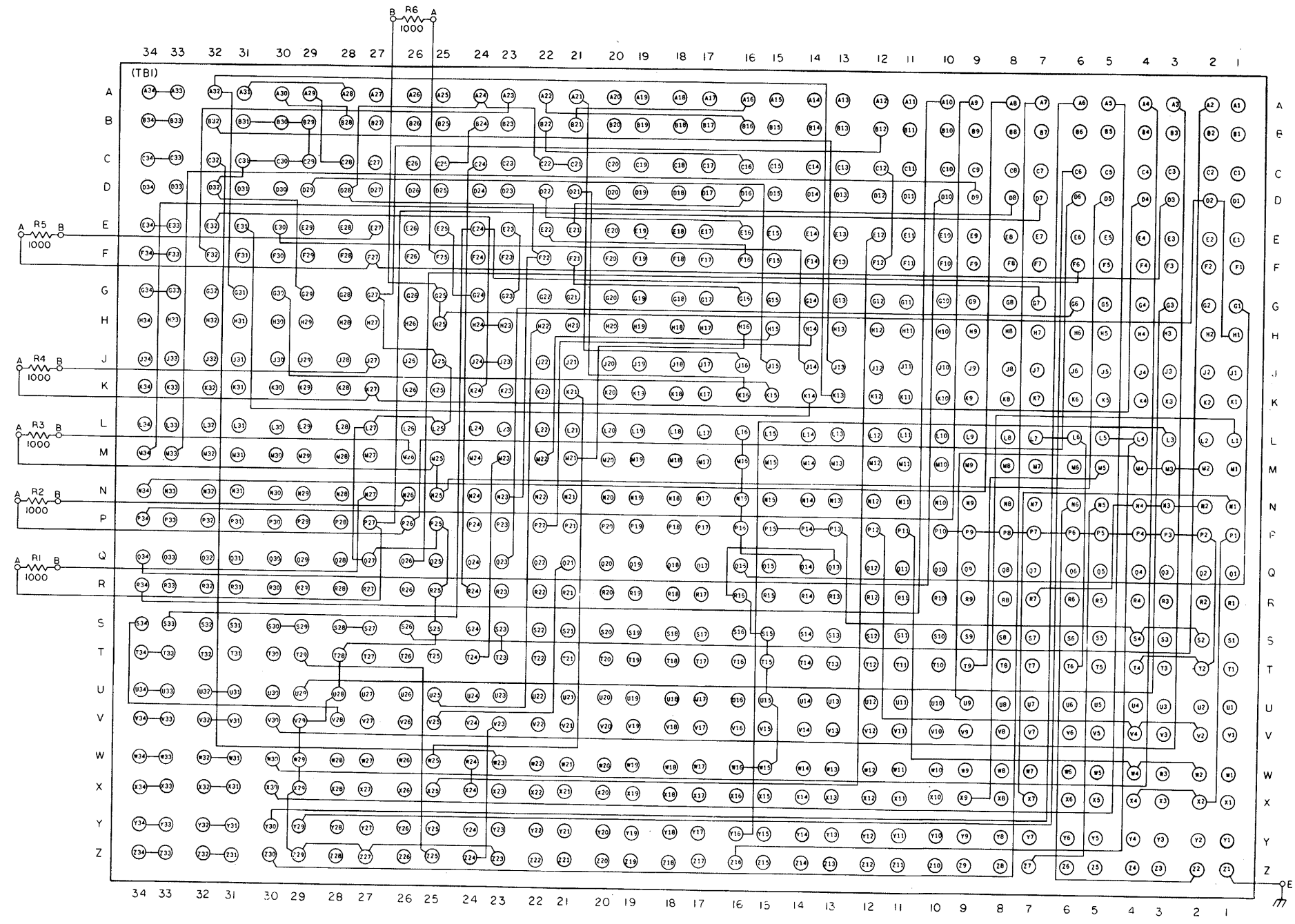

Figure 3-182. Pb SC8-103 10670597 (FG 1960)-schematic.
3-244



MI 70138B

Figure 3-183. Pb SC8-104 10671609 (FG 1965)-schematic.
3-245



MI 70139

Figure 3-184. Pb SC8-105 10671773 (FG 1500)-schematic.
3-246

Section III. ACCESSORIES

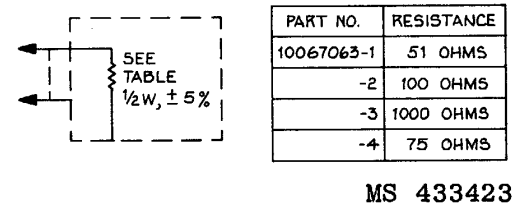

Figure 3-184.1. BMS terminations 51 ohm 10067063-1, 100 ohm 10067063-2, 1000 ohm 10067063-3, and 75 ohm 10067063-4-schematic.

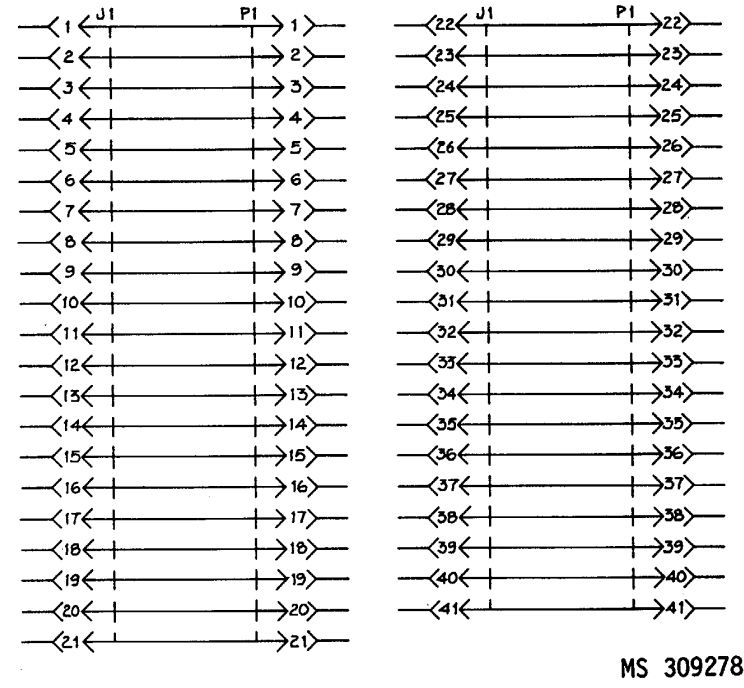

Figure 3-185. Test adapter (41 pin card extender) 11566544-schematic.

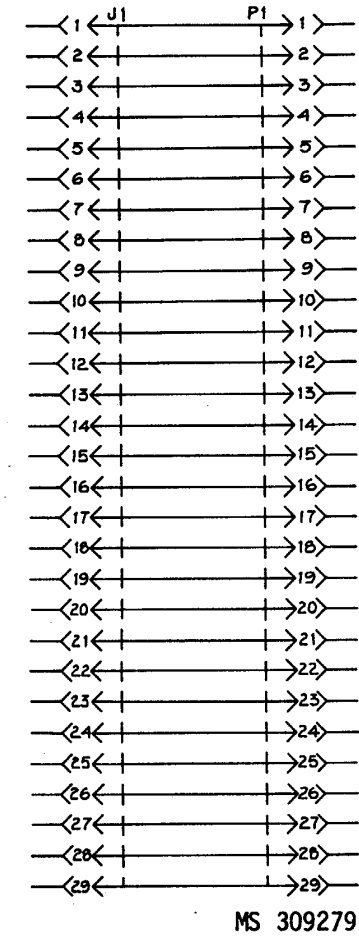

Figure 3-186. Test adapter (29 pin card extender) 11566409-schematic.

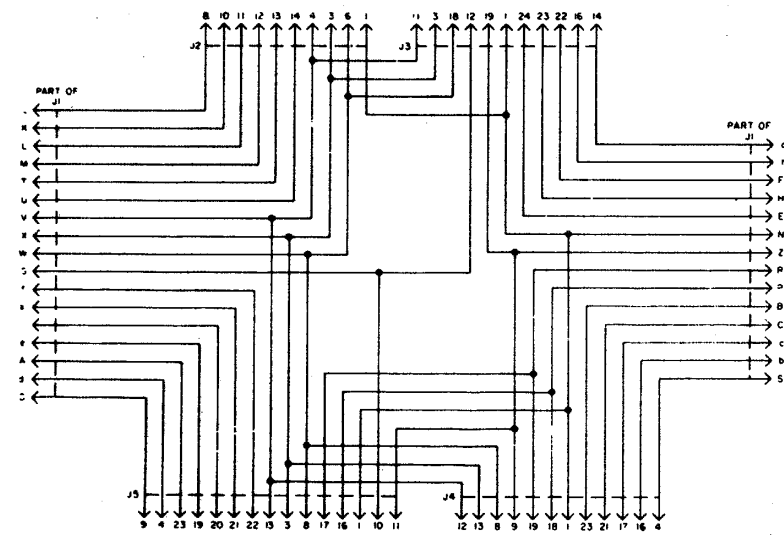

Figure 3-187. Test adapter (wired circuit module) 10112031-schematic.

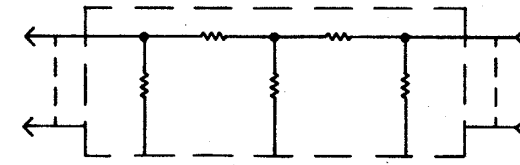

Figure 3-188. Test adapter TA8-103 10670748-schematic.

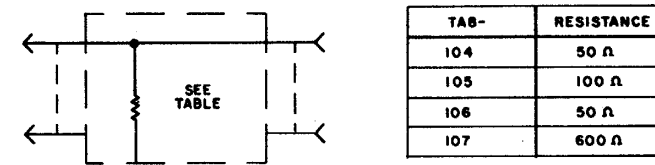

Figure 3-189. Test adapters TA8-104 10670746, TA8-105 10670747-2, TA8-106 10670747-1, and TA8-107 10670747-3-schematic.

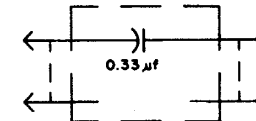

Figure 3-190. Test adapter TA8-1010 10671774-schematic.

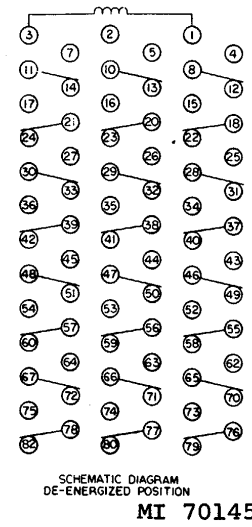

Figure 3-194. Test adapter TA8-1019 10672246-schematic.

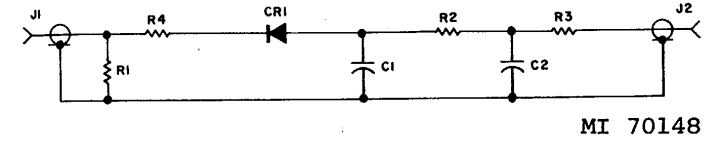

Figure 3-194. Test adapter TA8-1019 10672246-schematic.

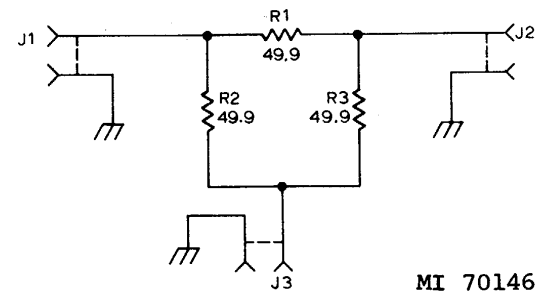

Figure 3-192. Test adapter TA8-1017 10675343 (FG 3820)-schematic.

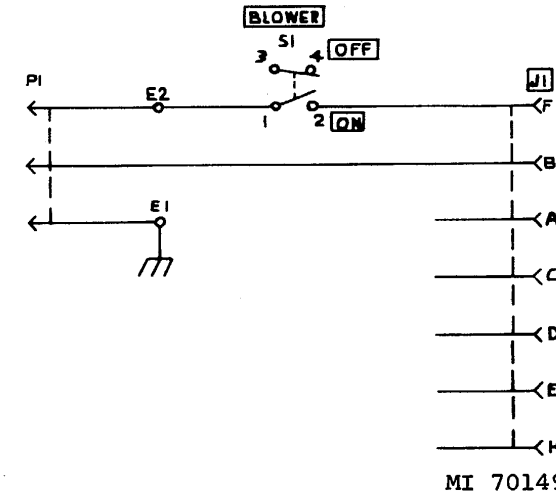

Figure 3-195. Test adapter TA8-1020 (air cooler adapter) 10676869 (FG 3830)-schematic.

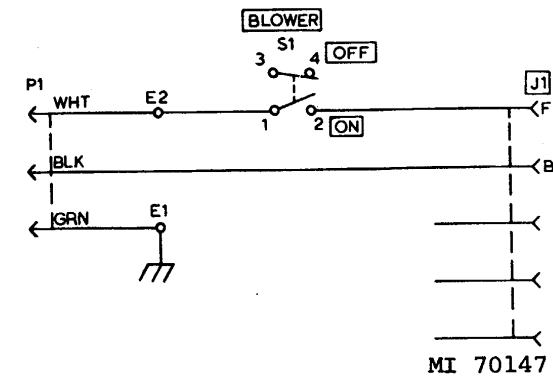

Figure 3-193. Test adapter TA8-1018 (air cooler adapter) 10676444 (FG 3825)-schematic.

3-249

3-249

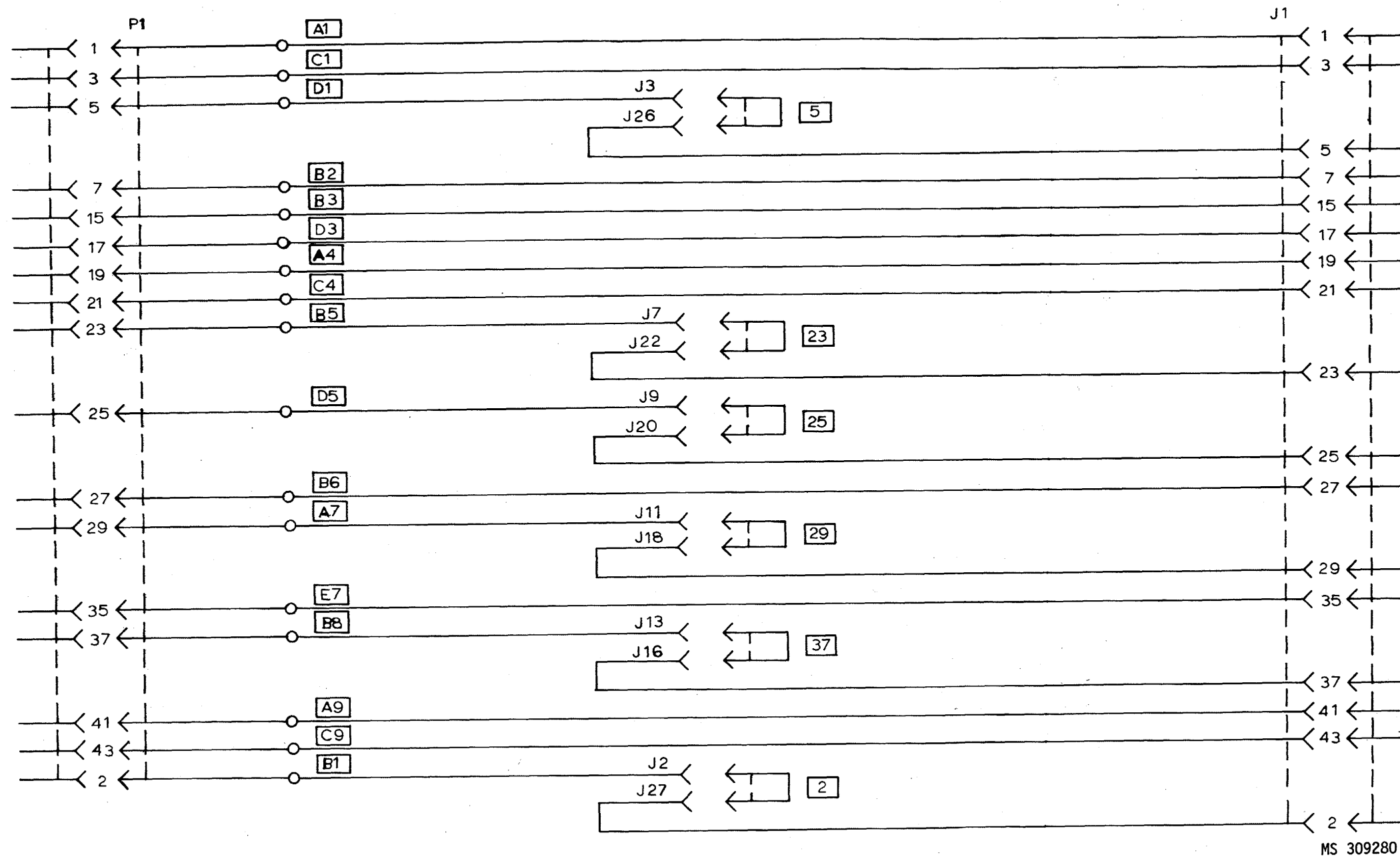

Figure 3-196. Test adapter TA8-1021 10292827 (FG 4210)-schematic (sheet 1 of 2)
3-250

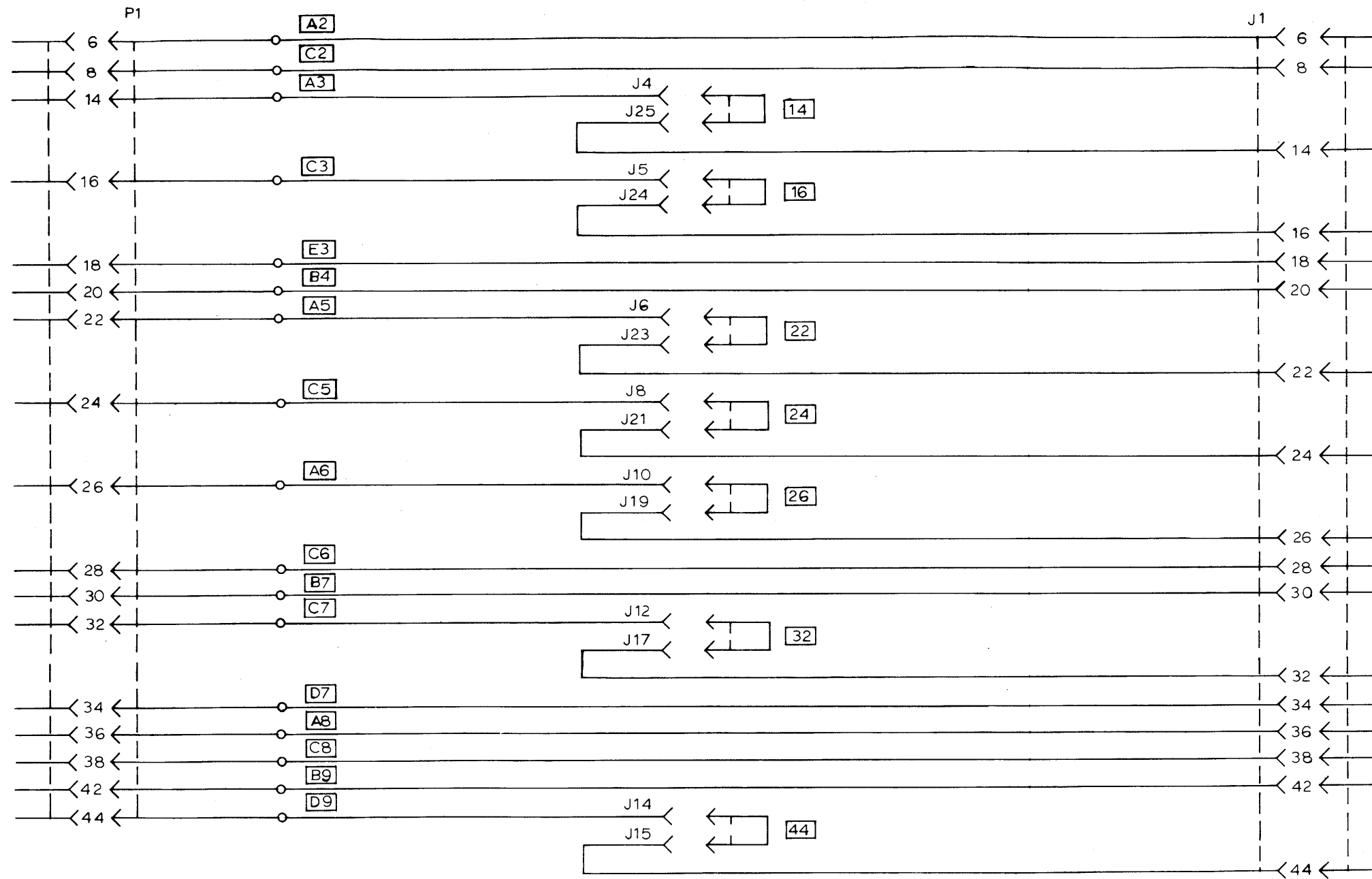
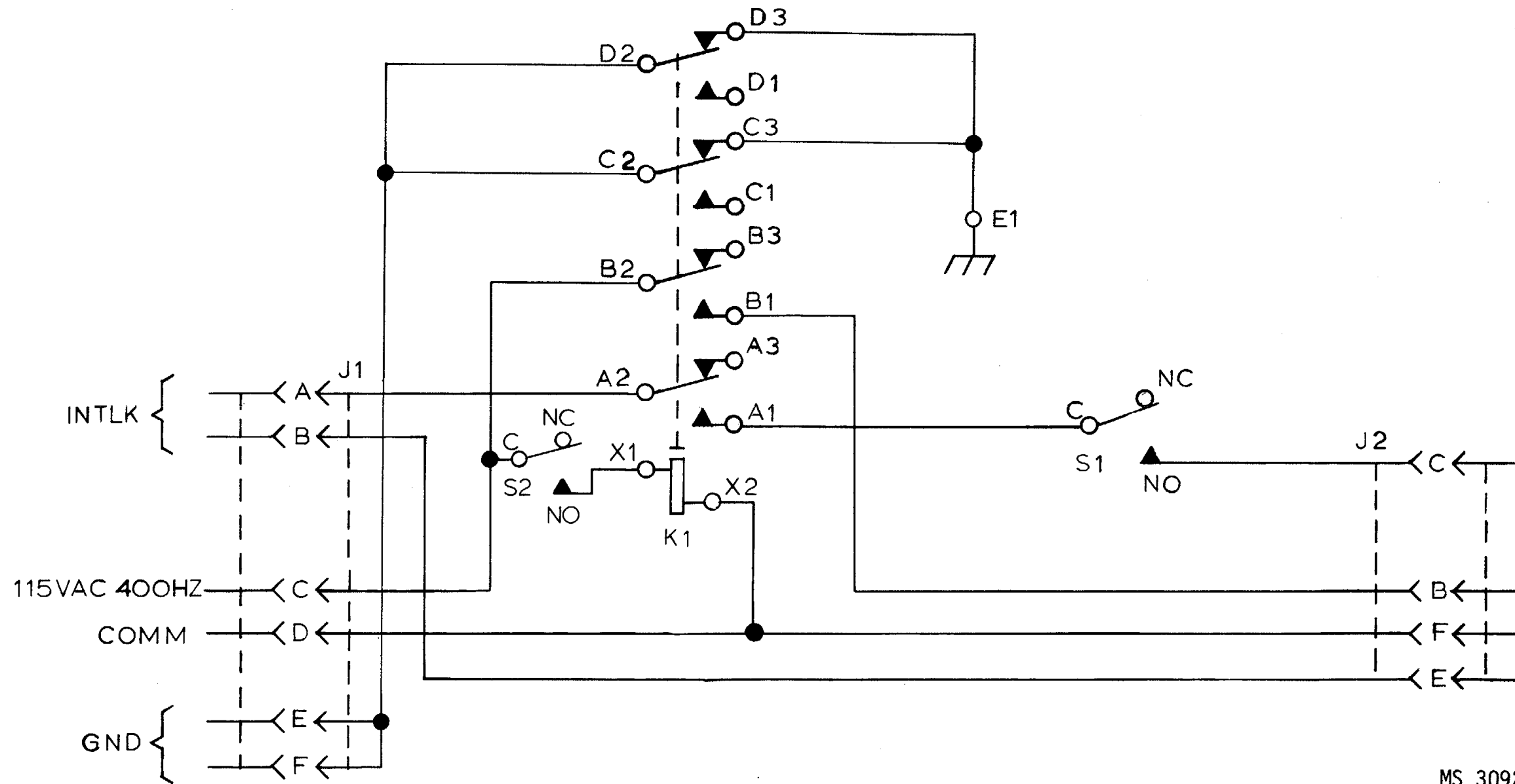

Figure 3-196. Test adapter TA8-1021 10292827 (FG 4210)-schematic (sheet 2 of 2)
3-251



MS 309282

Figure 3-197. Test adapter TA8-1022 11565938 (FG 4300)-schematic.
3-252

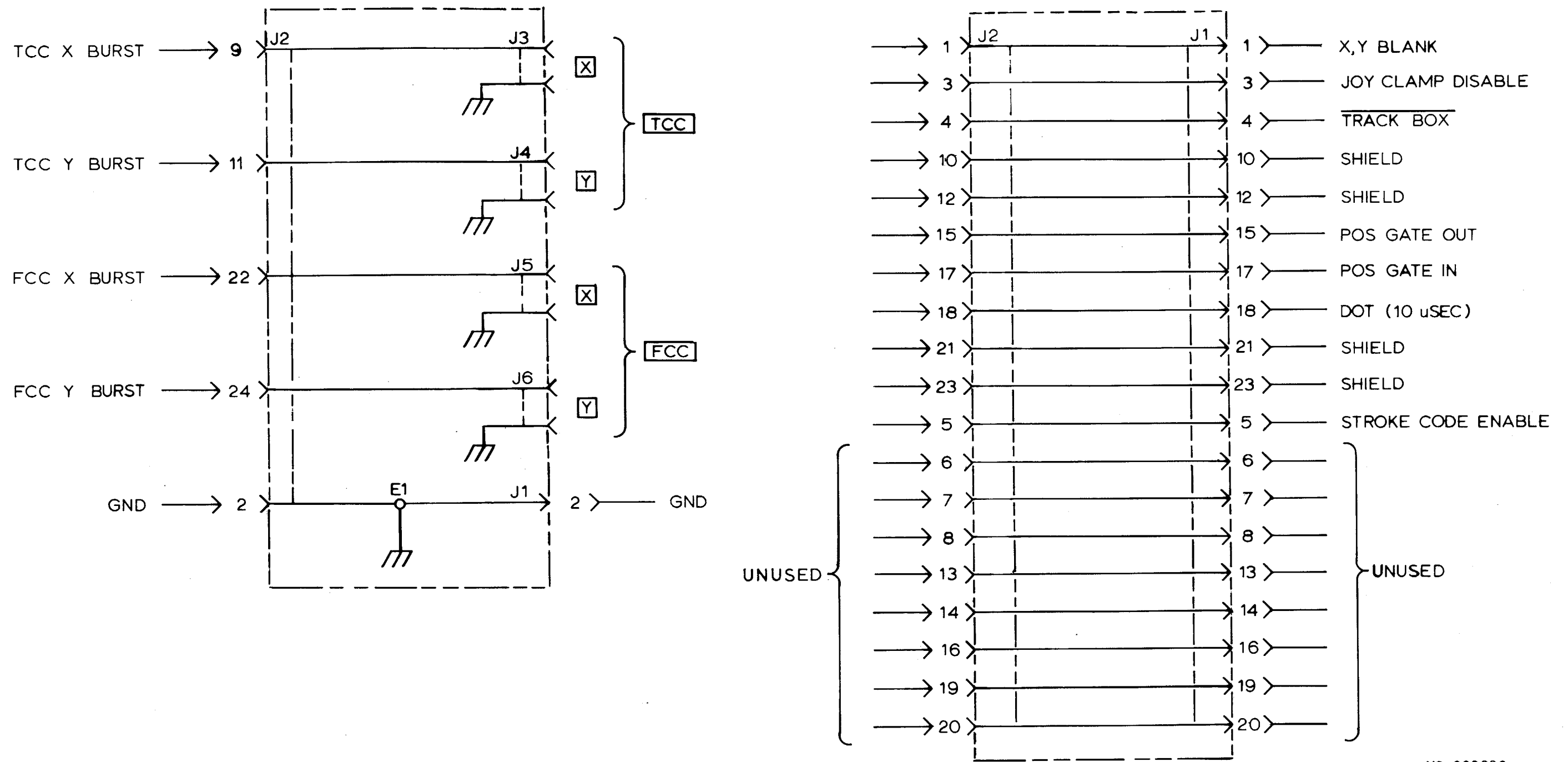

Figure 3-198. Test adapter TA8-1023 11566026 (FG 4360) schematic

MS 309283

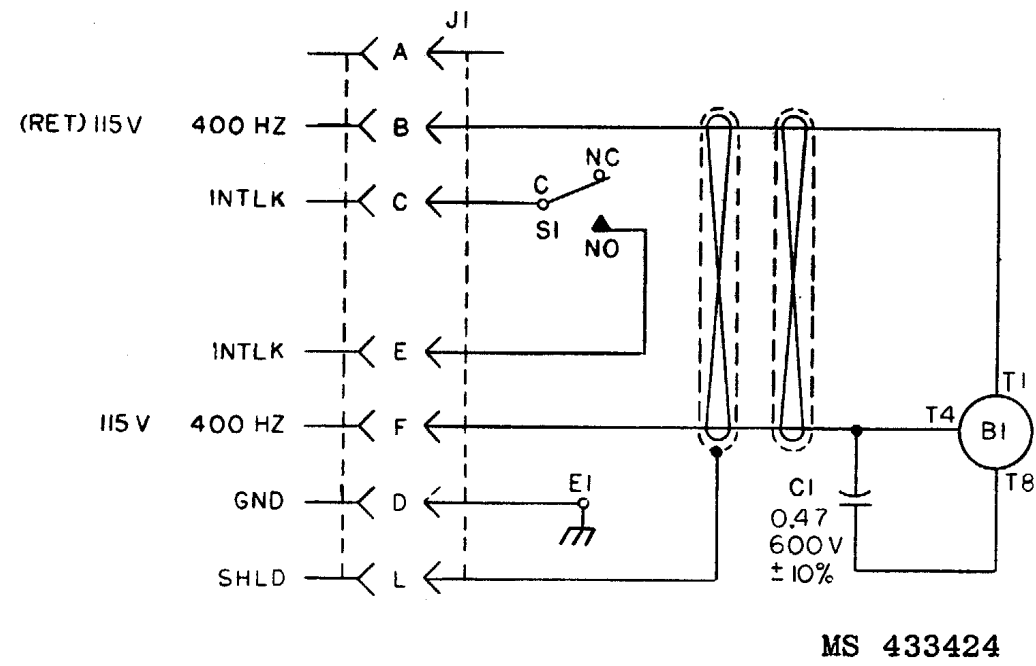

Figure 3-199.1. Test adapter TA8-1028 11570851 *(AE) (see note) (FG 1100) - schematic.

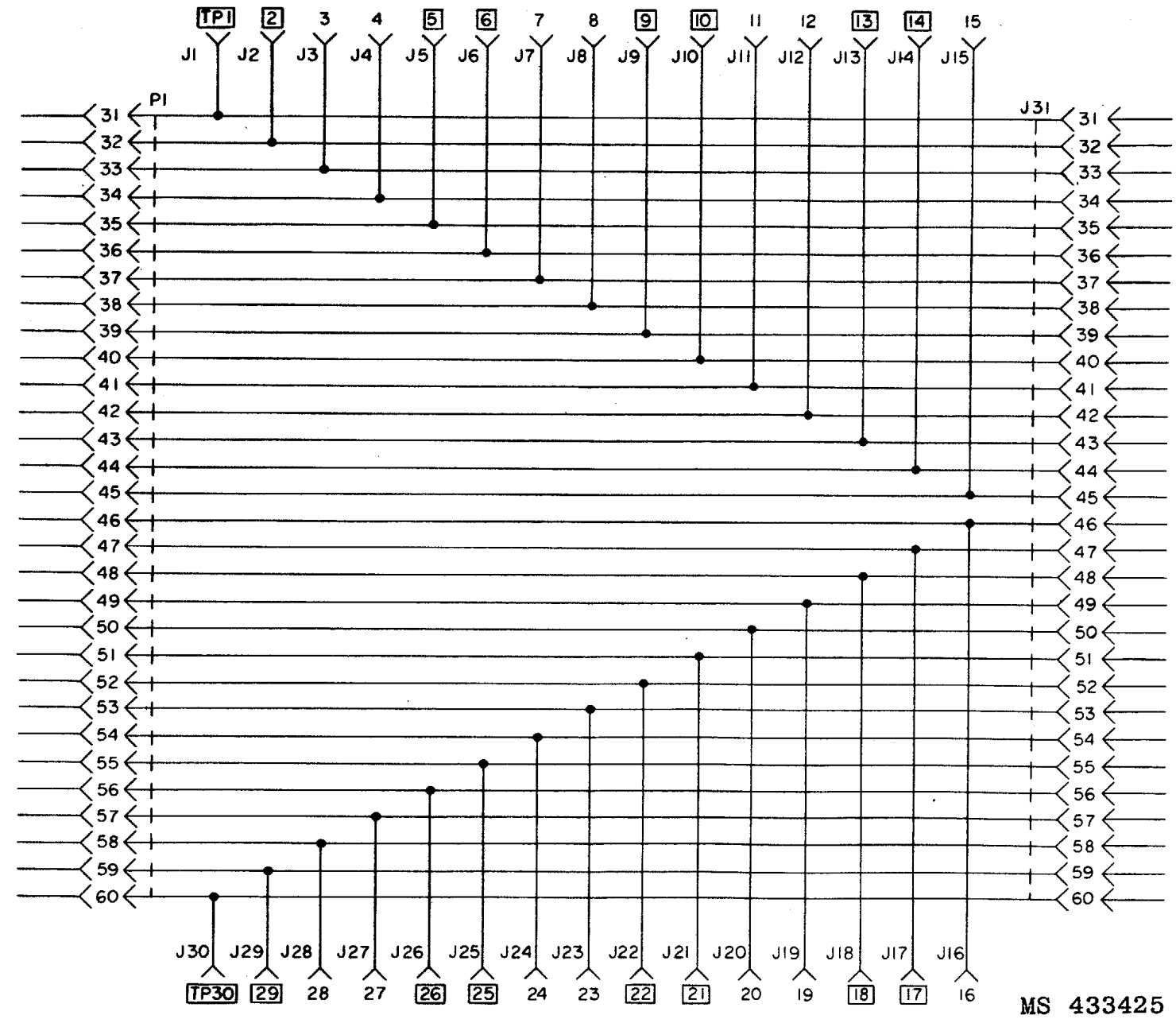

Figure 3-199.2. Test adapter TA8-1029 11570883 *(AF) (see note) (p/o FG 4380) schematic

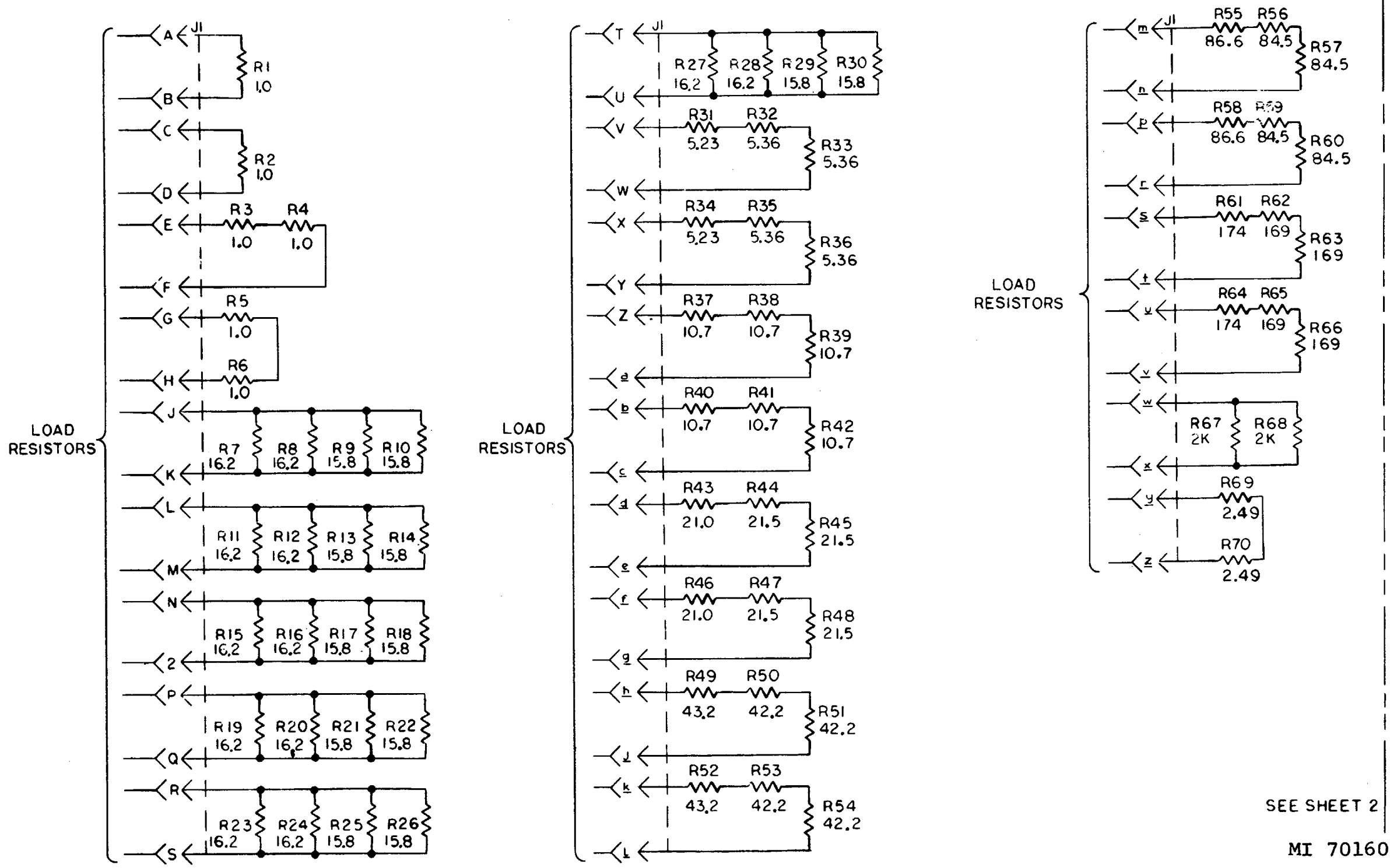
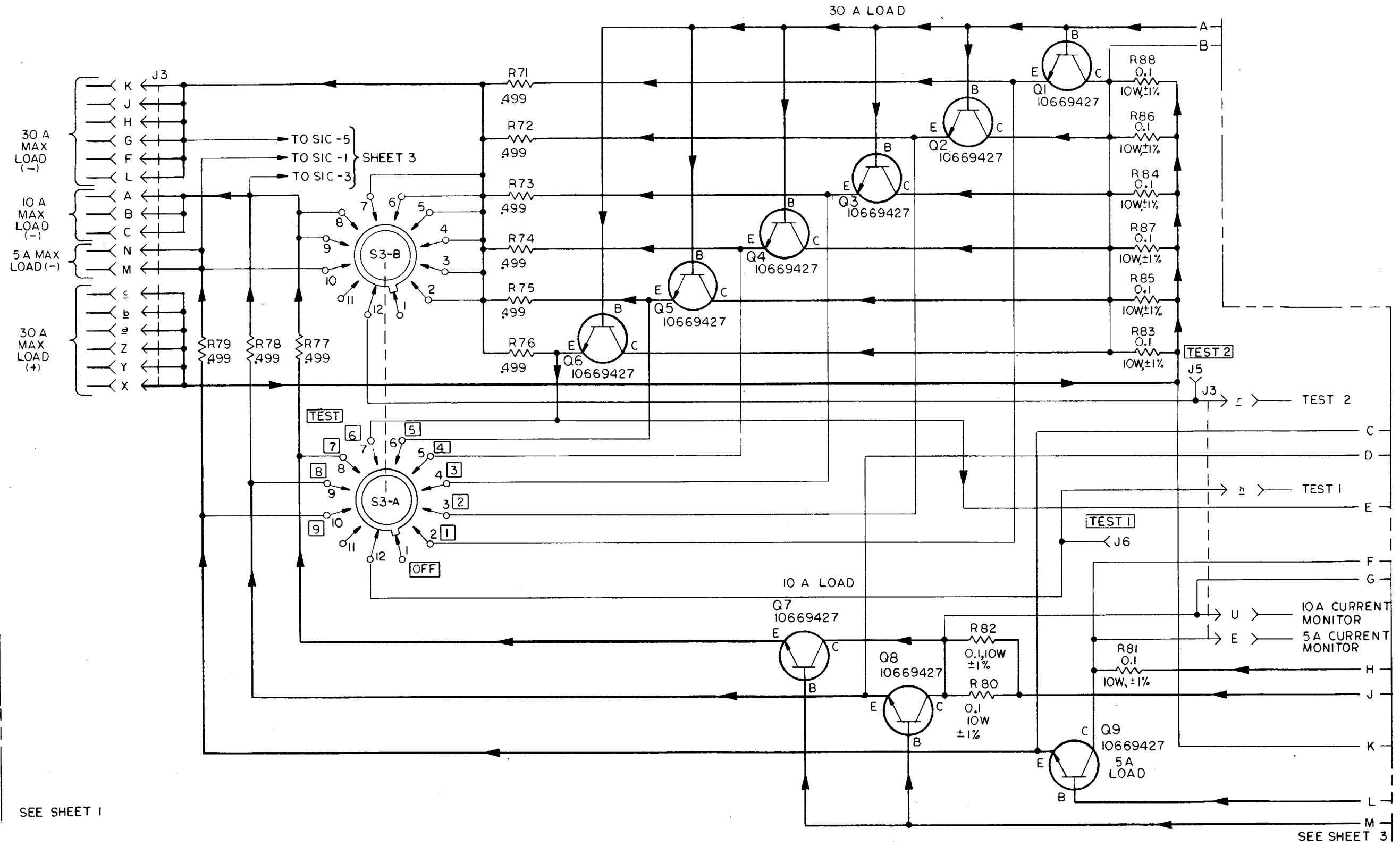

Figure 3-200. Test fixture TF8-103 (universal load box) 10671776 (FG 3660) schematic (sheet 1 of 4)

SEE SHEET 2
MI 70160



SEE SHEET 1

SEE SHEET 3

MI 70161

Figure 3-200. Test fixture TF8-103 (universal load box) 10671776 (FG 3660) schematic (sheet 2 of 4)

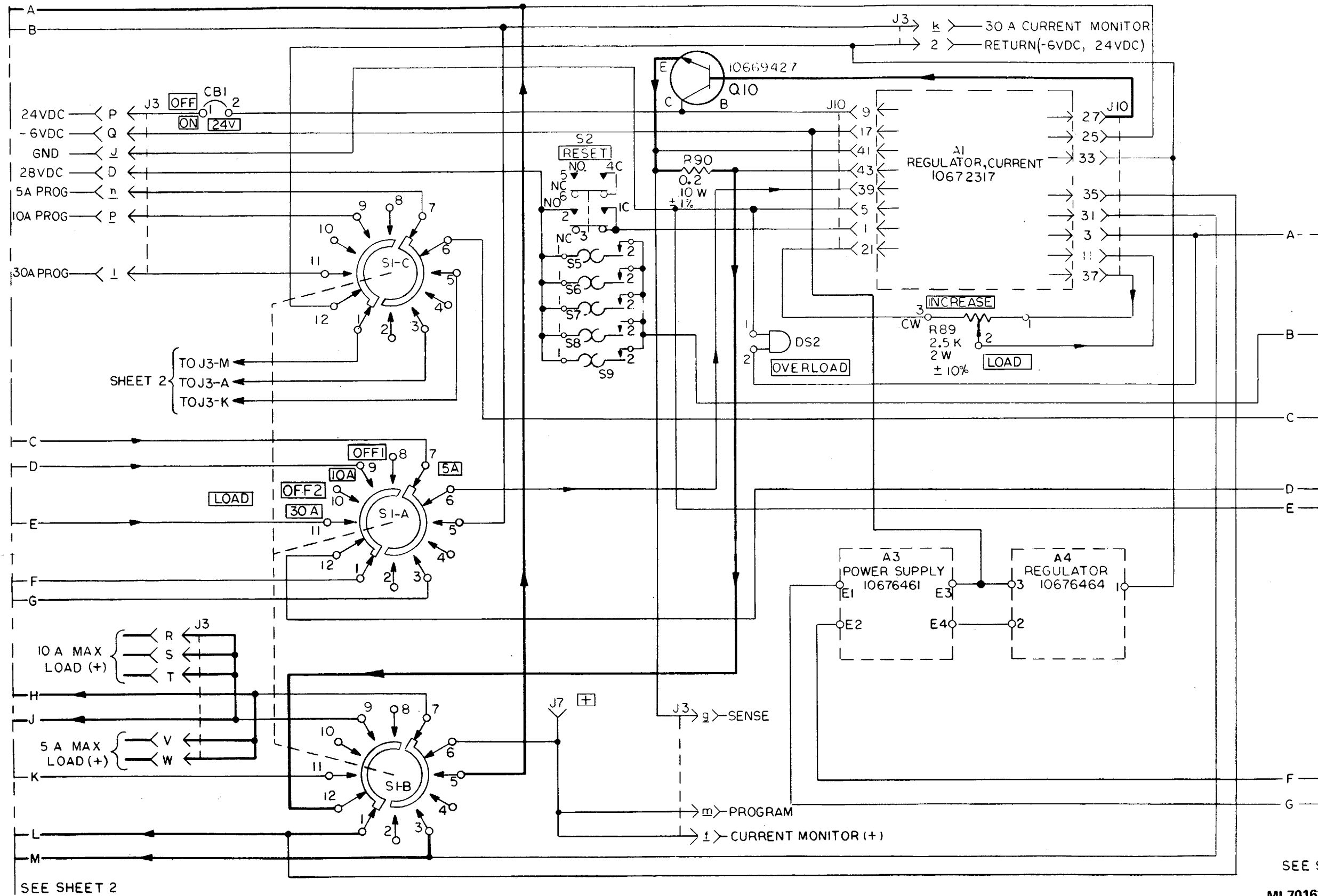
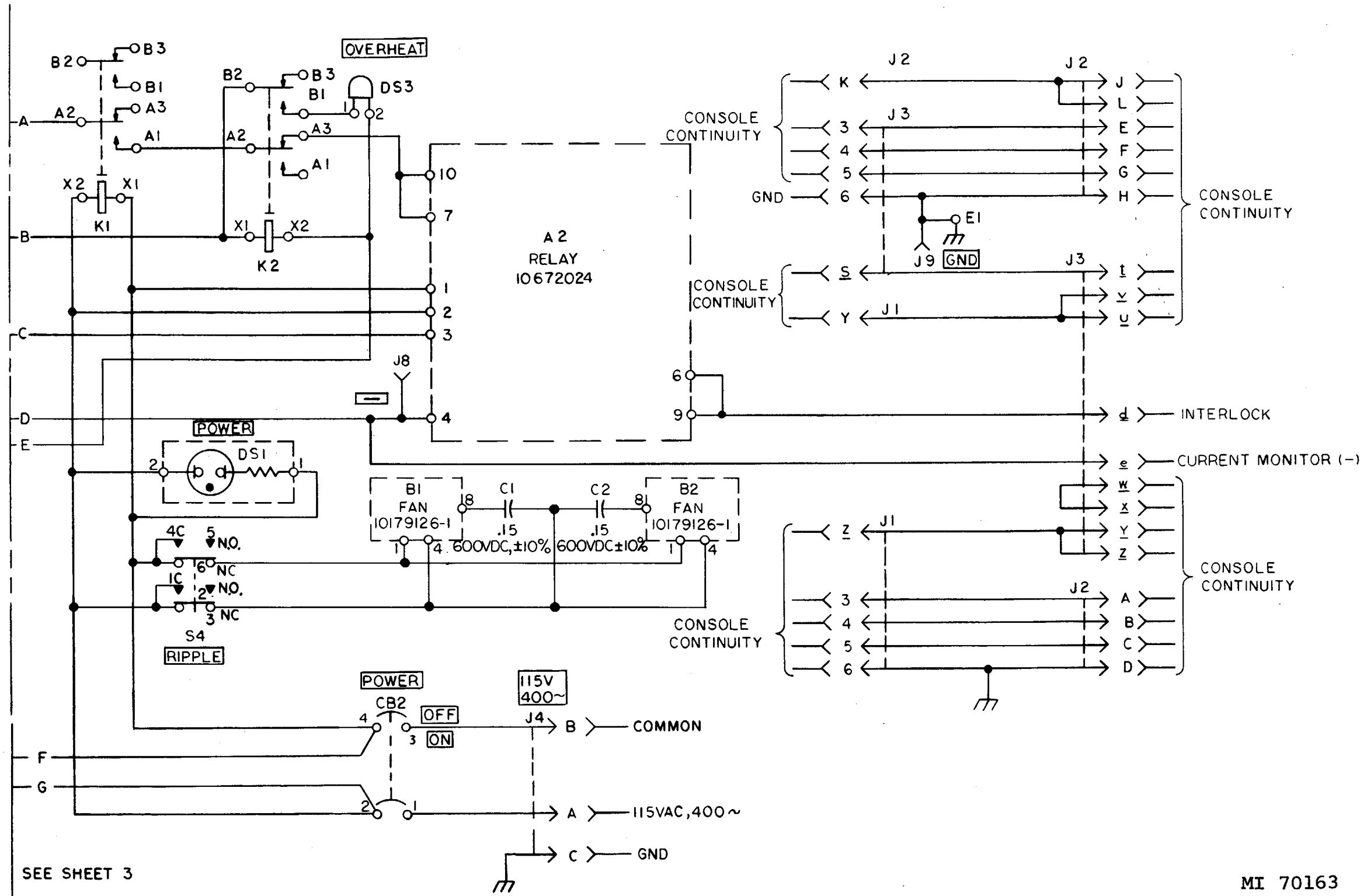

Figure 3-200. Test fixture TF8-103 (universal load box) 10671776 (FG 3660) schematic (sheet 3 of 4)

SEE SHEET 4
MI 70162



SEE SHEET 3

MI 70163

Figure 3-200. Test fixture TF8-103 (universal load box) 10671776 (FG 3660) schematic (sheet 4 of 4)

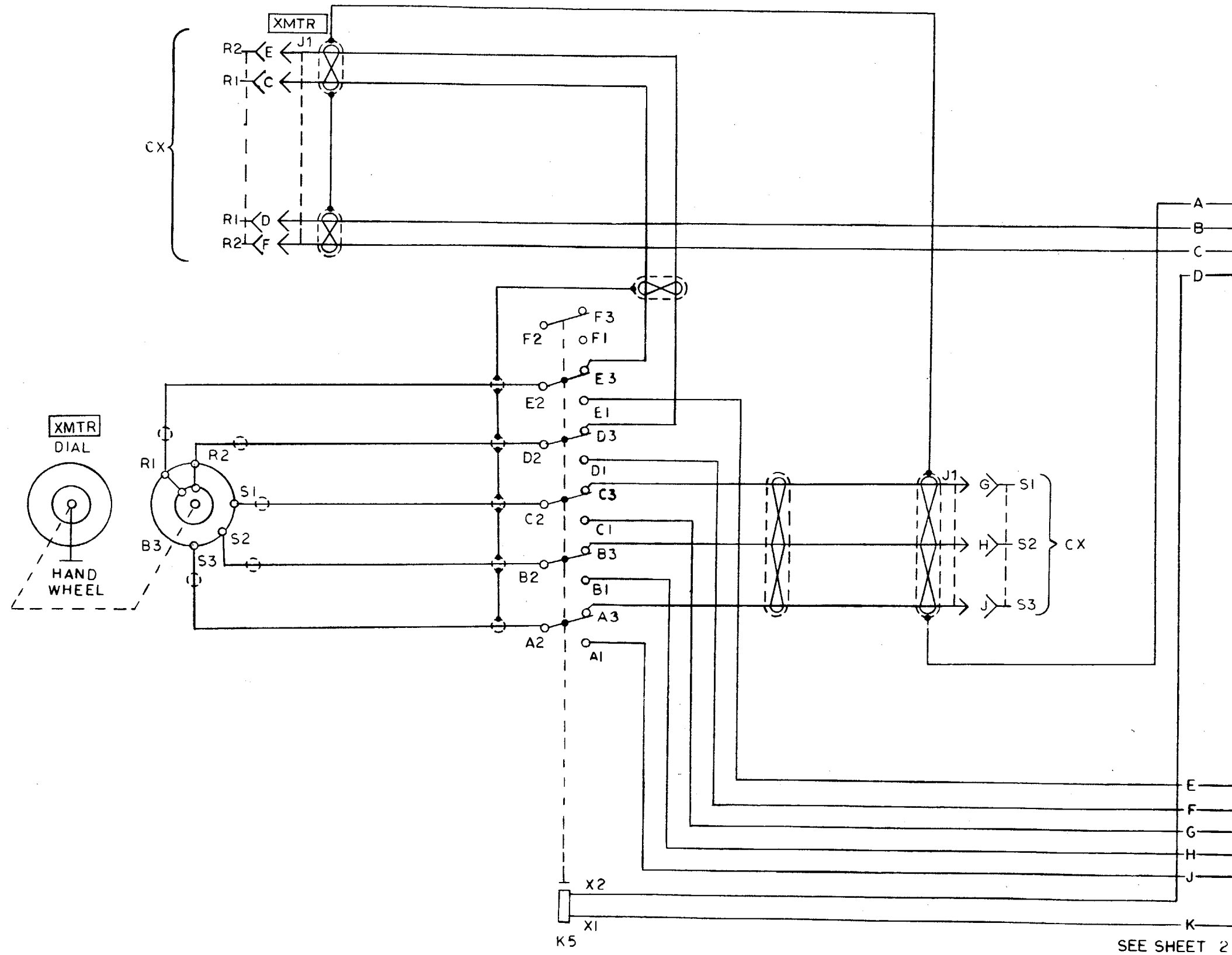

Figure 3-201. Test fixture TF8-106A (synchro test set) 11565960 (FG 3680) schematic (sheet 1 of 4)

MS 309285

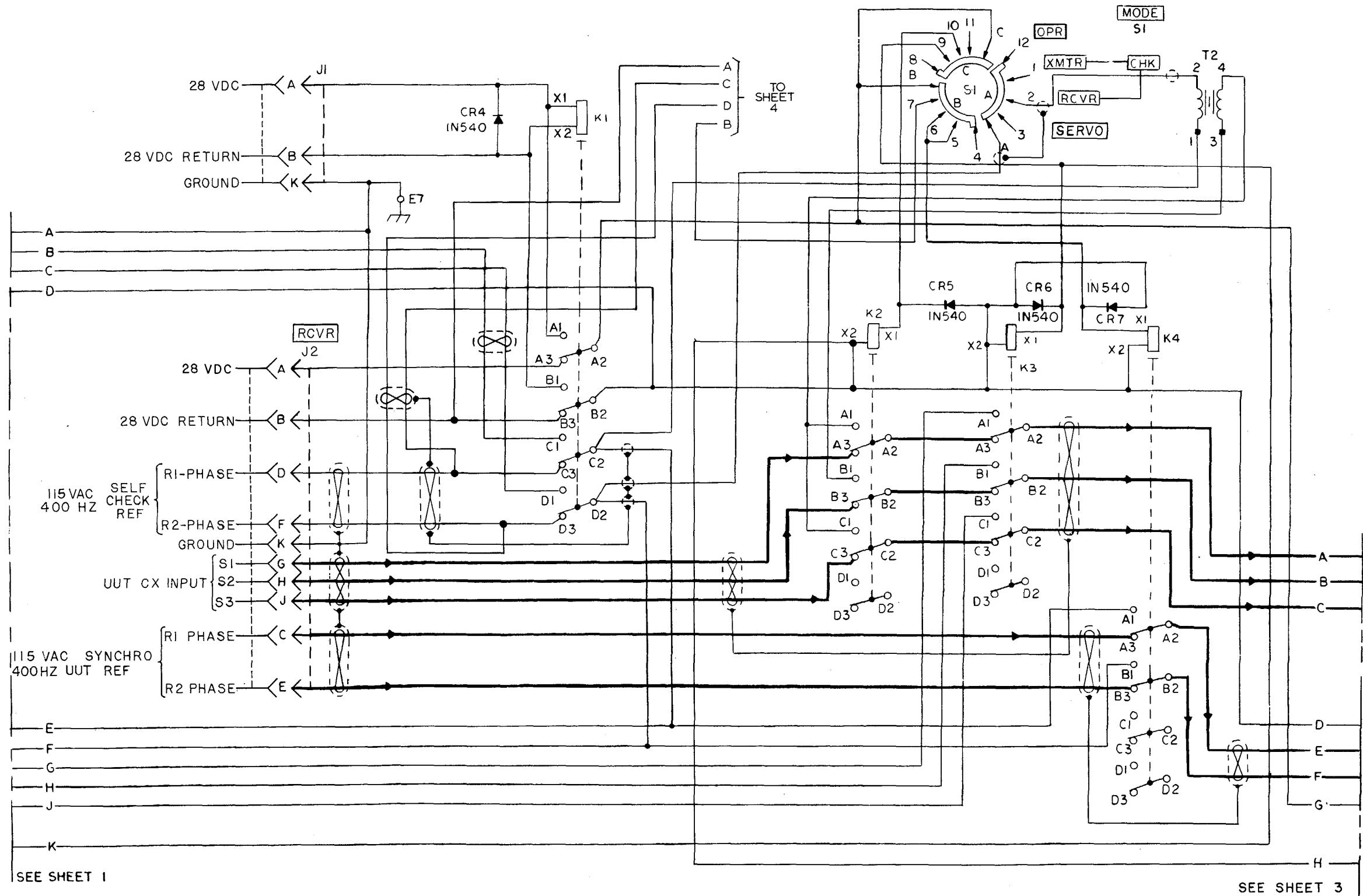

Figure 3-201. Test fixture TF8-106A (synchro test set) 11565960 (FG 3680) schematic (sheet 2 of 4)

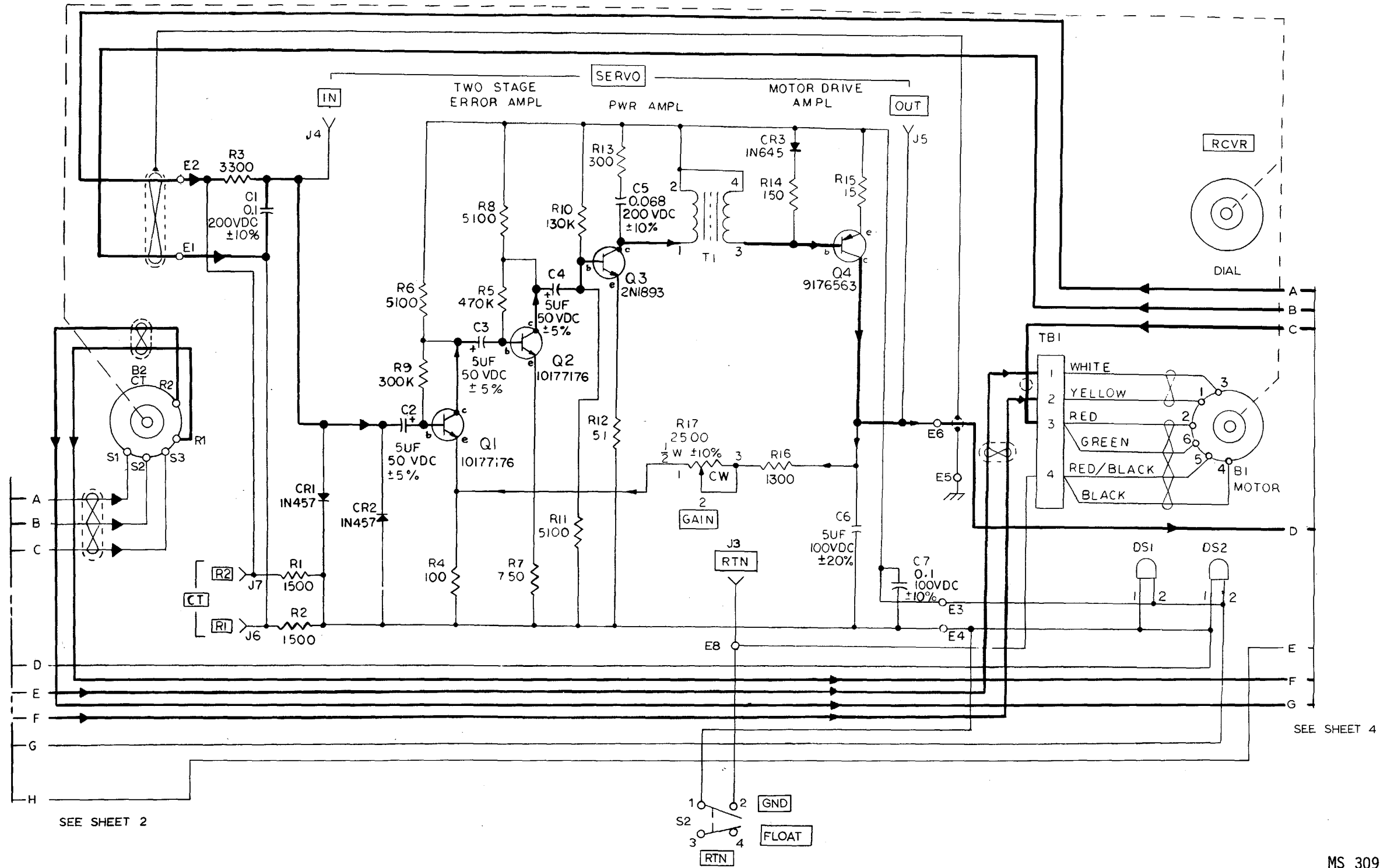

Figure 3-201. Test fixture TF8-106A (synchro test set) 11565960 (FG 3680) schematic (sheet 3 of 4)

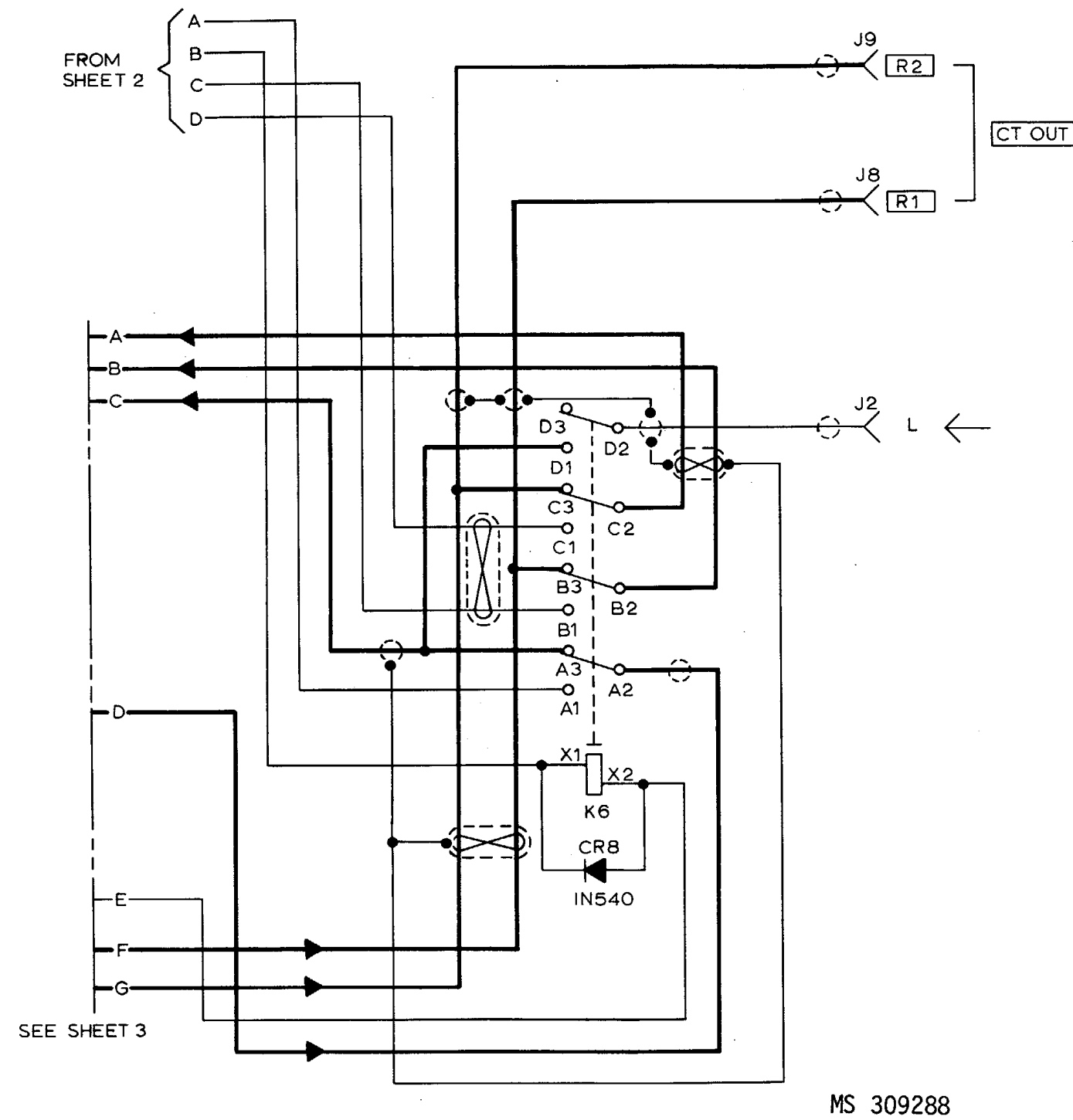

Figure 3-201. Test fixture TF8-106A (synchro test set) 11565960-(FG 3680) - schematic (sheet 4 of 4).

TF8-106 W1

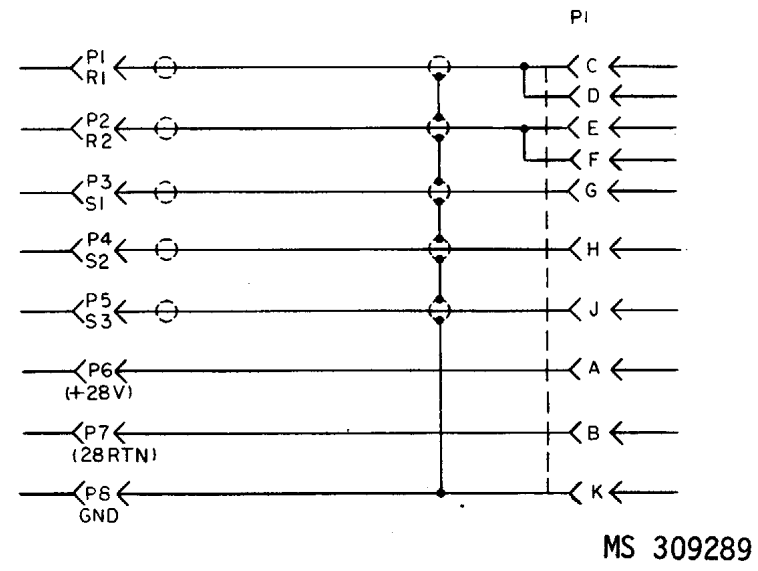

Figure 3-202. Test fixture TF8-106 W1 test cable-schematic.

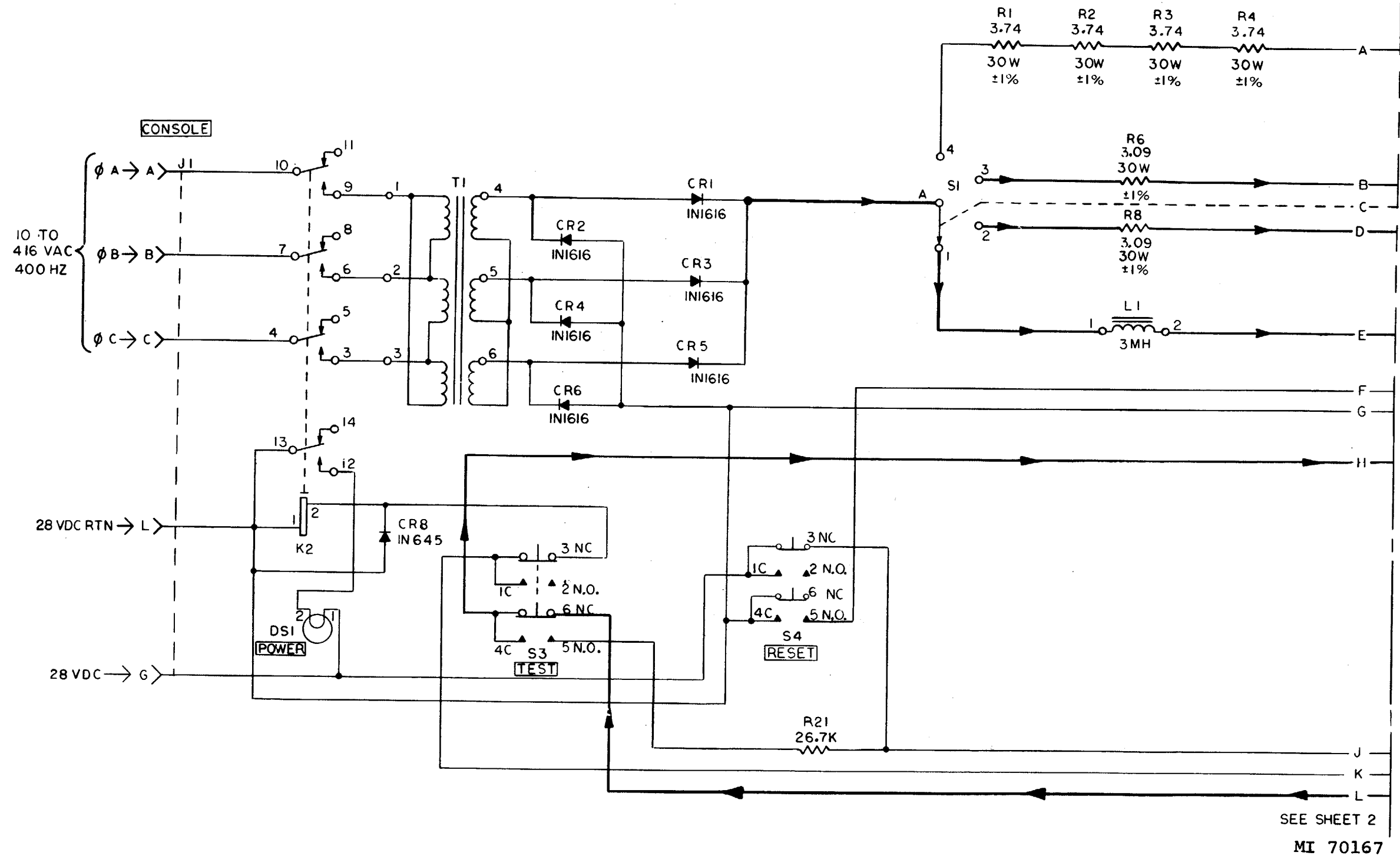
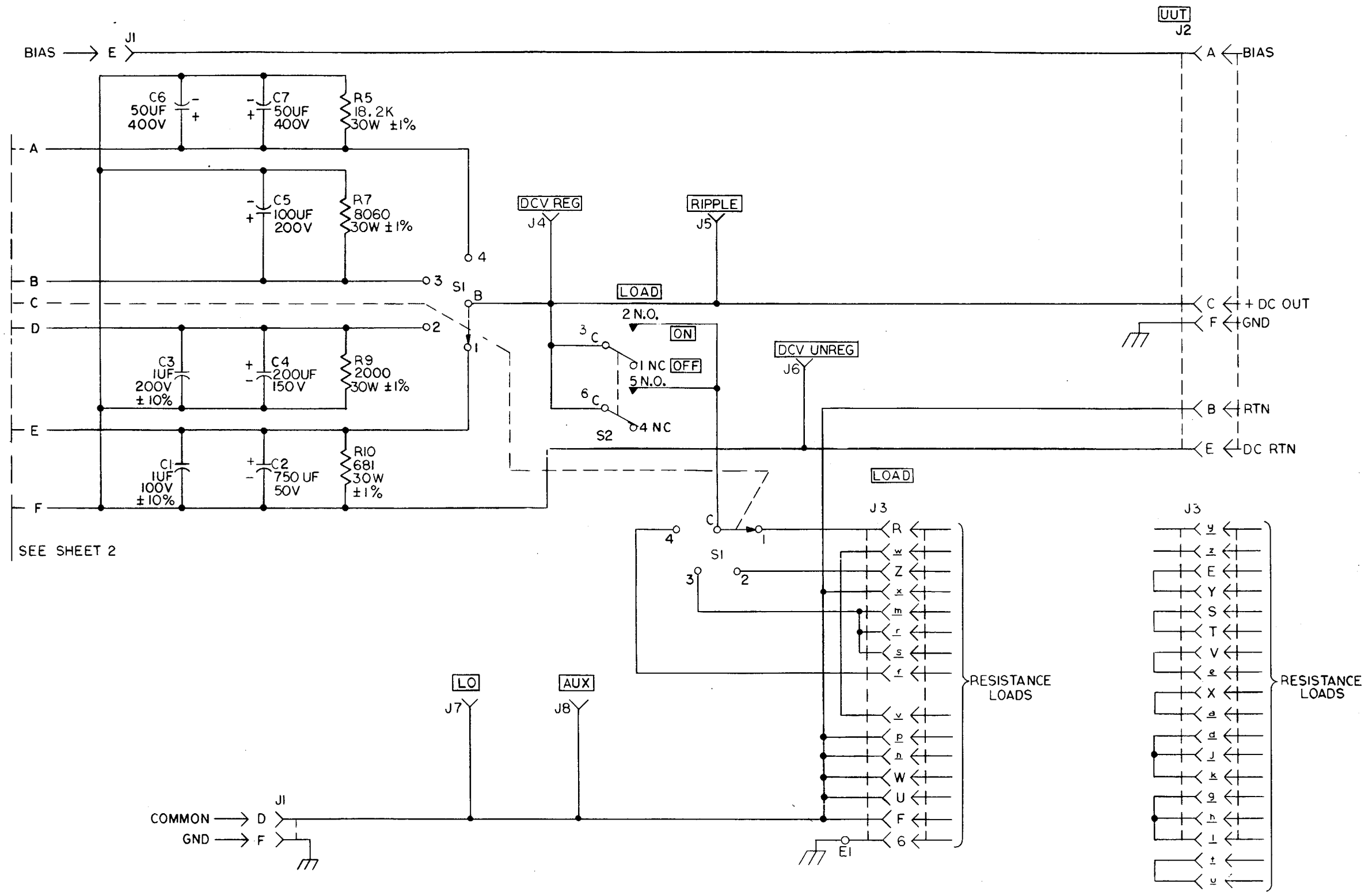

Figure 3-203. Test fixture TF8-106 10671070 (FG 3700)-schematic (sheet 1 of 3).

SEE SHEET 2
MI 70167



MI 70169

Figure 3-203. Test fixture TF8-109 10671070 (FG 3700)- schematic (sheet 3 of 3).

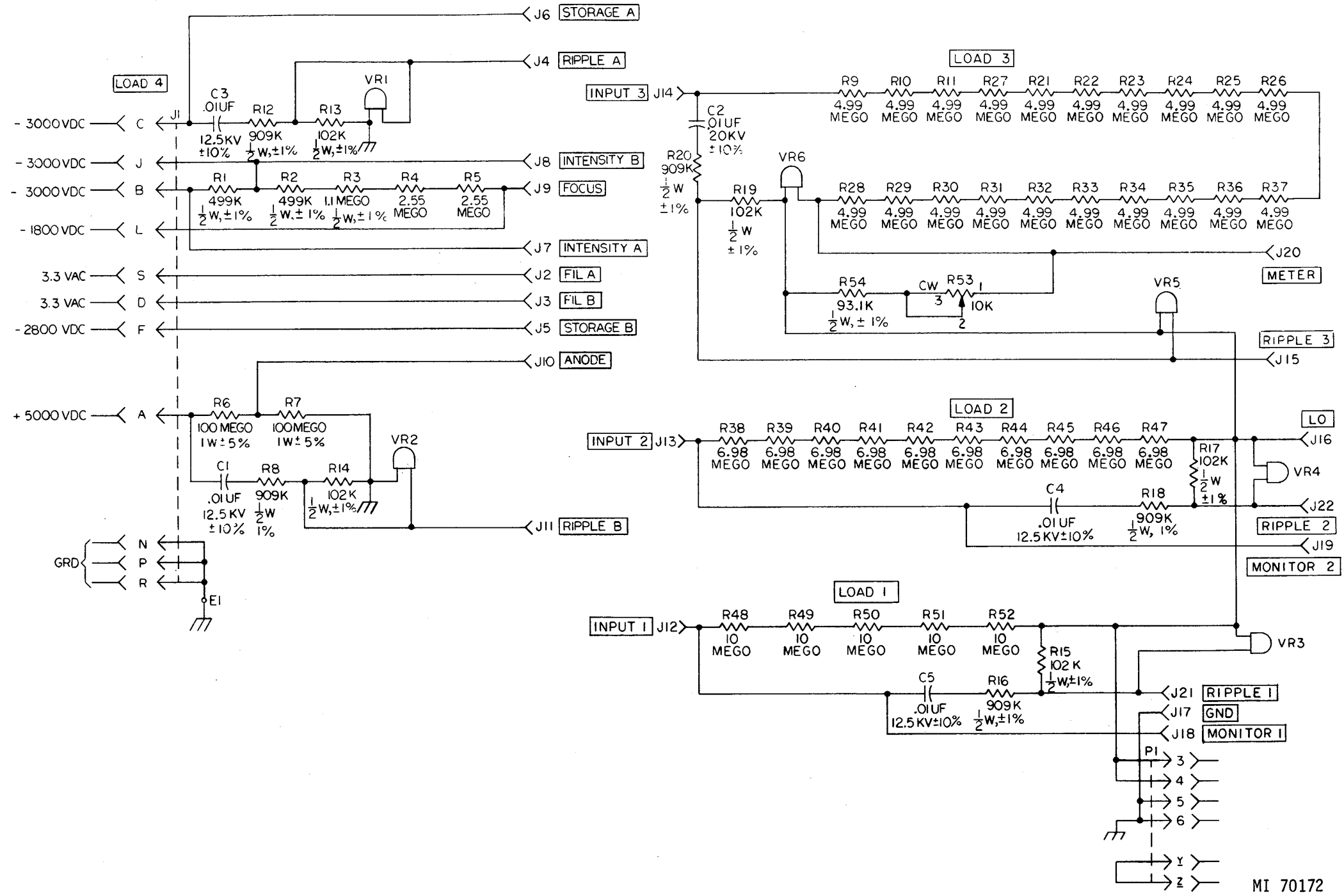
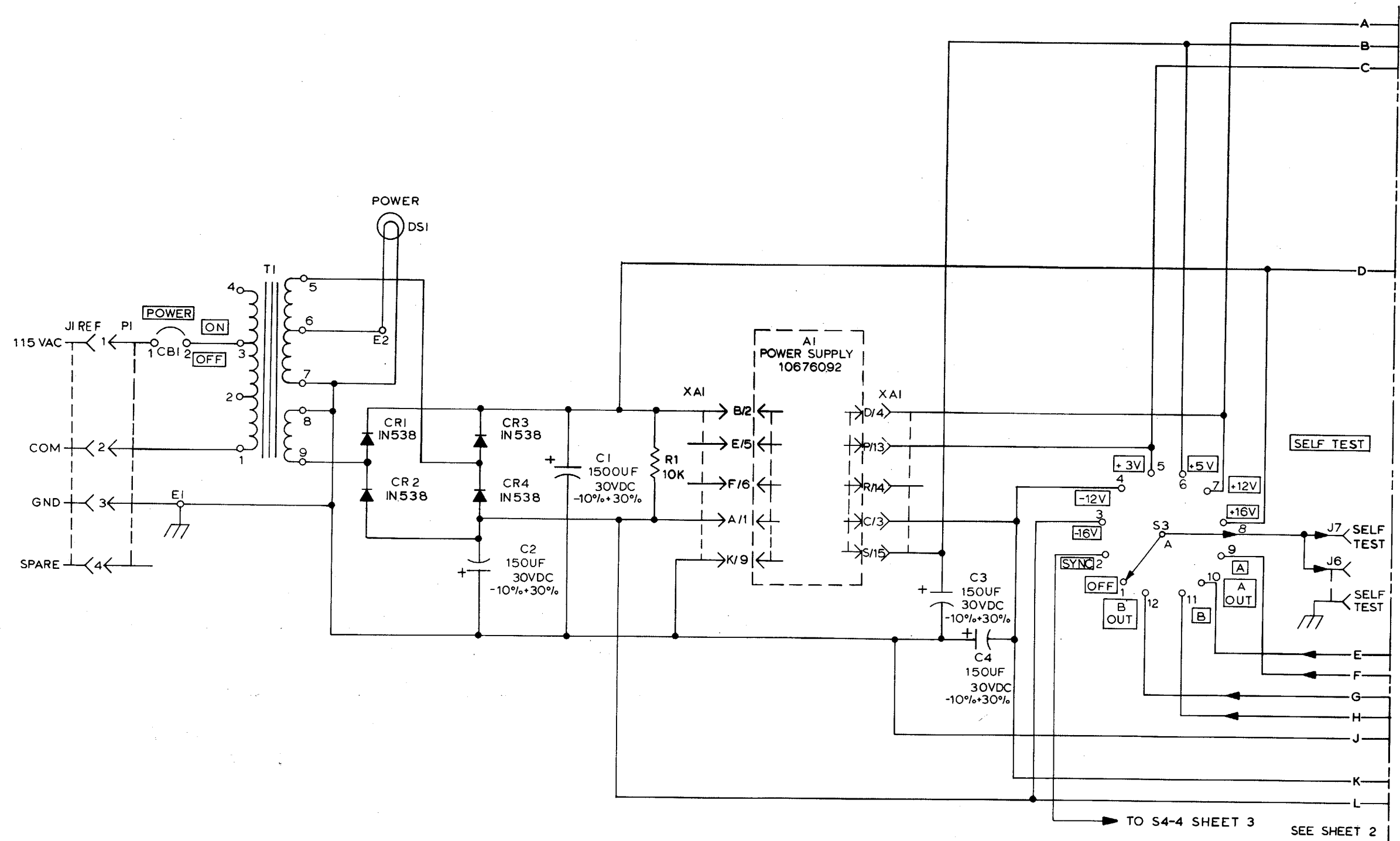
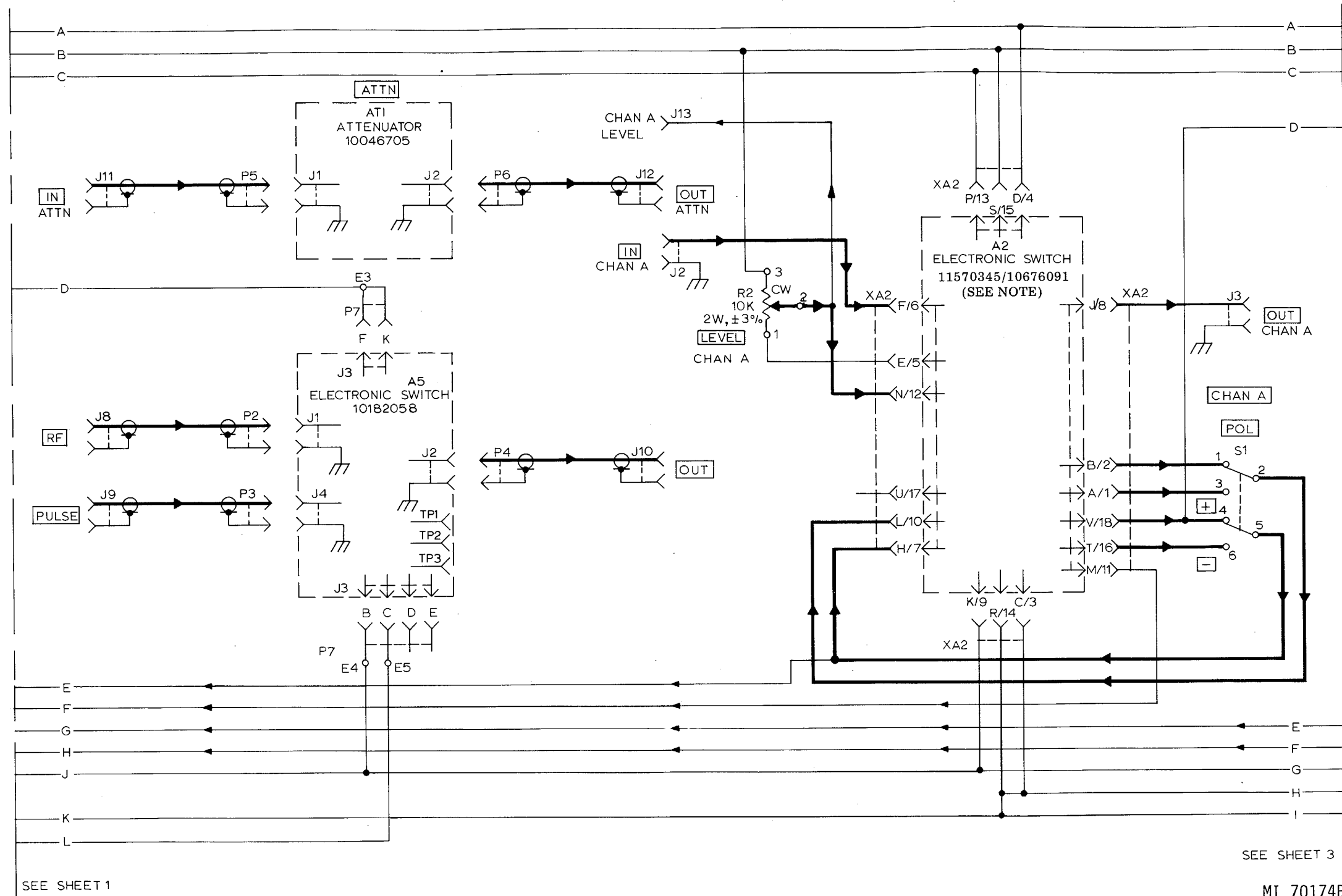

Figure 3-204. Test fixture TF8-1011 10671777 (FG 3740)-schematic.



MI 70173

Figure 3-205. Test fixture TF8-1013 (electronic switch group) 10675949 (FG 3845) - schematic (sheet 1 of 3).



NOTE. ELECTRONIC SWITCH (A2) 11570345 REPLACES 10676091 BY ATTRITION.

Figure 3-205. Test fixture TF8-1013 (electronic switch group) 10675949 (FG 3845) - schematic (sheet 2 of 3).

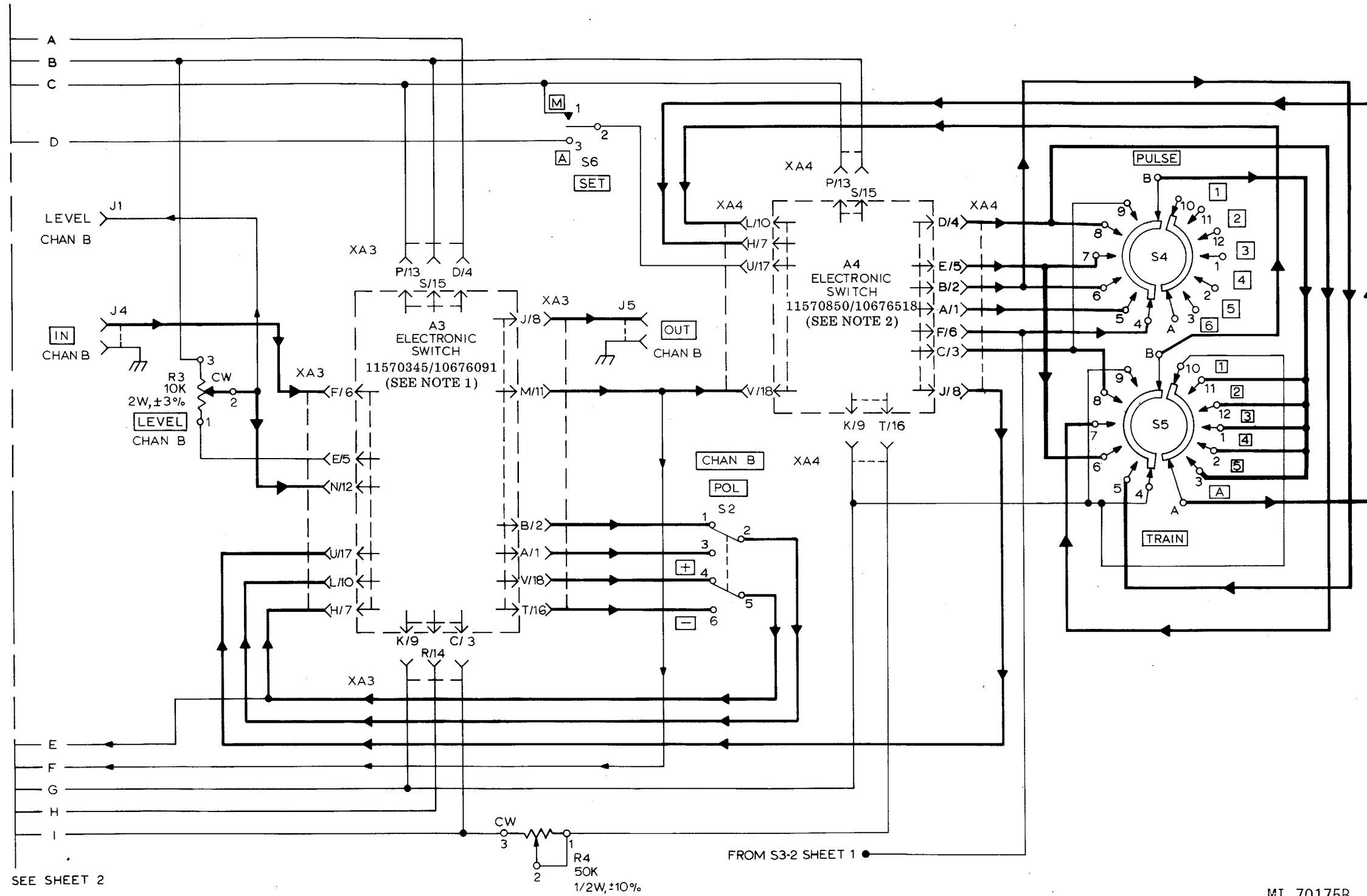

- NOTES: 1. ELECTRONIC SWITCH (A3) 11570345 REPLACES 10676091 BY ATTRITION.
 2. ELECTRONIC SWITCH (AA) 11570850 REPLACES 10676518 BY ATTRITION.

Figure 3-205. Test fixture TF8-1013 (electronic switch group) 10675949 (FG 3845) - schematic (sheet 3 of 3).

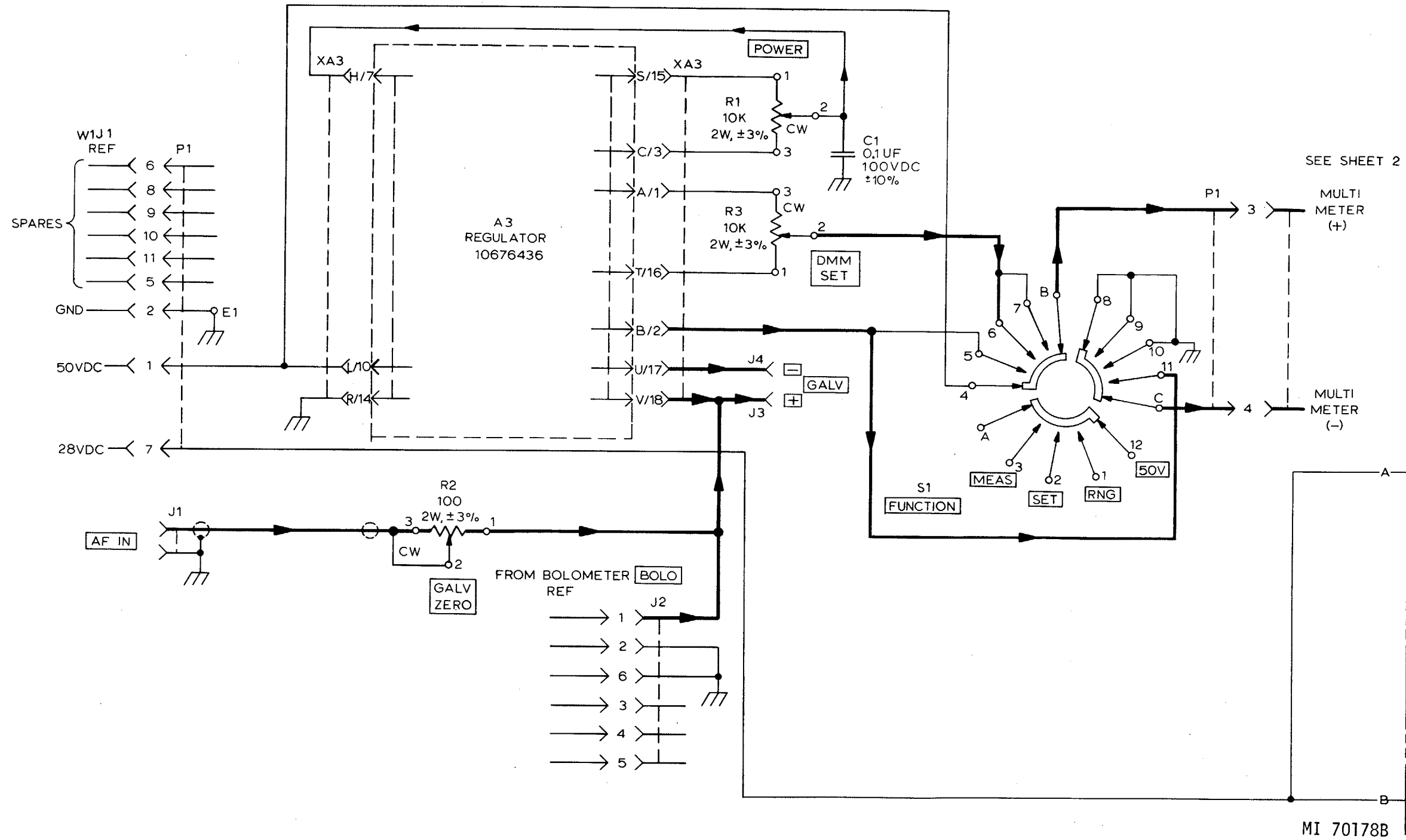

Figure 3-206. Test fixture TF8-1014A (rf power test set group) 10669035 (FG 3835) - schematic.

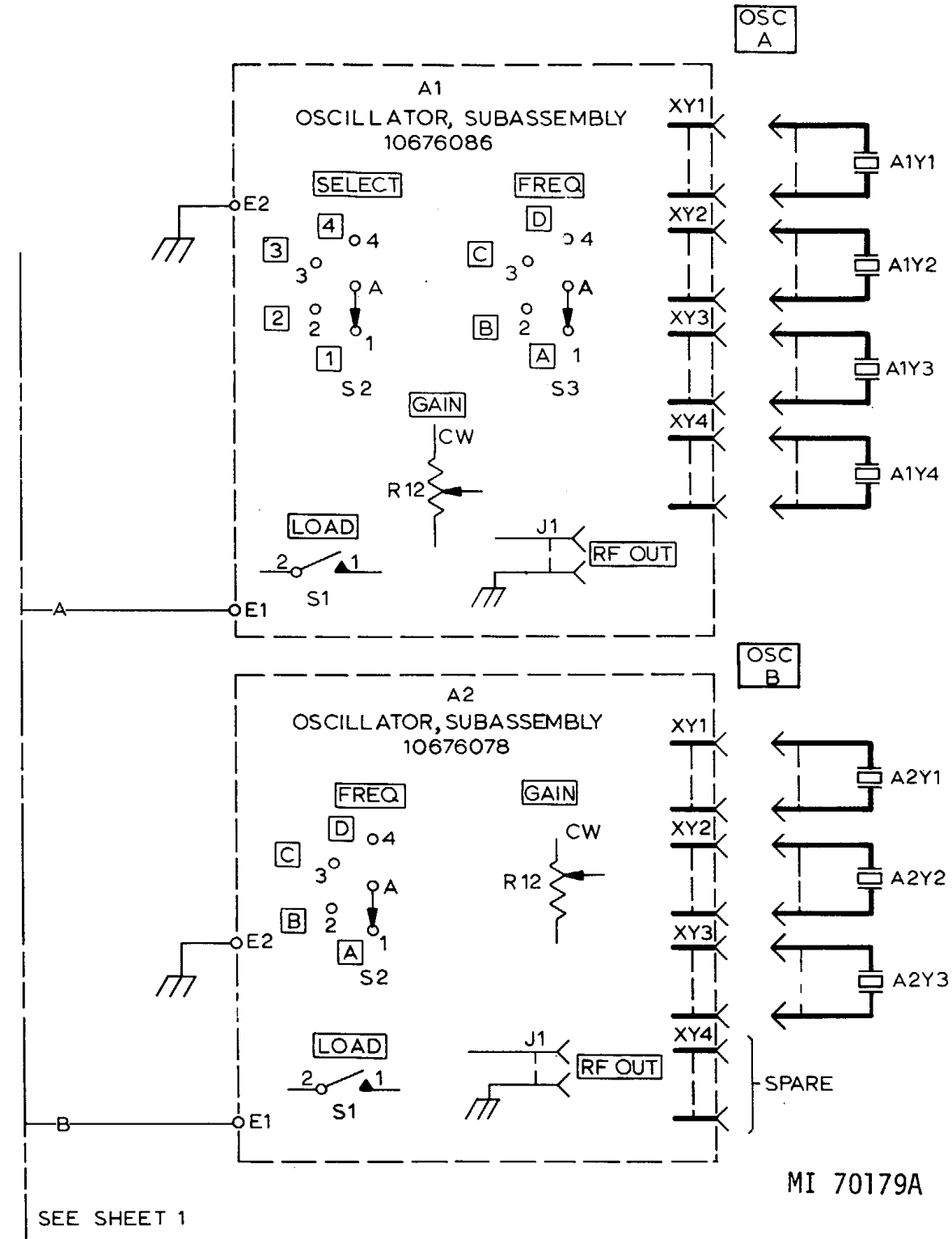
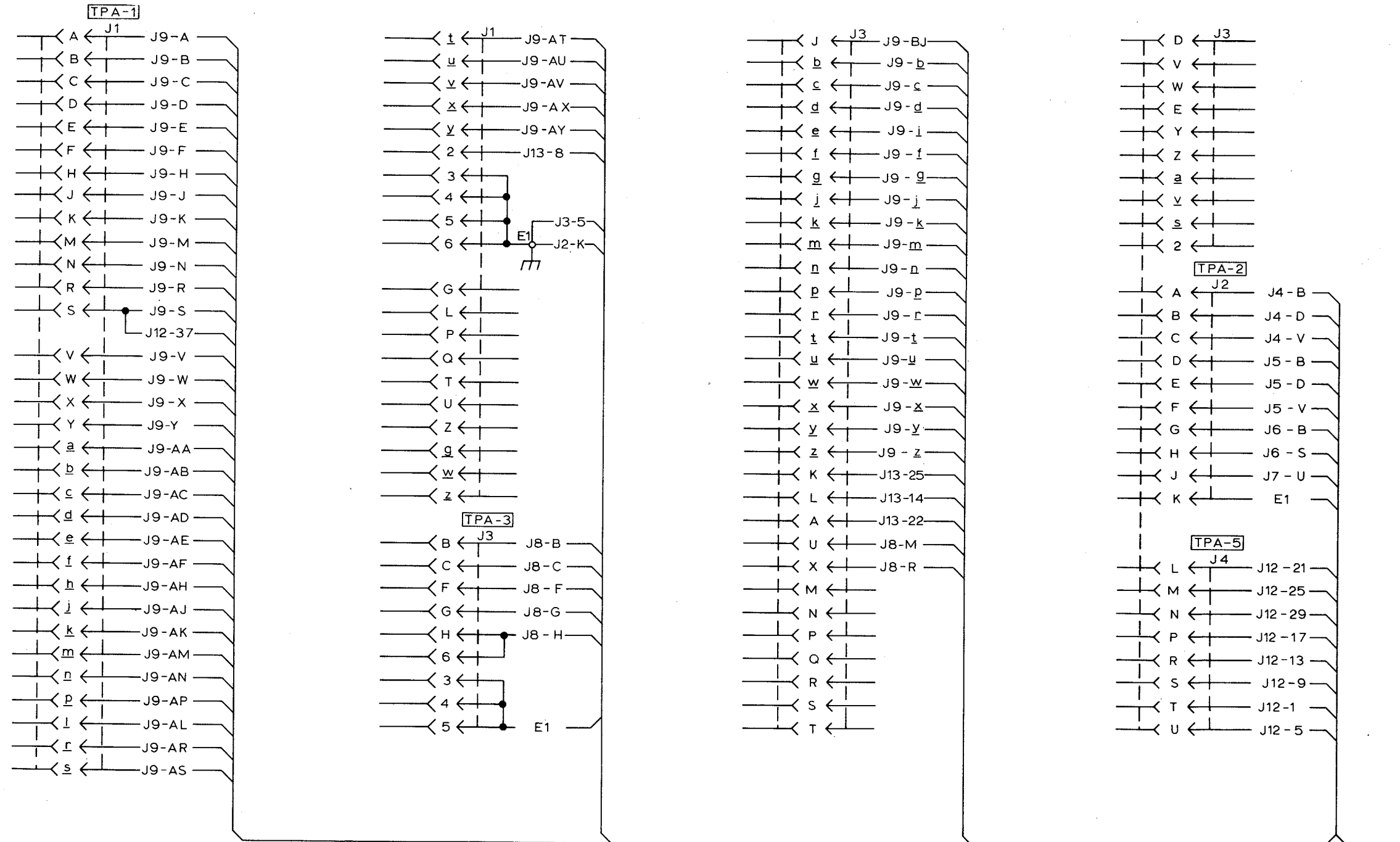

Figure 3-206. Test fixture TF8-1014A (rf power test set group) 10669035 (FG 3835)-schematic (Sheet 2 of 2)
3-281



SEE SHEET 2

MI 70187

Figure 3-207. Test fixture TF8-1016 10677234 (FG 3900) schematic (Sheet 1 of 6)
3-282

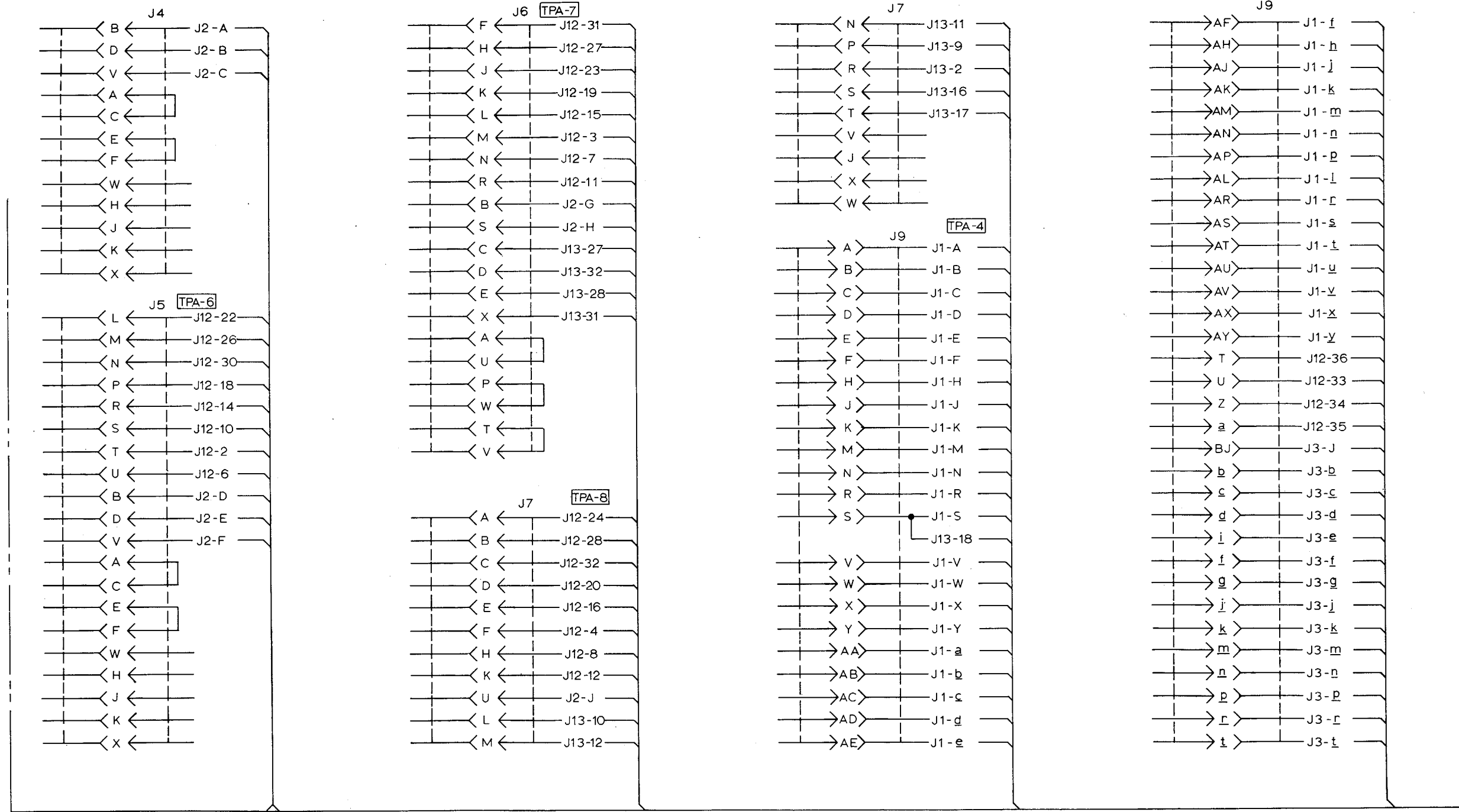

SEE SHEET 1

SEE SHEET 3

MI 70188

Figure 3-207. Test fixture TF8-1016 10677234 (FG 3900) schematic (Sheet 2 of 6)
3-283

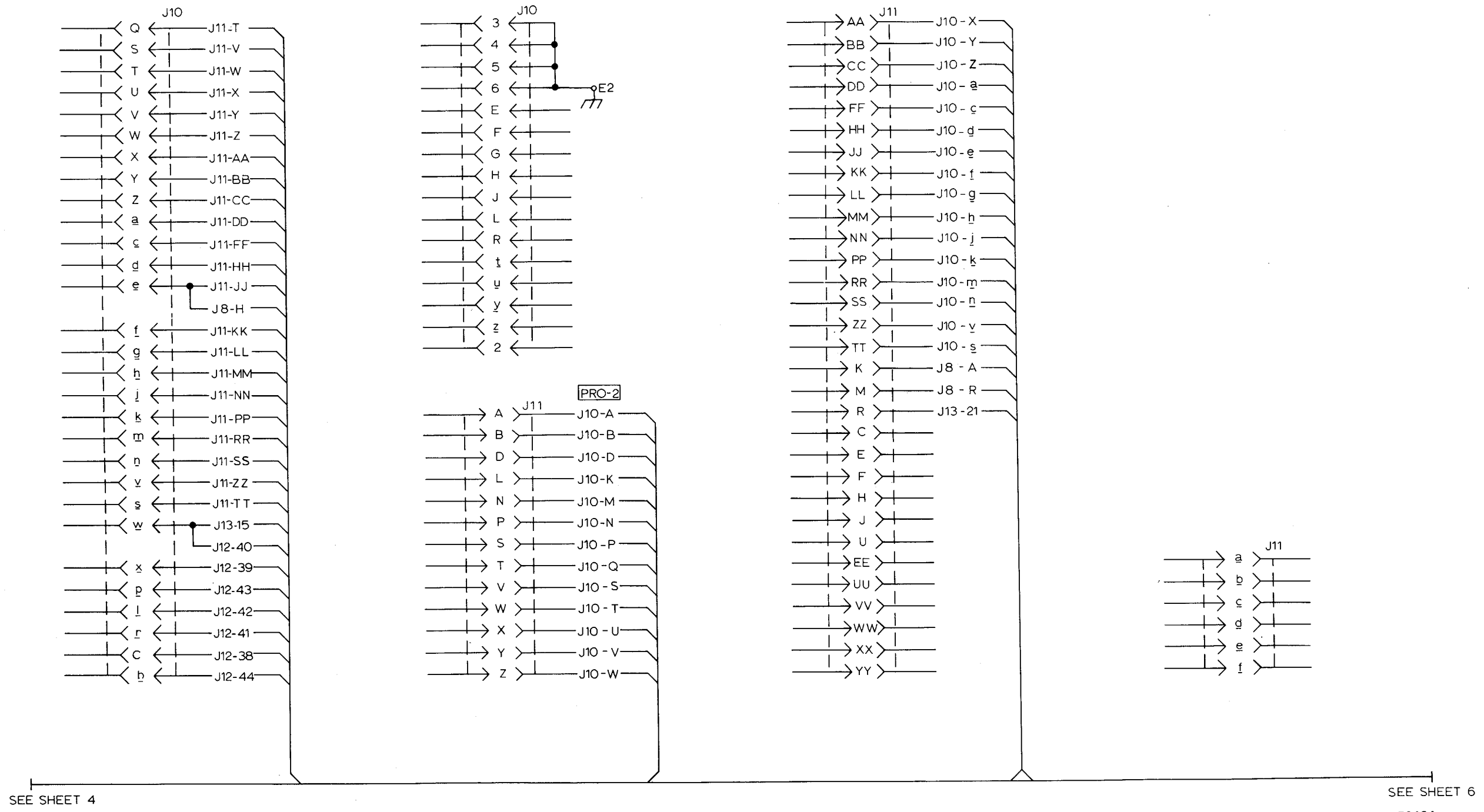
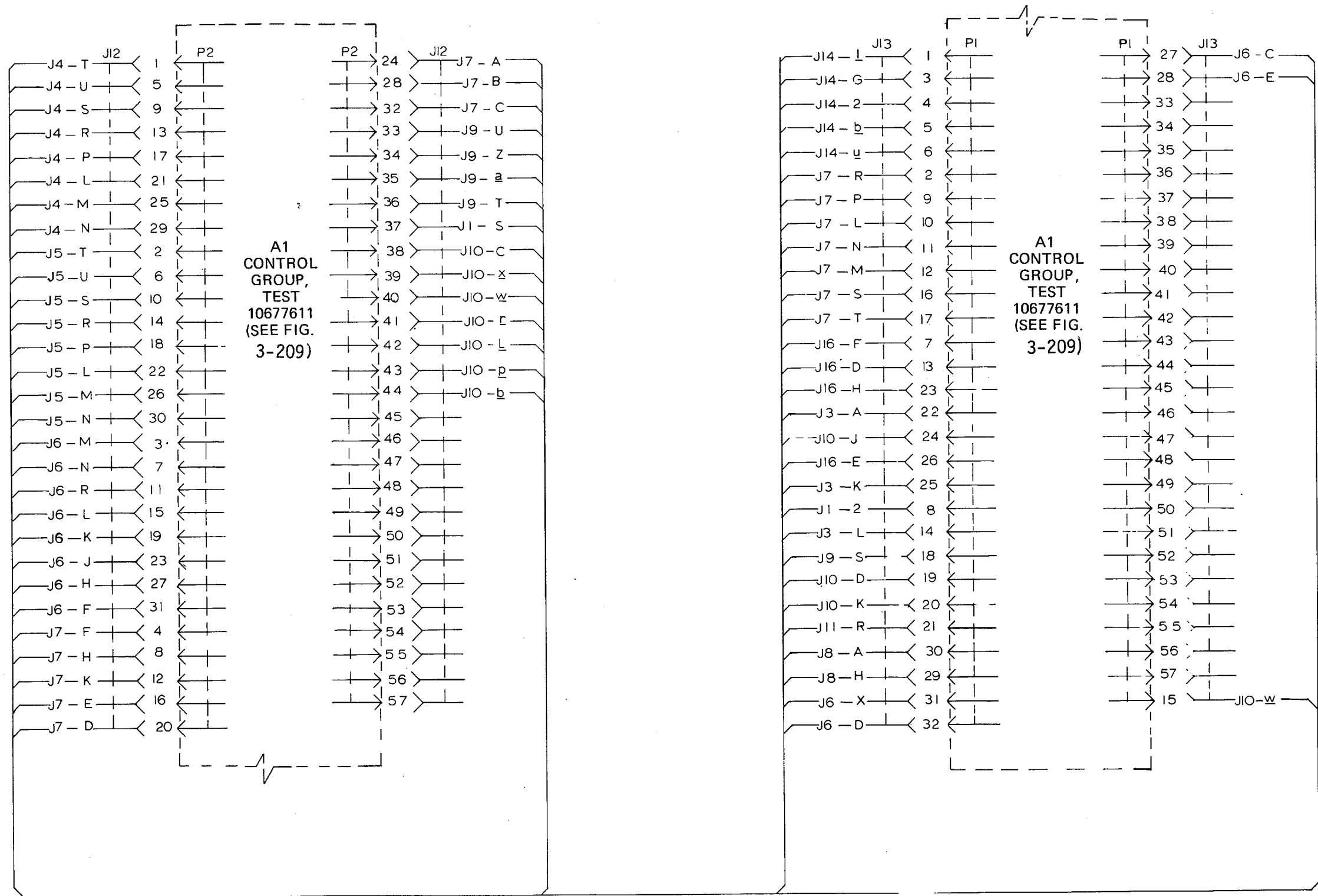
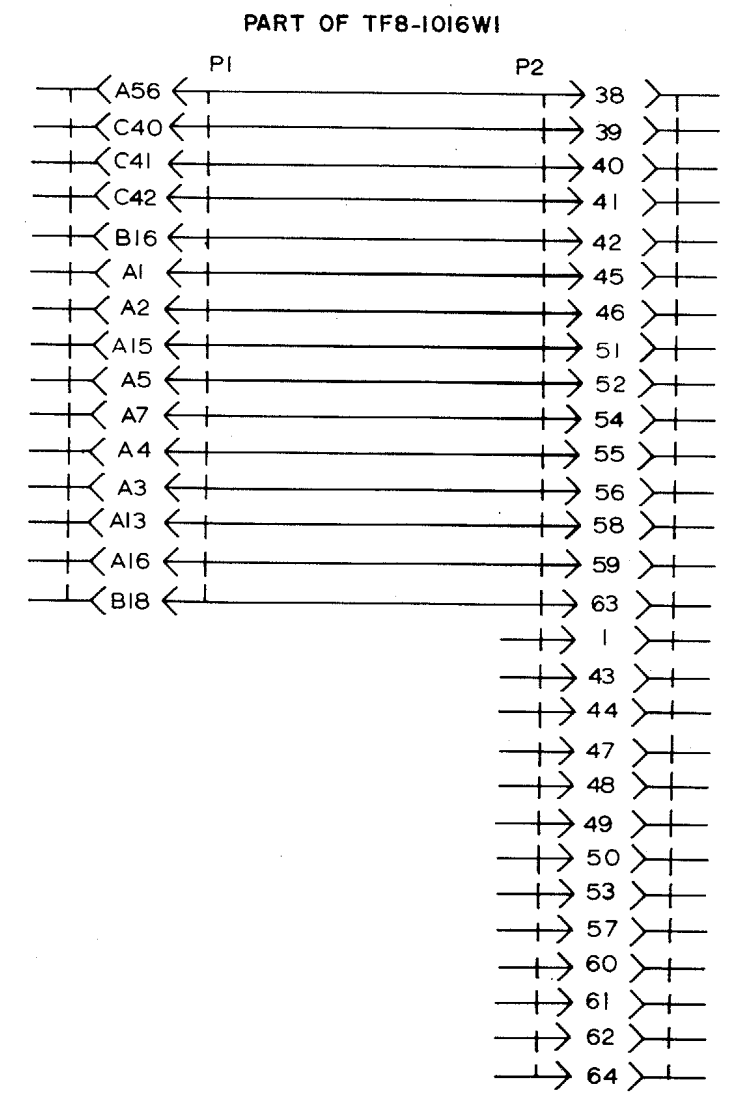
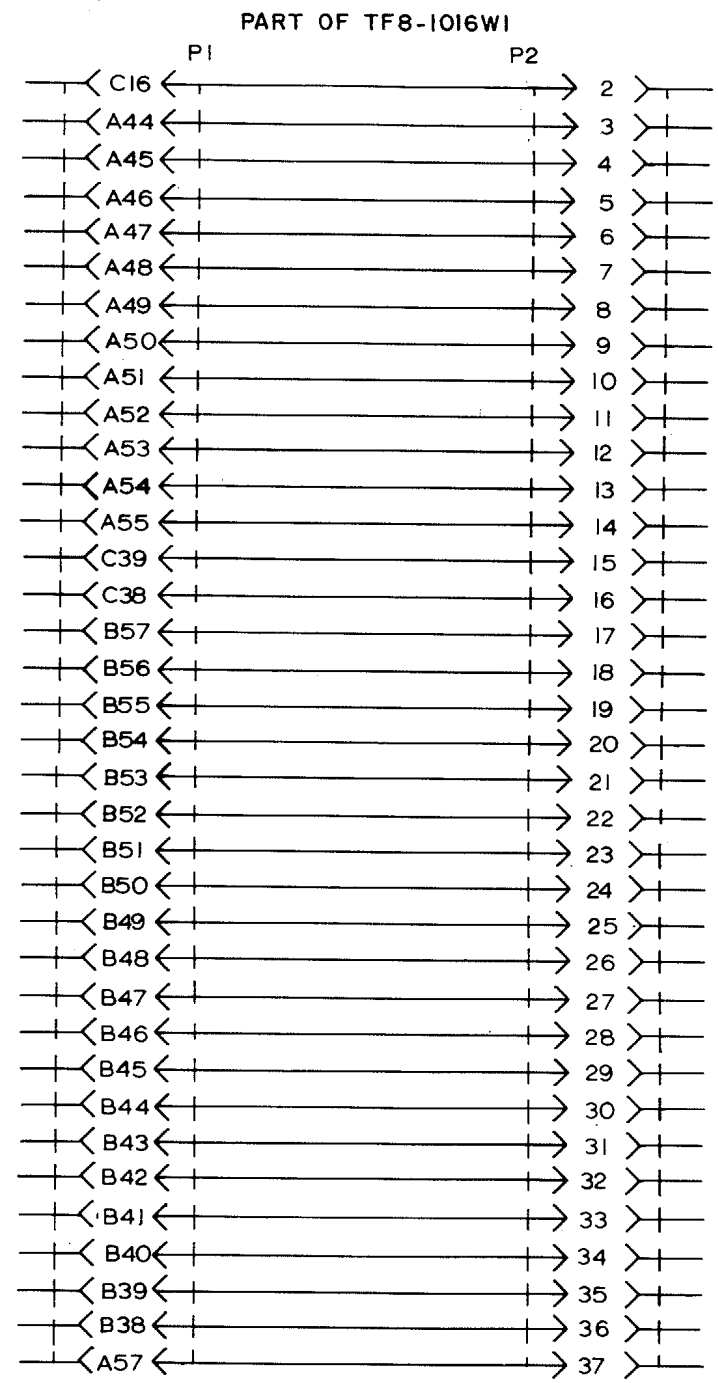
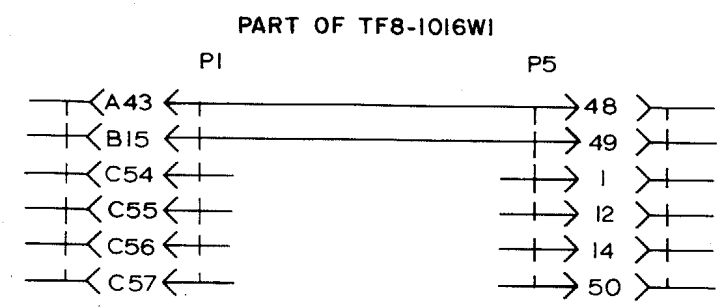
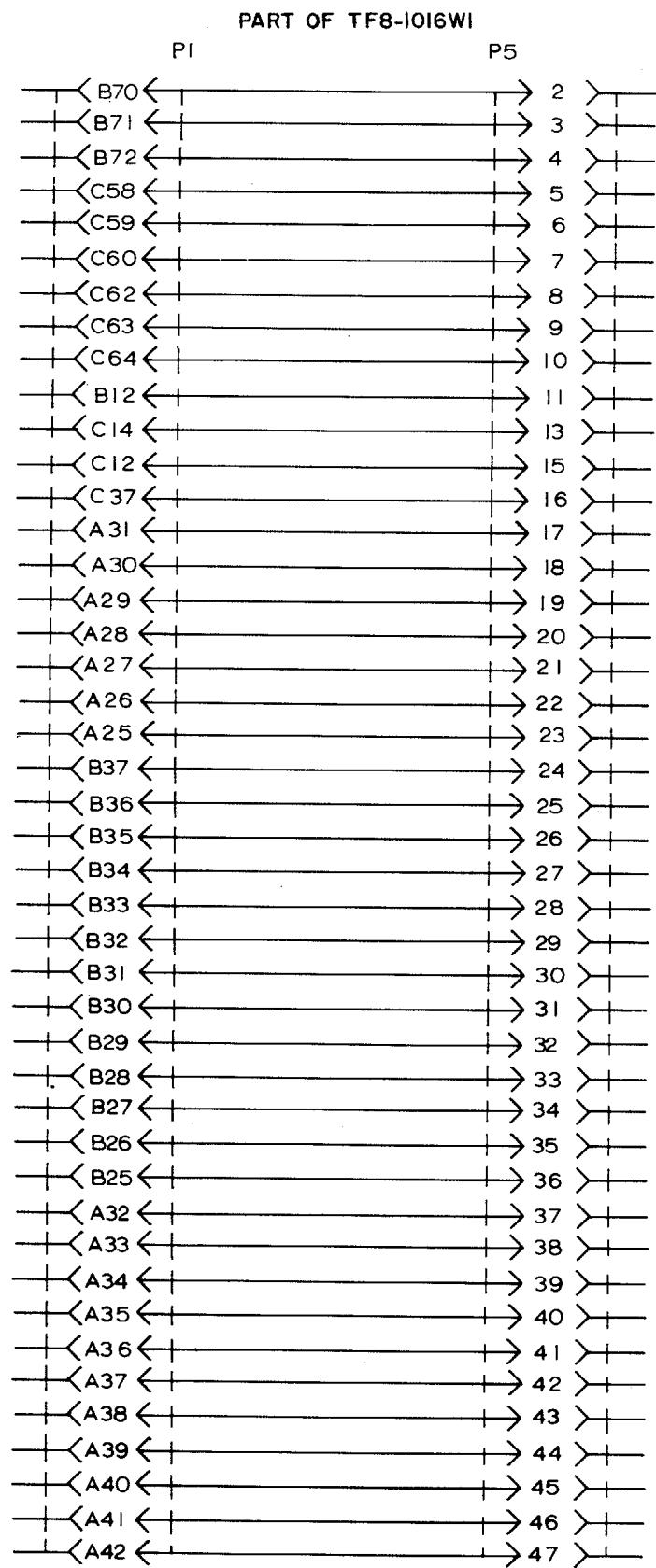

Figure 3-207. Test fixture TF8-1016 10677234 (FG 3900) schematic (Sheet 5 of 6)
3-289



MS 309290

Figure 3-207. Test fixture TF8-1016 10677234 (FG 3900) schematic (Sheet 6 of 6)
3-291



MS 309291

Figure 3-208. Test fixture TF8-1016 (test cables) schematic (Sheet 1 of 3)
3-292

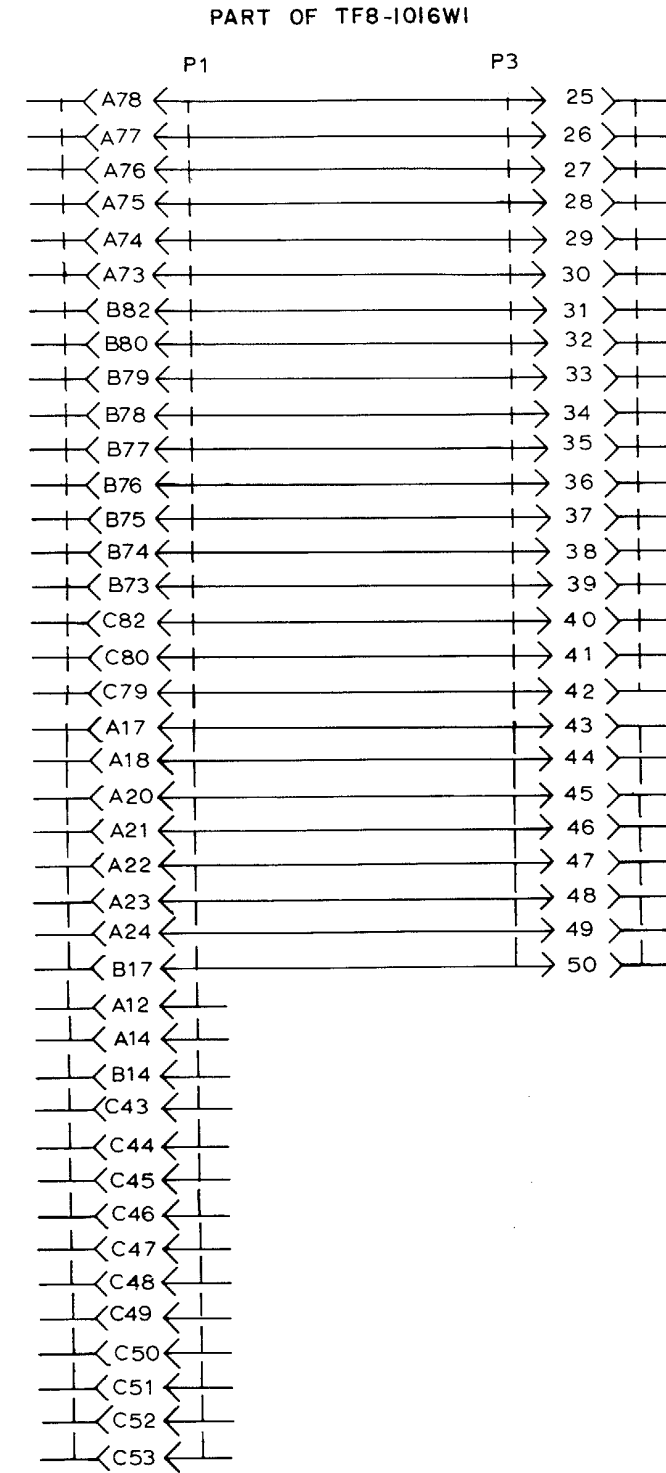
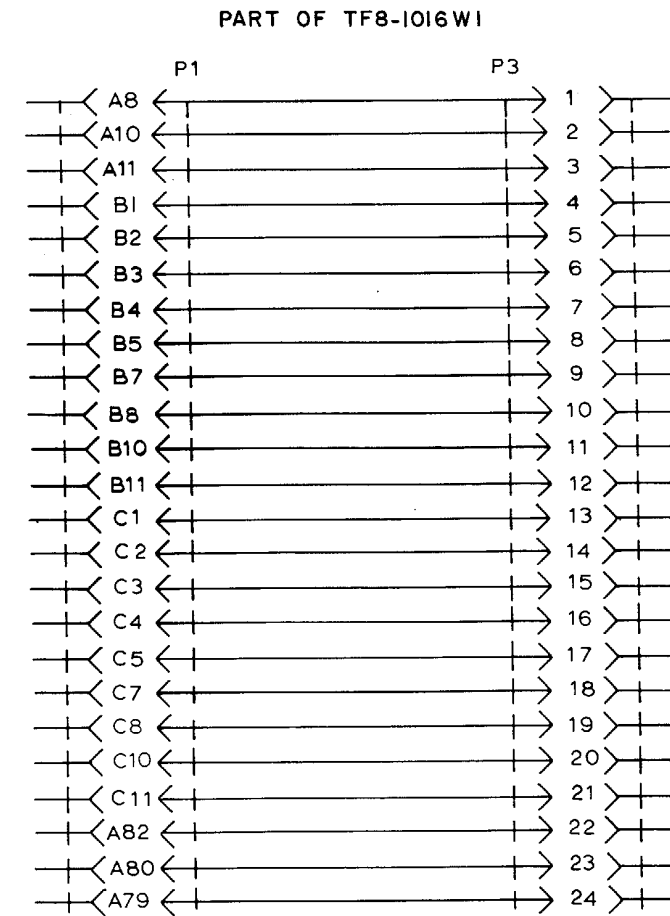
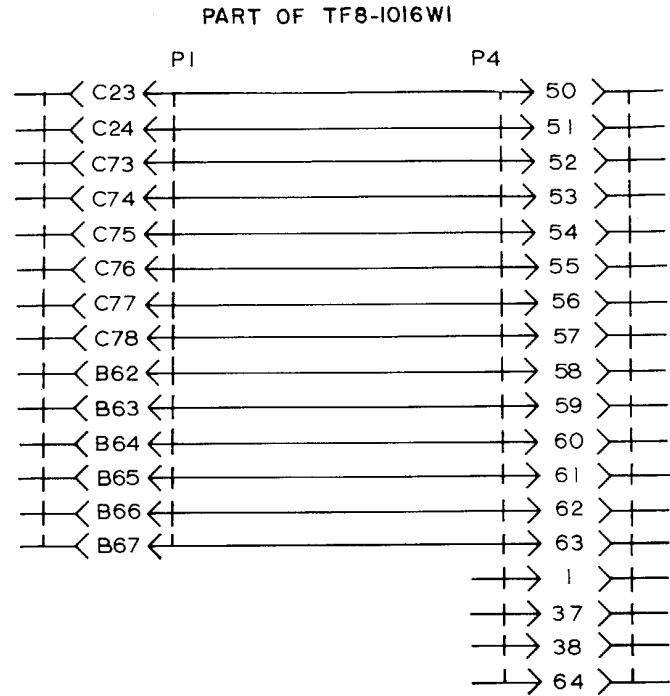
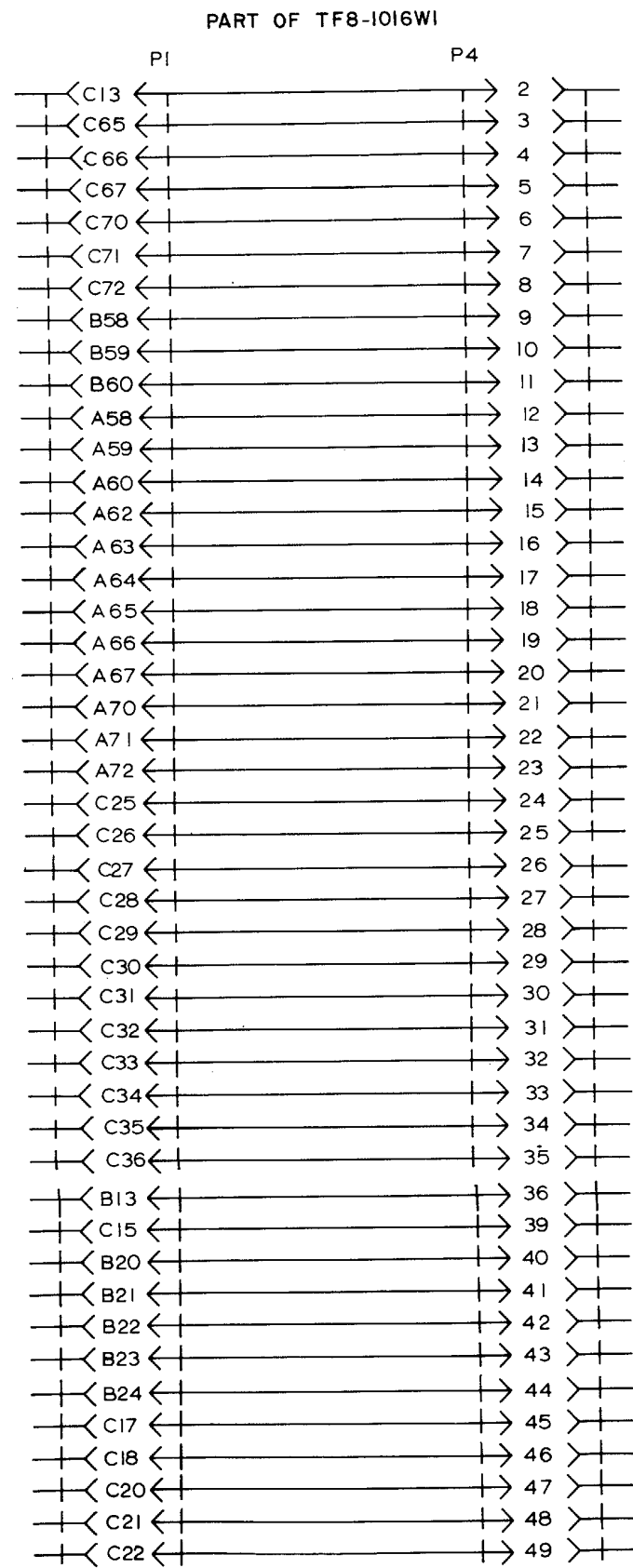

MS 309292

Figure 3-208. Test fixture TF8-1016 (test cables) schematic (Sheet 2 of 3)
3-293

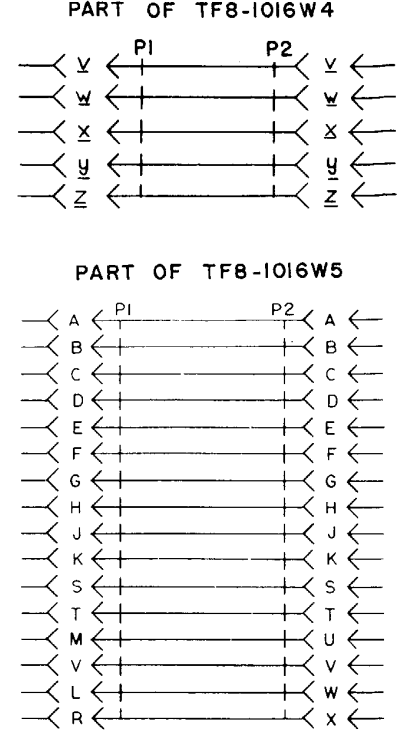
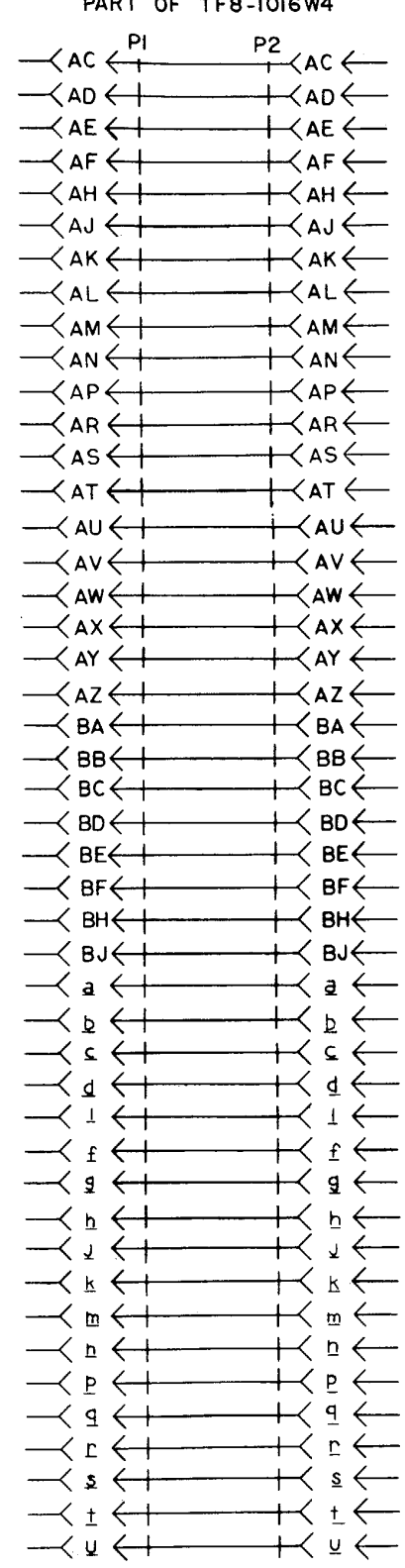
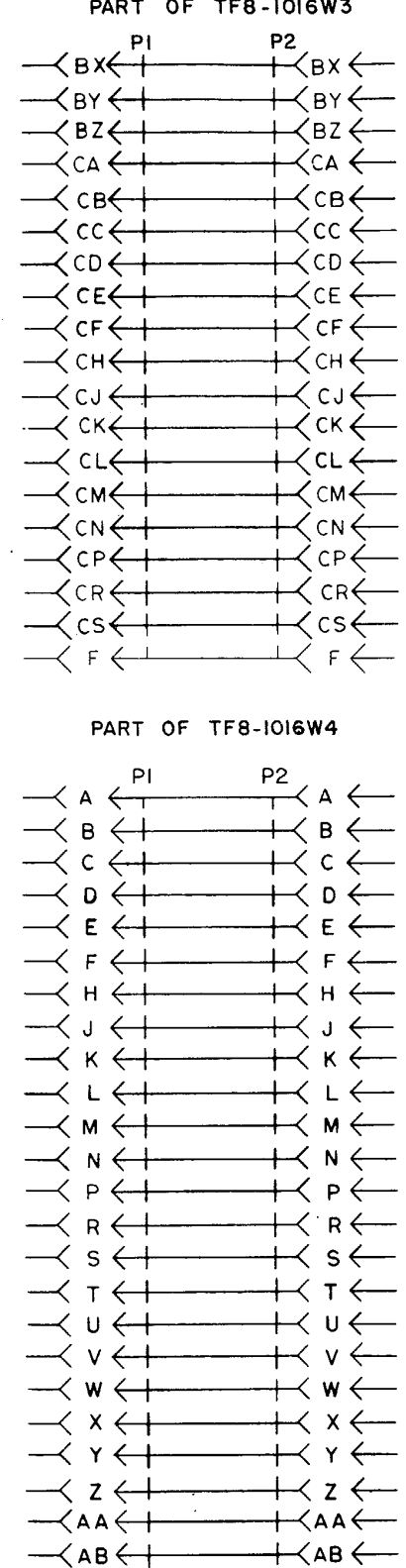
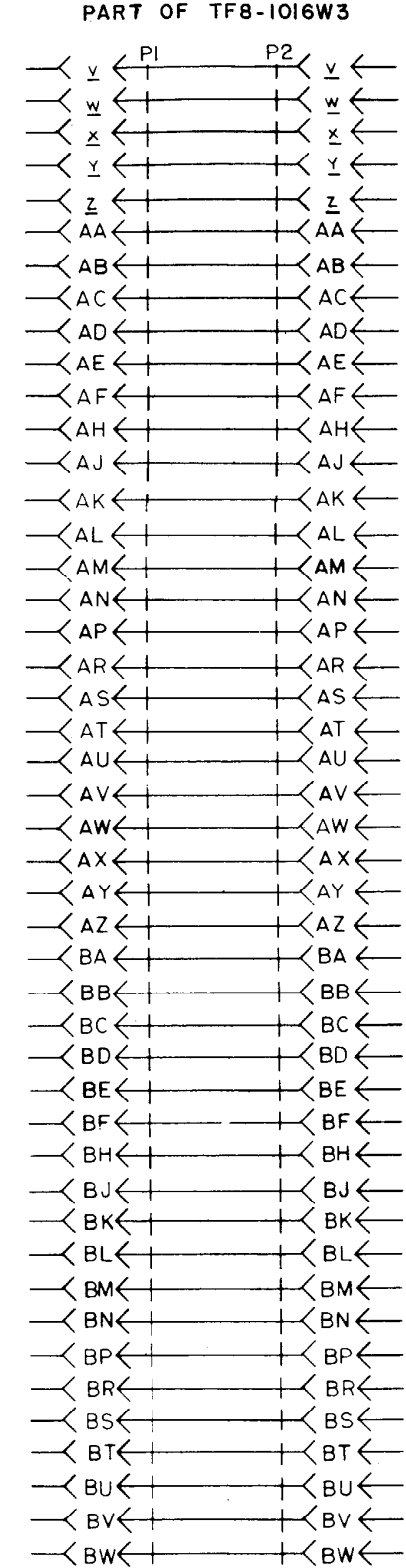
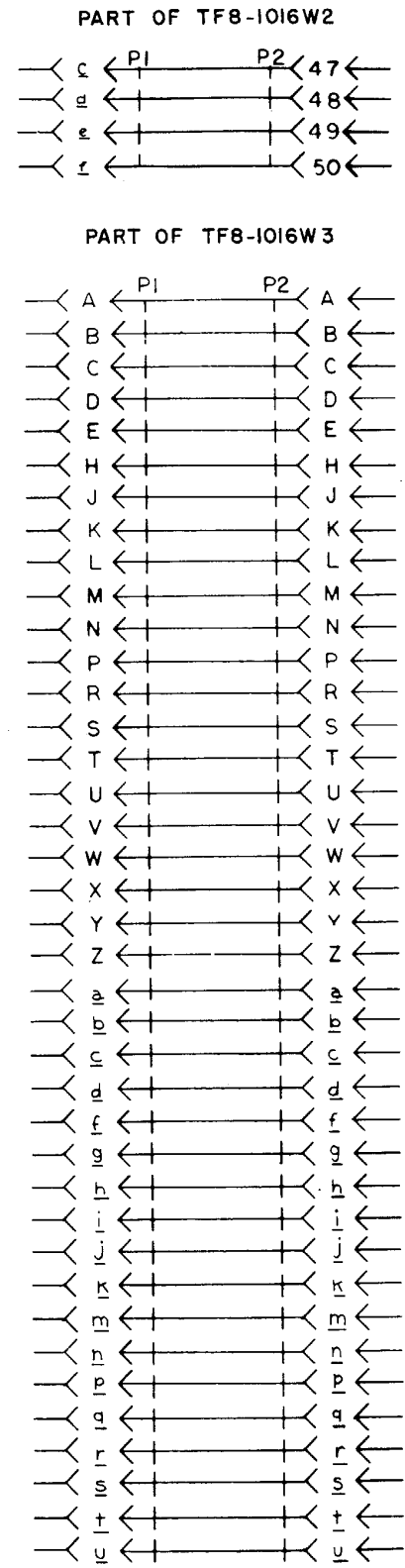
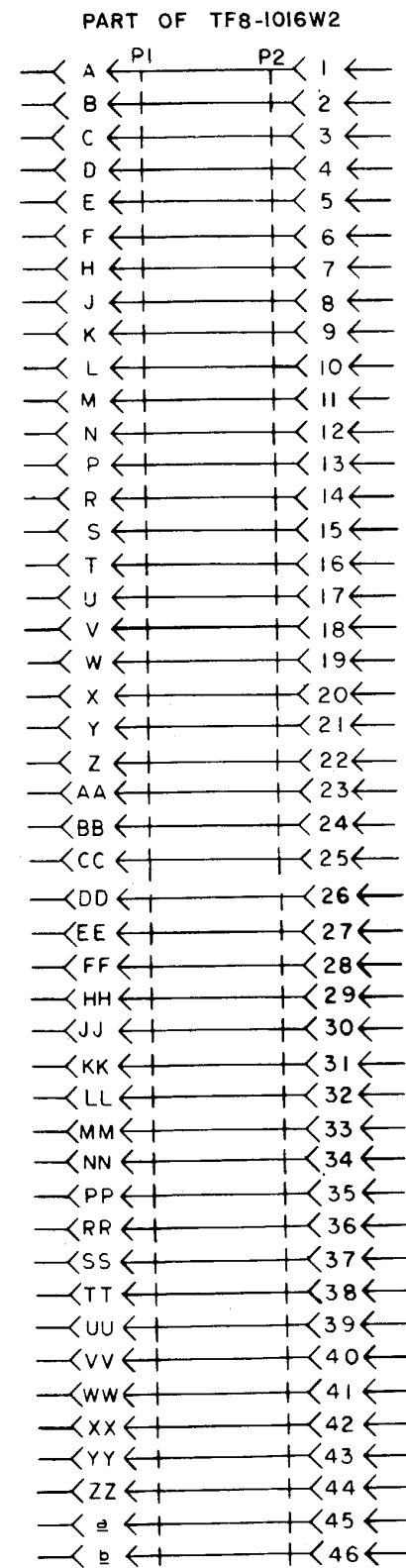
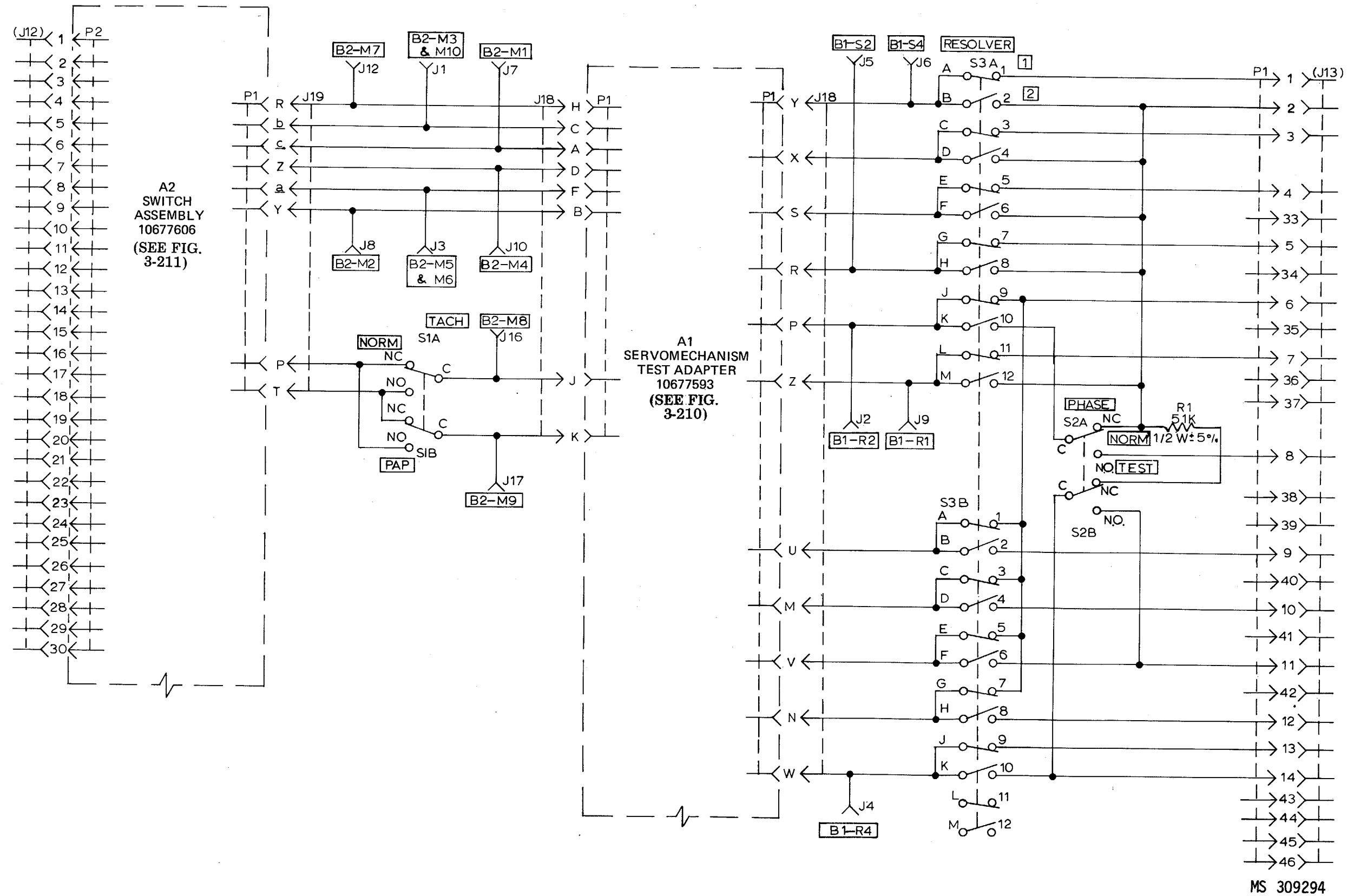

Figure 3-208. Test fixture TF8-1016 (test cables) schematic (Sheet 3 of 3)
3-295

MS 309293



MS 309294

Figure 3-209. Test control group 10677611 (A1) (FG 3970) schematic (Sheet 1 of 2)
3-296

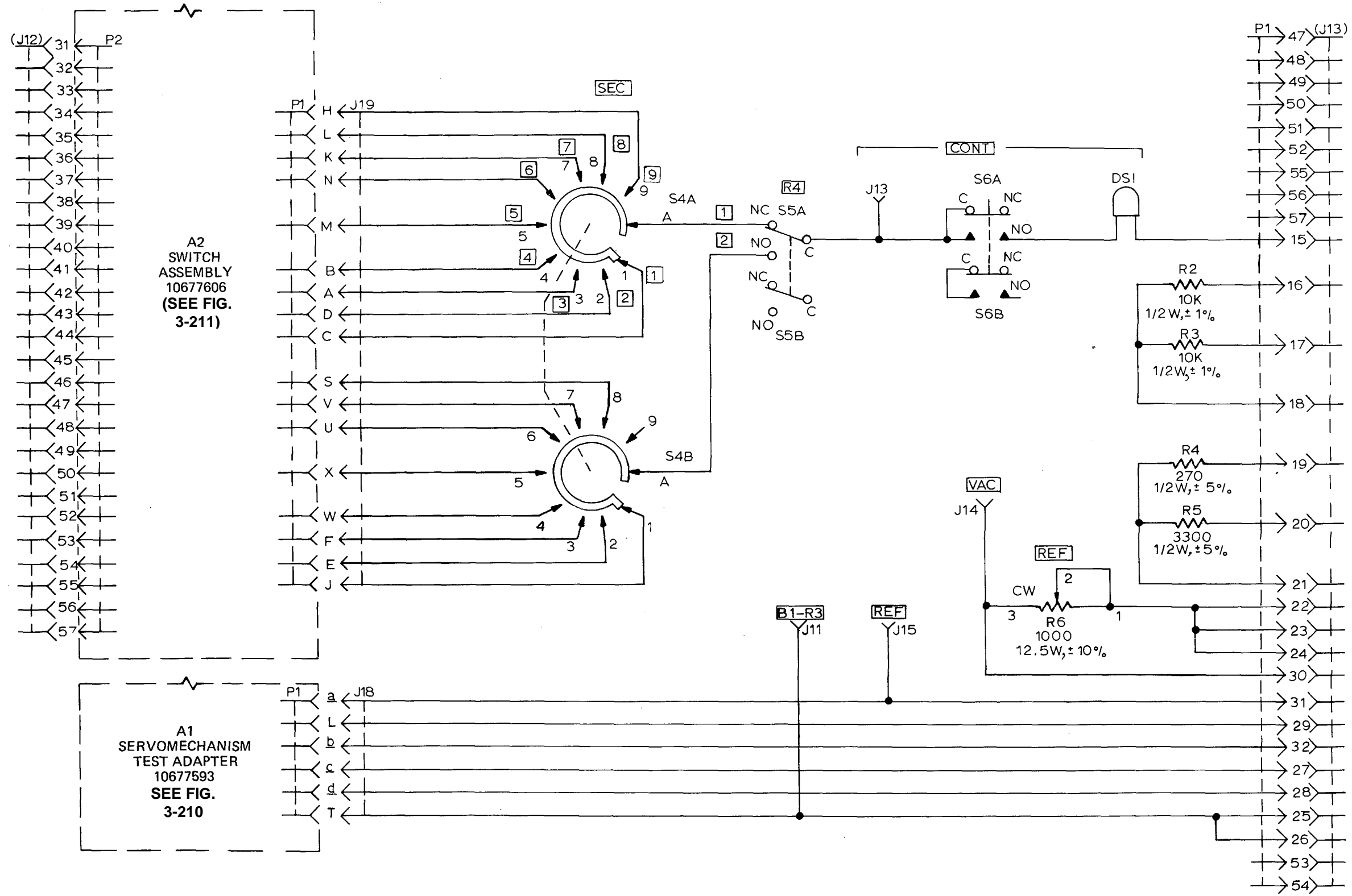

Figure 3-209. Test control group 10677611 (A1) (FG 3970)-schematic (sheet 2 of 2).

MS 309295

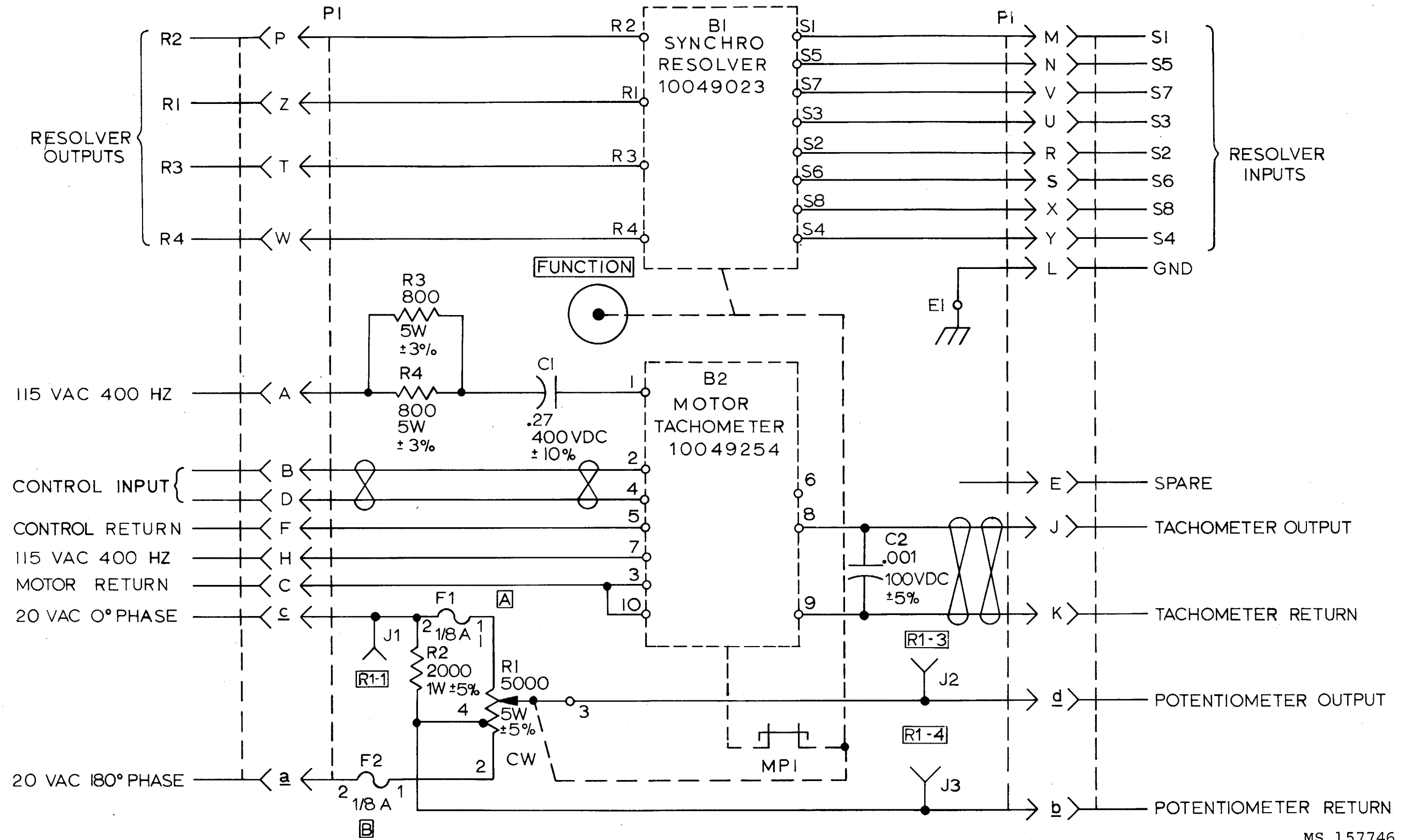
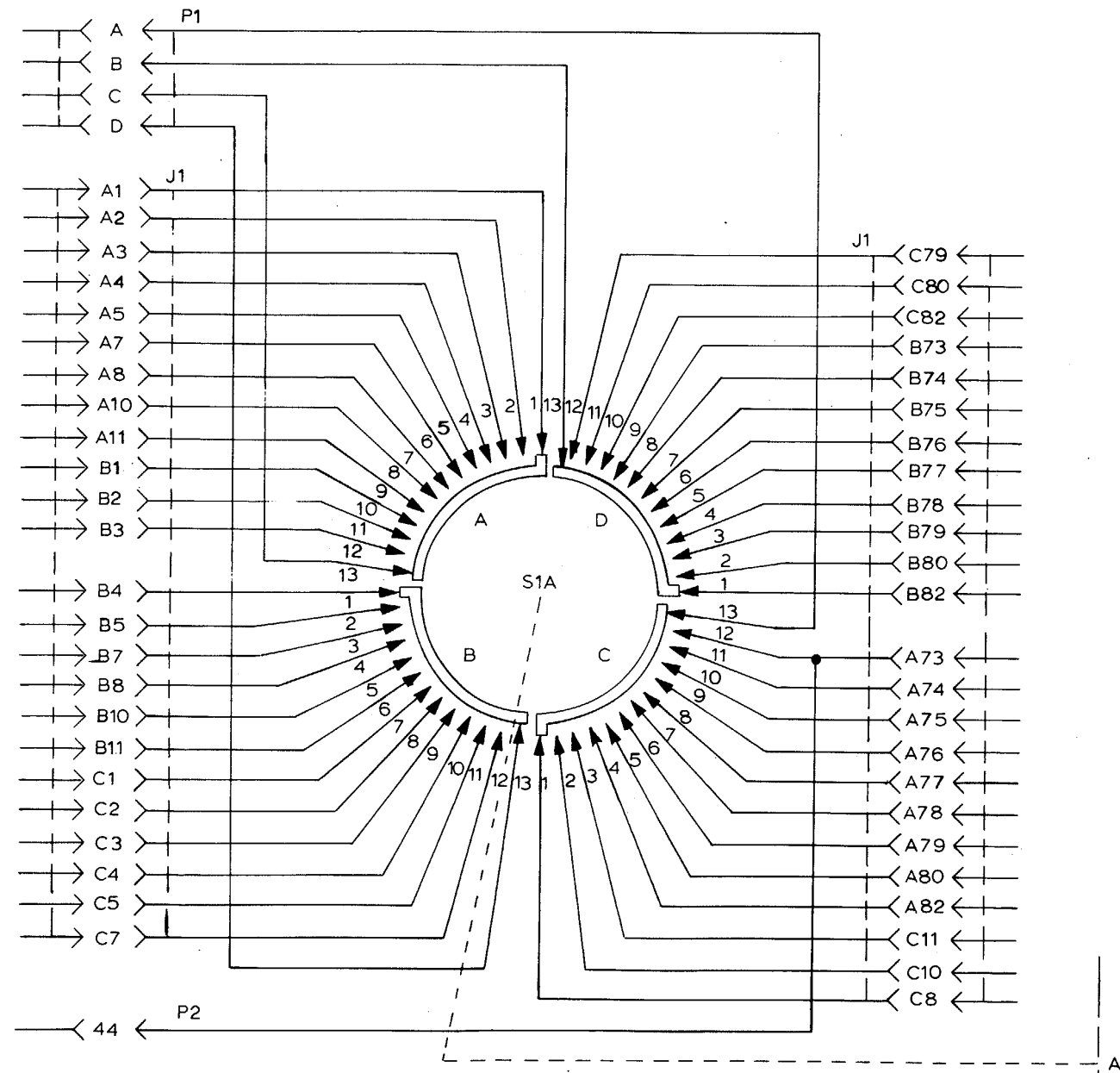
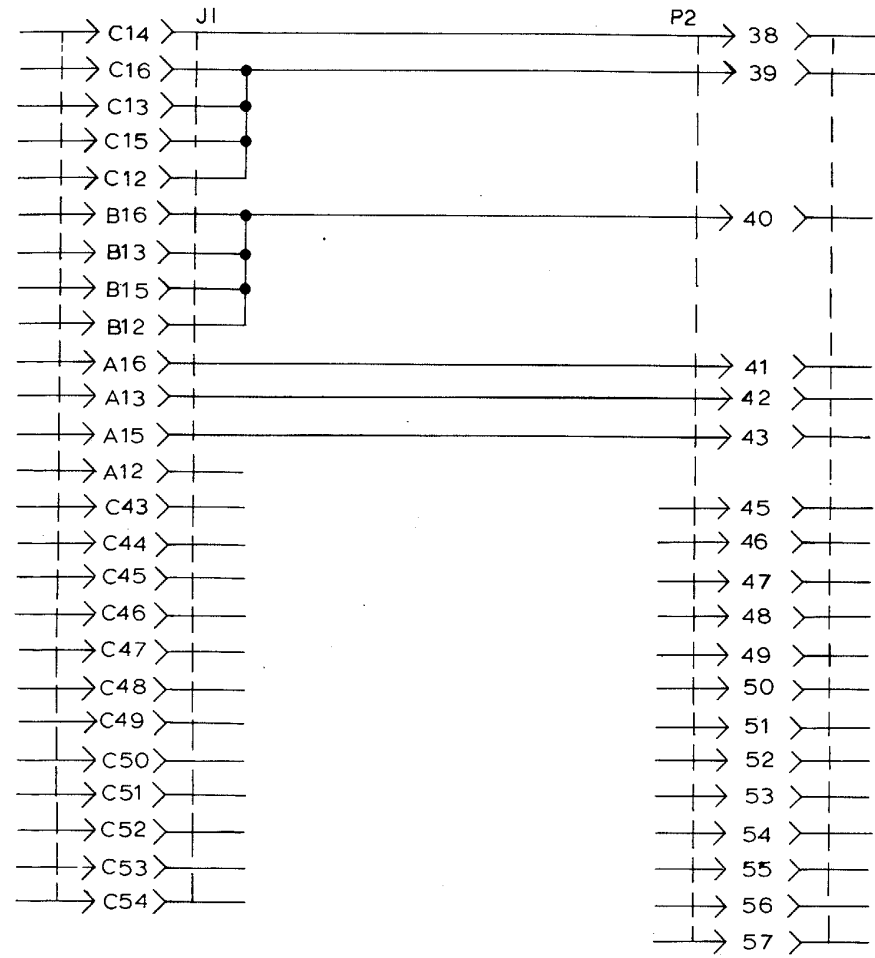

Figure 3-210. Test adapter servomechanism 10677593 (A1A1) (FG 3980)-schematic .

MS 157746



SEE SHEET 2
MS 157747

Figure 3-211. Rotary switch assembly 10677606 (A1A2) -schematic (sheet 1 of 4).

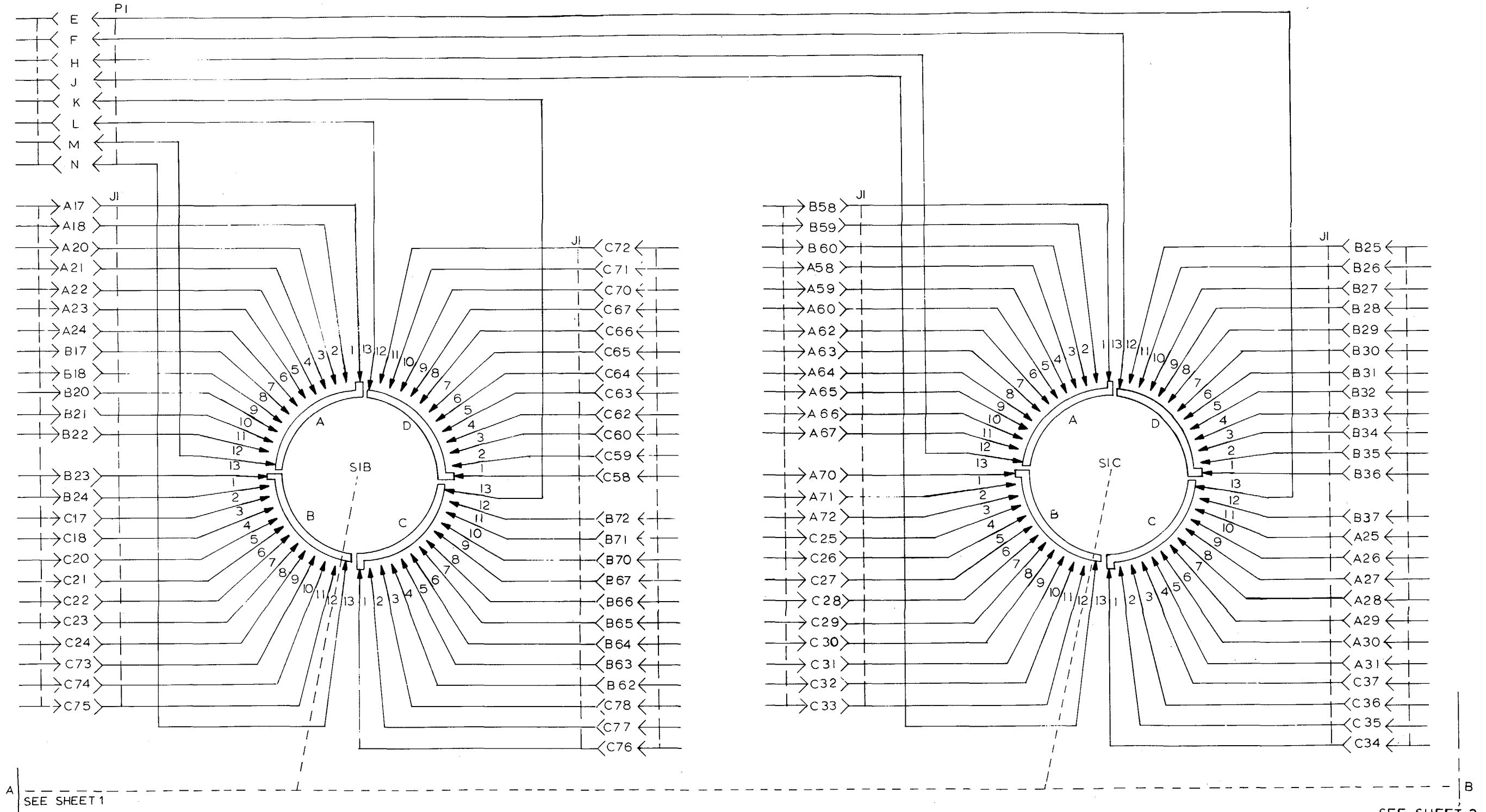
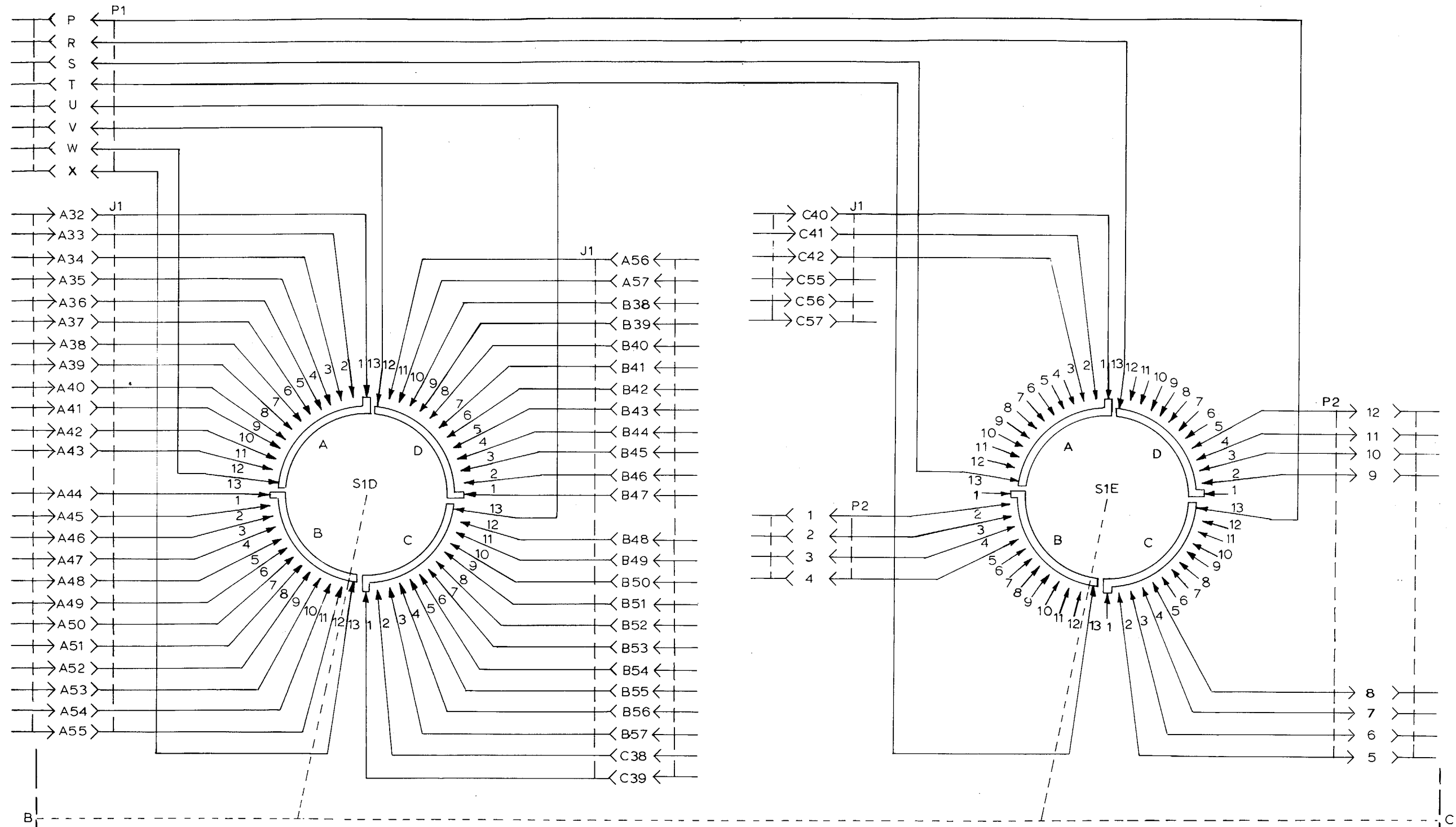

Figure 3-211. Rotary switch assembly 10677606 (A1A2) -schematic (sheet 2 of 4).



SEE SHEET 2

SEE SHEET 4
MS 157749

Figure 3-211. Rotary switch assembly 10677606 (A1A2) -schematic (sheet 3 of 4).

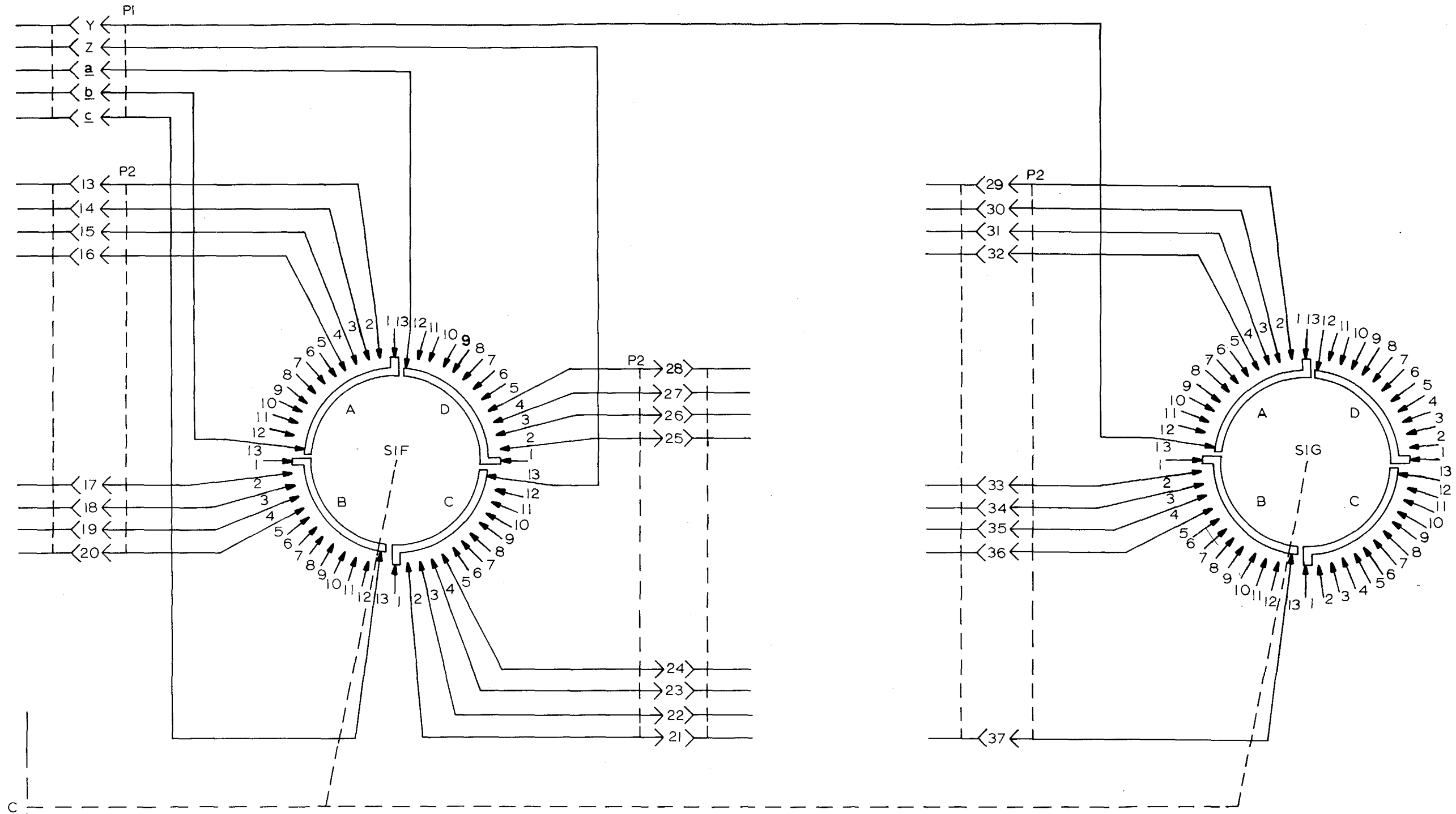

SEE SHEET 3

Figure 3-211. Rotary switch assembly 10677606 (A1A2) -schematic (sheet 4 of 4).

MS 157750

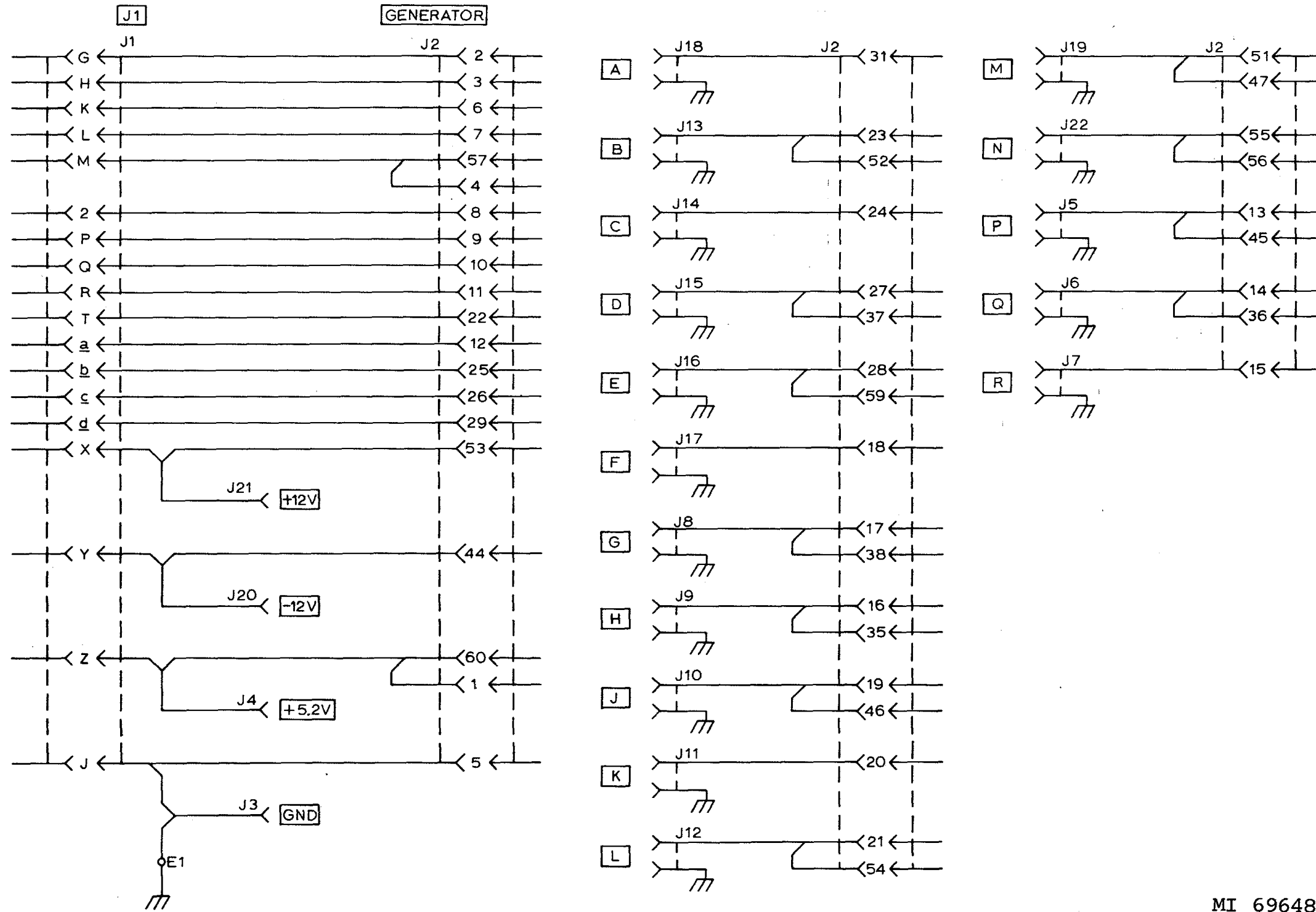
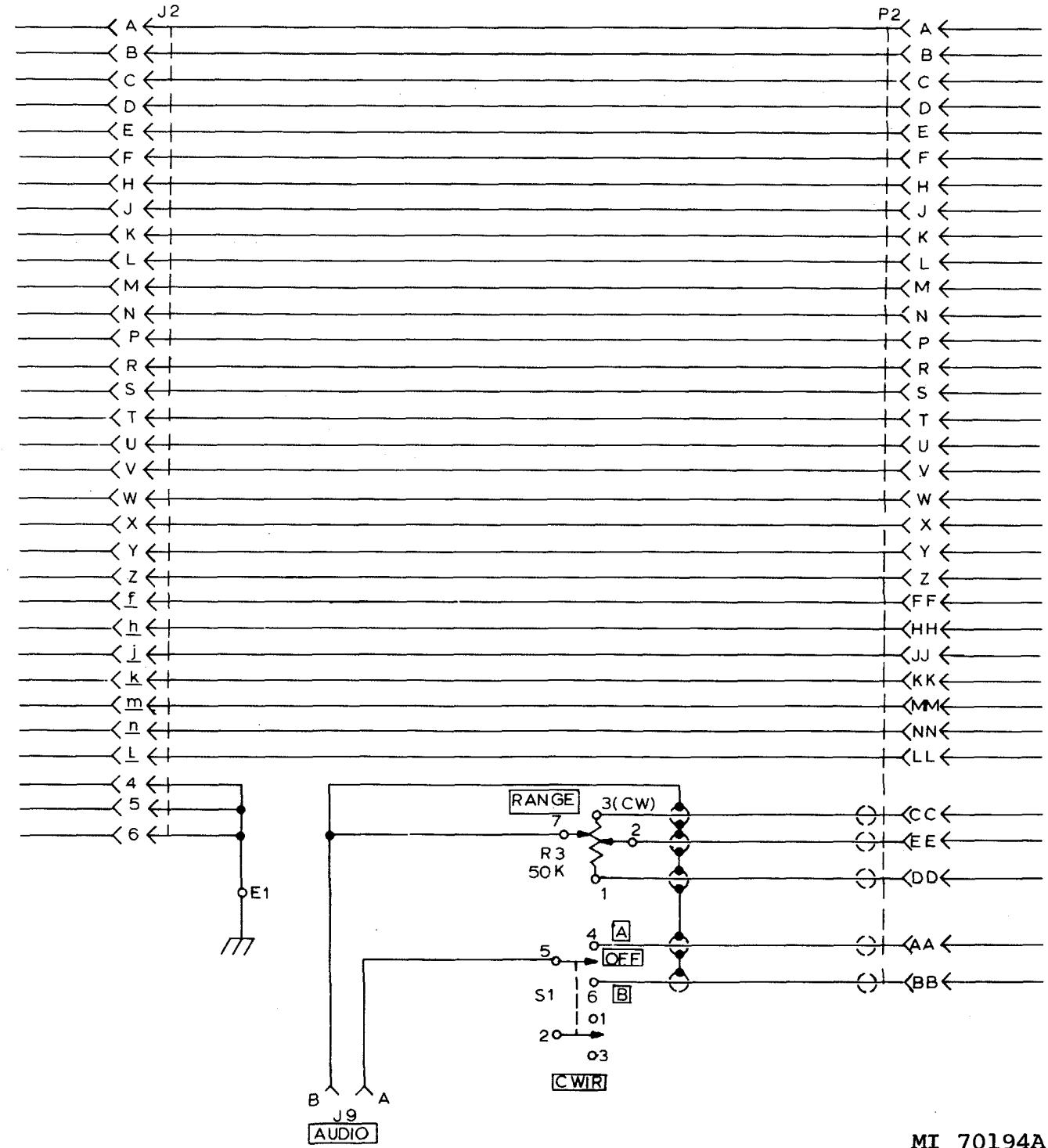
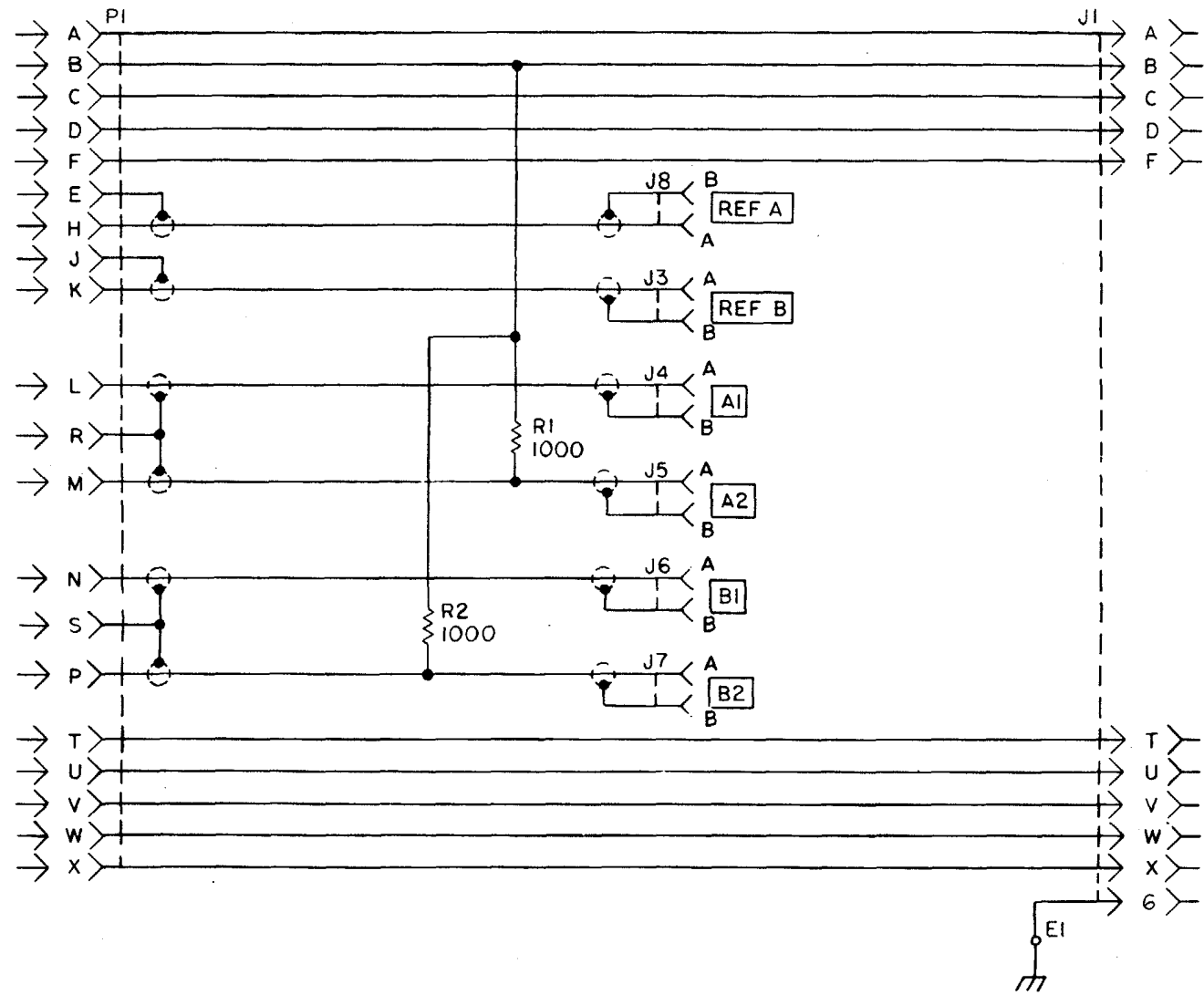

Figure 3-212. Text fixture TF8-1017 10288325 (FG 4200)-schematic.

MI 69648



MI 70194A

Figure 3-214. Unit adapter UA8-104 10674586 (FG 3000)-schematic.

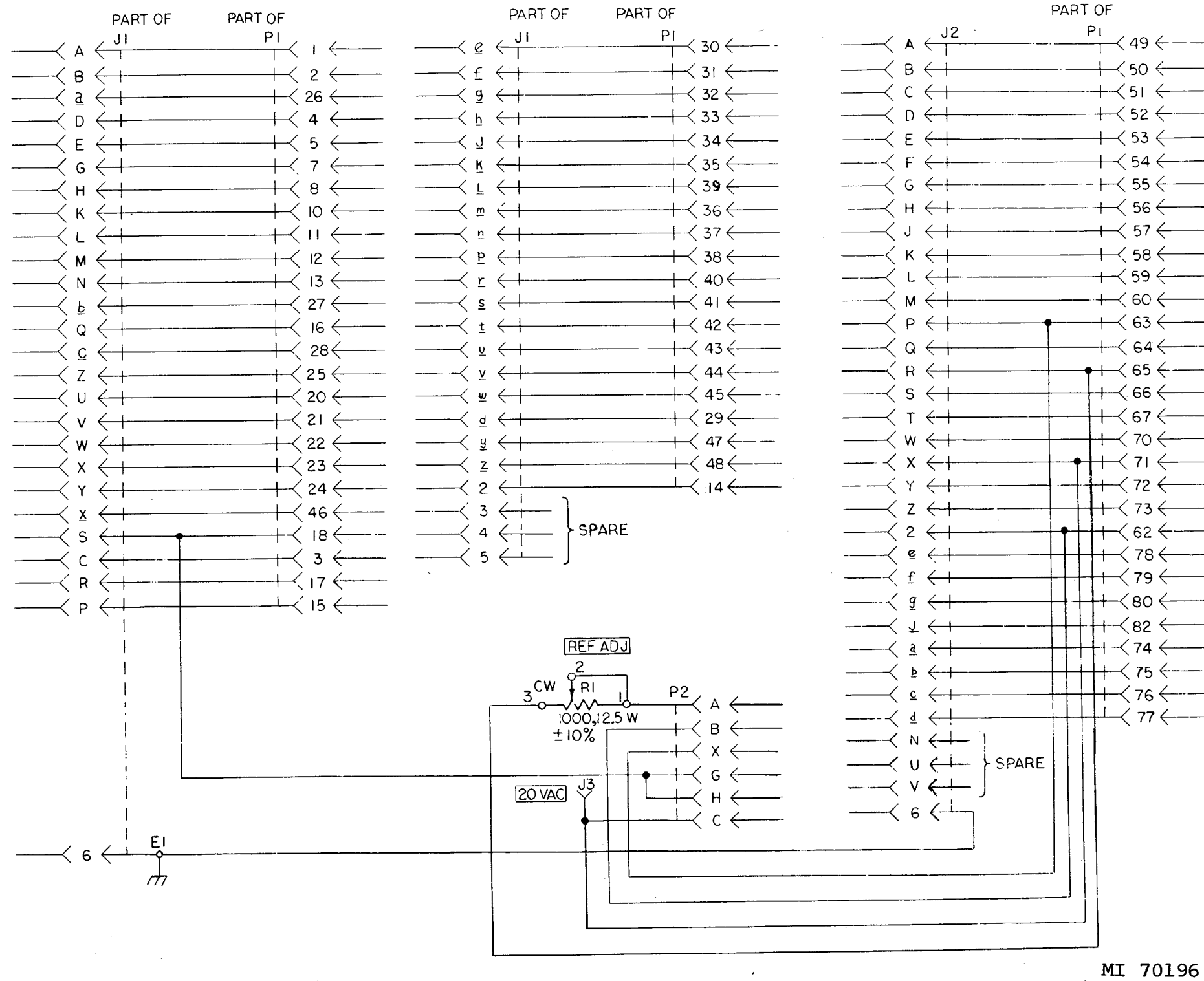

MI 70196

Figure 3-215. Unit adapter UA8-105 10671779 (FG 3020)-schematic

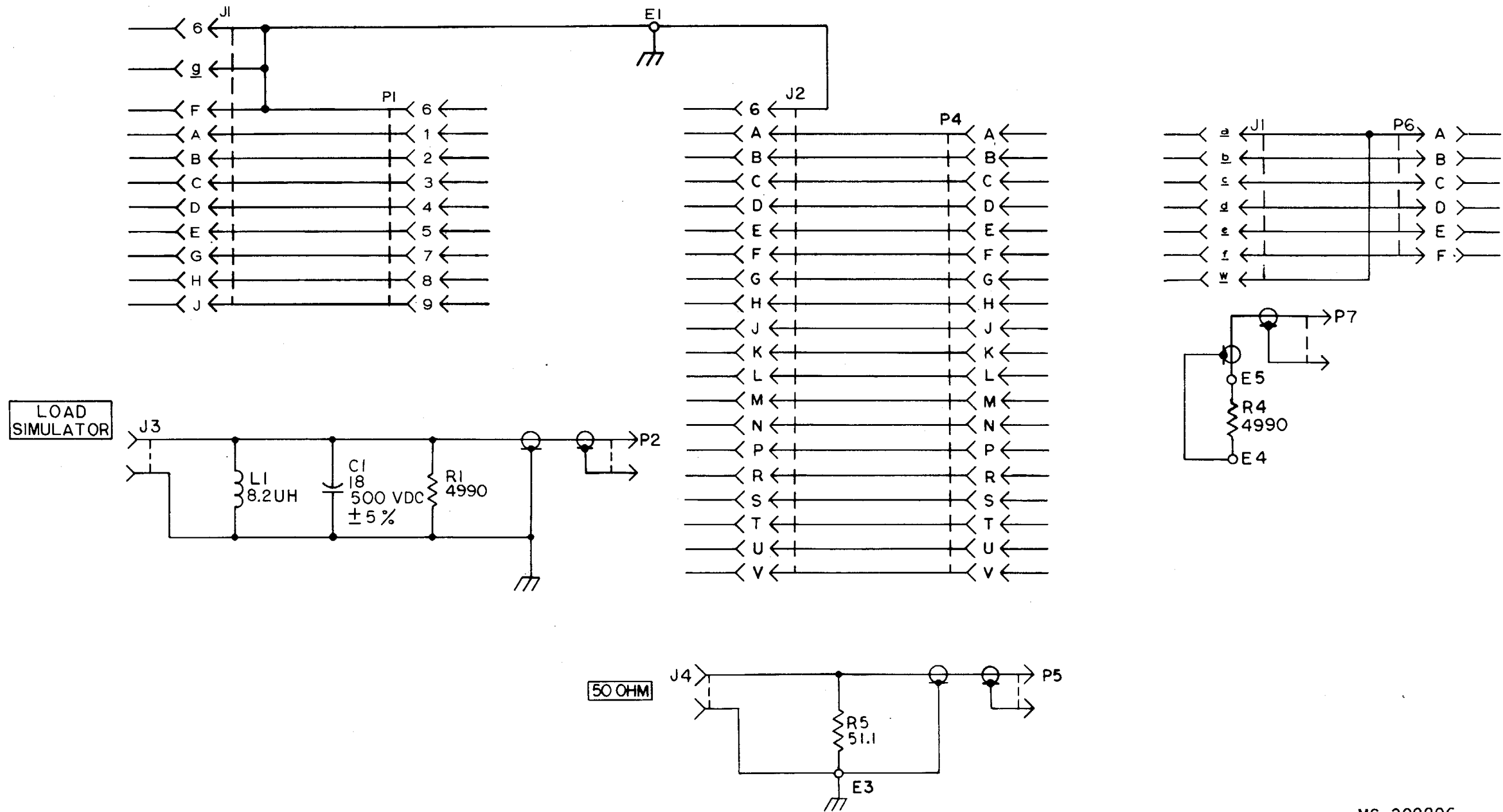
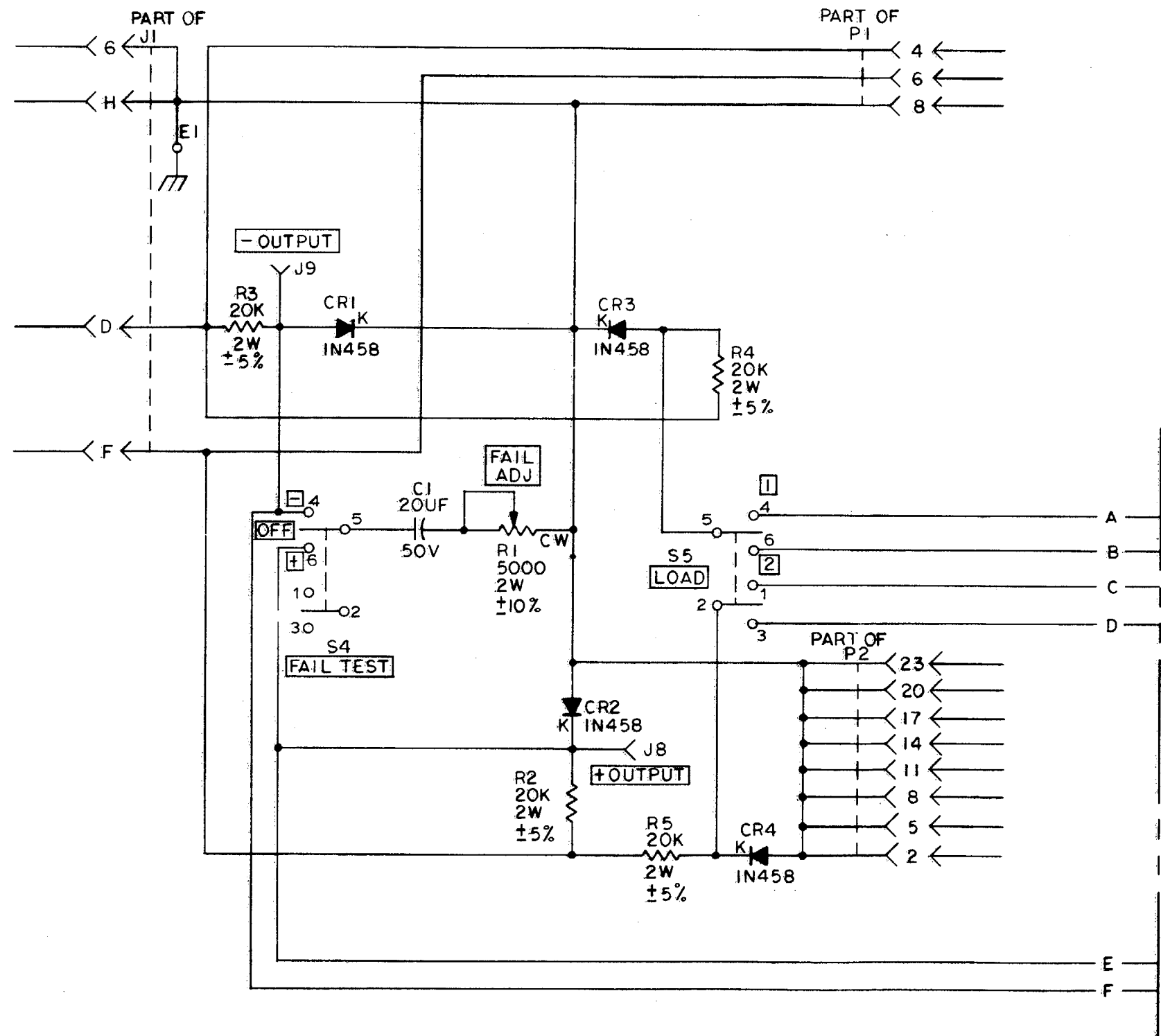
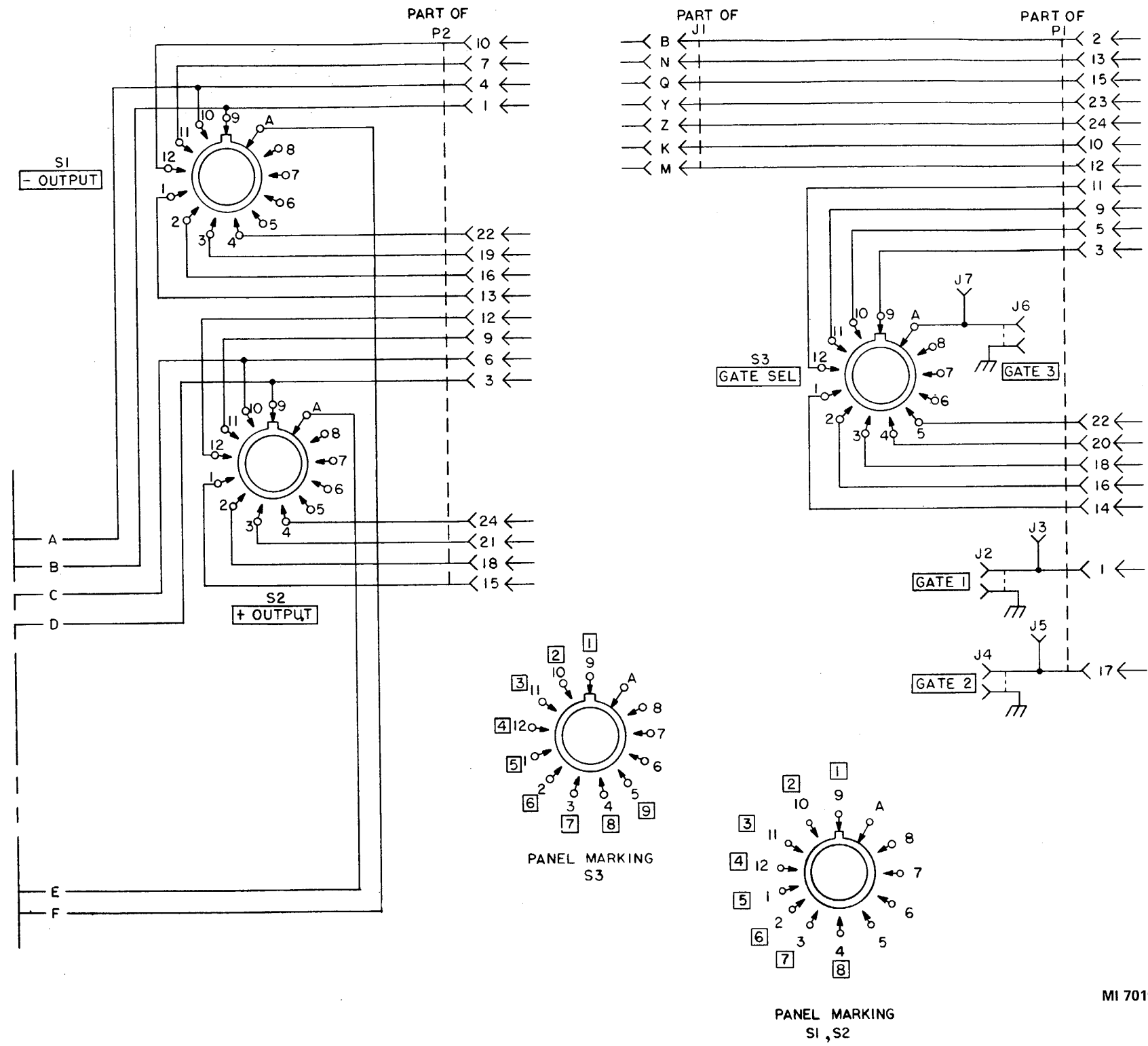

Figure 3-216. Unit adapter UA8-1022B 10291956 (FG 3040)-schematic .



SEE SHEET 2
MI 70198A

Figure 3-217. Unit adapter UA8-1034 10670671 (FG 3060)-schematic (sheet 1 of 2).



MI 70199

Figure 3-217. Unit adapter UA8-1034 10670671 (FG 3060)-schematic (sheet 2 of 2).

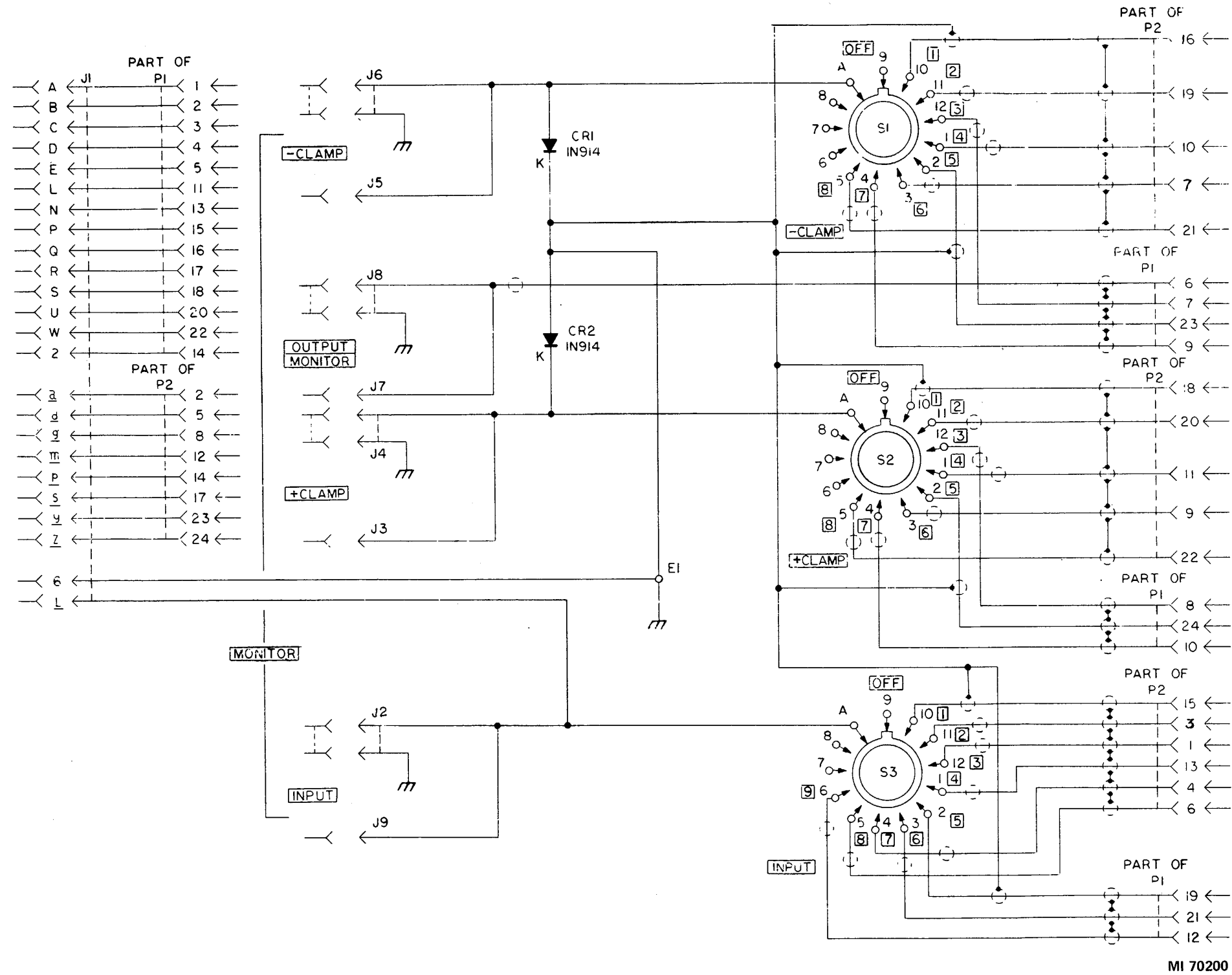

MI 70200

Figure 3-218. Unit adapter UA8-1035 10670897 (FG 3080)-schematic

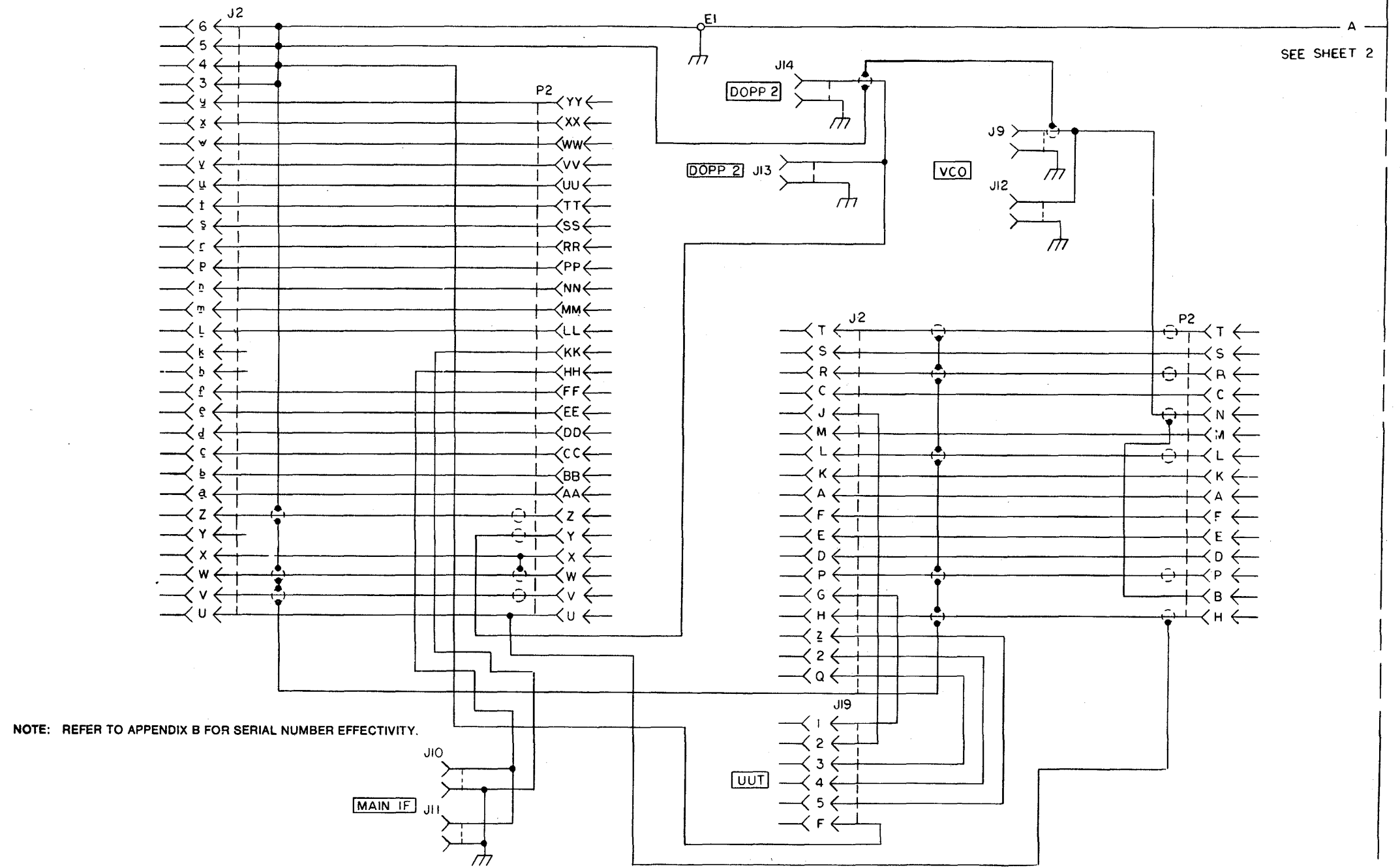

Figure 3-219. Unit adapter UA8-1036 10671781 *(AB) (see note) (FG 3100)- schematic (sheet 1 of 2).

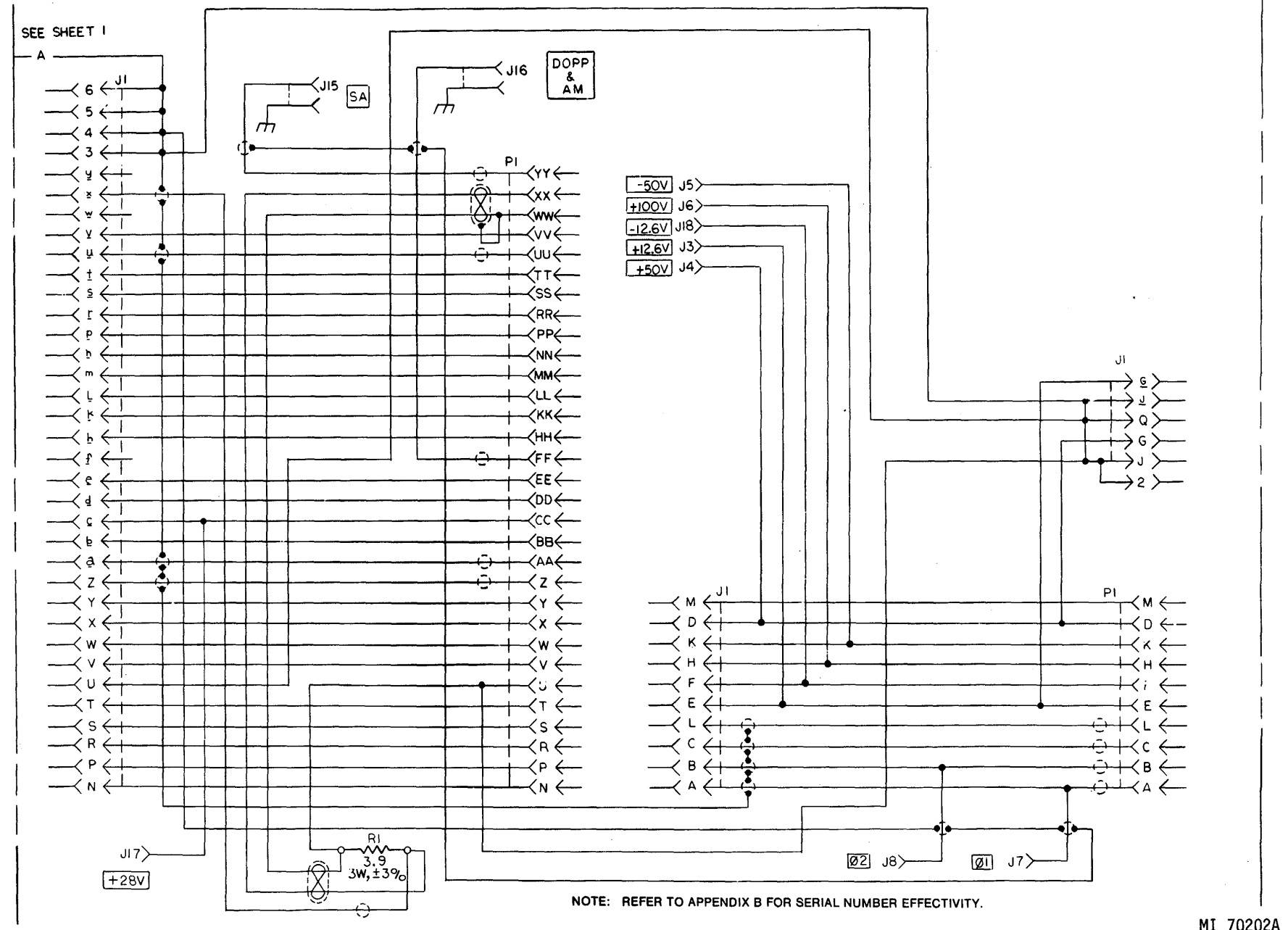

Figure 3-219. Unit adapter UA8-1036 10671781 *(AB) (see note) (FG 3100)- schematic (sheet 2 of 2).

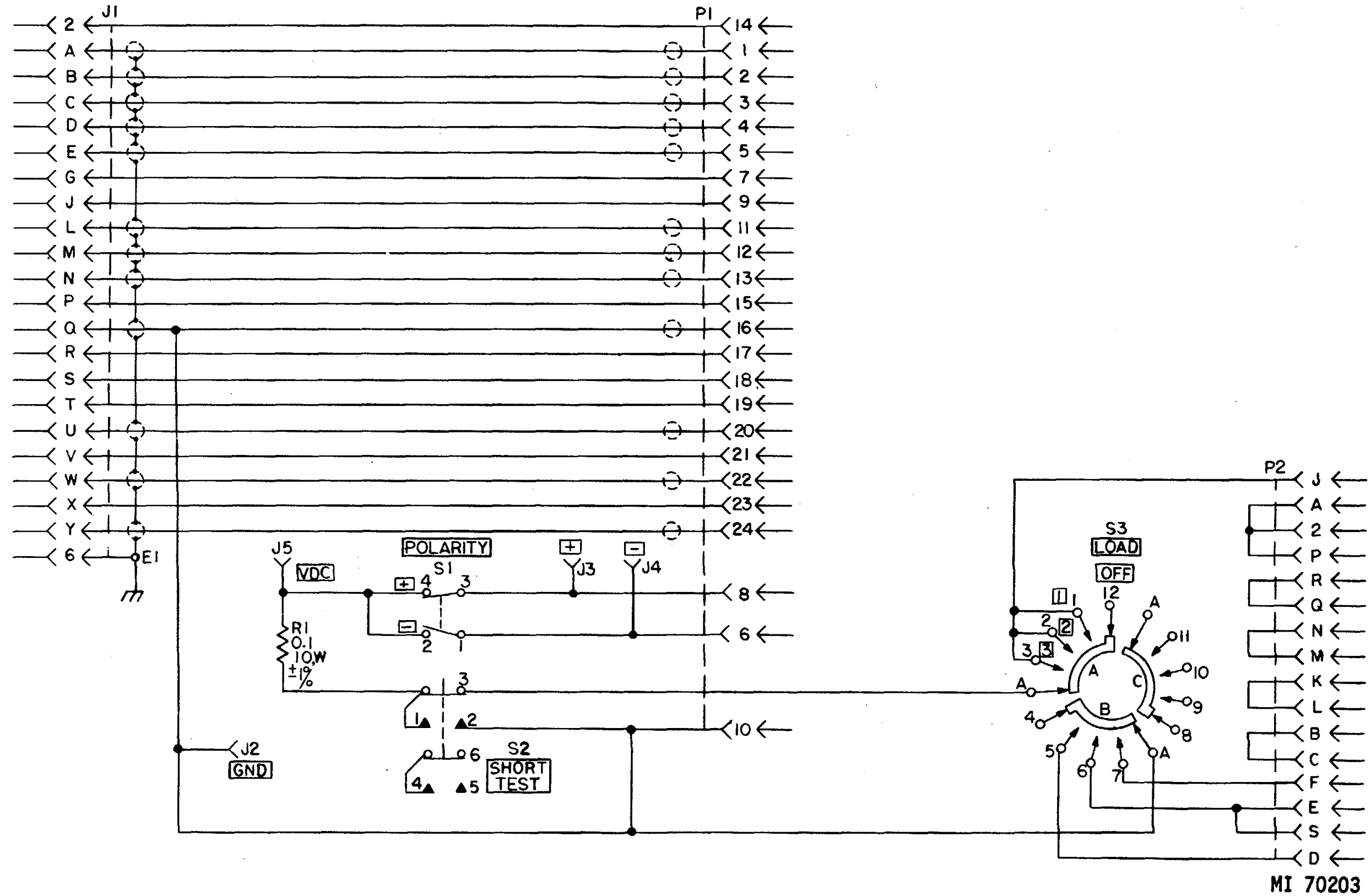

Figure 3-220. Unit adapter UA8-1037 10670893 (FG 3120)- schematic.

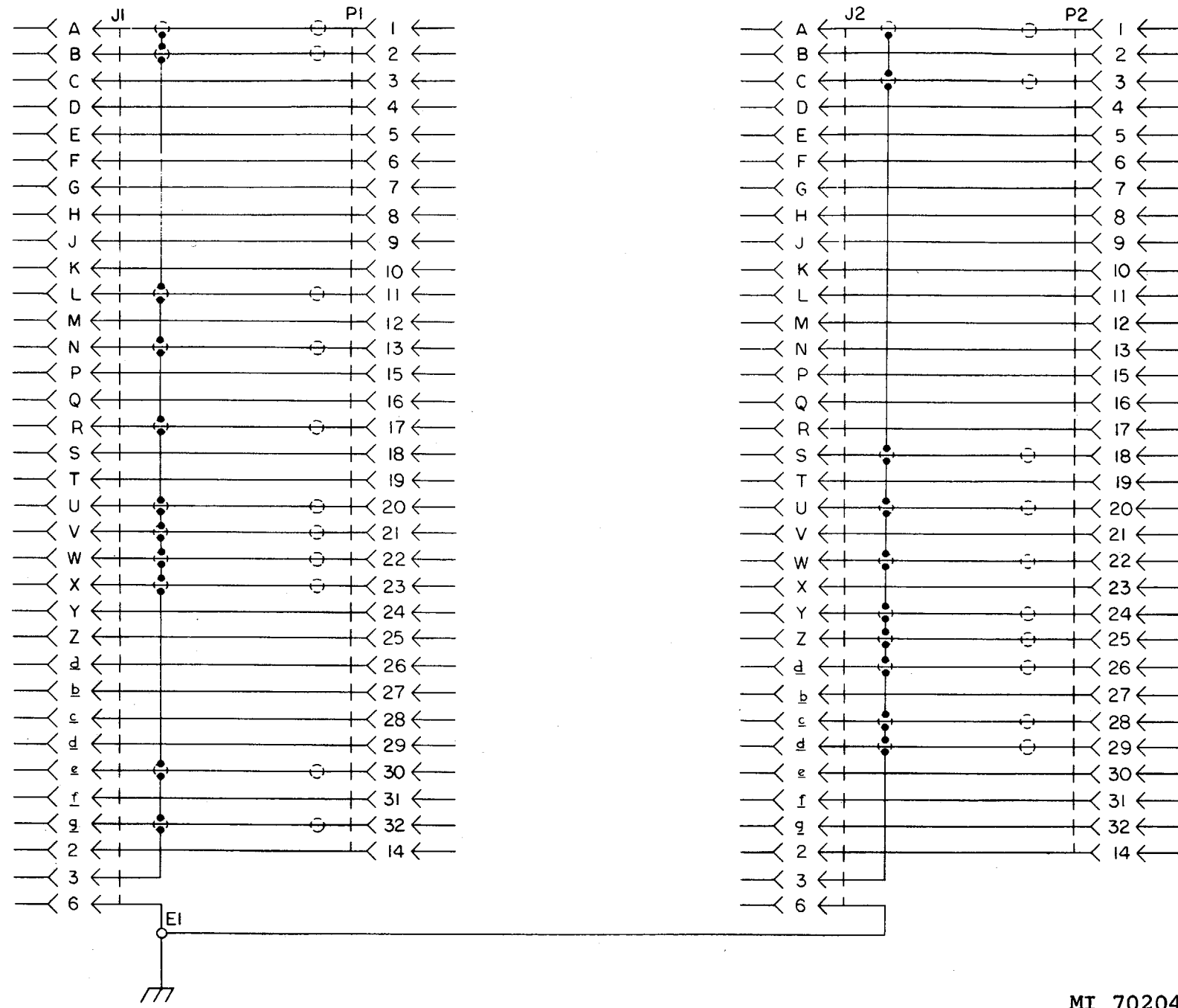
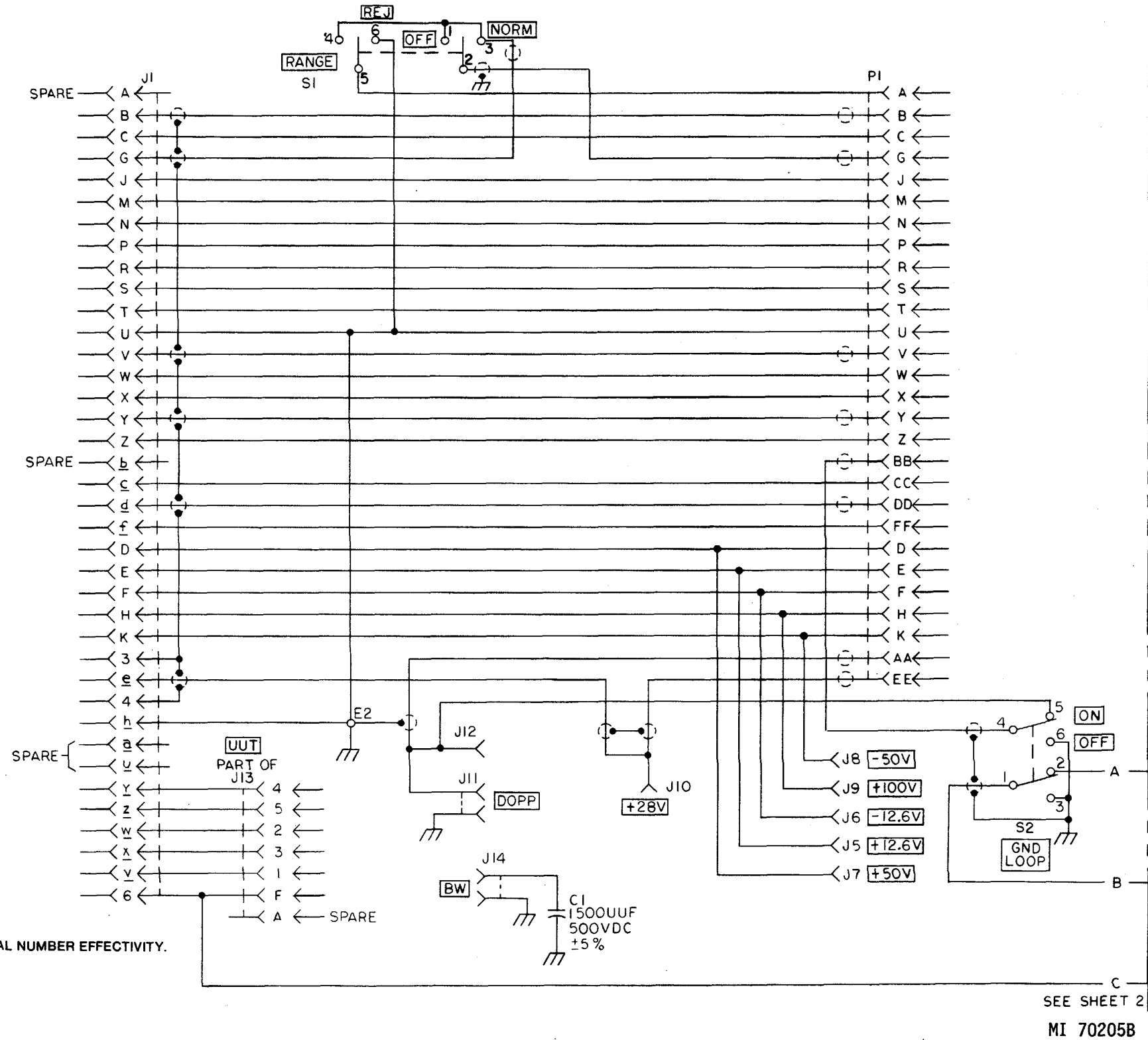

Figure 3-221. Unit adapter UA8-1038 10671280* (FG 3140)- schematic.

MI 70204



NOTE: REFER TO APPENDIX B FOR SERIAL NUMBER EFFECTIVITY.

Figure 3-222 Unit adapter UA8-1040 10671782* (AB) (see note)(FG 3160)- schematic (sheet 1 of 2)

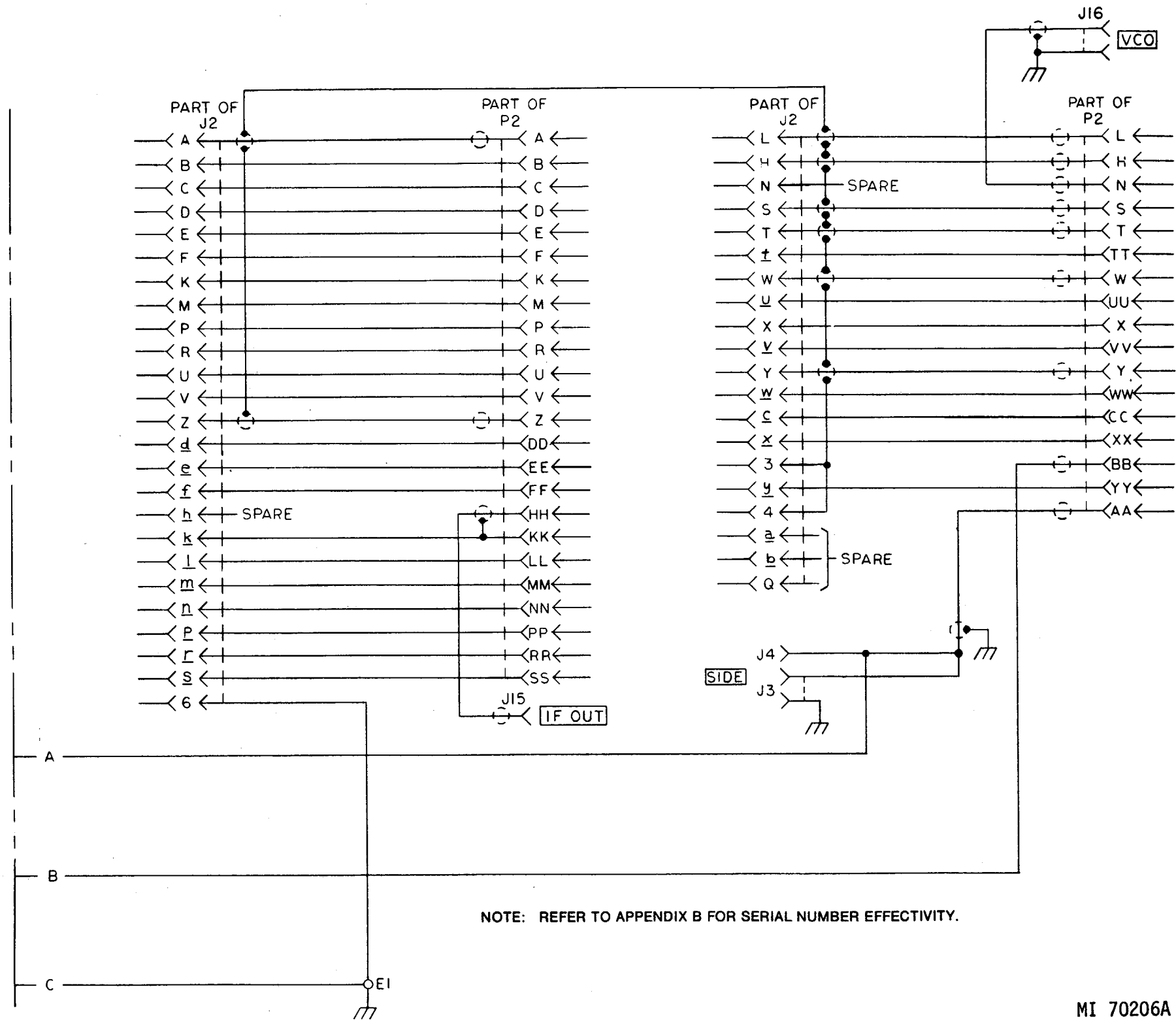

MI 70206A

Figure 3-222. Unit adapter UA8-1040 10671782* (AB) (FG 3160)- schematic (sheet 2 of 2).

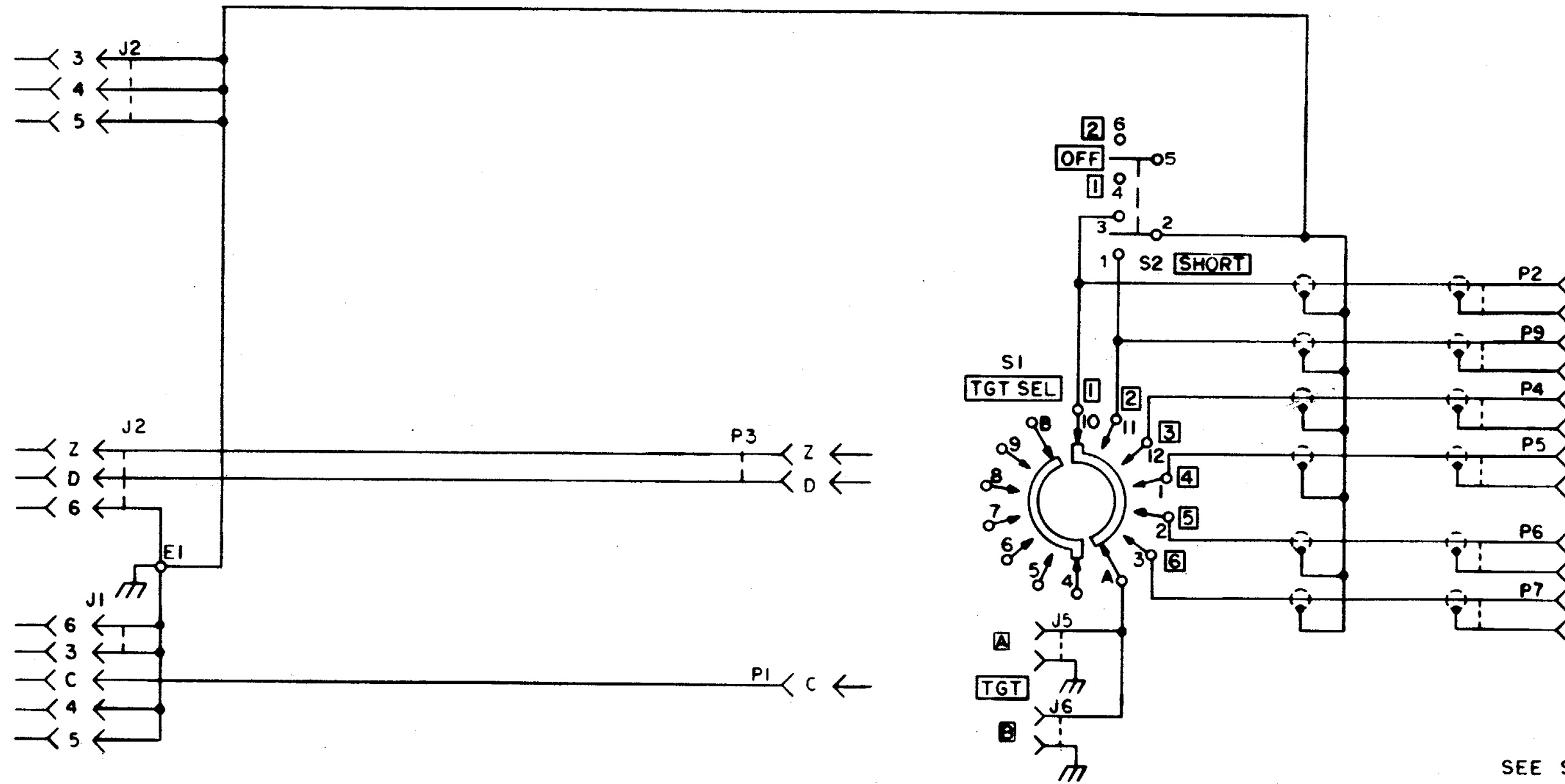

SEE SHEET 2

MI 70208B

Figure 3-223. Unit adapter UA8-1043A 10288116) (FG 3200)- schematic (sheet 1 of 2).

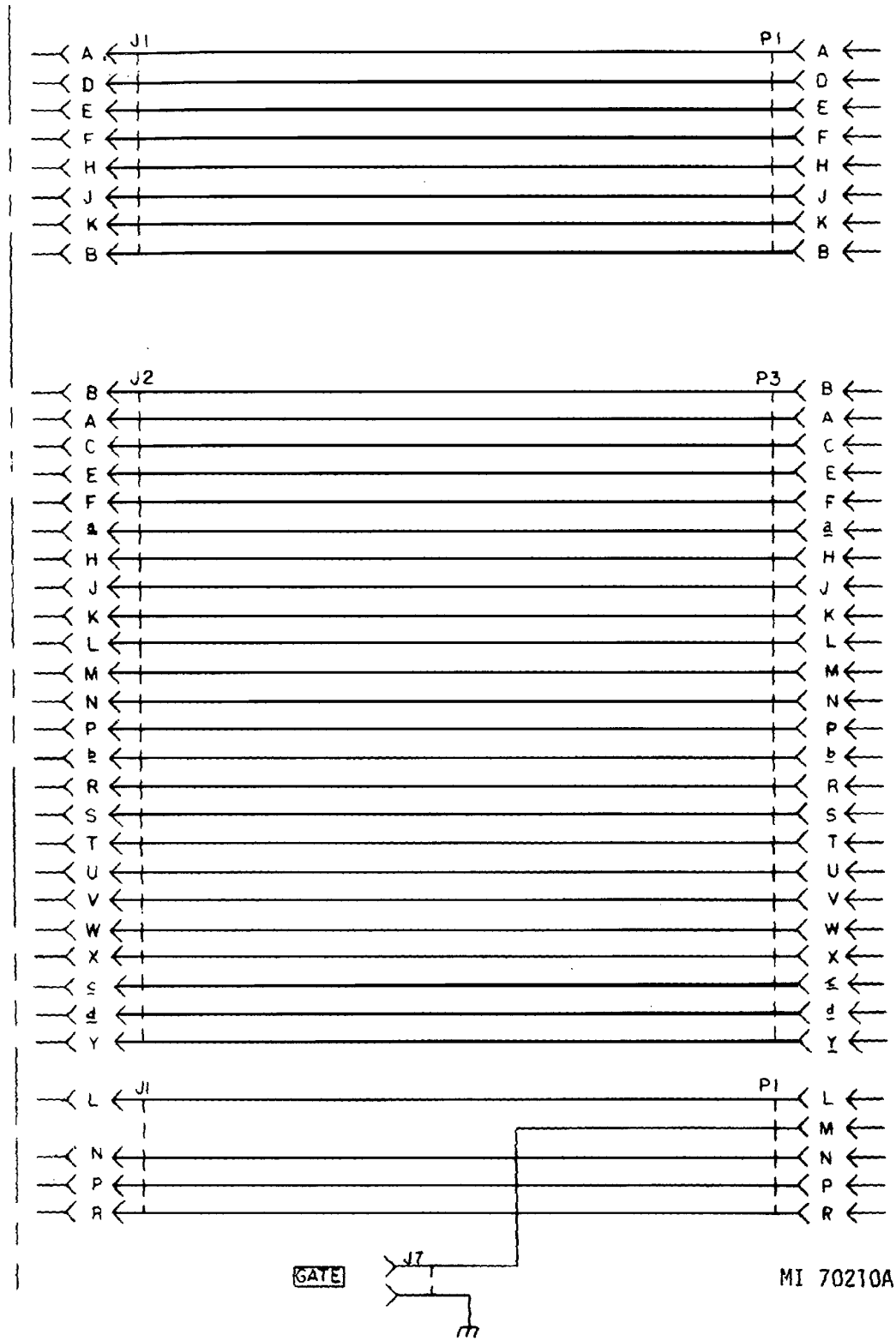

SEE SHEET 1

Figure 3-223. Unit adapter UA8-1043A 10288116 (FG 3200) - schematic (sheet 2 of 2).

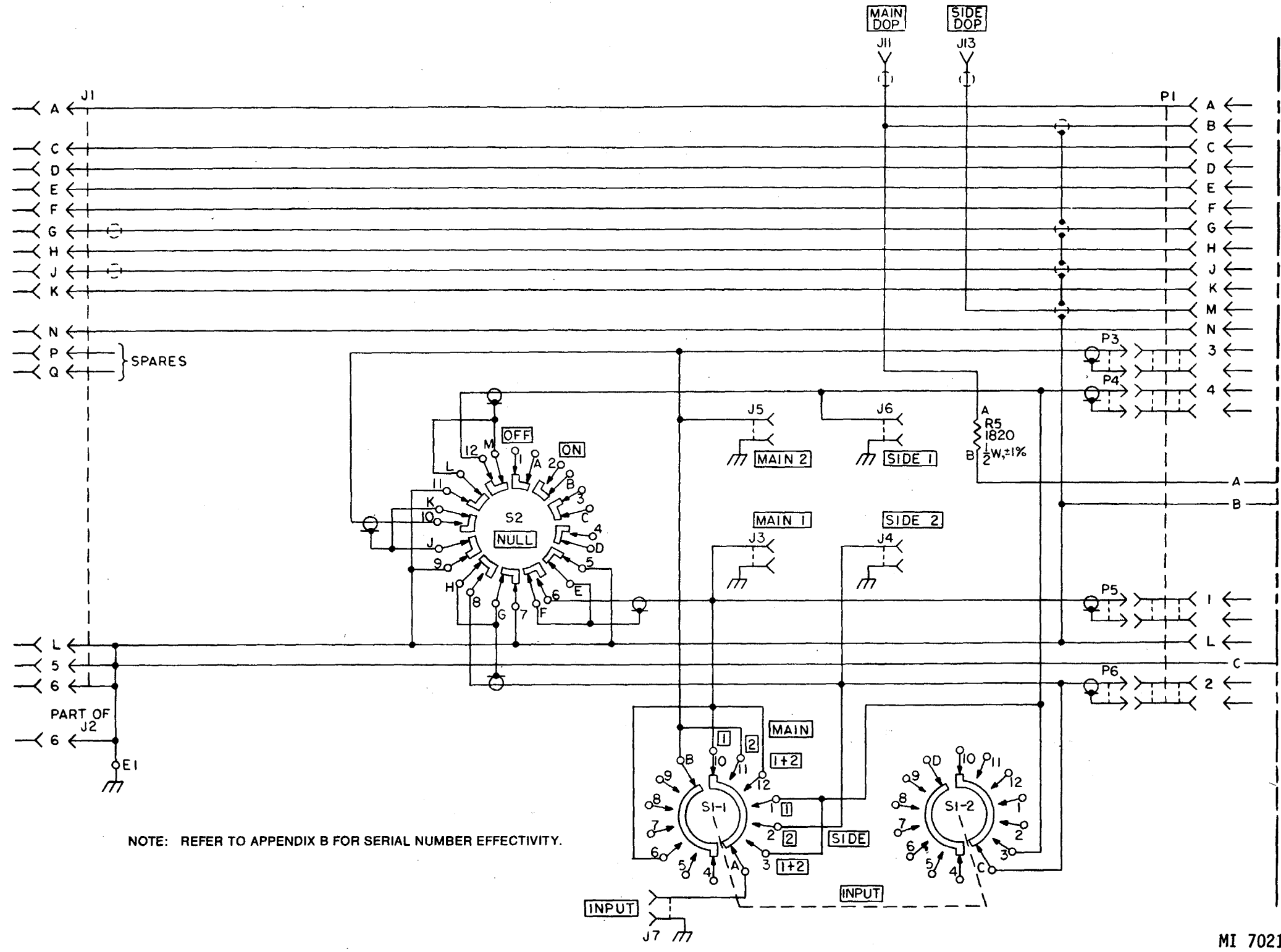
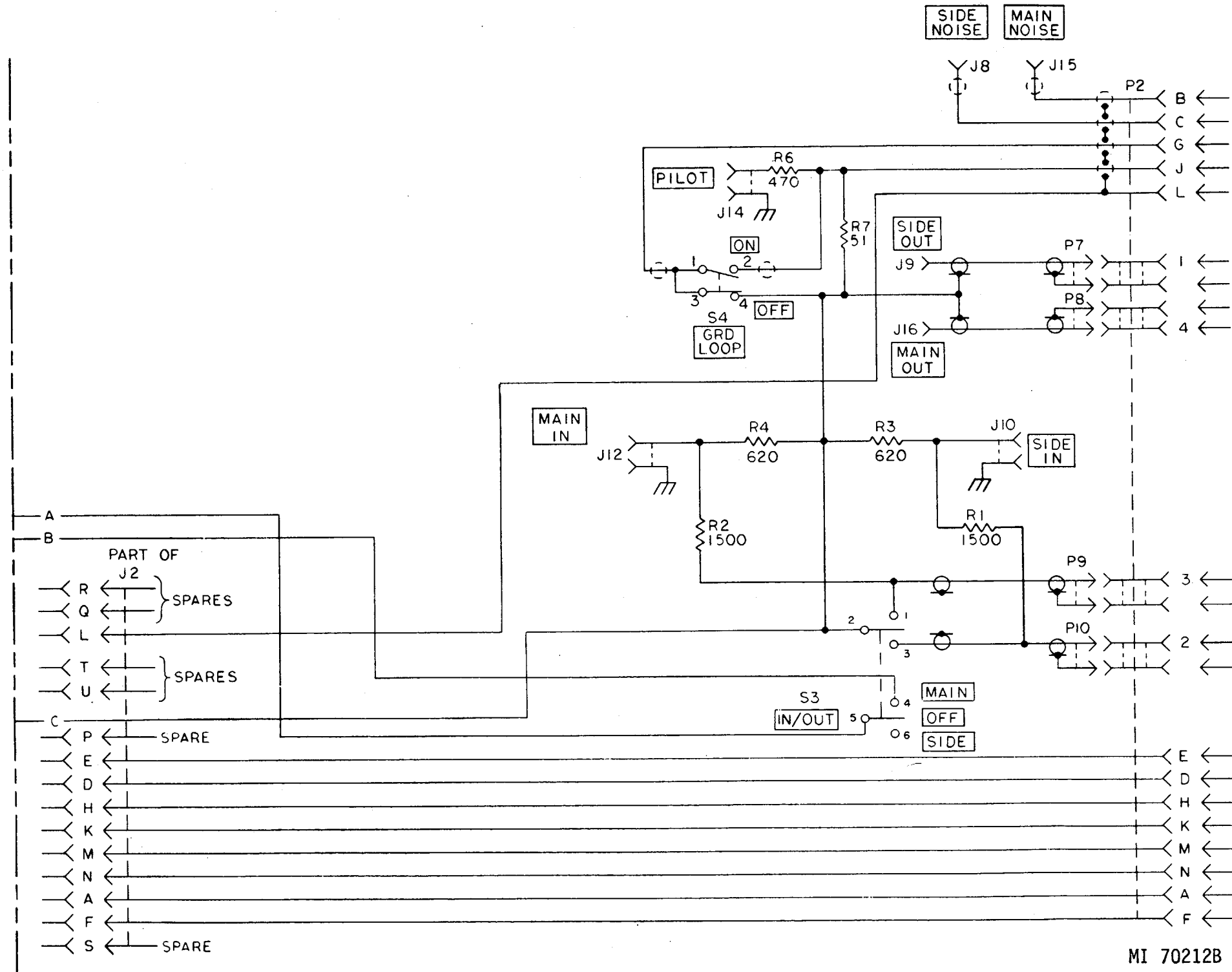
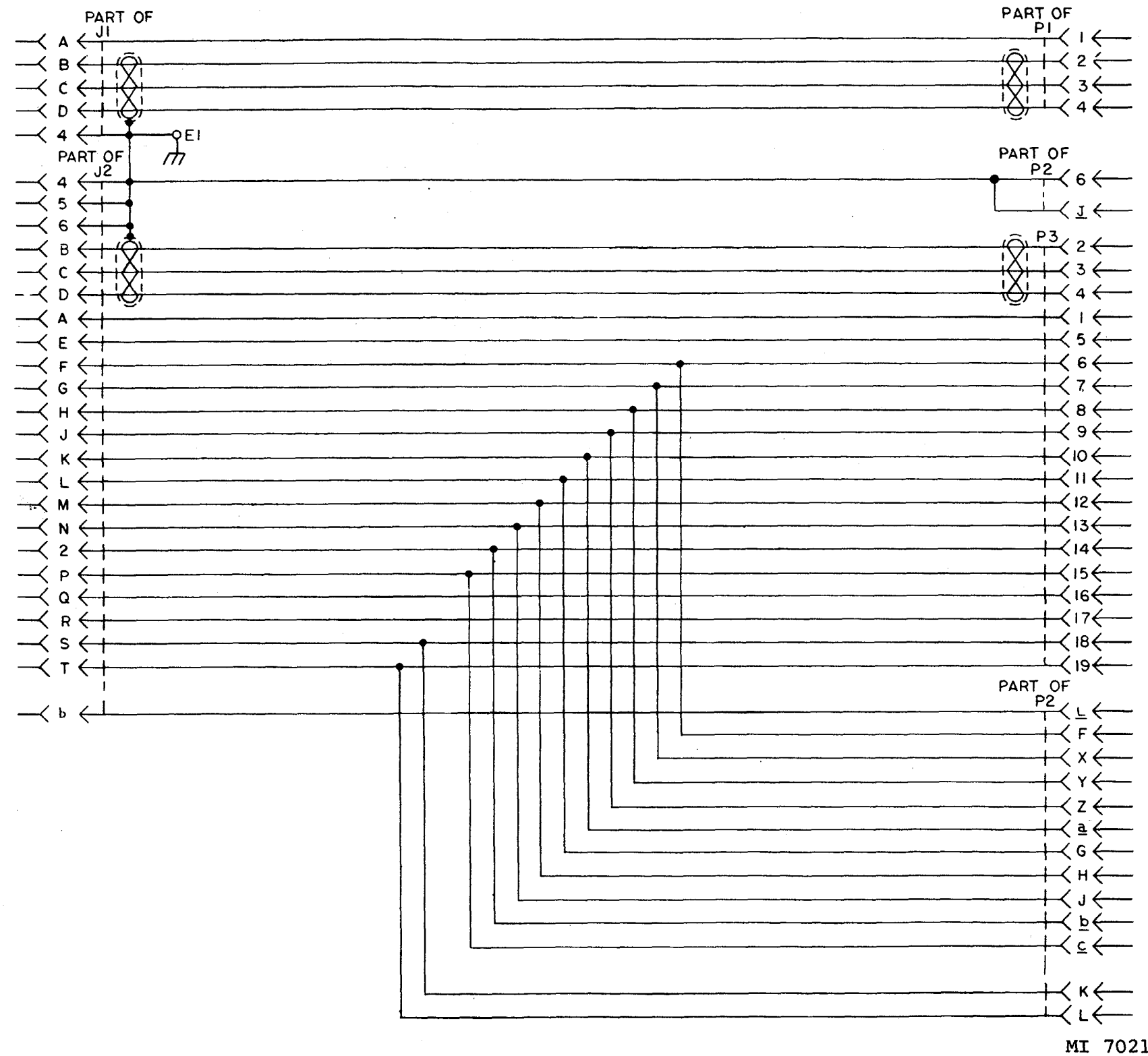

Figure 3-224. Unit adapter UA8-1044 10670521 *(AB) (see note) (FG 3220) - schematic (sheet 1 of 2).



NOTE: REFER TO APPENDIX B FOR SERIAL NUMBER EFFECTIVITY.

Figure 3-224. Unit adapter UA8-1044 10670521 *(AB) (see note) (FG 3220) - schematic (sheet 2 of 2).



MI 70213

Figure 3-225. Unit adapter UA8-105 10670511 (FG 3240) - schematic (sheet 1 of 2).

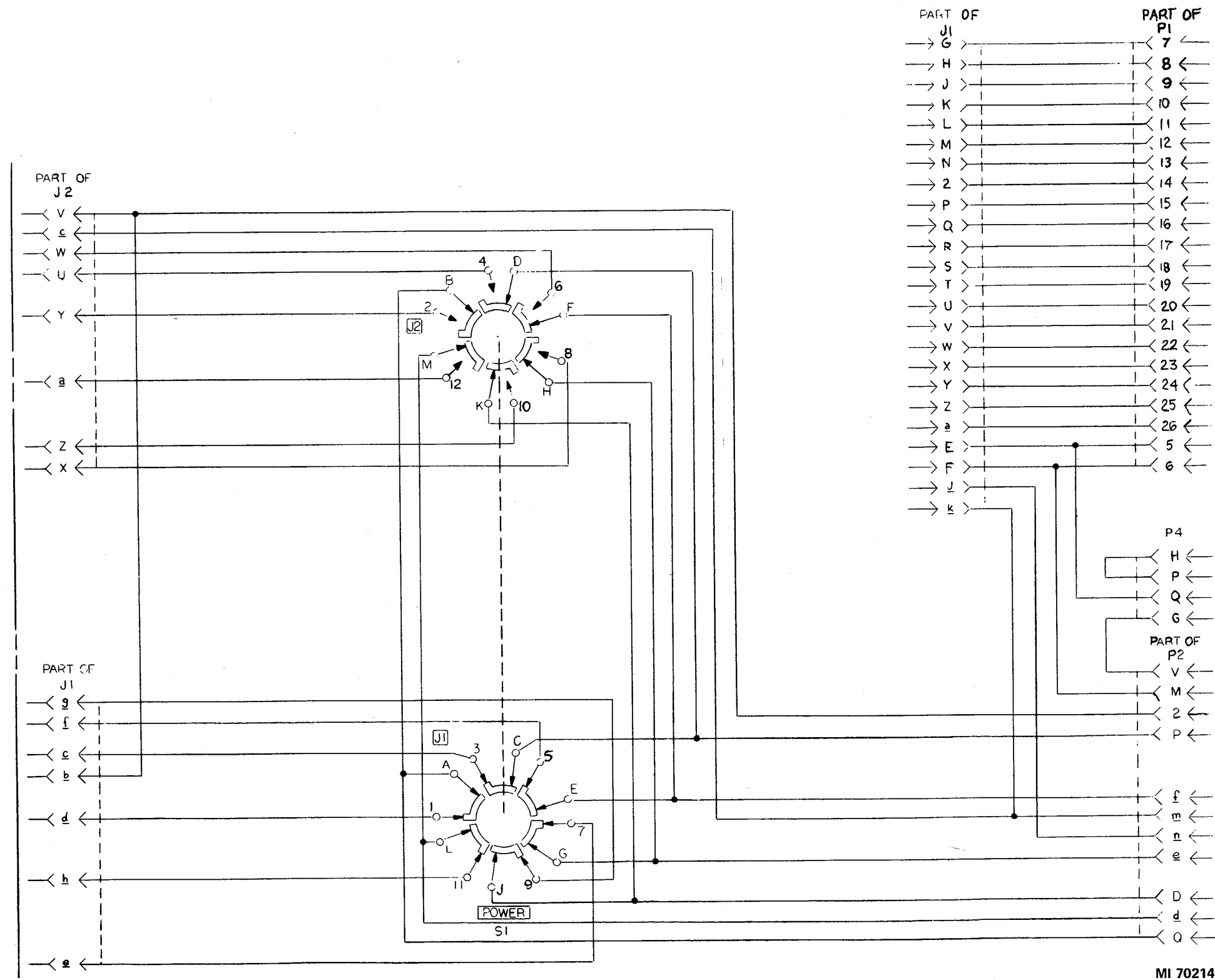

MI 70214

Figure 3-225. Unit adapter UA8-105 10670511 (FG 3240) - schematic (sheet 2 of 2).

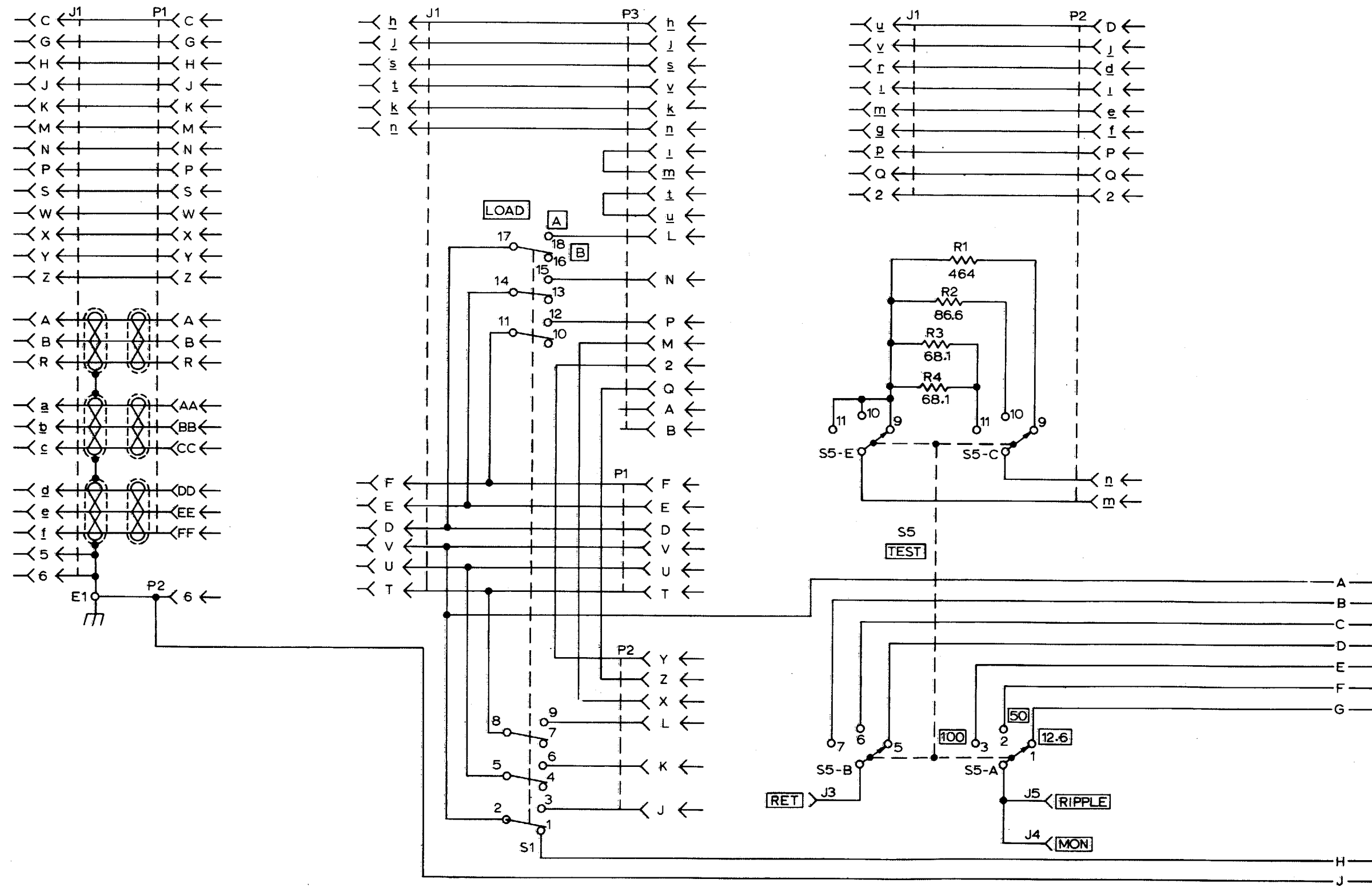

MI 70217

Figure 3-226. Unit adapter UA8-1048 10670615 (FG 3280) - schematic (sheet 1 of 2).

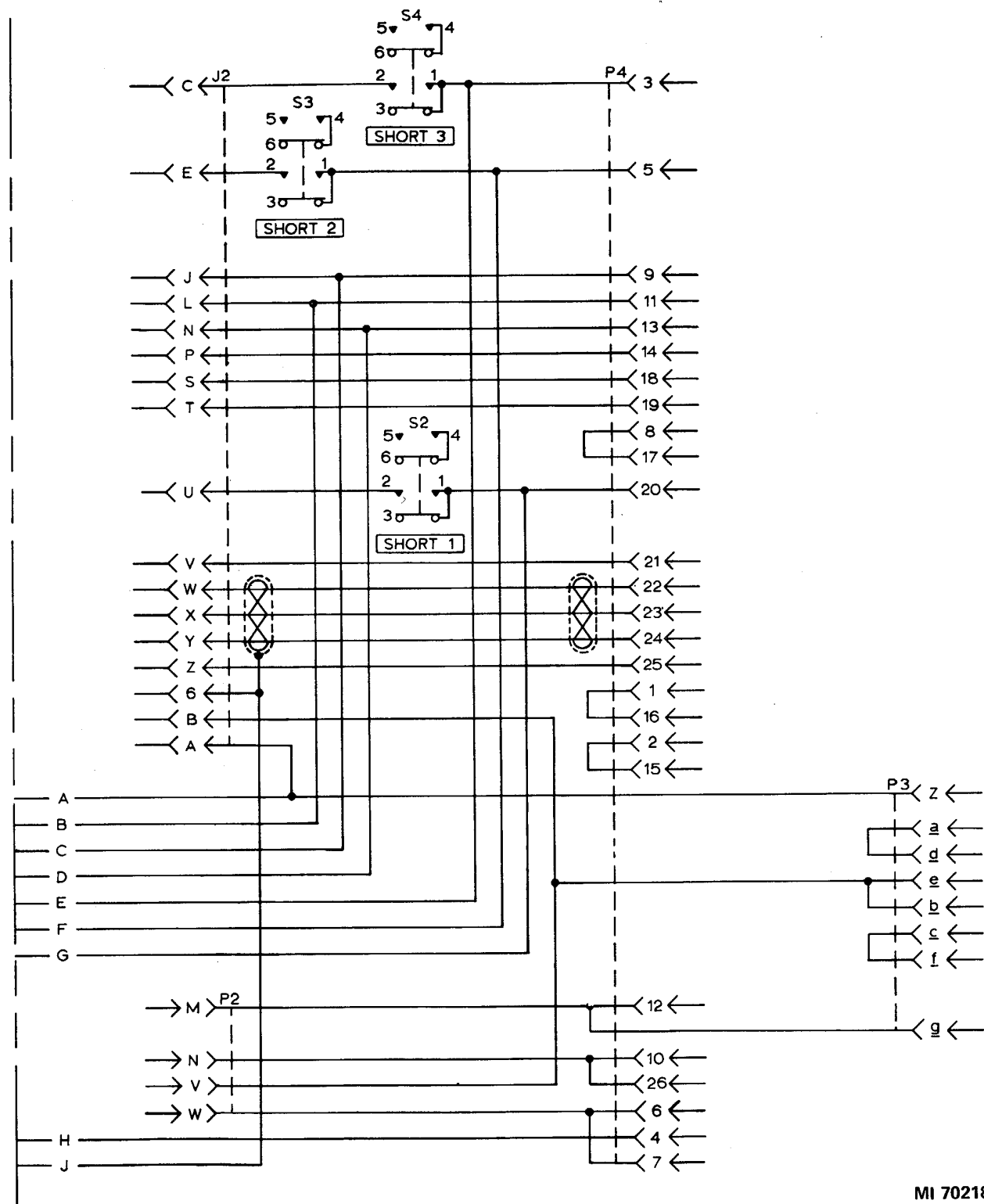

MI 70218

Figure 3-226. Unit adapter UA8-1048 10670615 (FG 3280) - schematic (sheet 2 of 2).

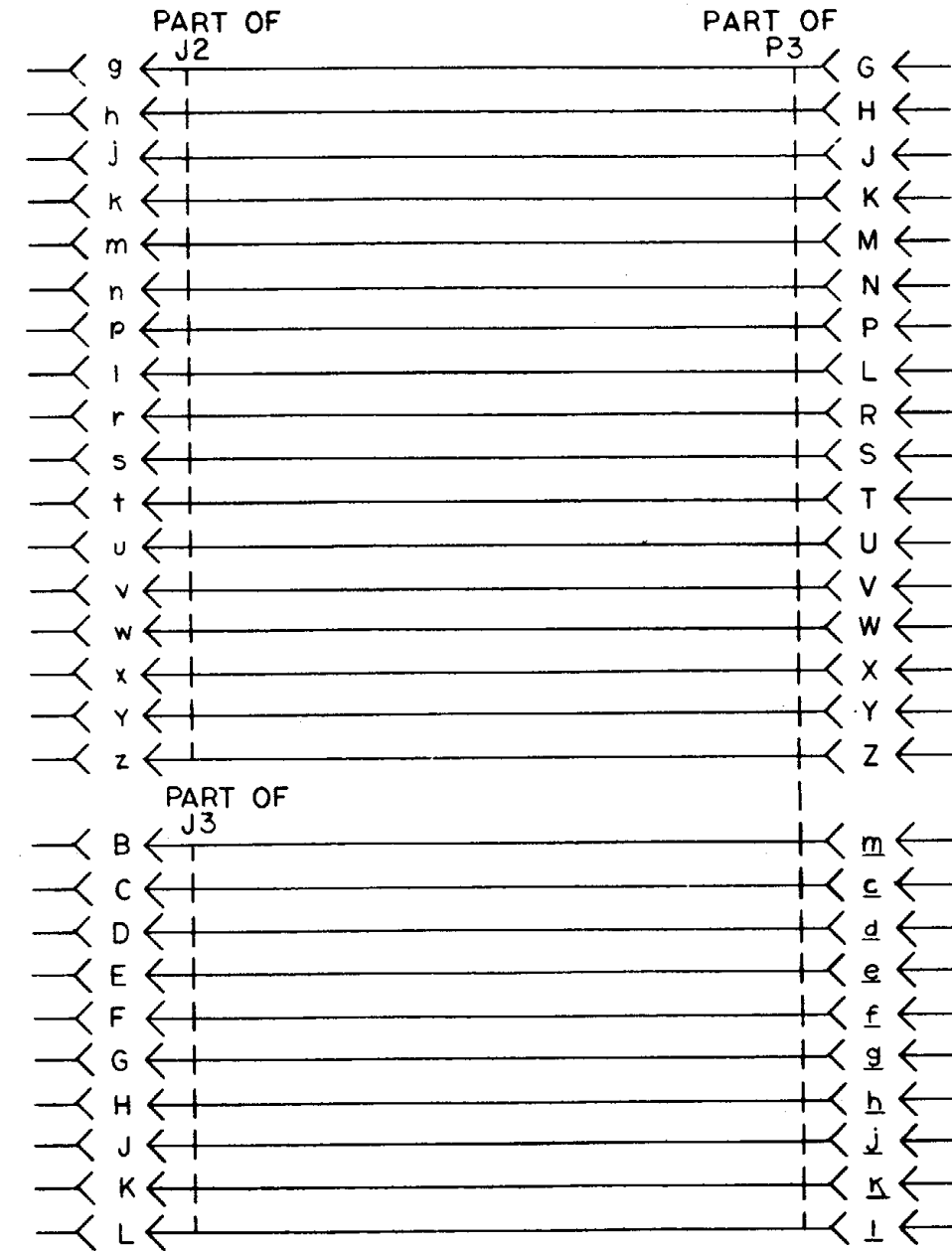
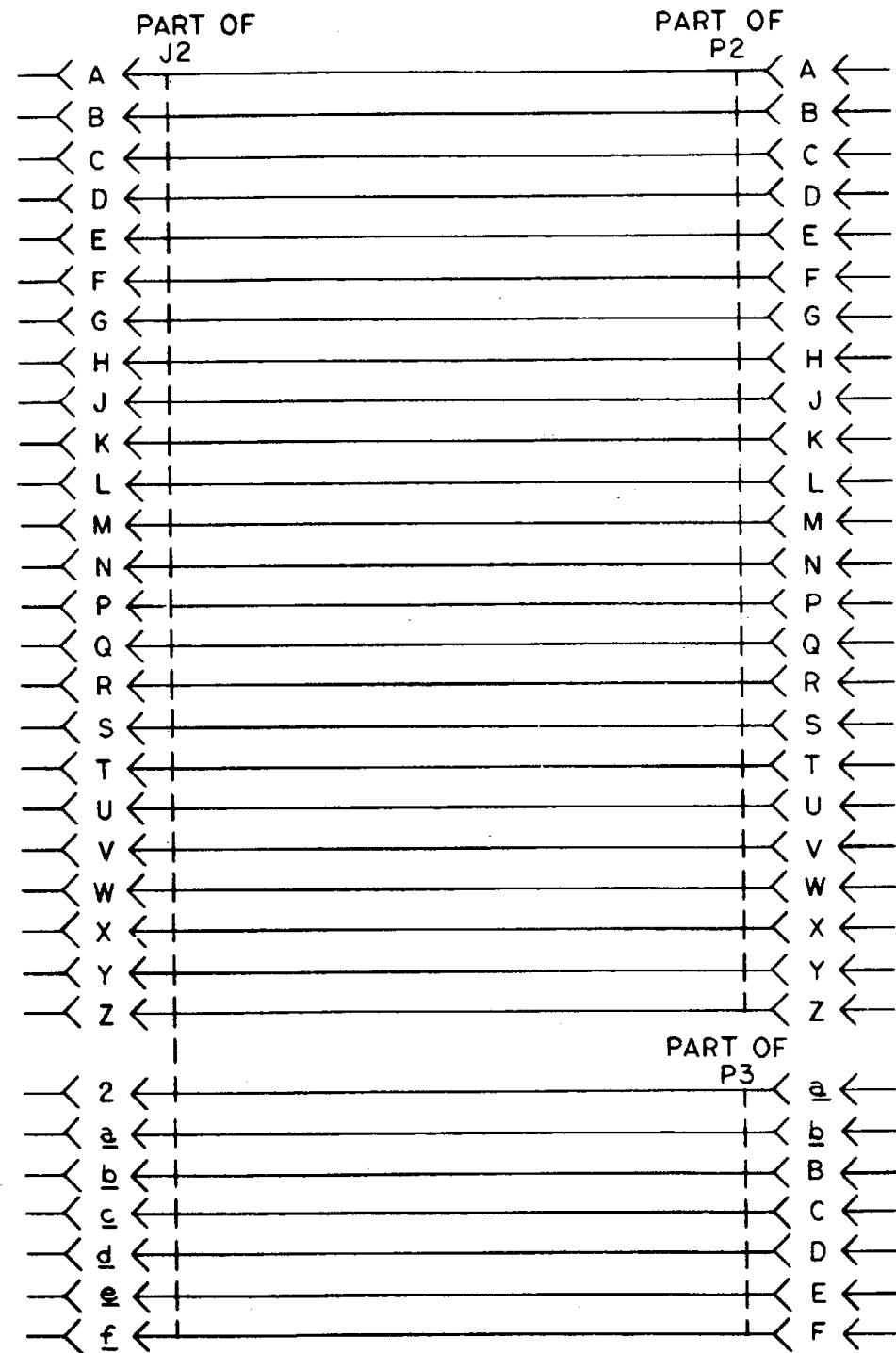

MI 70220

Figure 3-227. Unit adapter UA8-1049 10670515 (FG 3300) - schematic (sheet 2 of 2).

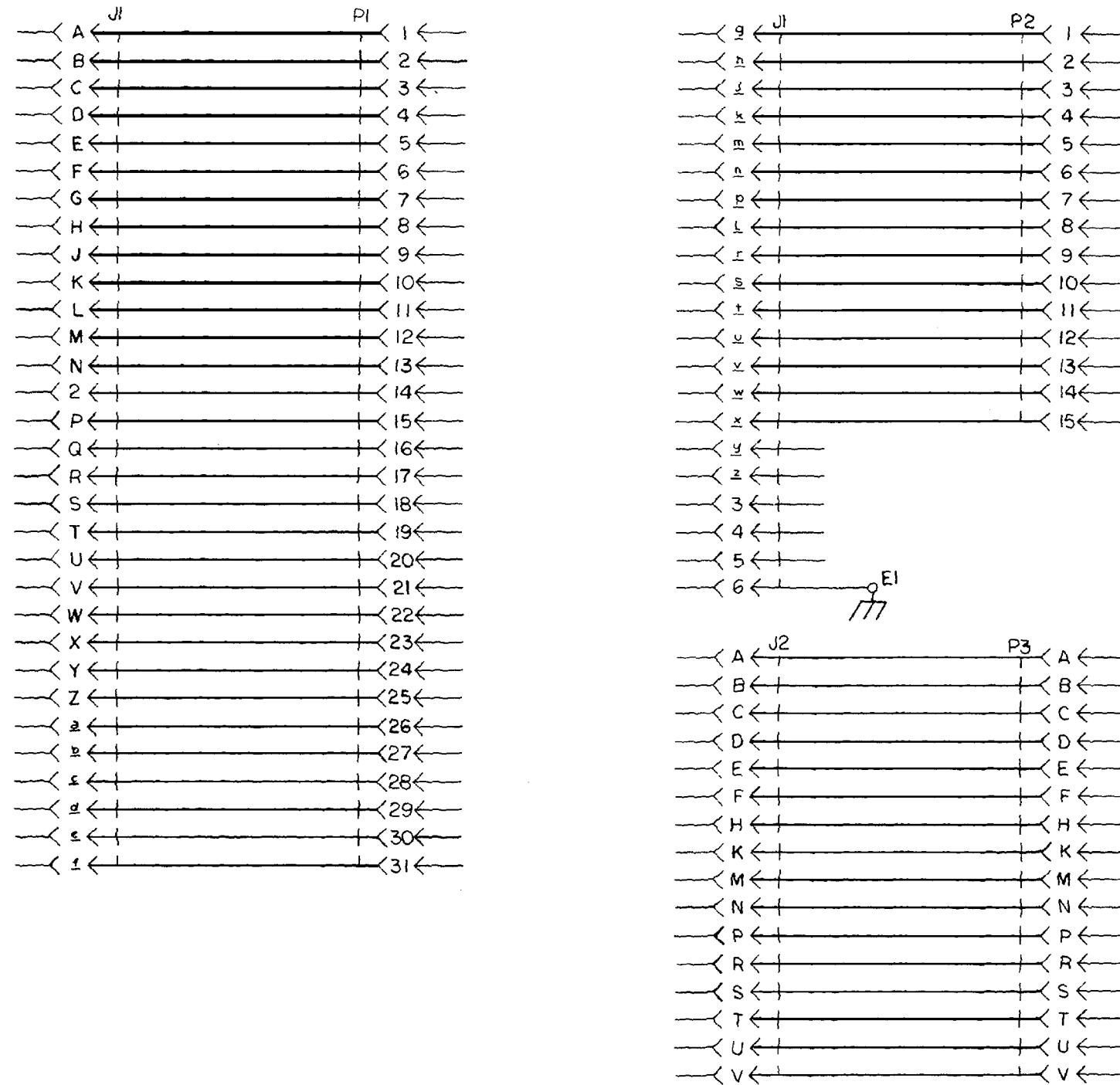

MI 70223A
SEE SHEET 2

Figure 3-228. Unit adapter UA8-1050A 10669039 (FG 1584) - schematic (sheet 1 of 2).

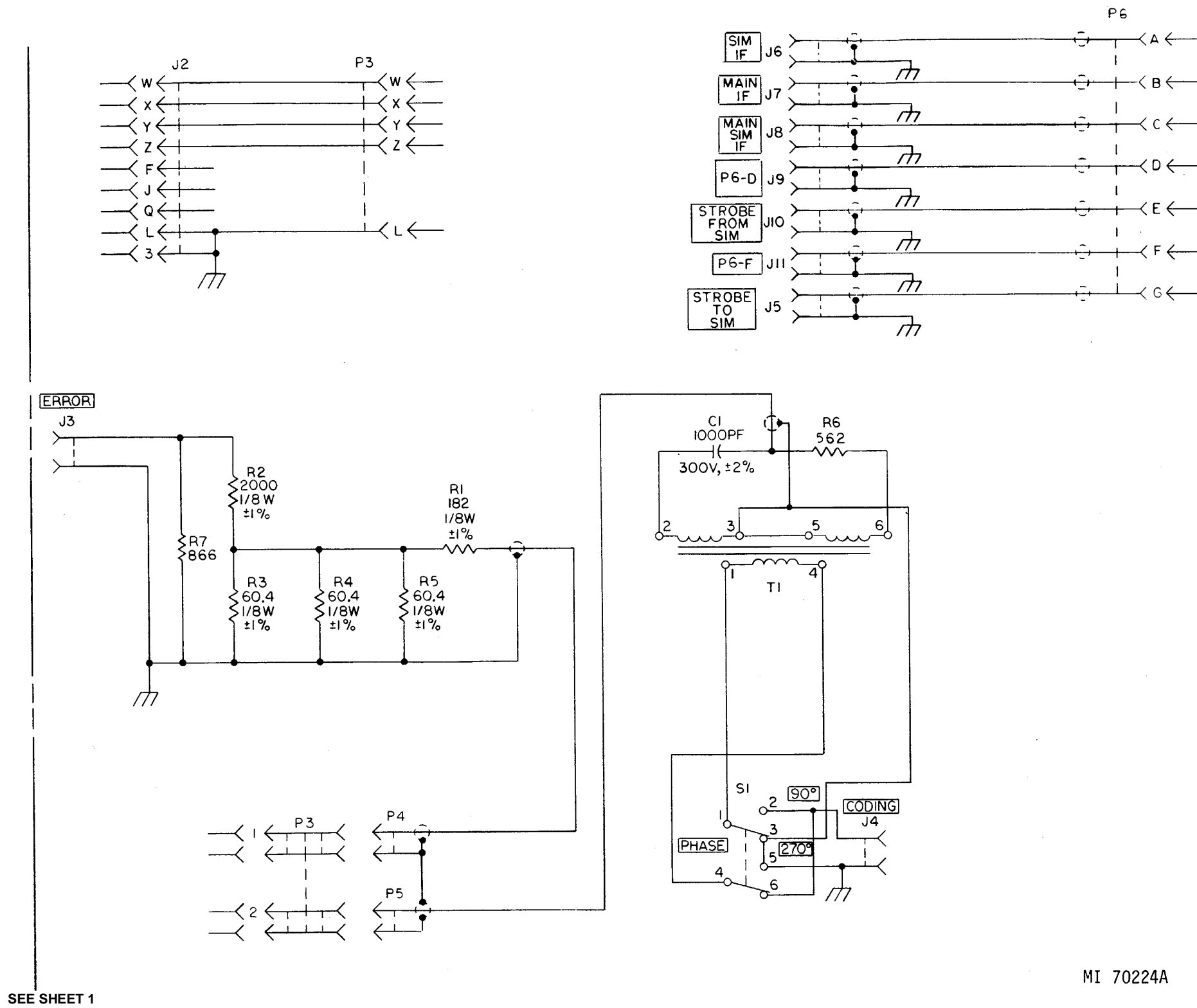

SEE SHEET 1

MI 70224A

Figure 3-228. Unit adapter UA8-1050A 10669039 (FG 1584) - schematic (sheet 2 of 2).

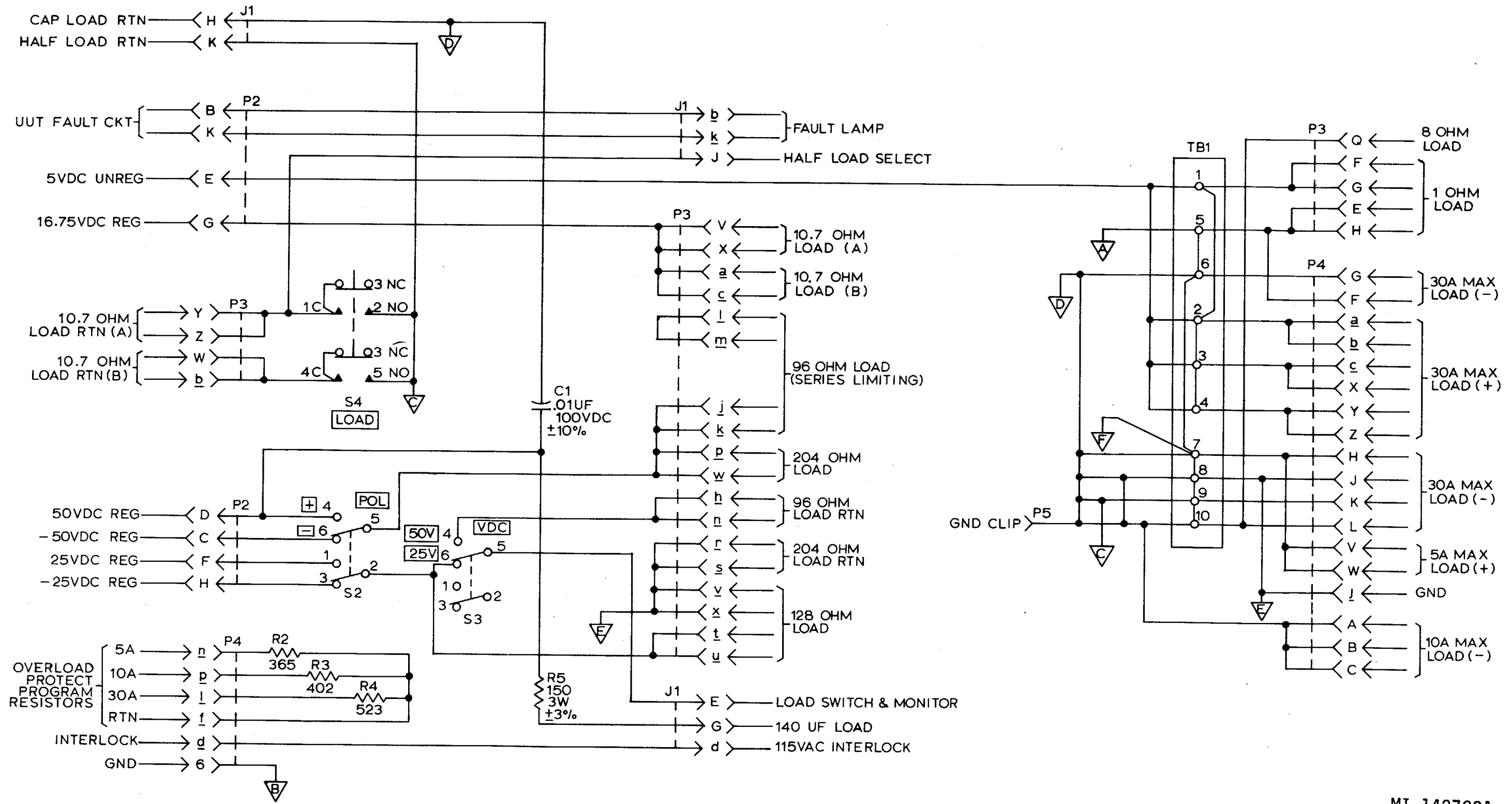

MI 142790A

Figure 3-230. Unit adapter UA8-1052B 10288587 (FG 3360) - schematic (sheet 1 of 2).

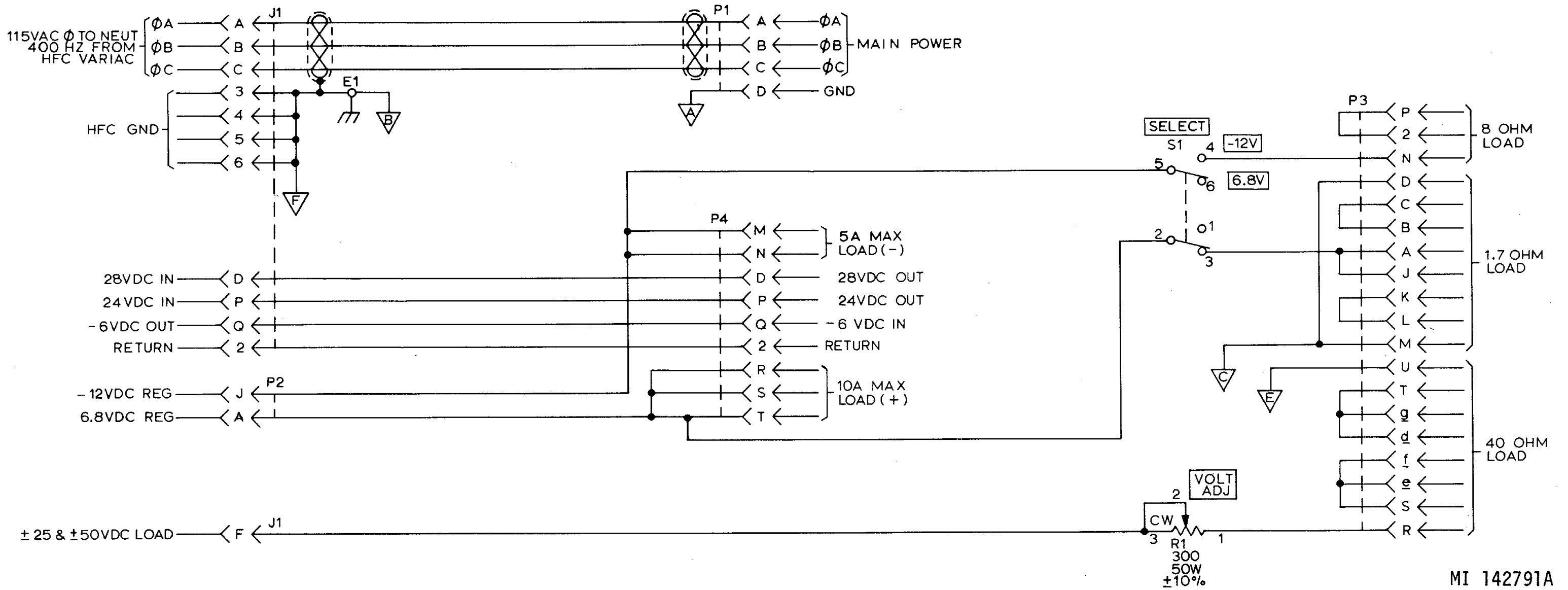

MI 142791A

Figure 3-230. Unit adapter UA8-1052B 10288587 (FG 3360) - schematic (sheet 2 of 2).

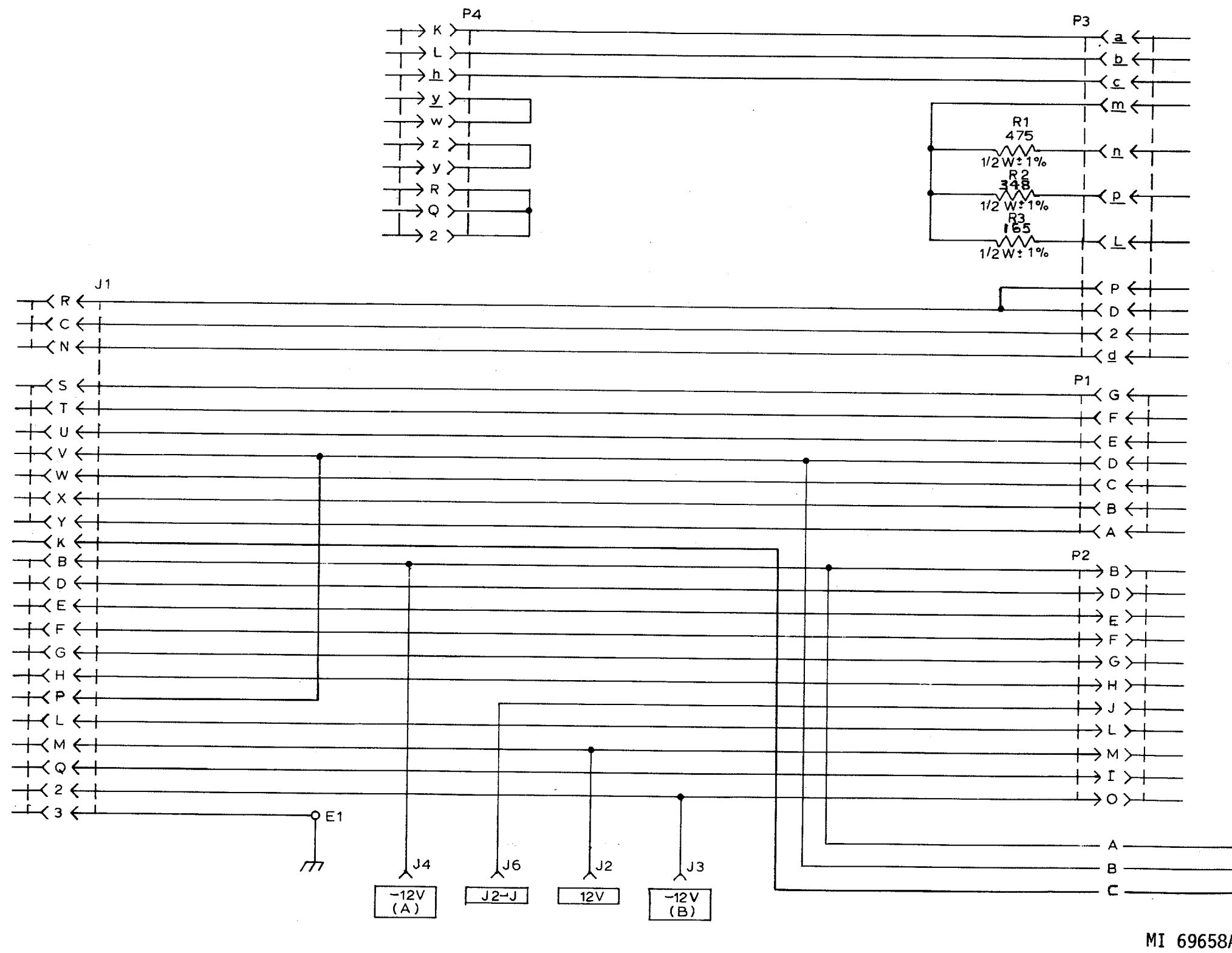

MI 69658A

Figure 3-231. Unit adapter UA8-1053B 10288588 (FG 3380) - schematic (sheet 1 of 2).

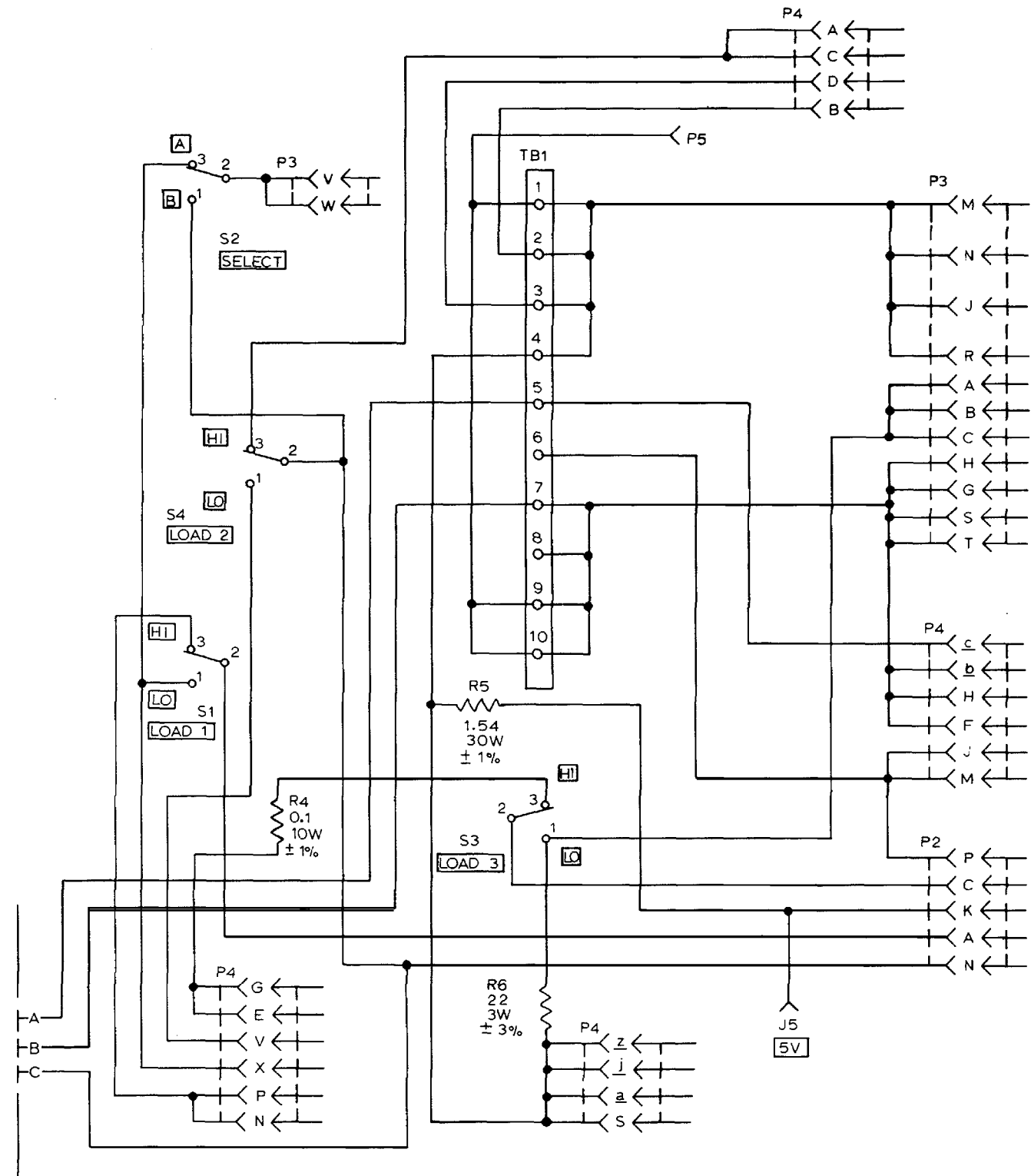

MI 69659D

Figure 3-231. Unit adapter UA8-1053B 10288588 (FG 3380) - schematic (sheet 1 of 2).

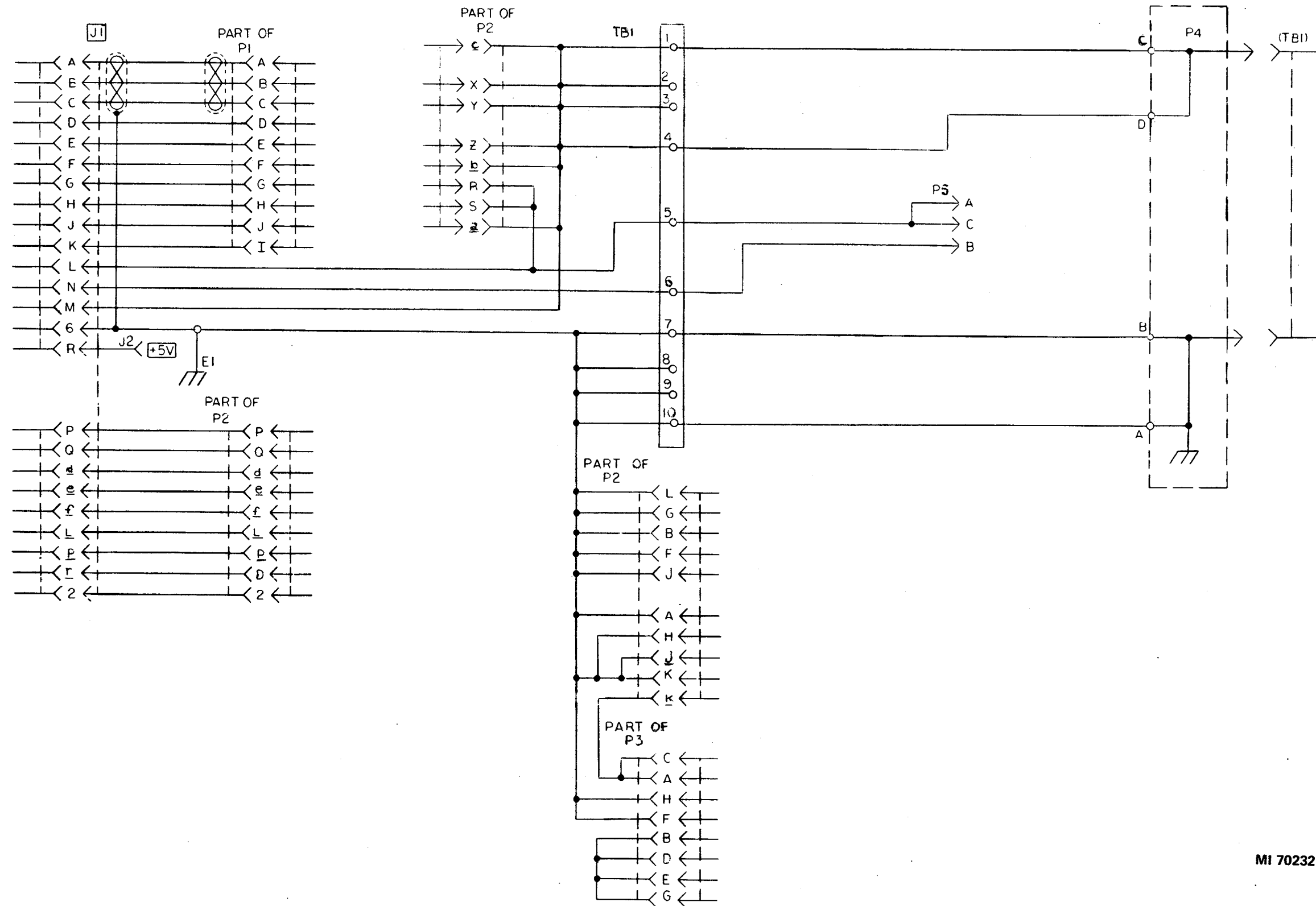

MI 70232

Figure 3-232. Unit adapter UA8-1055 10671786 (FG 3400) - schematic.

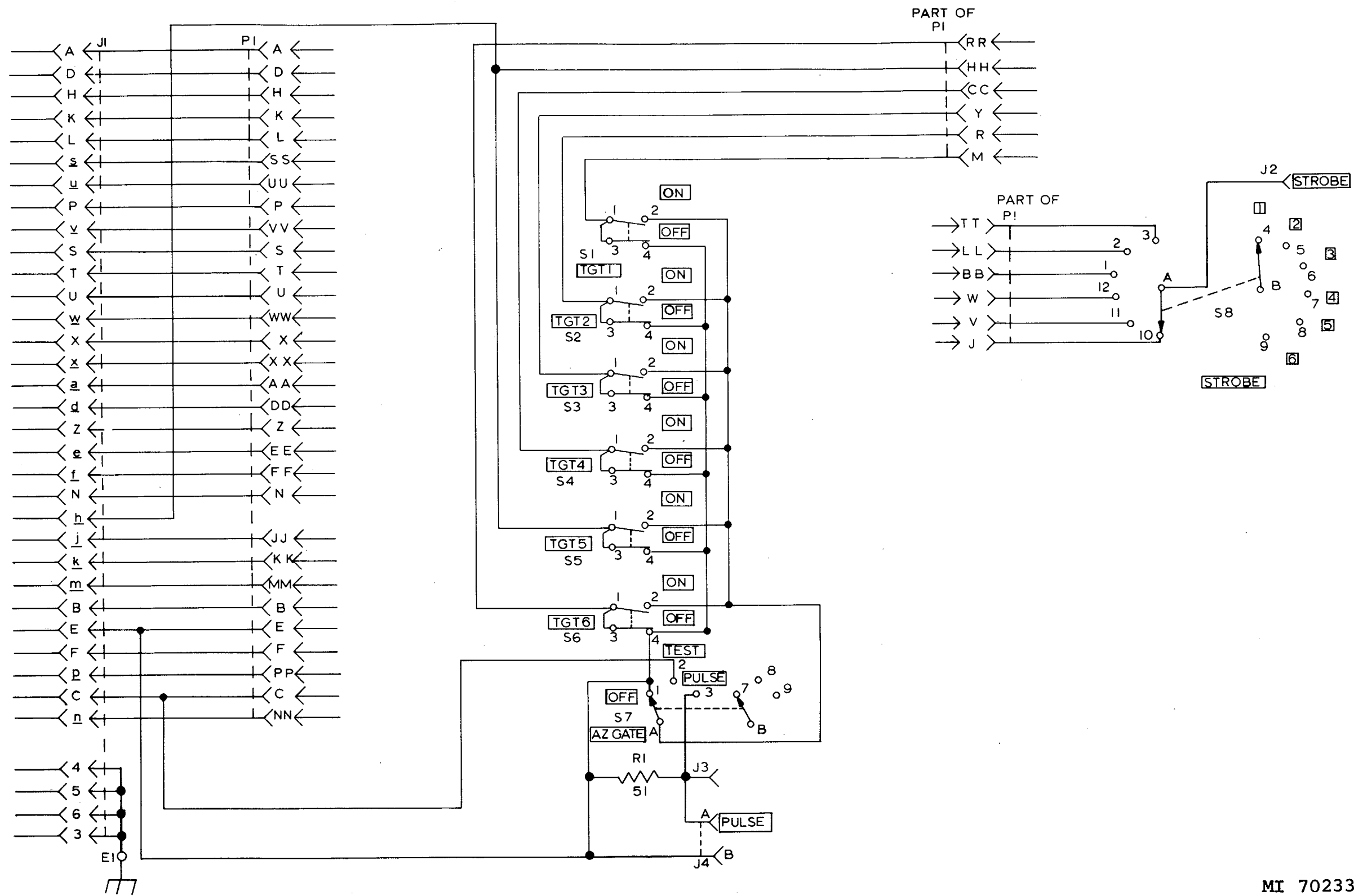
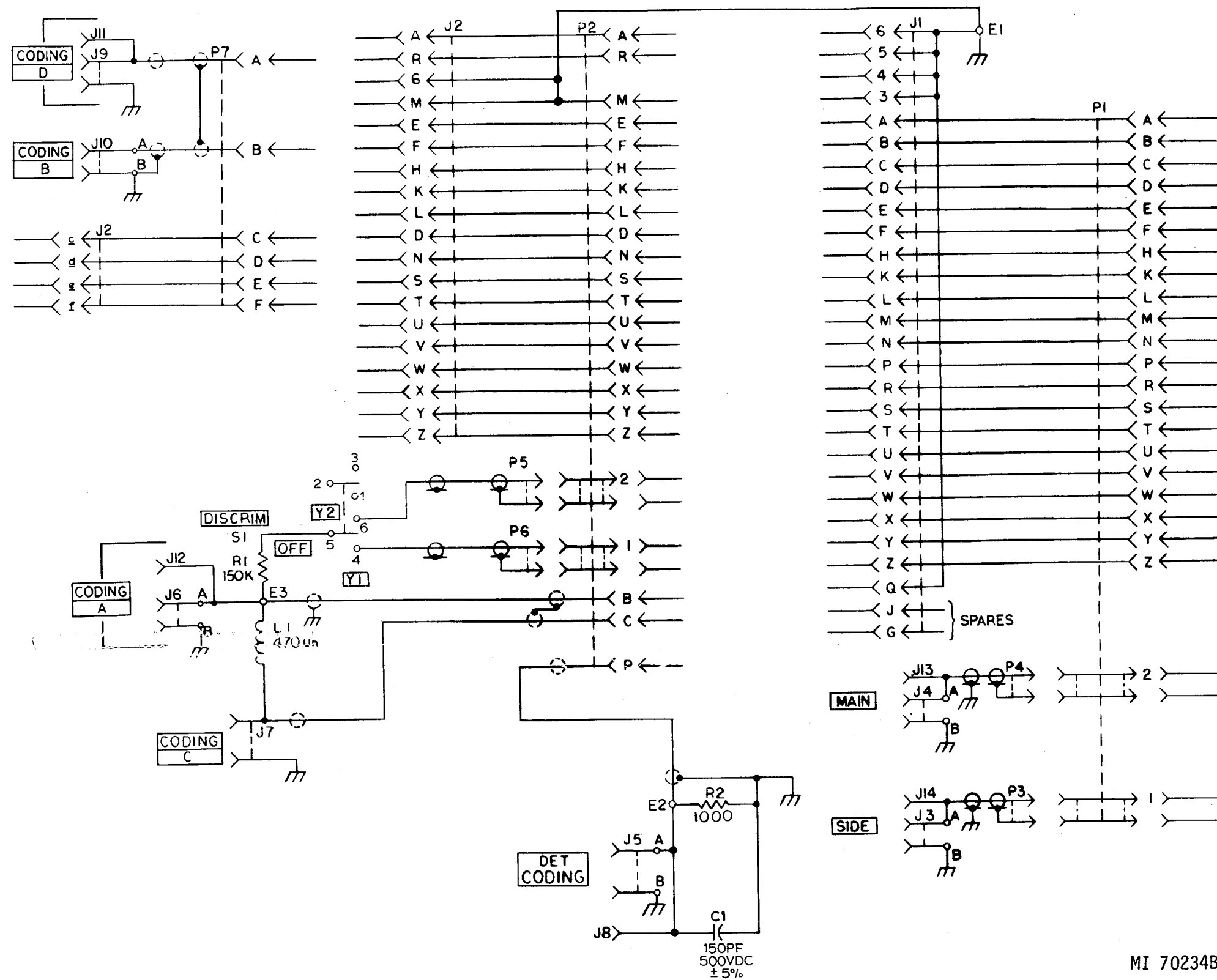

Figure 3-233. Unit adapter UA8-1056 10671787 (FG 3420) - schematic.

MI 70233



MI 70234B

Figure 3-234. Unit adapter UA8-1057A 10288119 (FG 3440) - schematic.

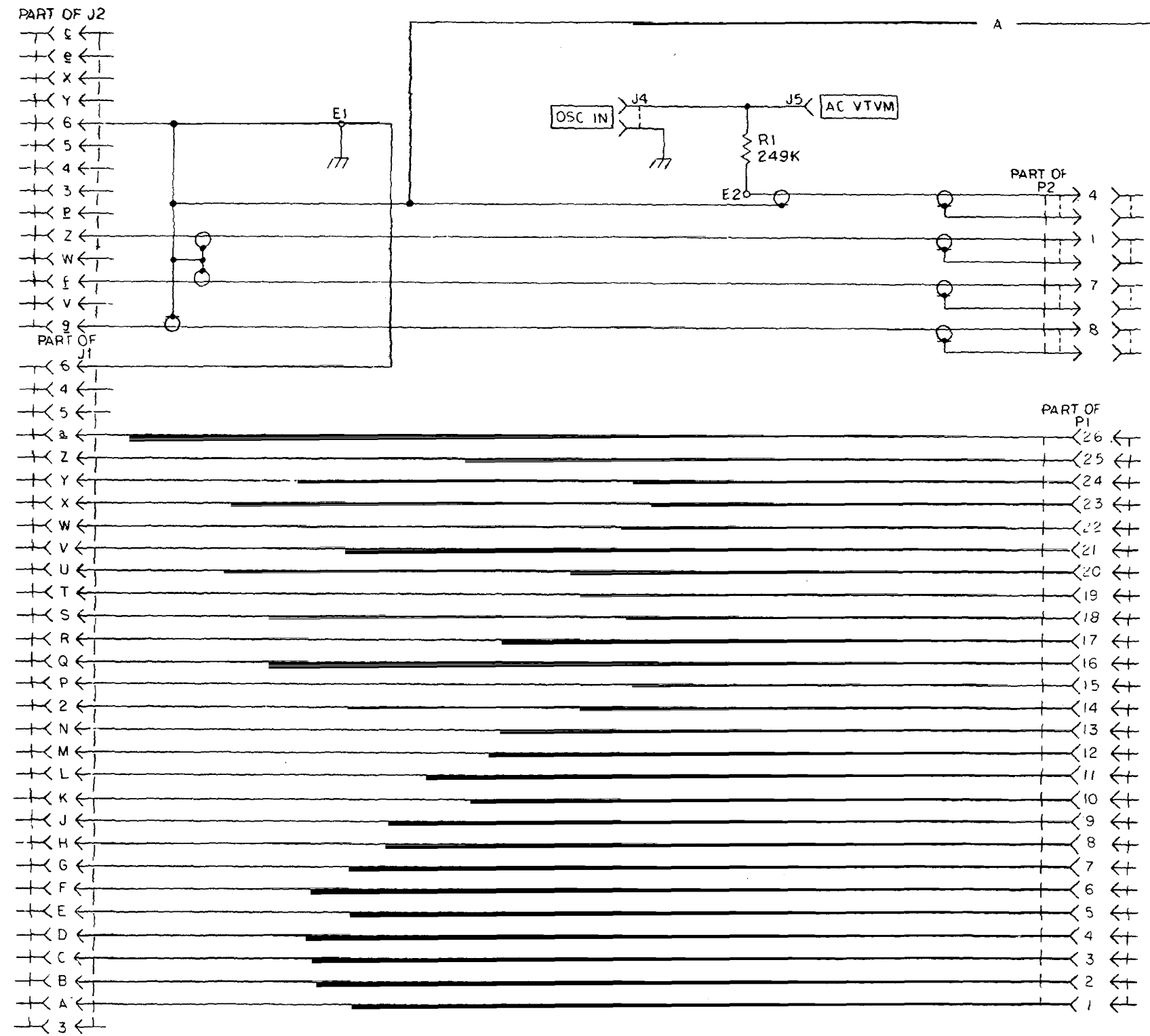

MI 70236

SEE SHEET 2

Figure 3-235. Unit adapter UA8-1058 10671788 (FG 3460) - schematic (sheet 1 of 2).

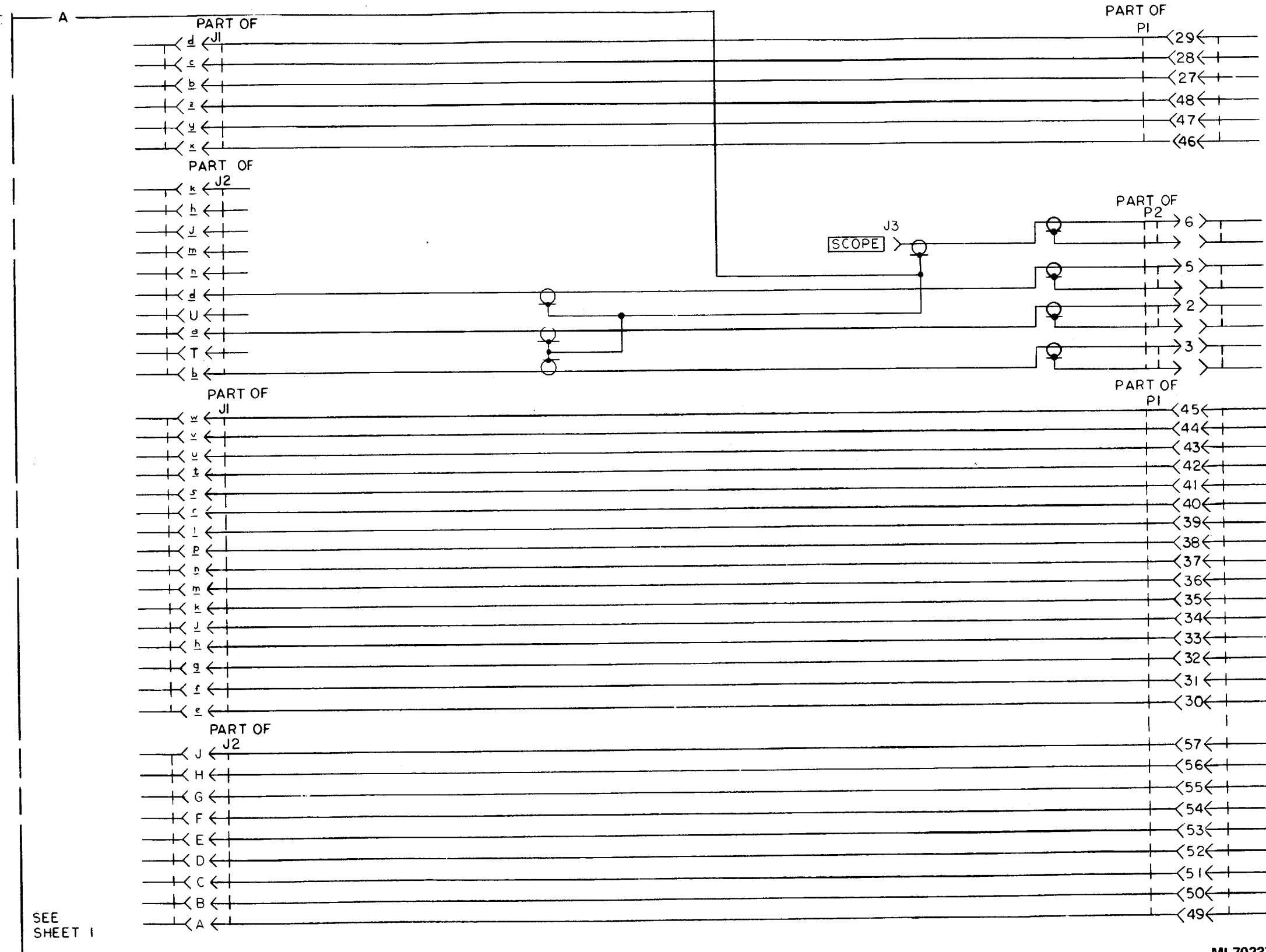

SEE SHEET 1

MI 70237

Figure 3-235. Unit adapter UA8-1058 10671788 (FG 3460)-schematic (sheet 2 of 2)

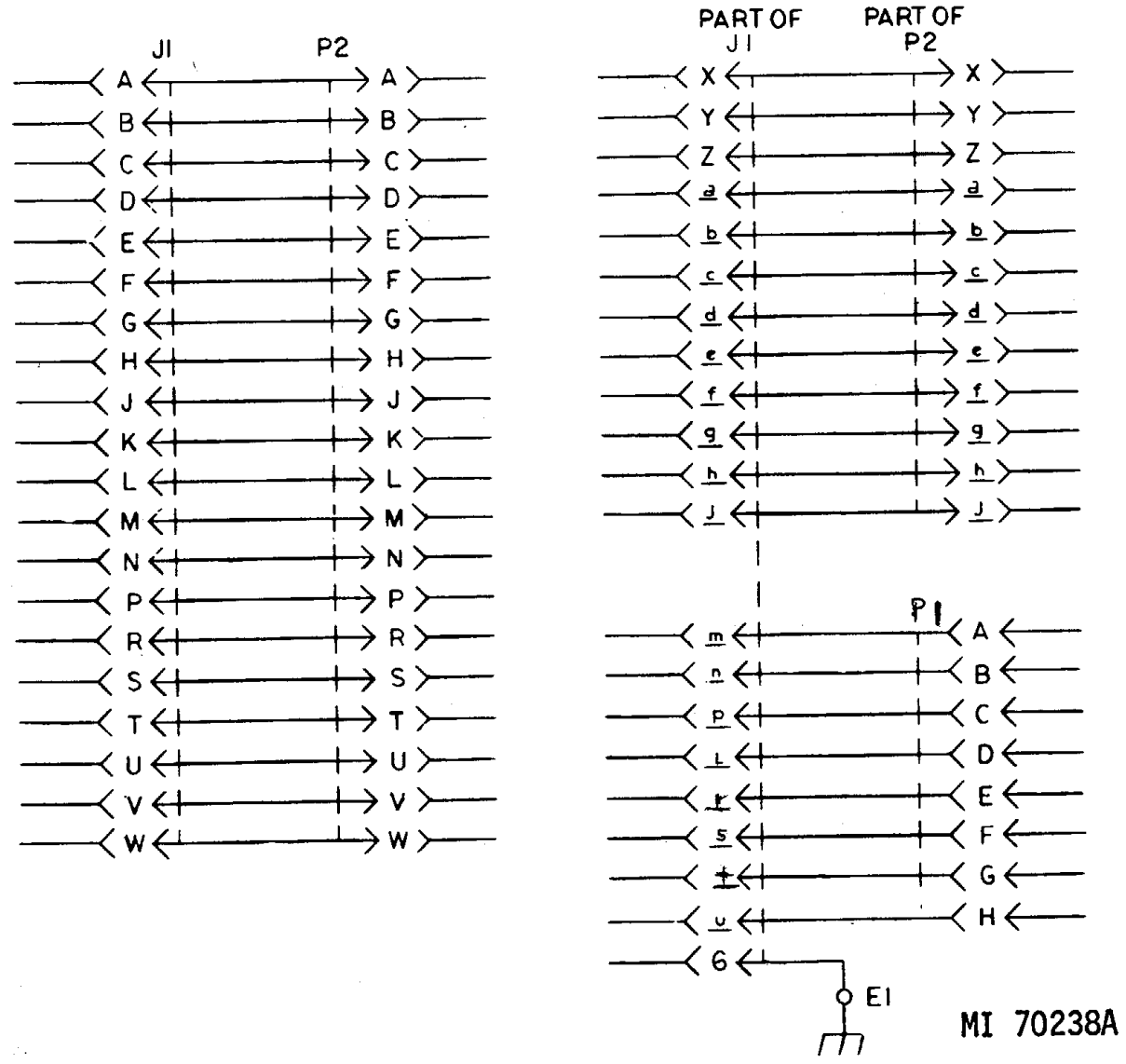

NOTE: REFER TO APPENDIX B FOR SERIAL NUMBER EFFECTIVITY.

Figure 3-236. Unit adapter UA8-1059 10671639 *(W) (see note) (FG 3480)-schematic.

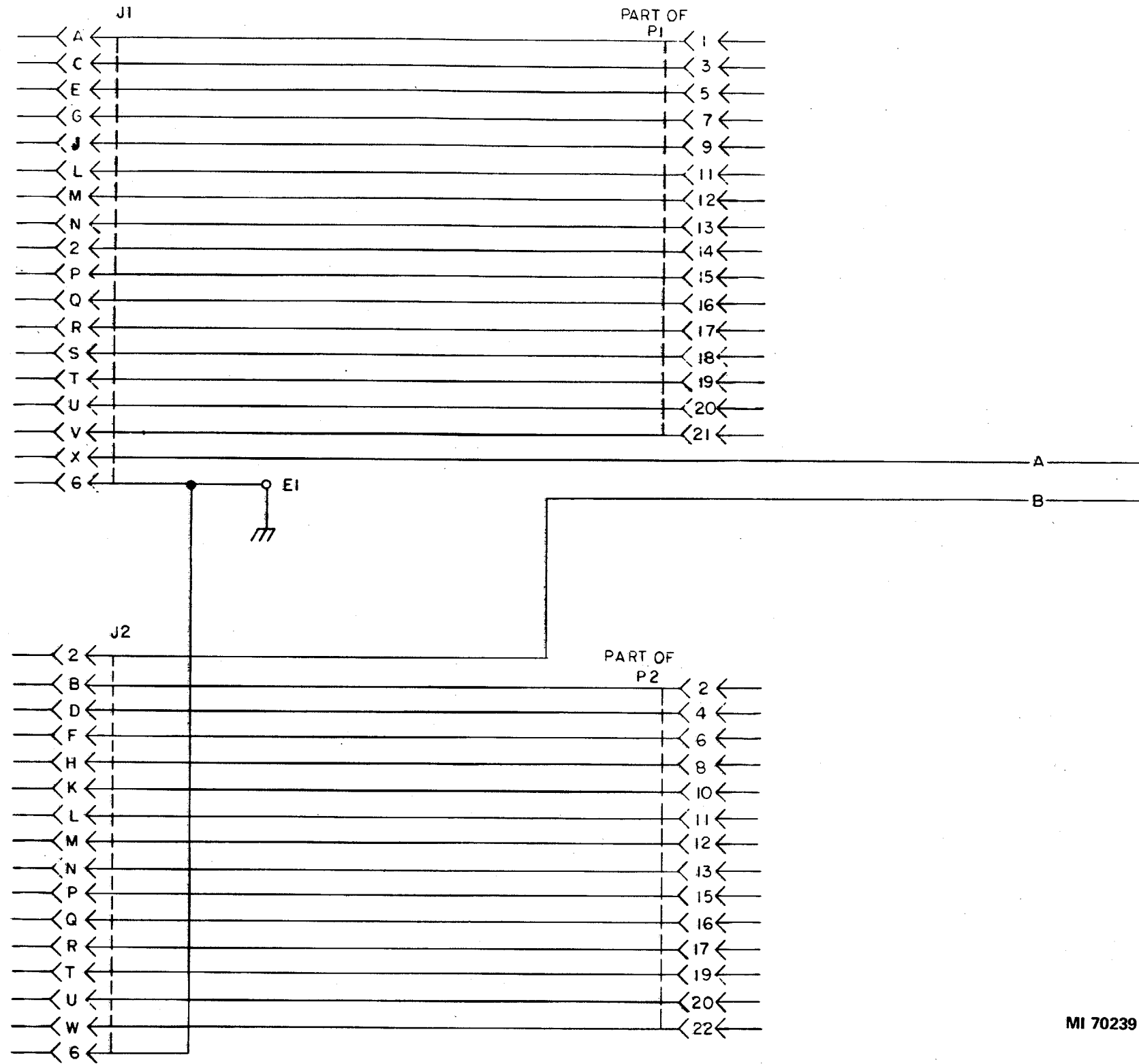

MI 70239

Figure 3-237. Unit adapter UA8-1060 10671789 (FG 3560)-schematic (sheet 1 of 2)

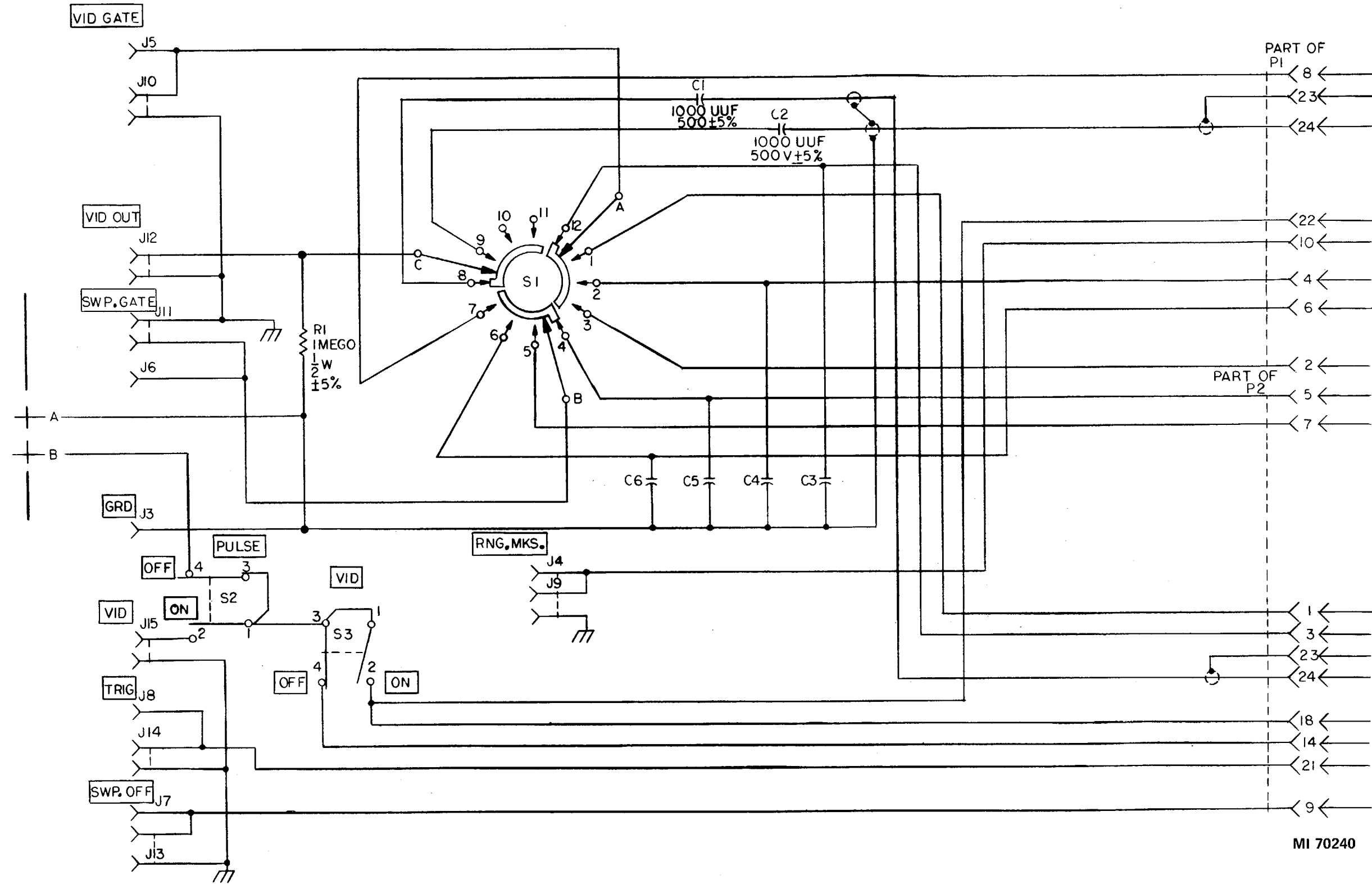

MI 70240

Figure 3-237. Unit adapter UA8-1060 10671789 (FG 3560)-schematic (sheet 2 of 2)

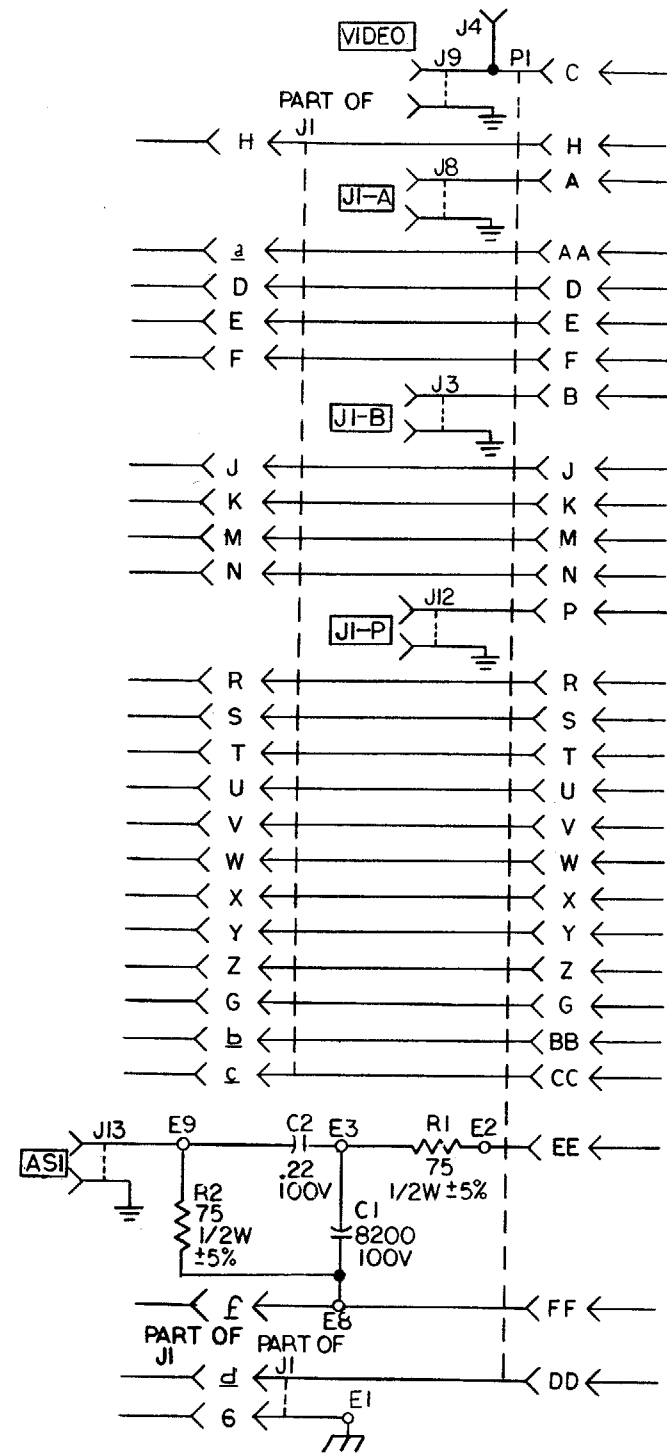

NOTE: REFER TO APPENDIX B FOR SERIAL NUMBER EFFECTIVITY.

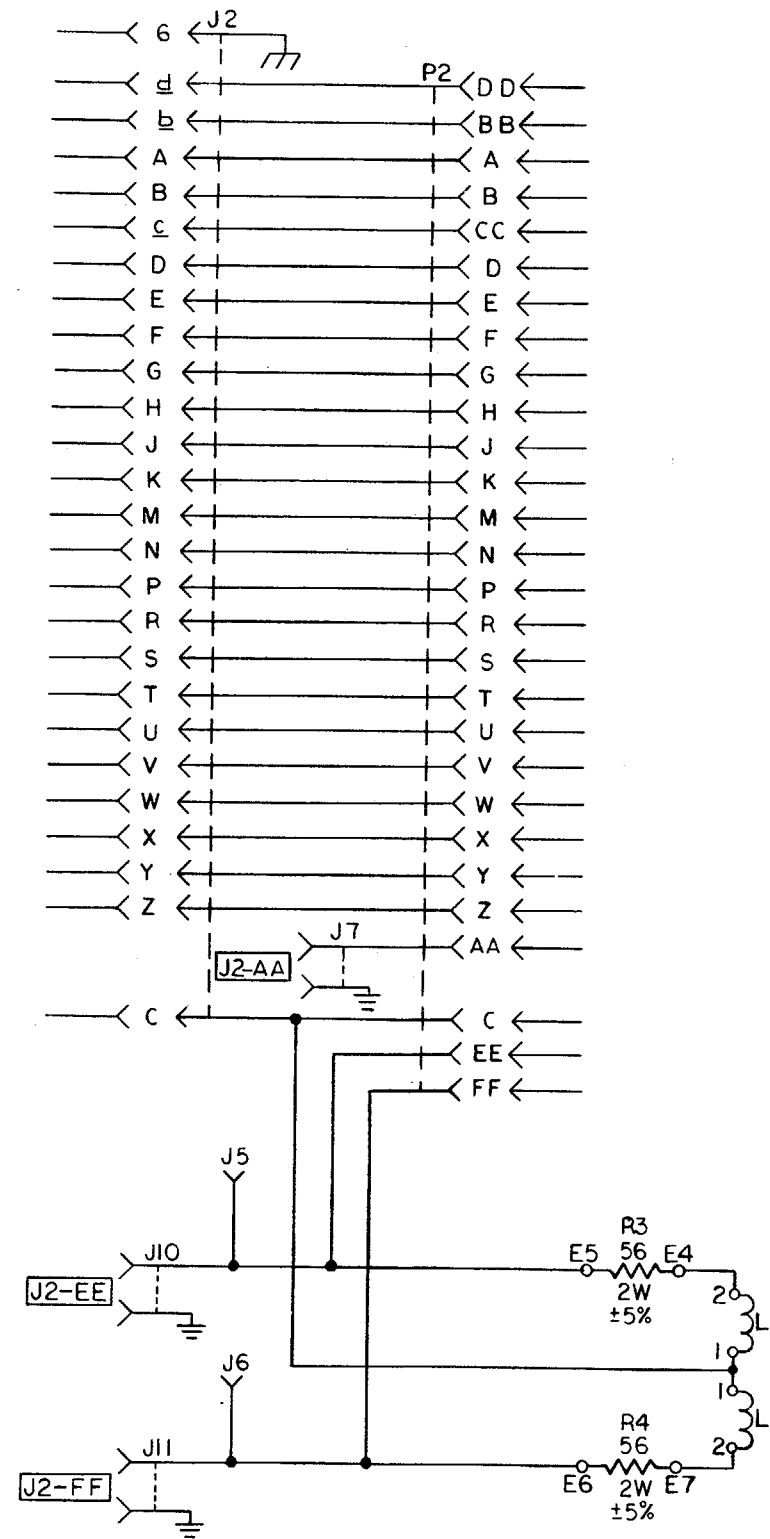

MS 604011

Figure 3-237.1. Unit adapter UA8-1061A 13233569*(AQ) (see note) (FG 3580)-schematic.

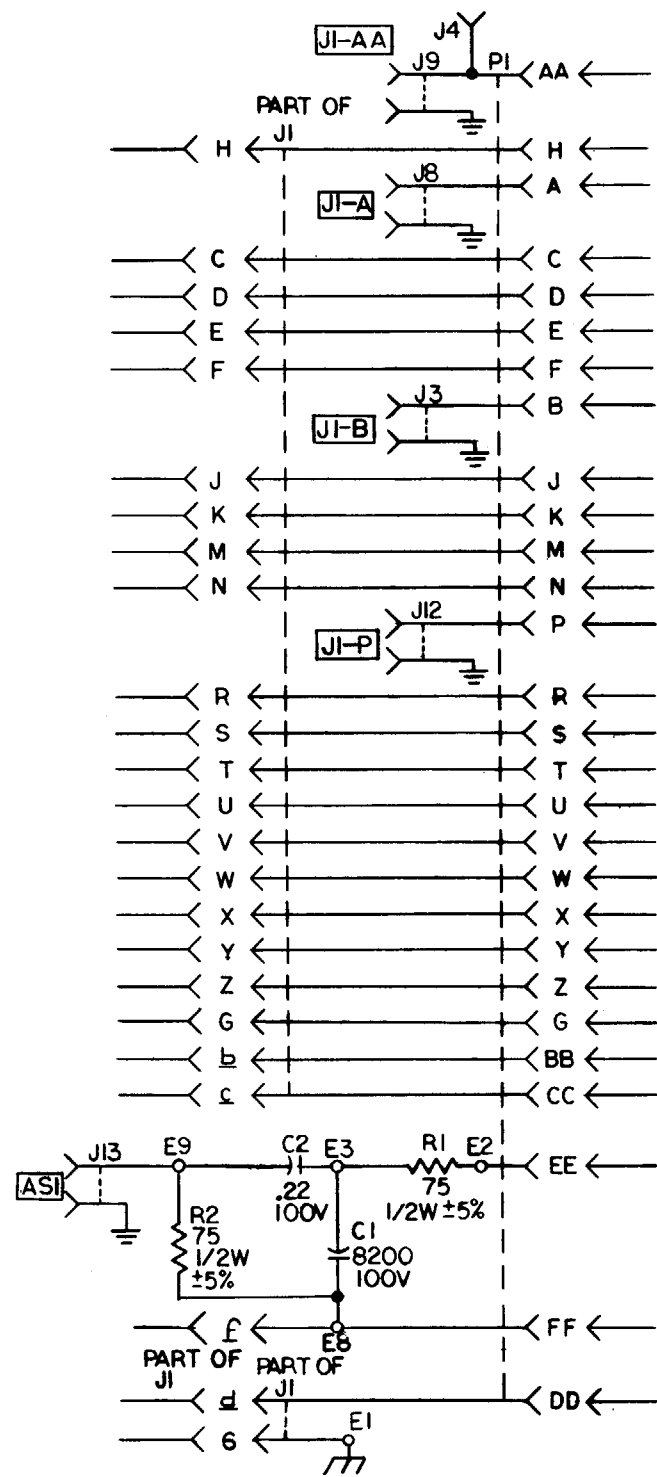

NOTE: REFER TO APPENDIX B FOR SERIAL NUMBER EFFECTIVITY.

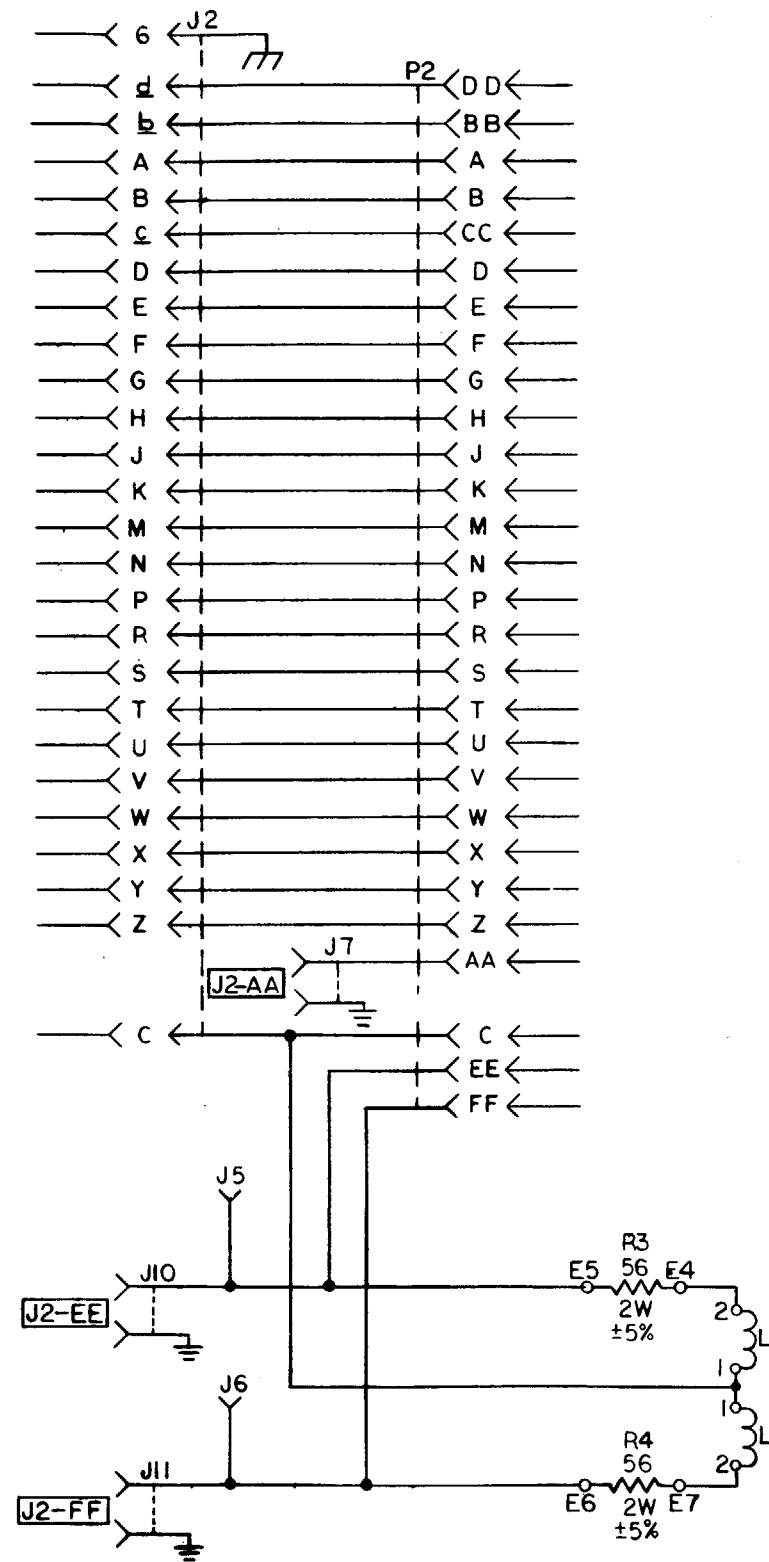

MI 70241A

Figure 3-238. Unit adapter UA8-1061 10671790*(AP (see note) (FG 3580)-schematic.

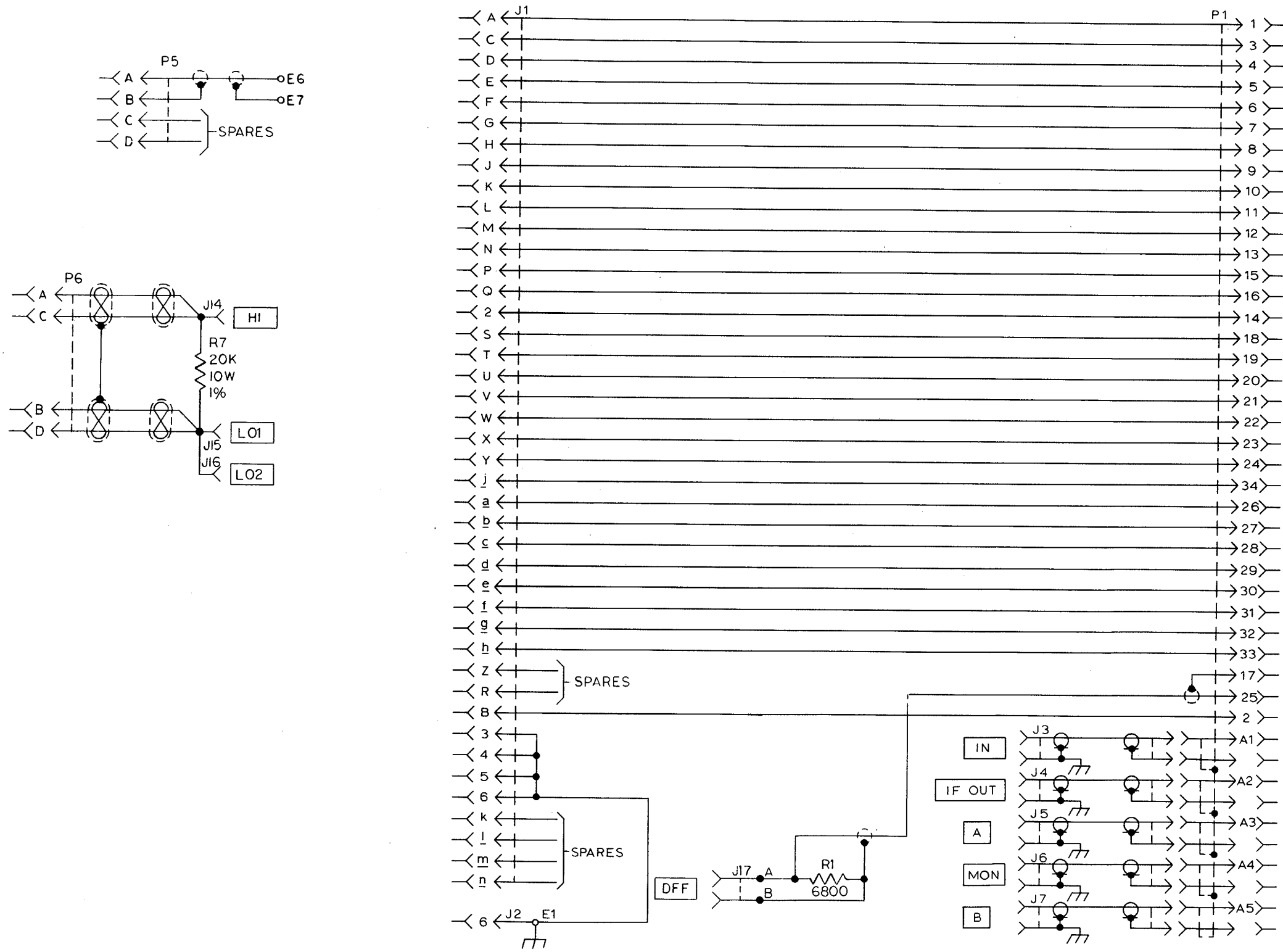

SEE SHEET 2

MI 70242

Figure 3-239. Unit adapter UA8-1062 10675083 (FG 2980)-schematic (sheet 1 of 2)

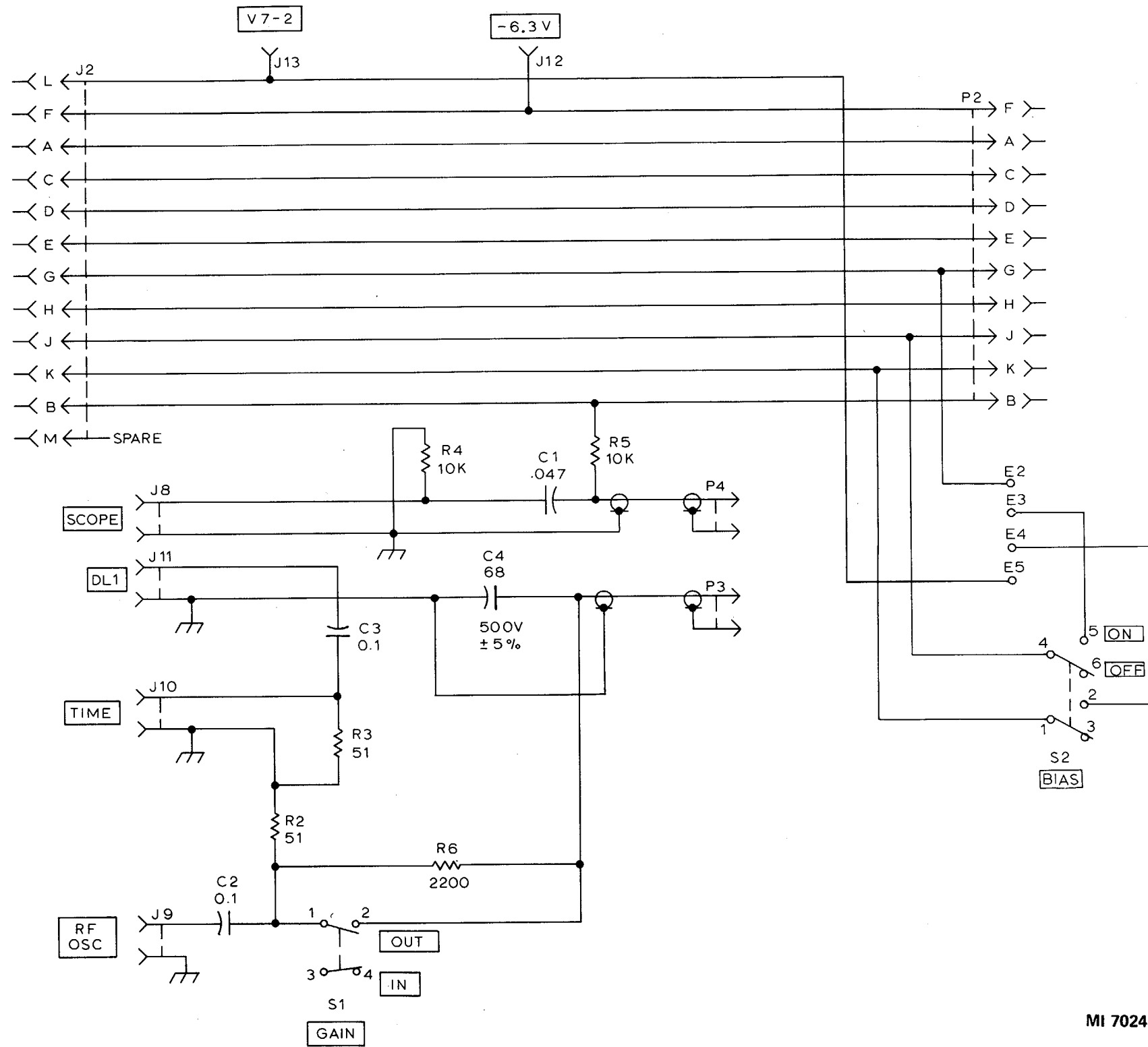

SEE SHEET 1

Figure 3-239. Unit adapter UA8-1062 10675083 (FG 2980)-schematic (sheet 2 of 2)

MI 70243

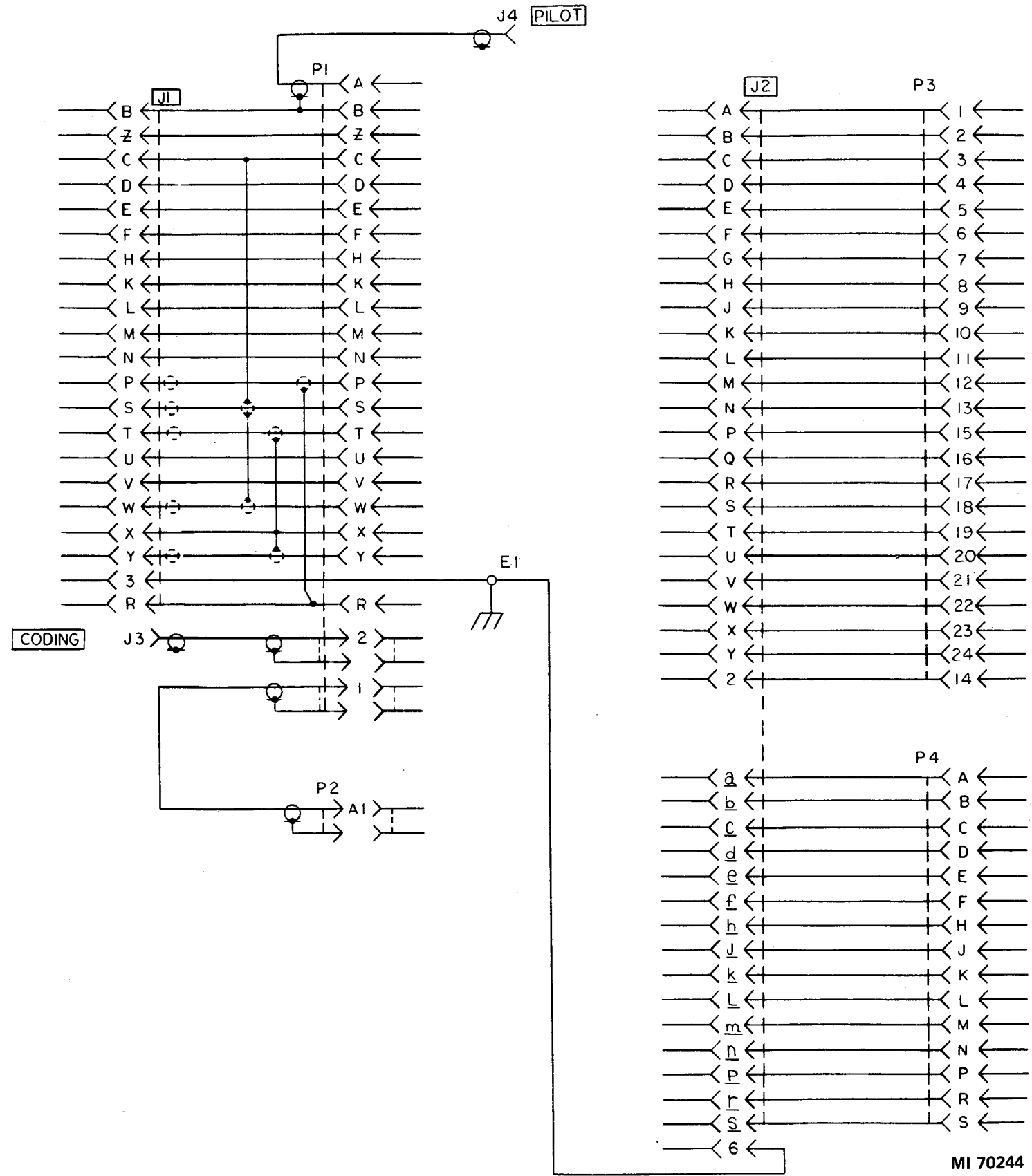
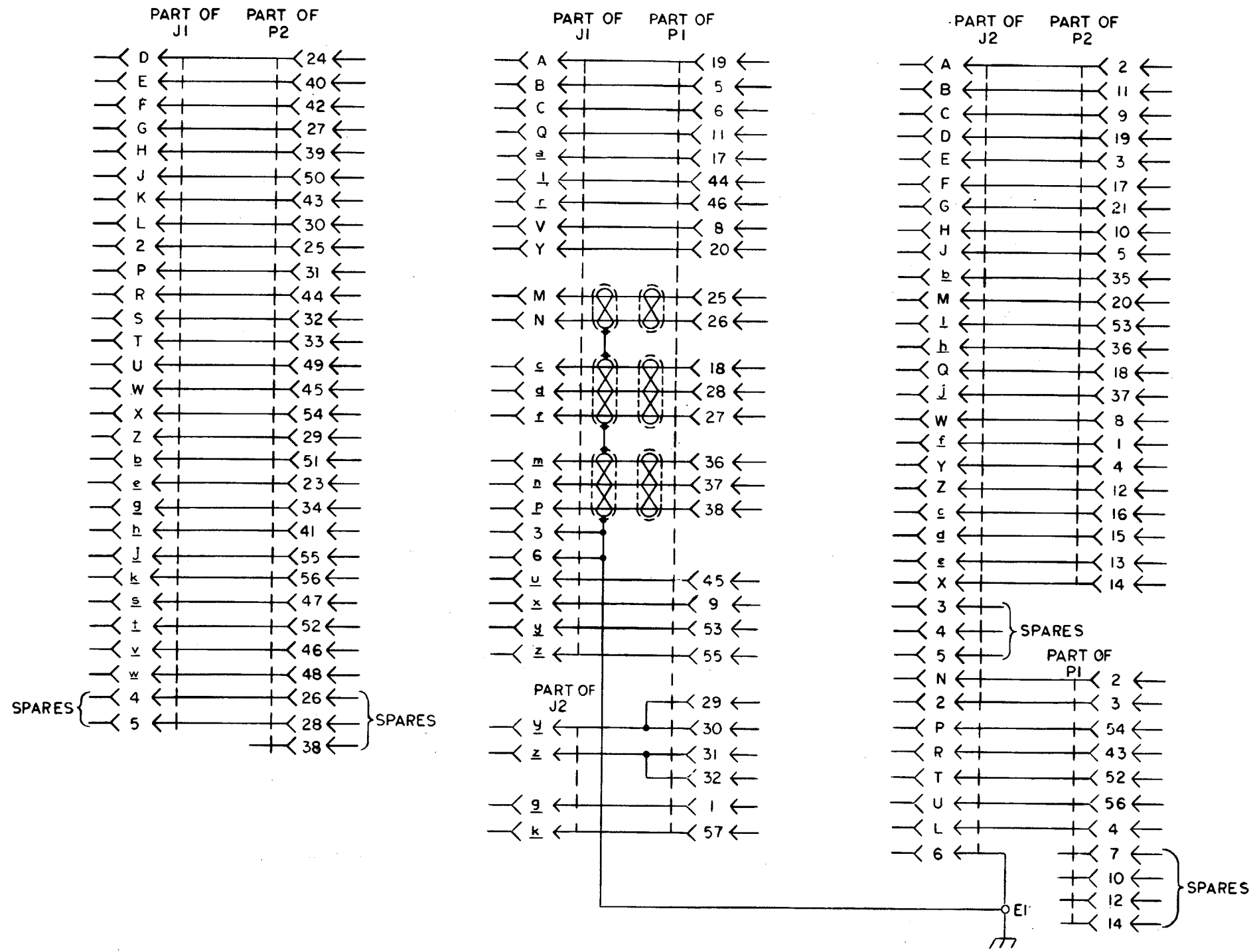
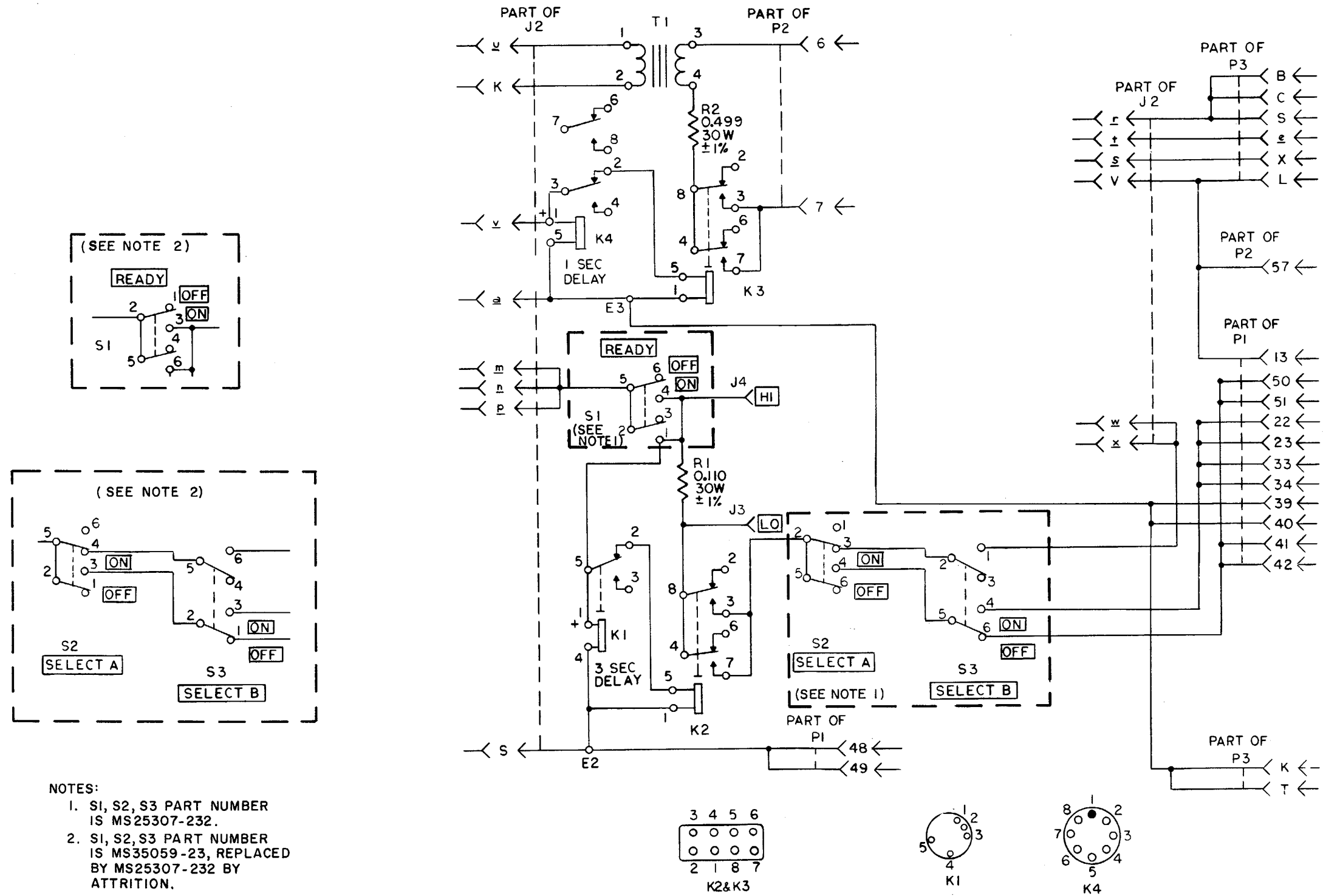

Figure 3-240. Unit adapter UA8-1064 10671791 (FG 3600)-schematic.



MI 70245

Figure 3-241. Unit adapter UA8-1065 10671822 (FG 3620)-schematic (sheet 1 of 2).



SEE SHEET 1

MI 70246A

Figure 3-241. Unit adapter UA8-1065 10671822 (FG 3620)-schematic (sheet 2 of 2).

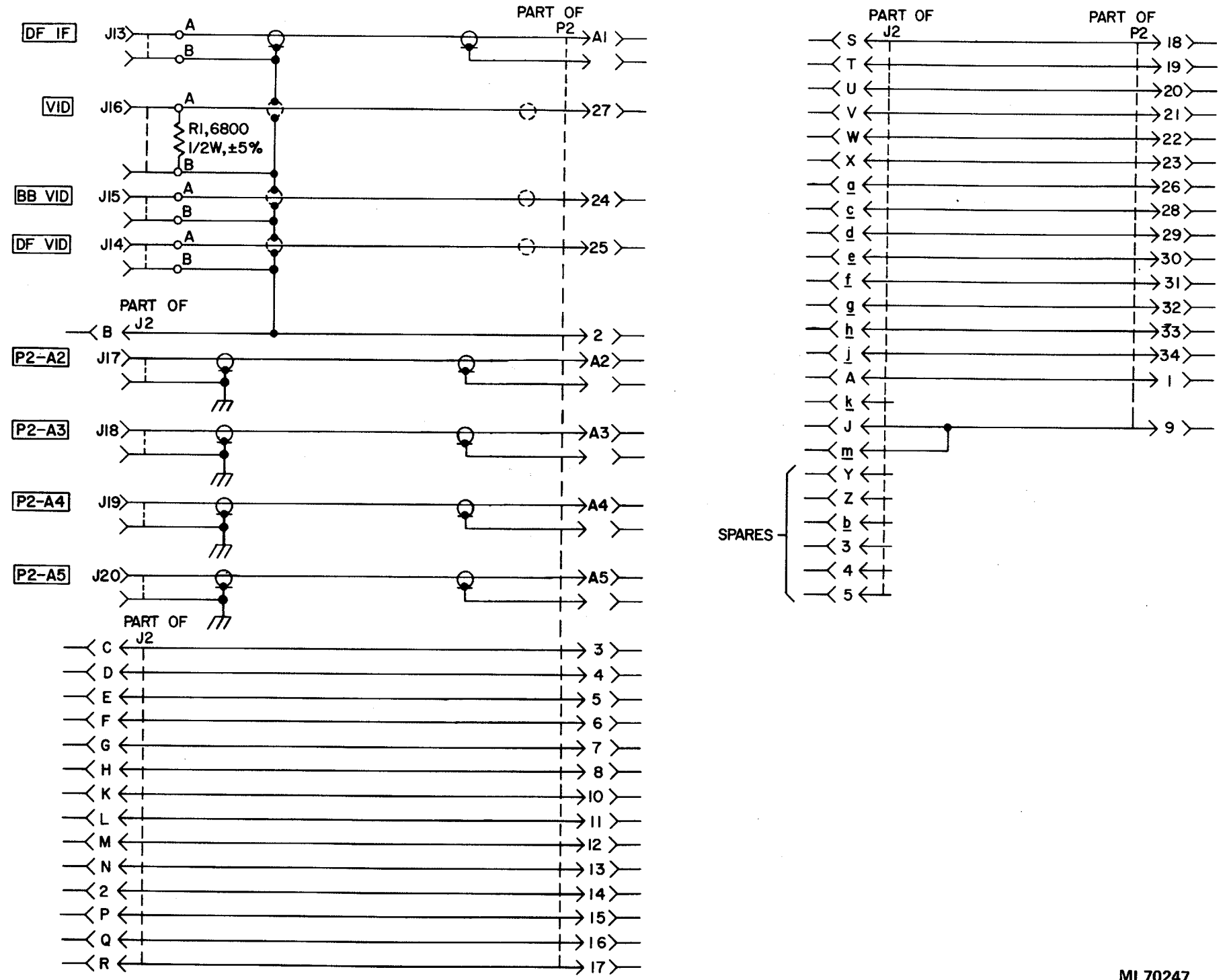

MI 70247

Figure 3-242. Unit adapter UA8-1066 10675321 (FG 3180)-schematic (sheet 1 of 2).

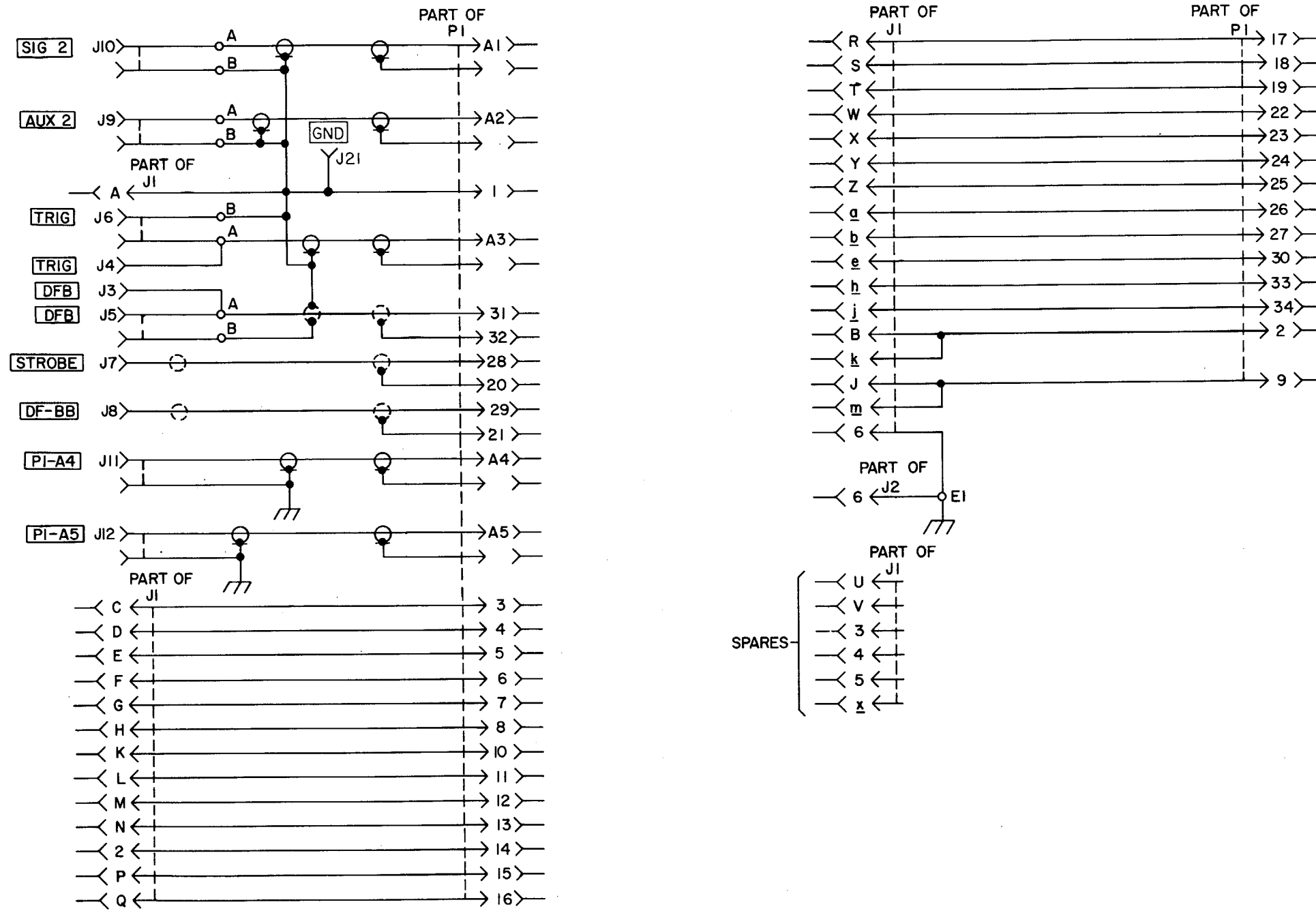

MI 70248

Figure 3-242. Unit adapter UA8-1066 10675321 (FG 3180)-schematic (sheet 2 of 2)

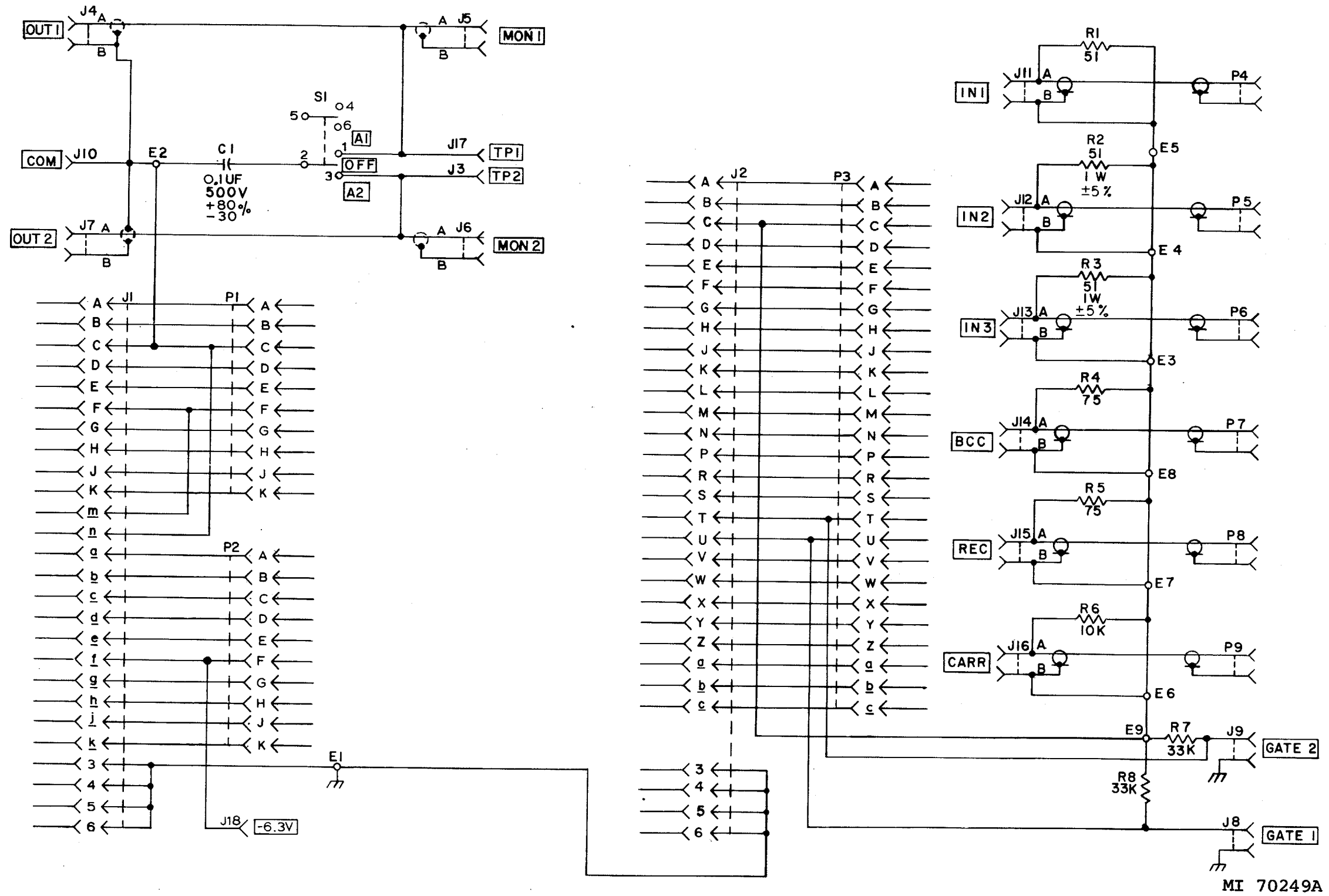
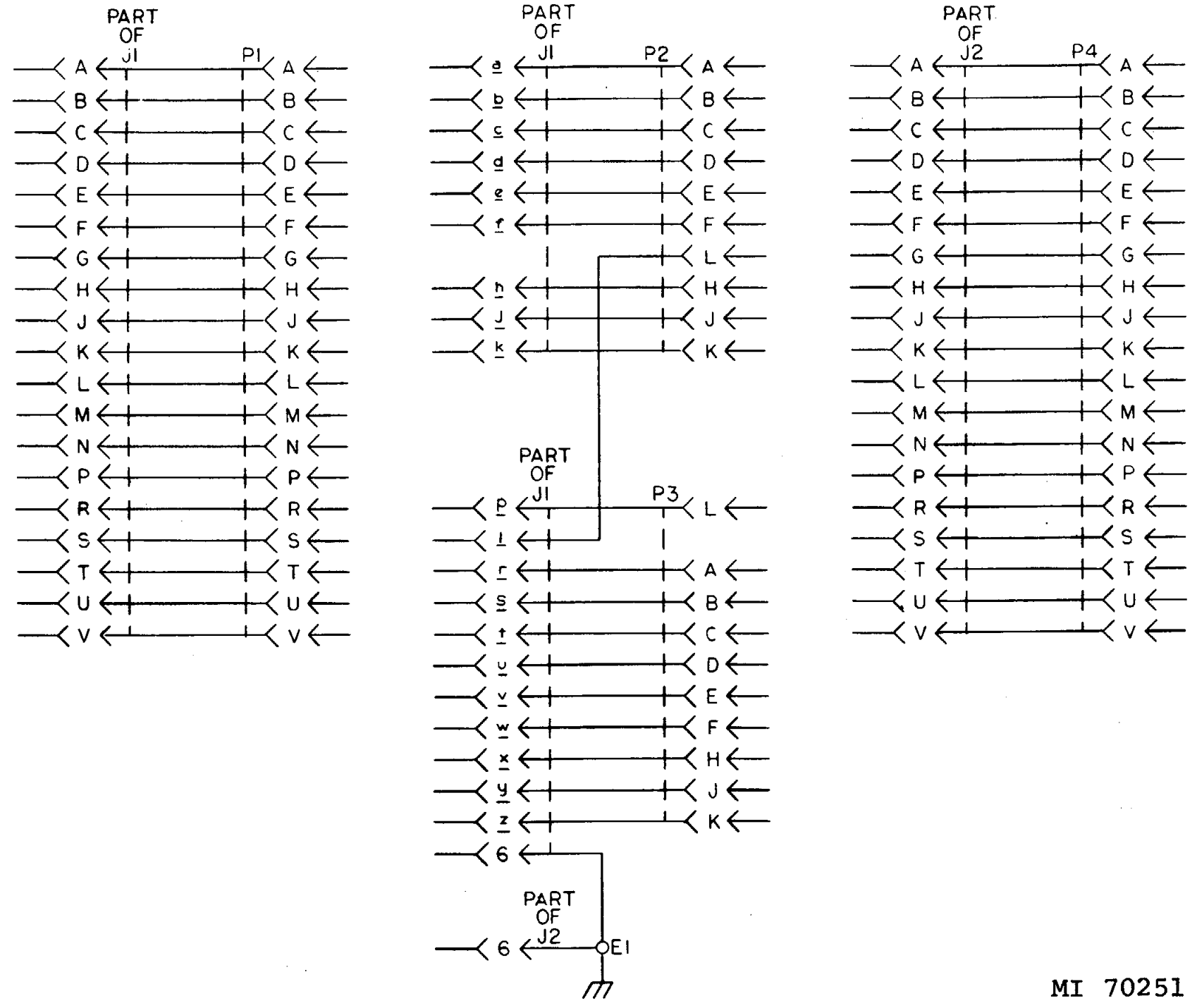

Figure 3-243. Unit adapter UA8-1067 10675329 (FG 3500)-schematic.



MI 70251

Figure 3-244. Unit adapter UA8-1069 10675245 (FG 3520)-schematic.

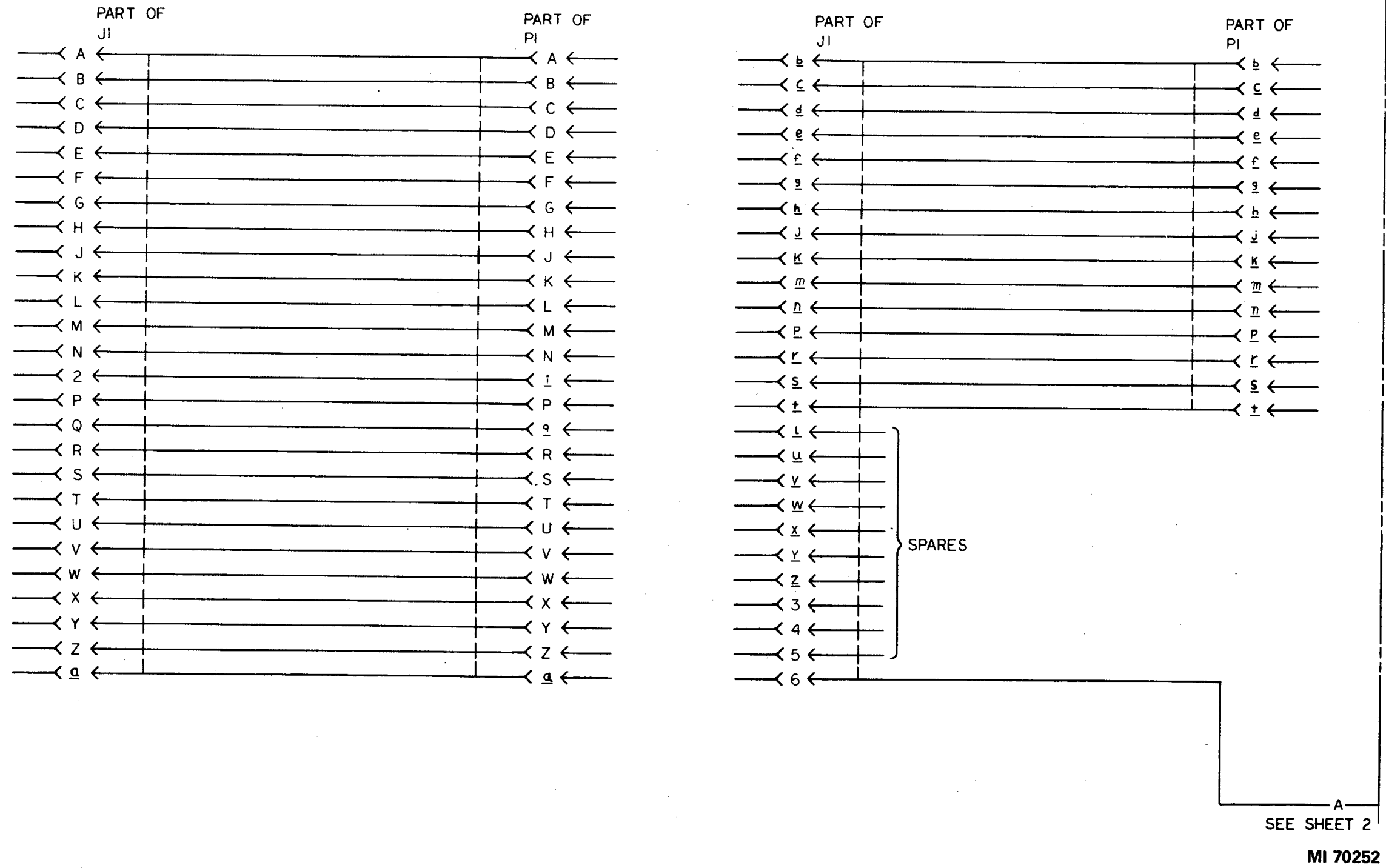
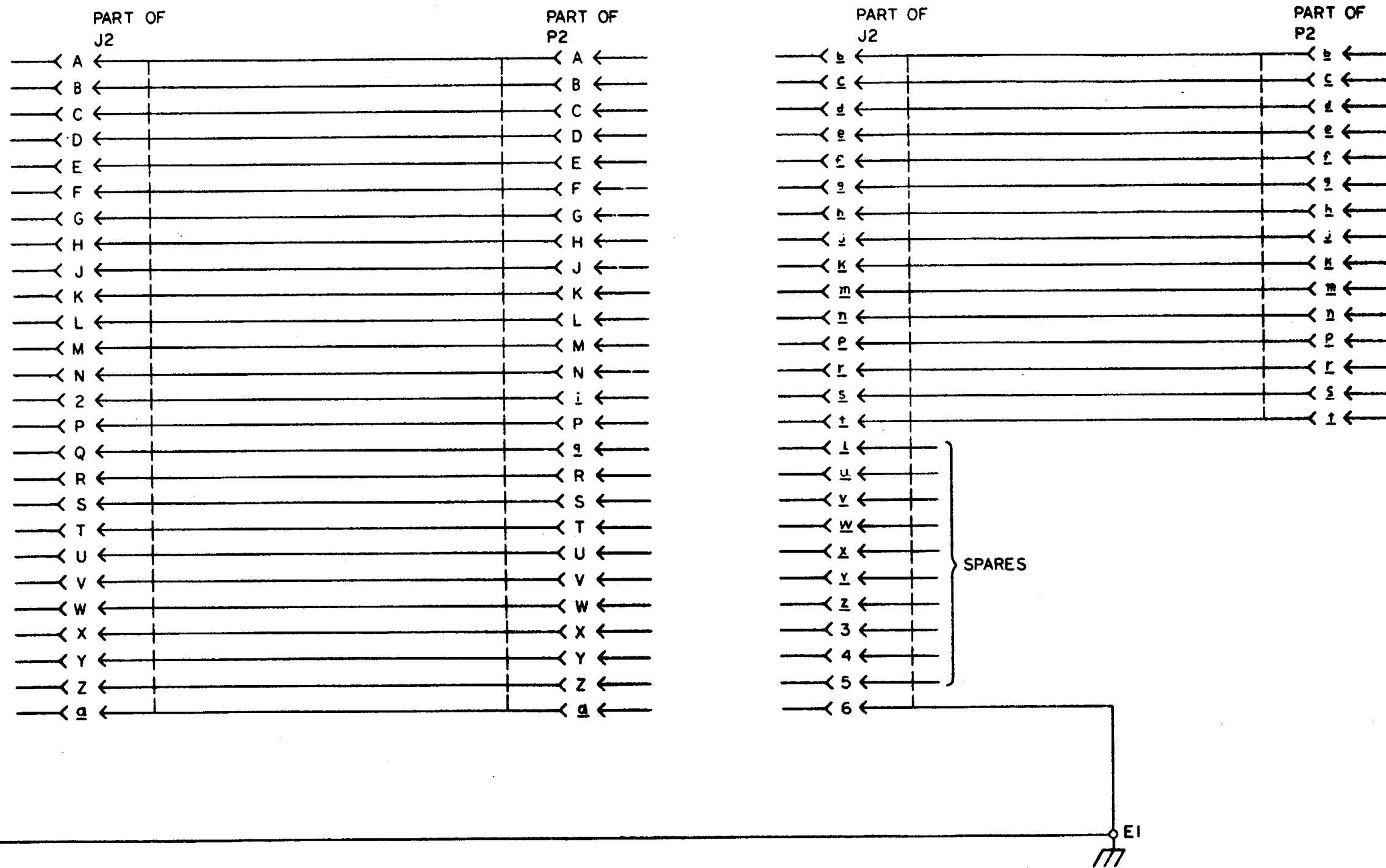

Figure 3-245. Unit adapter UA8-1070 10675330 (FG 3540)-schematic (sheet 1 of 2).



A
SEE SHEET 1

Figure 3-245. Unit adapter UA8-1070 10675330 (FG 3540)-schematic (sheet 2 of 2).

MS 309297

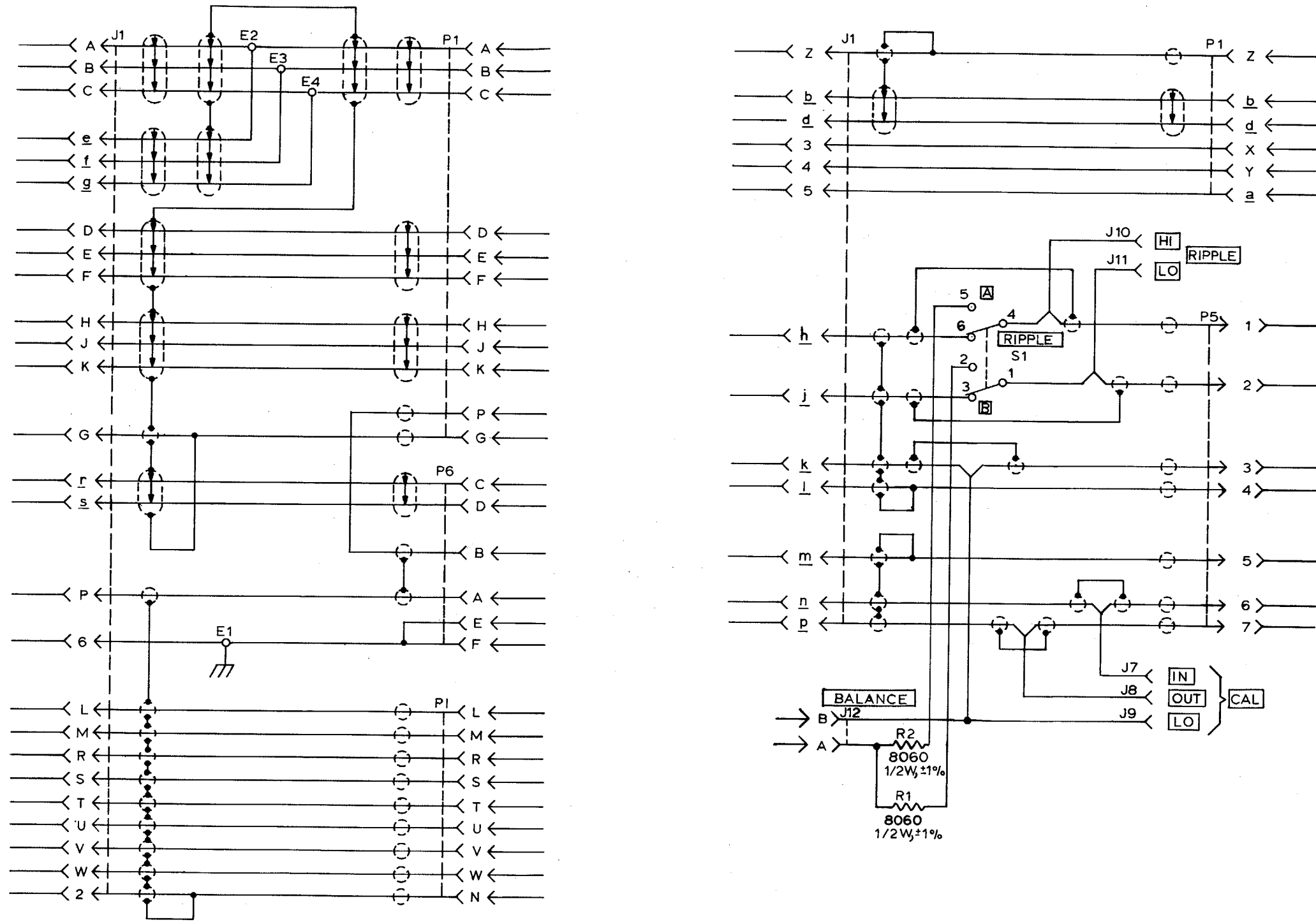

MS 309298

Figure 3-246. Unit adapter UA8-1075 11566014 (FG 4340)-schematic (sheet 1 of 2).

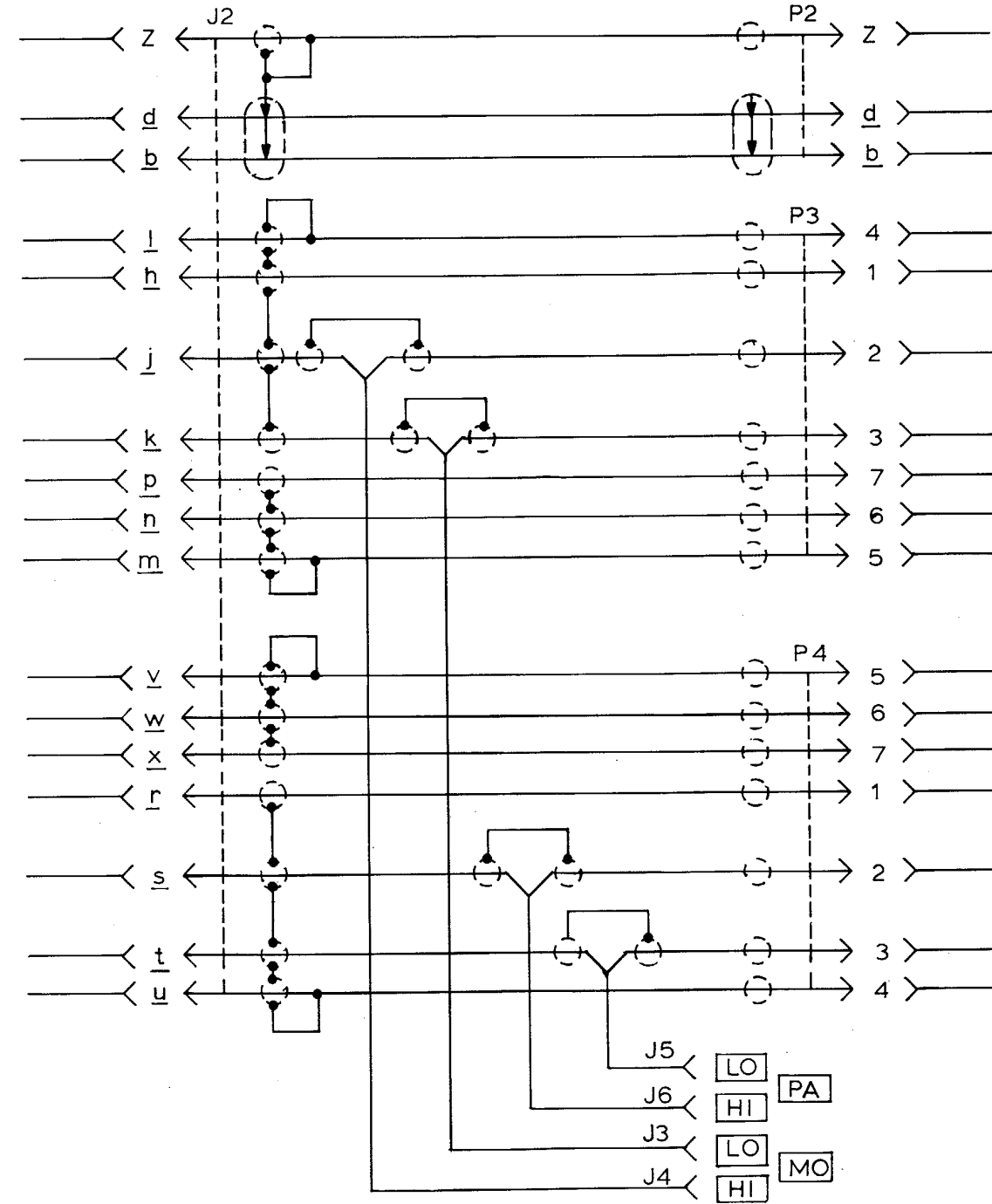
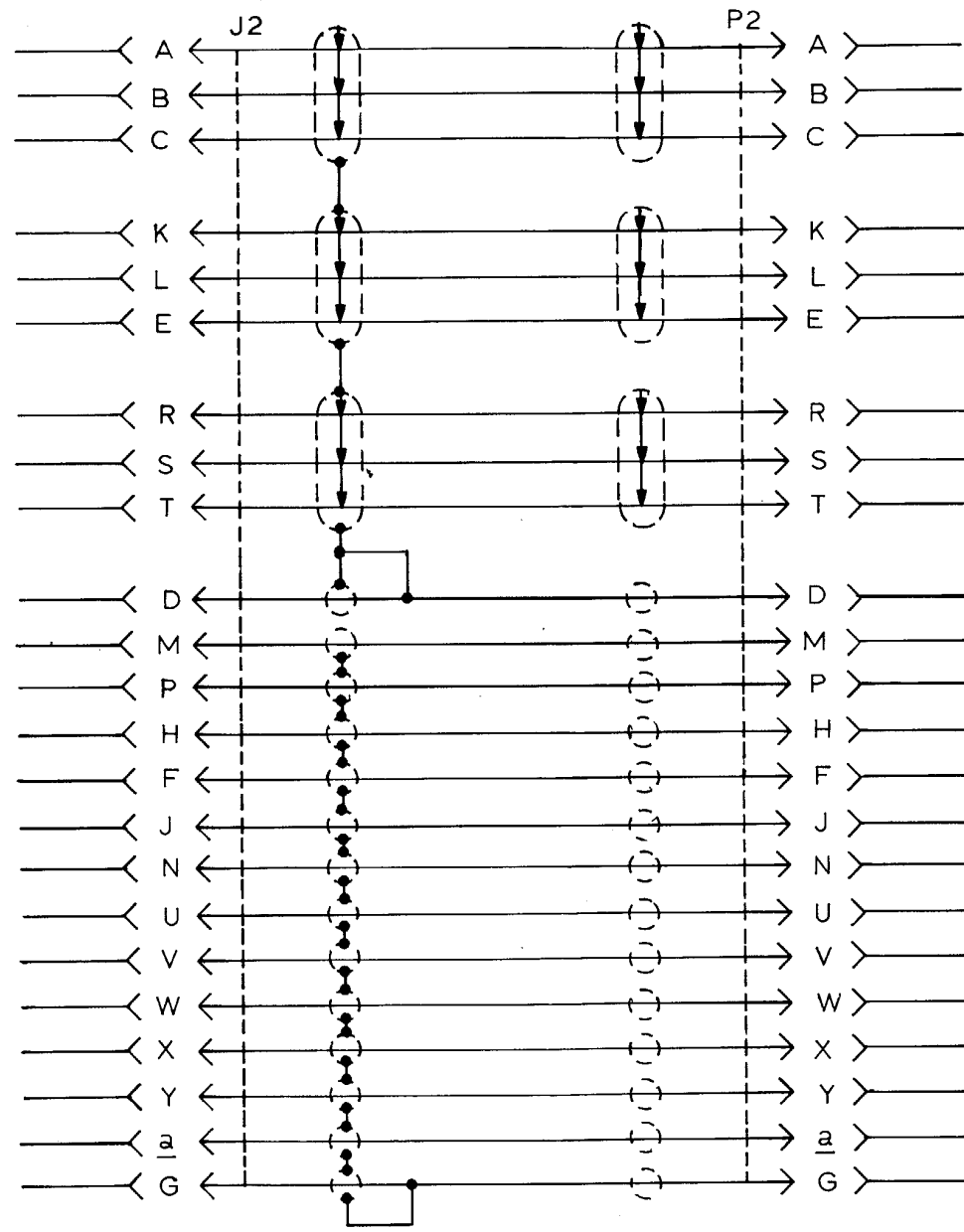
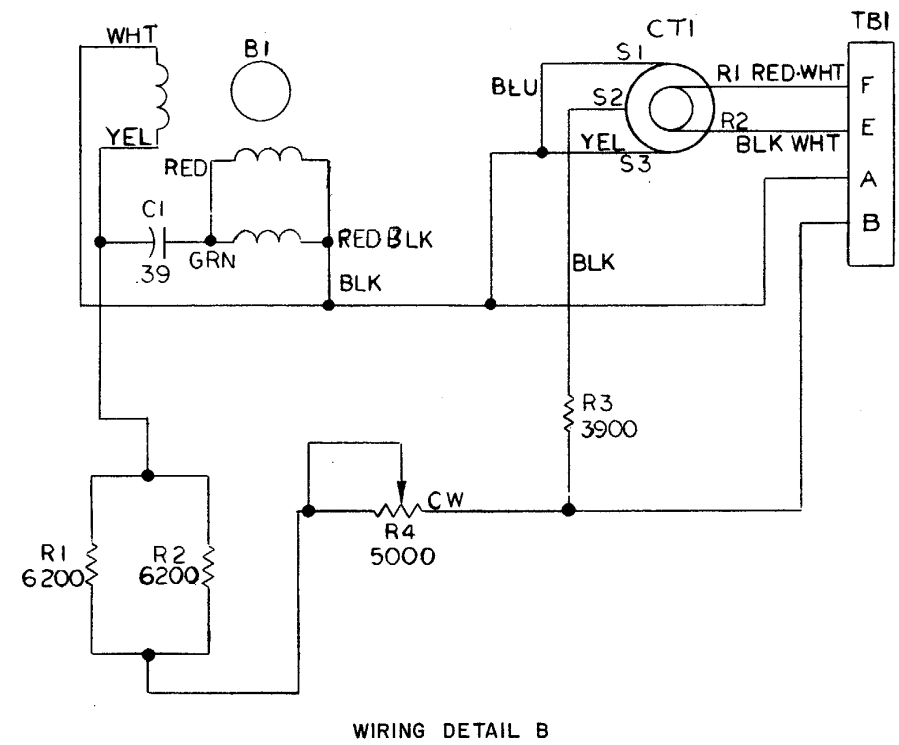
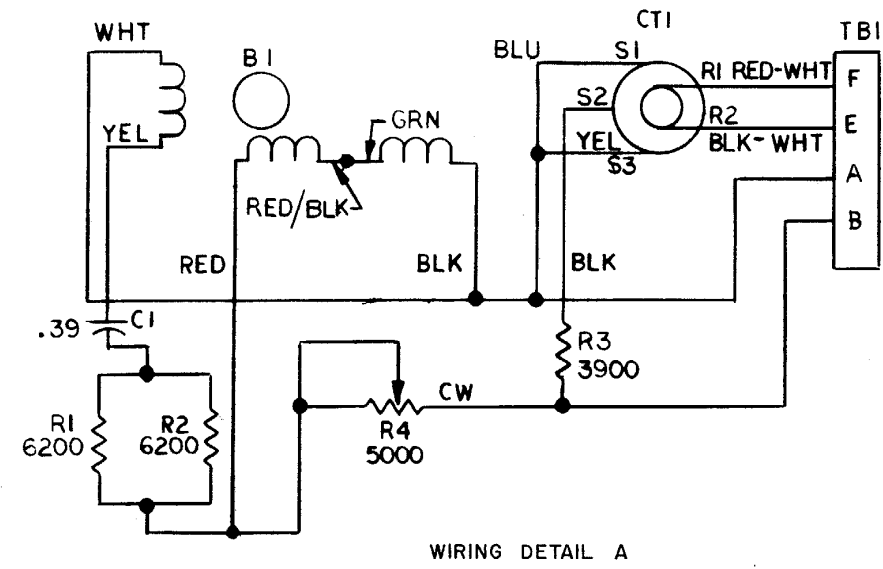

Figure 3-246. Unit adapter UA8-1075 11566014 (FG 4340)-schematic (sheet 2 of 2).

MS 309299



MI 70254A

Figure 3-247. Antenna rotation simulator 10046996 (FG 2550)-schematic.

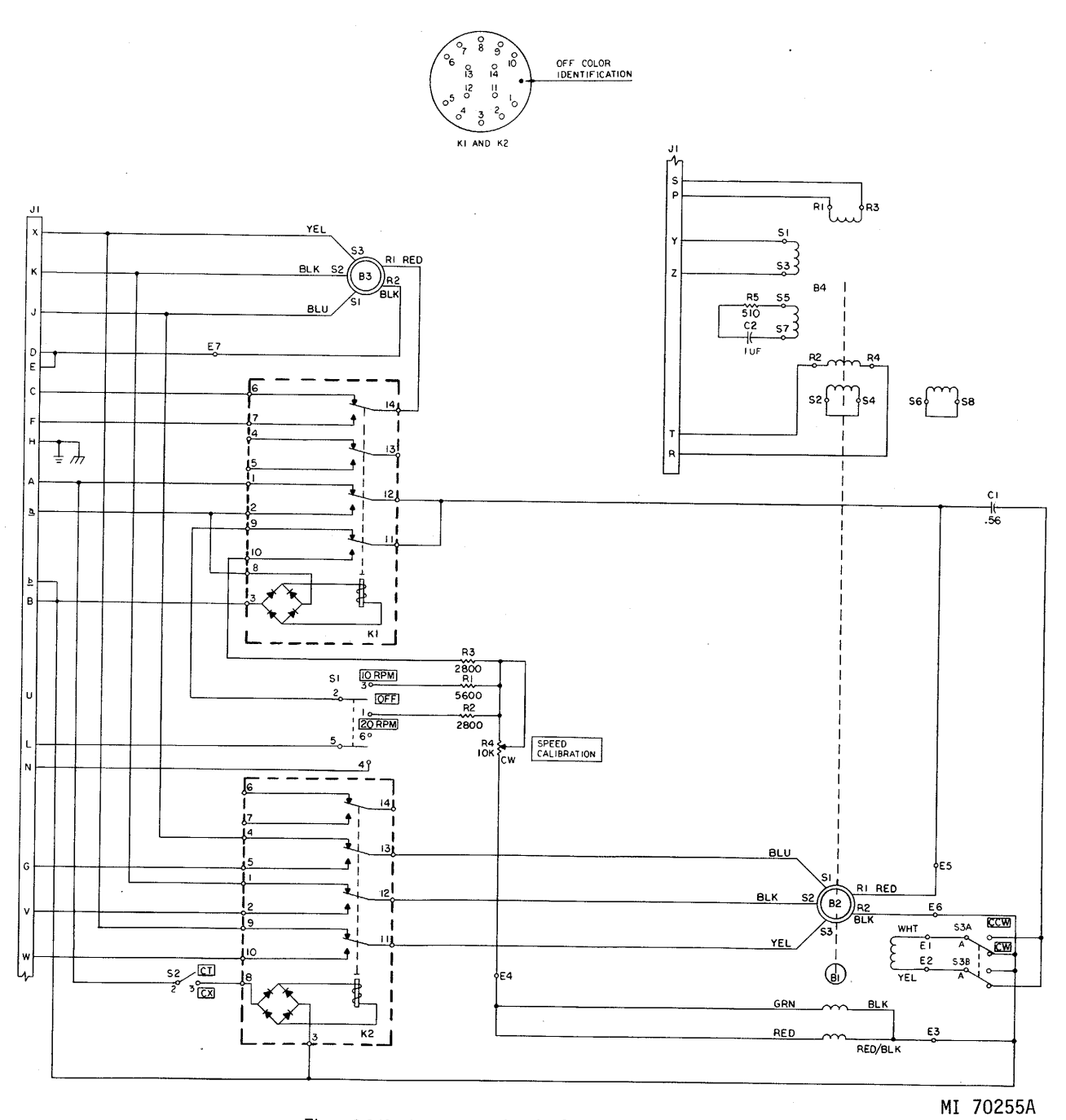
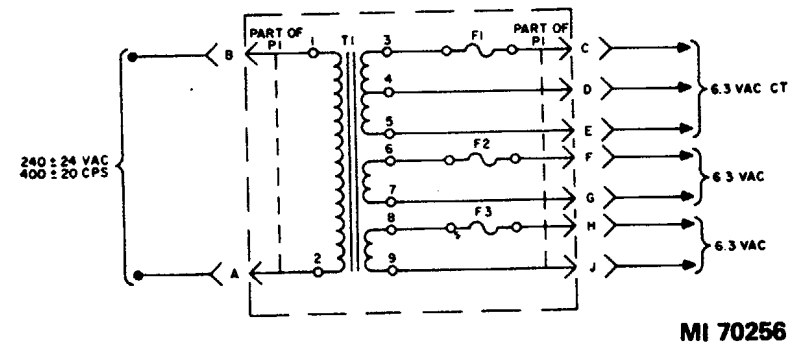
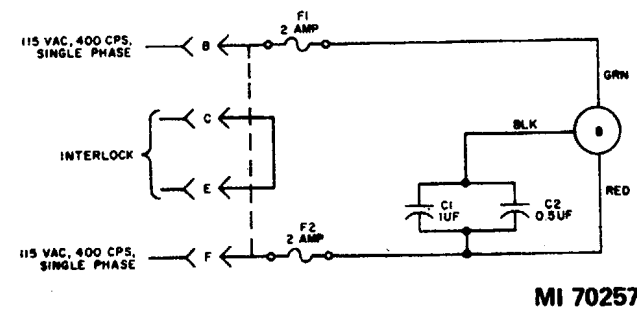

Figure 3-248. Antenna rotation simulator 10108793 (FG 2725)-schematic.



MI 70256

Figure 3-249. Auxiliary power transformer 10066907 (FG 2600) - schematic.



MI 70257

Figure 3-250. Blower assembly 9187123 (FG 2325) - schematic.

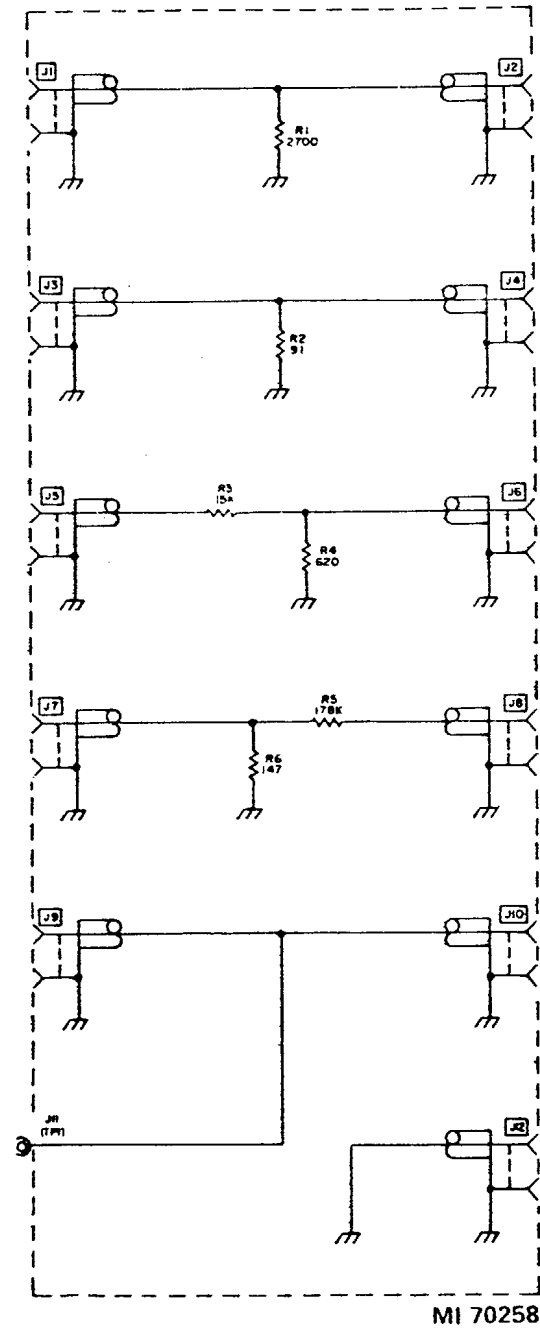

MI 70258

Figure 3-251. Coaxial termination box 9188871 (FG 0100) - schematic.

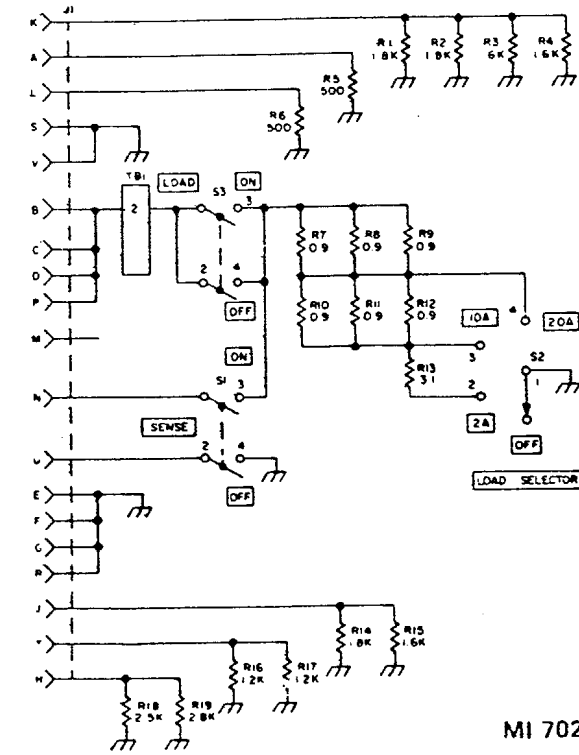

MI 70260

Figure 3-252. Low-voltage dummy load 10107545 (FG 1320) - schematic.

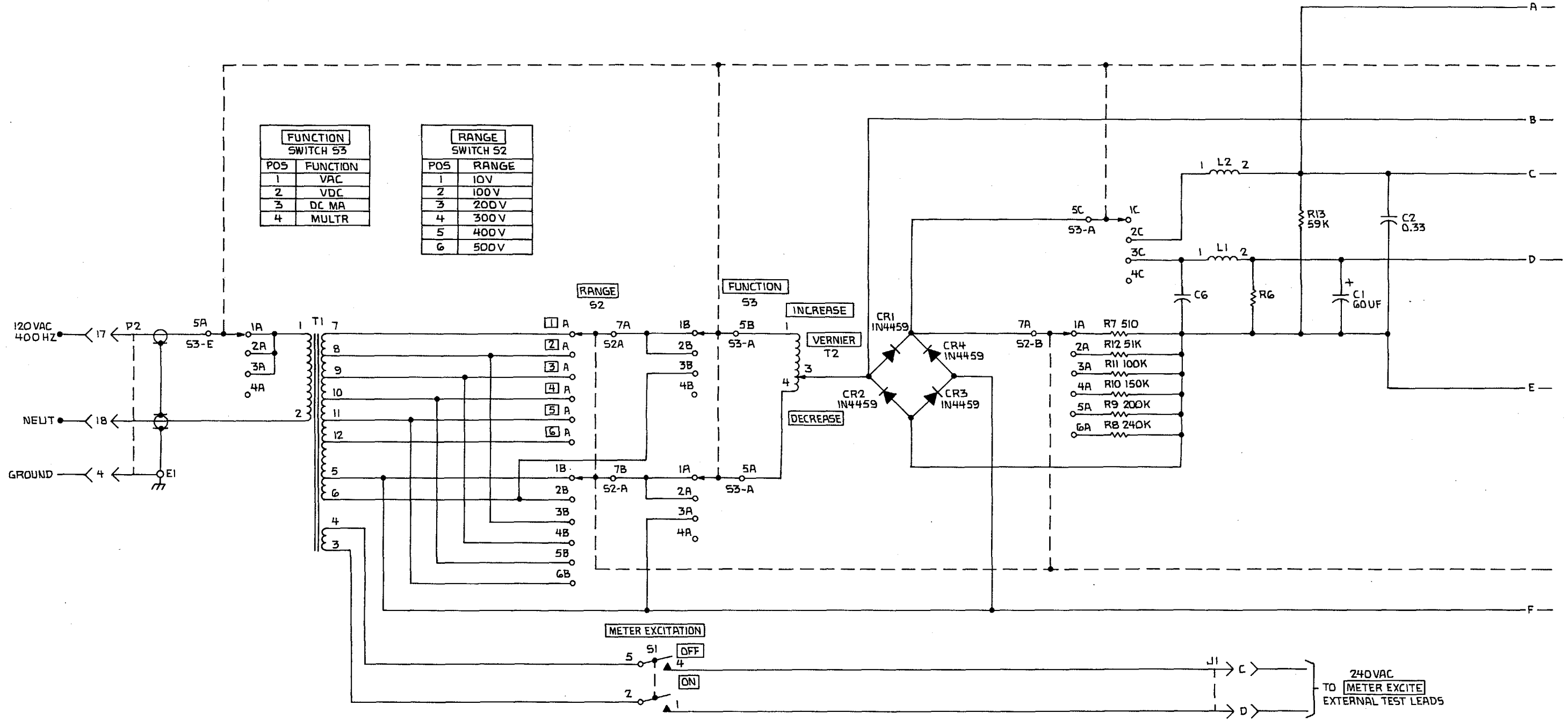

Figure 3-253. Ac-dc power source 10178633 (P/O FG 2900) - schematic (sheet 1 of 2).

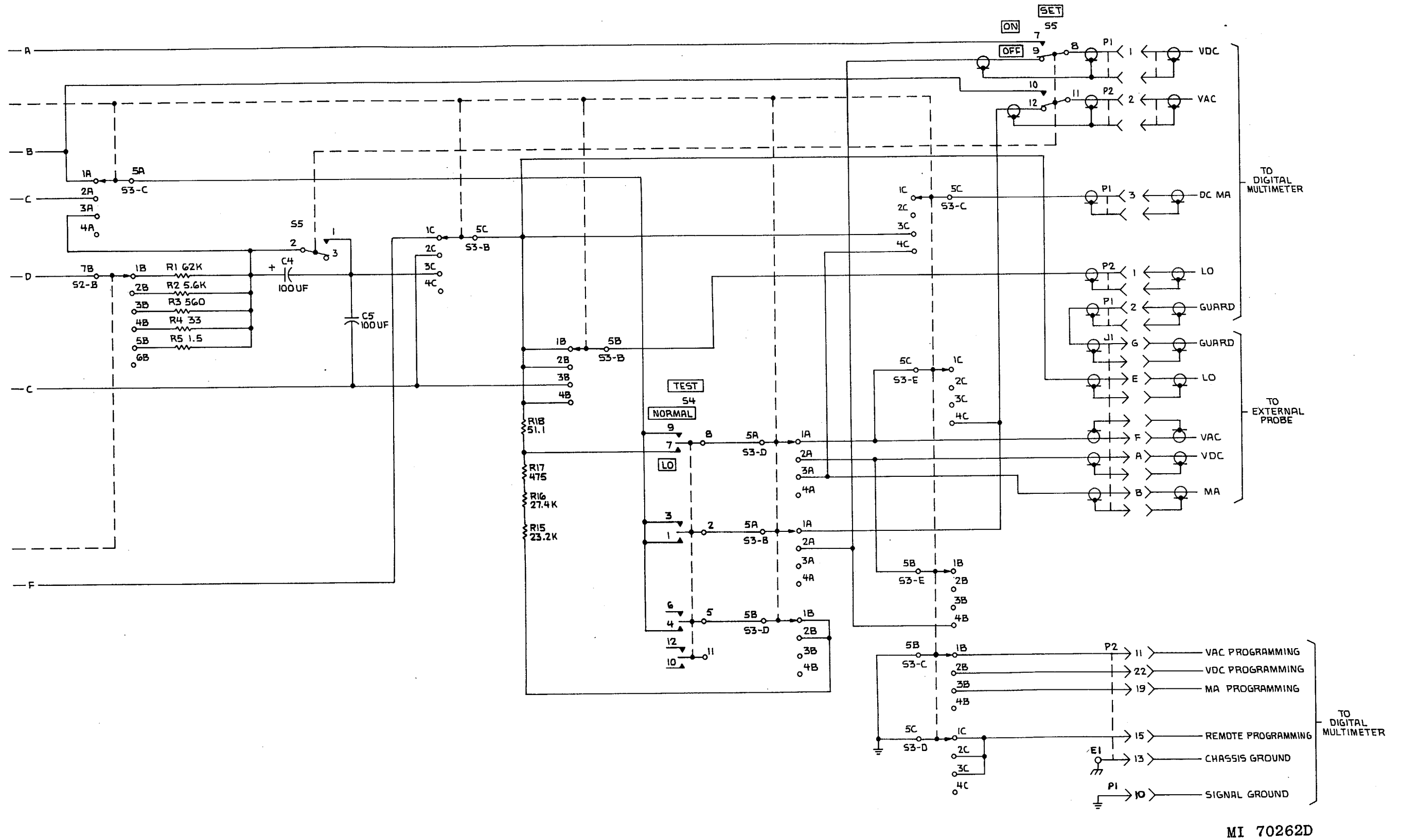

Figure 3-253. Ac-dc power source 10178633 (P/O FG 2900) - schematic (sheet 2 of 2).

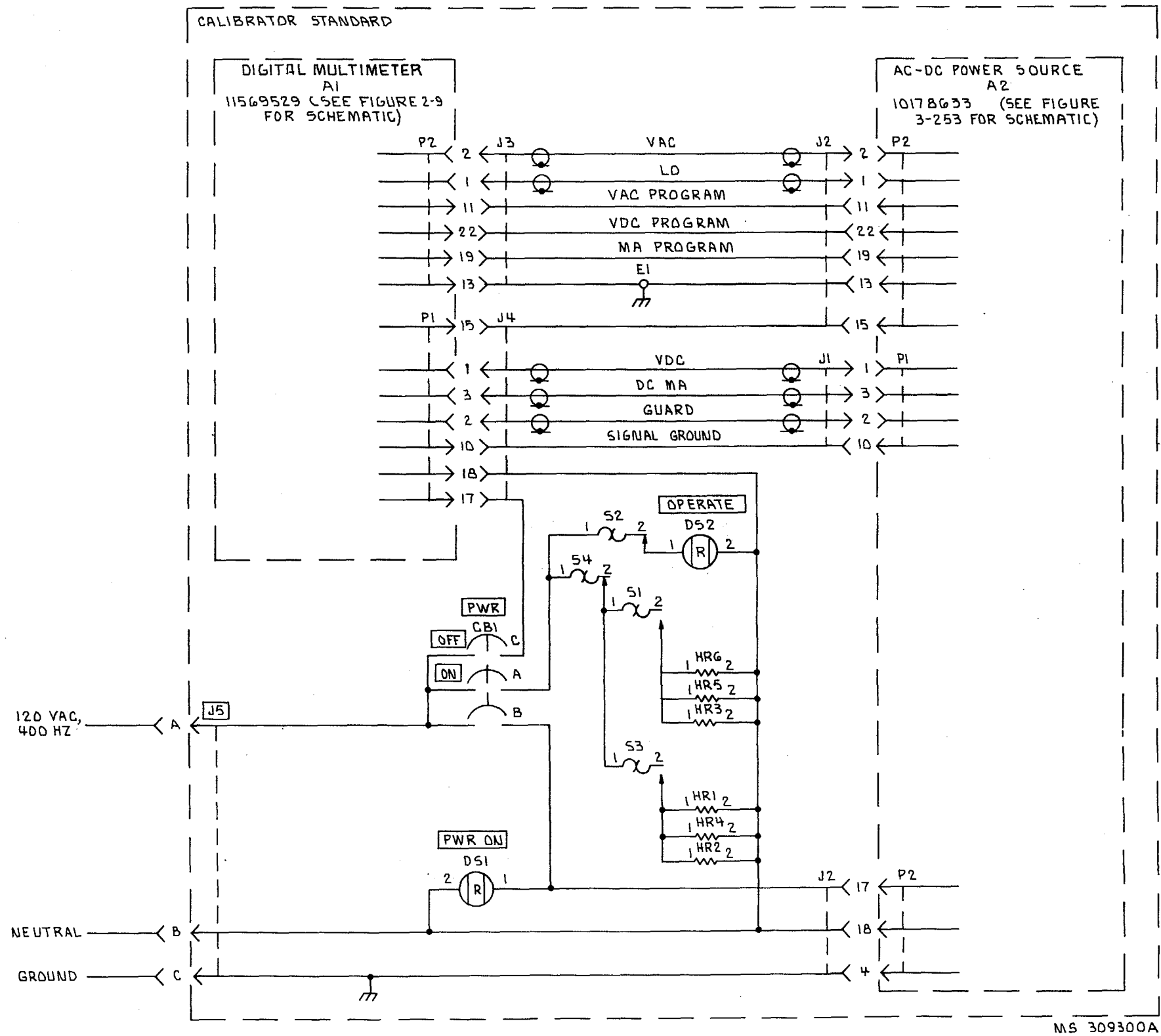

Figure 3-254. Calibrator standard 10178692 (FG 2900) - schematic.

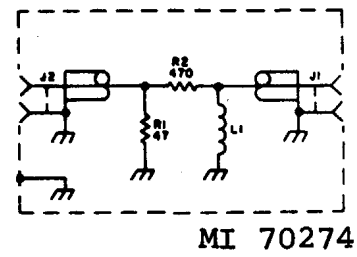

Figure 3-255. Mixer simulator 10104984 (FG 2650) - schematic.

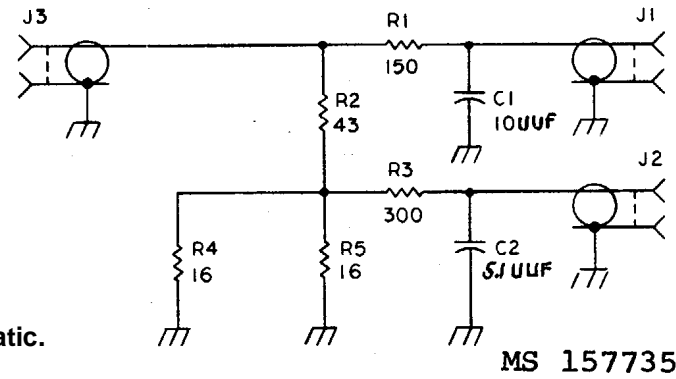
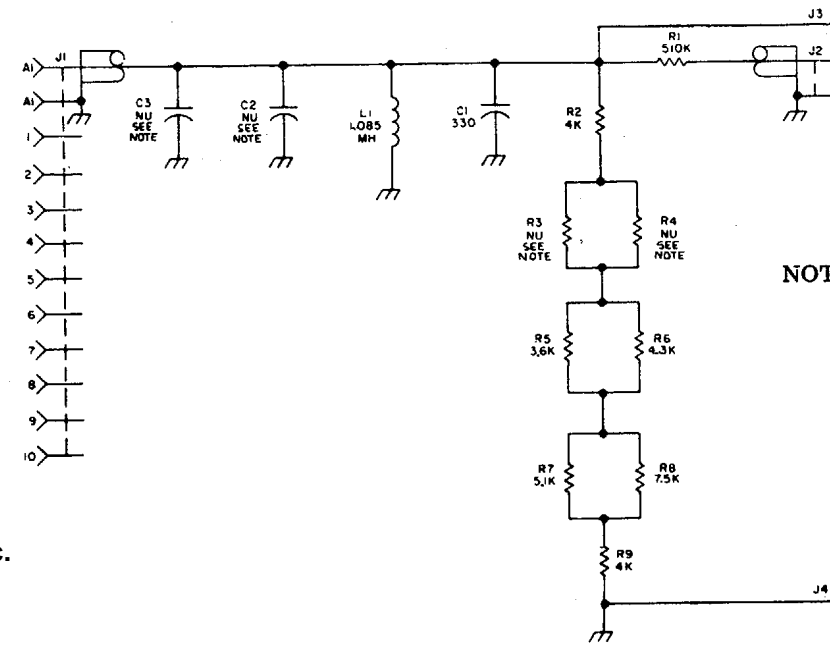

Figure 3-256. Network crystal simulator 10107073 (FG 0100) - schematic.



- NOTES 1. REFER TO APPENDIX B FOR SERIAL NUMBER EFFECTIVITY.
2. THE SPECIFIC VALUES OF THE NOMINAL PIECE PARTS ARE LISTED IN THE APPARATUS LIST OF THIS UNIT.

Figure 3-257. Phase modulator simulator 10109986 *(AB) (see note 1) (FG 2800) - schematic.

Figure 3-258. Deleted.

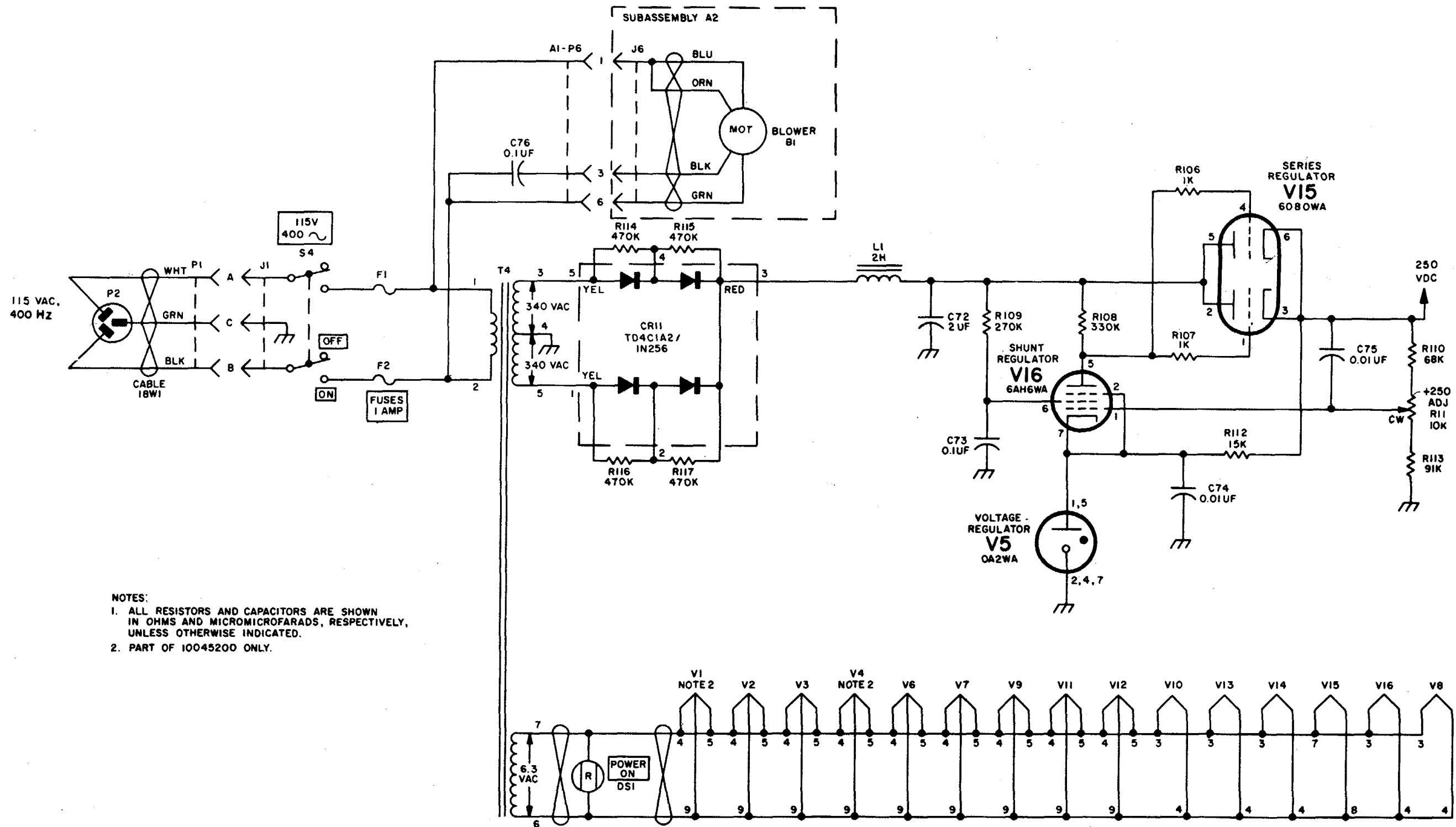

NOTES:
 1. ALL RESISTORS AND CAPACITORS ARE SHOWN IN OHMS AND MICROMICROFARADS, RESPECTIVELY, UNLESS OTHERWISE INDICATED.
 2. PART OF 10045200 ONLY.

MI 70276

Figure 3-259. Radar target simulator 10045265 (FG 2360) - schematic (sheet 1 of 3).

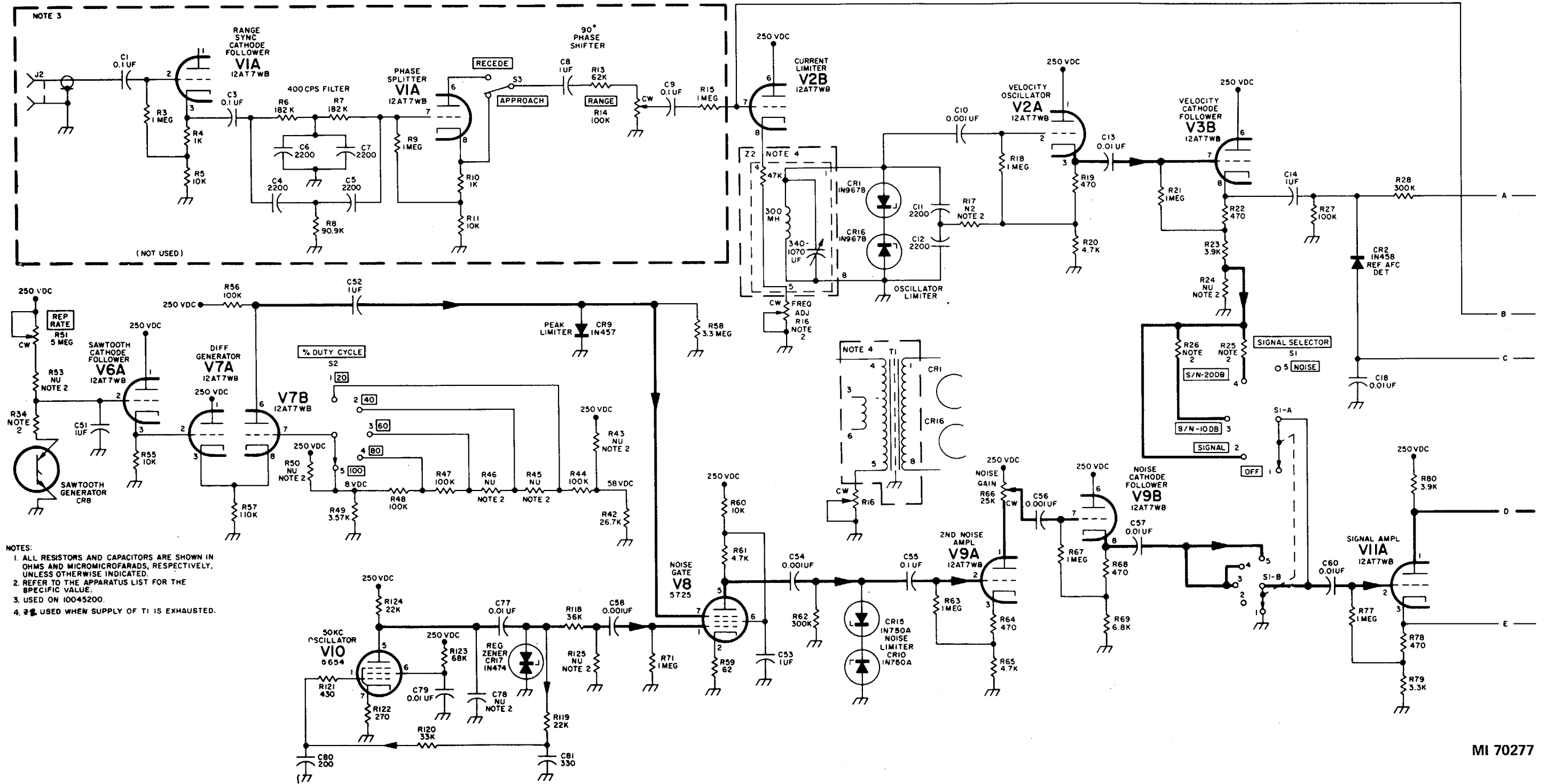

Figure 3-259. Radar target simulator 10045265 (FG 2360) - schematic (sheet 2 of 3).

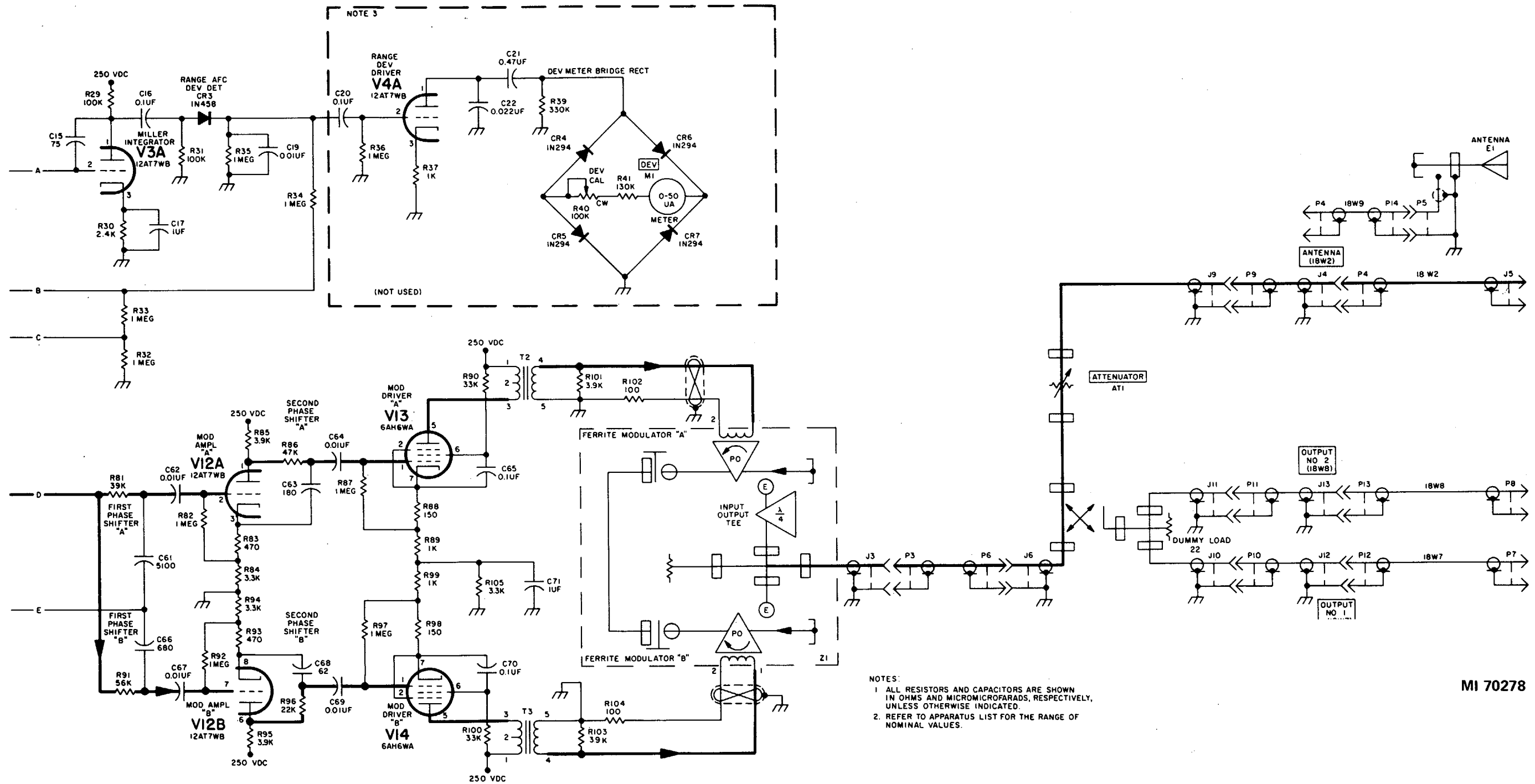

Figure 3-259. Radar target simulator 10045265 (FG 2360) - schematic (sheet 3 of 3).

MI 70278

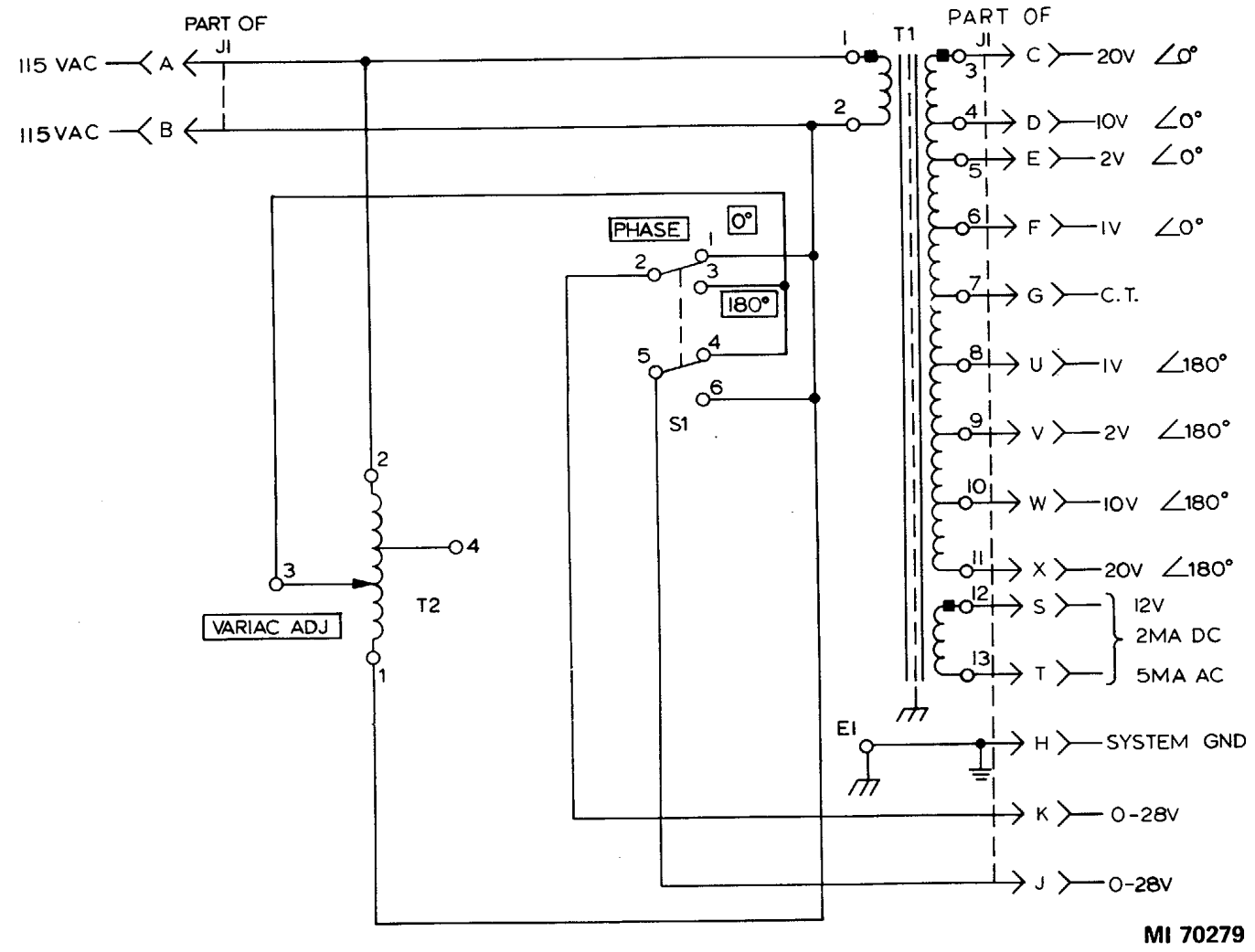

Figure 3-260. Transformer test set 10674766 (FG 2880) - schematic.

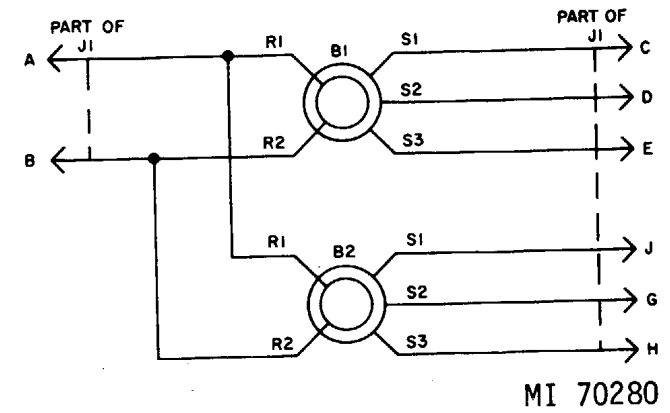
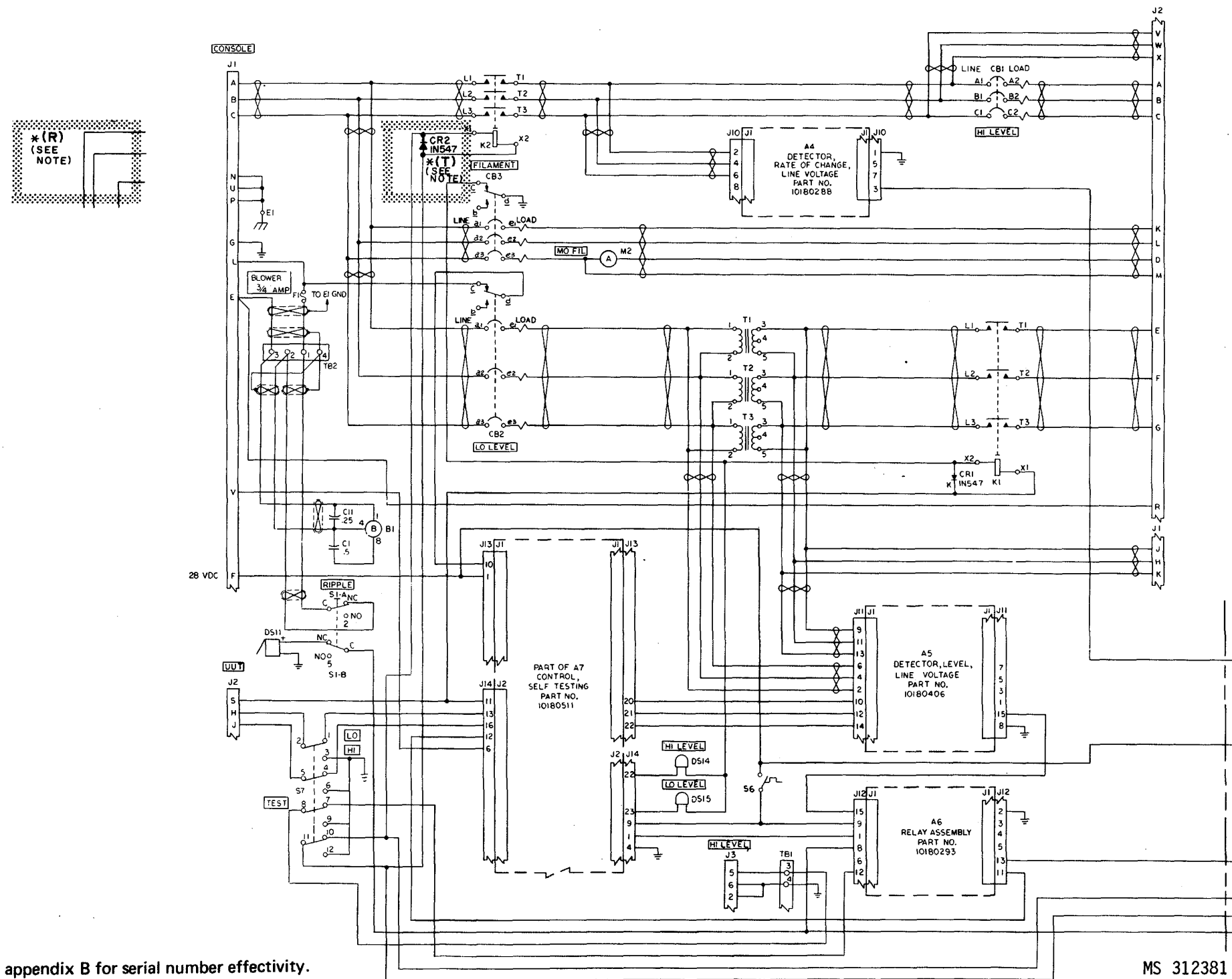

Figure 3-261. Transmitter synchro calibrator assembly 10110818 (FG 0100) - schematic.

Section IV. POWER SUPPLY TEST SET 10180927 (FG 1300)



Note. Refer to appendix B for serial number effectivity.

MS 312381

Figure 3-262. Distribution box - dummy load 11566717 *(T), 10676830 *(R) (see note) (FG 1340) - schematic (sheet 1 of 3).

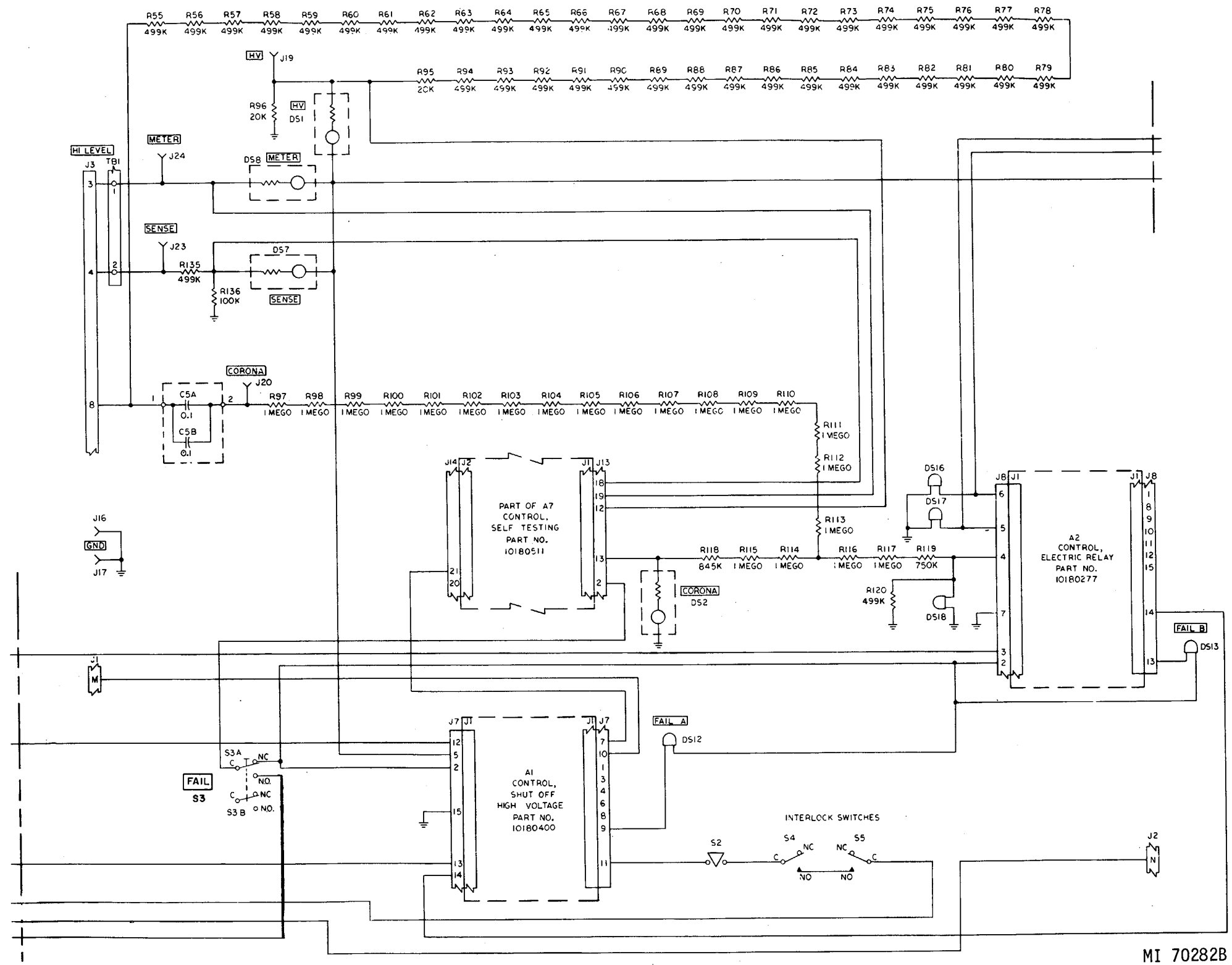

Note: Refer to appendix B for serial number effectivity.

Figure 3-262. Distribution box - dummy load 11566717 *(T), 10676830 *(R) (see note) (FG 1340) - schematic (sheet 2 of 3).

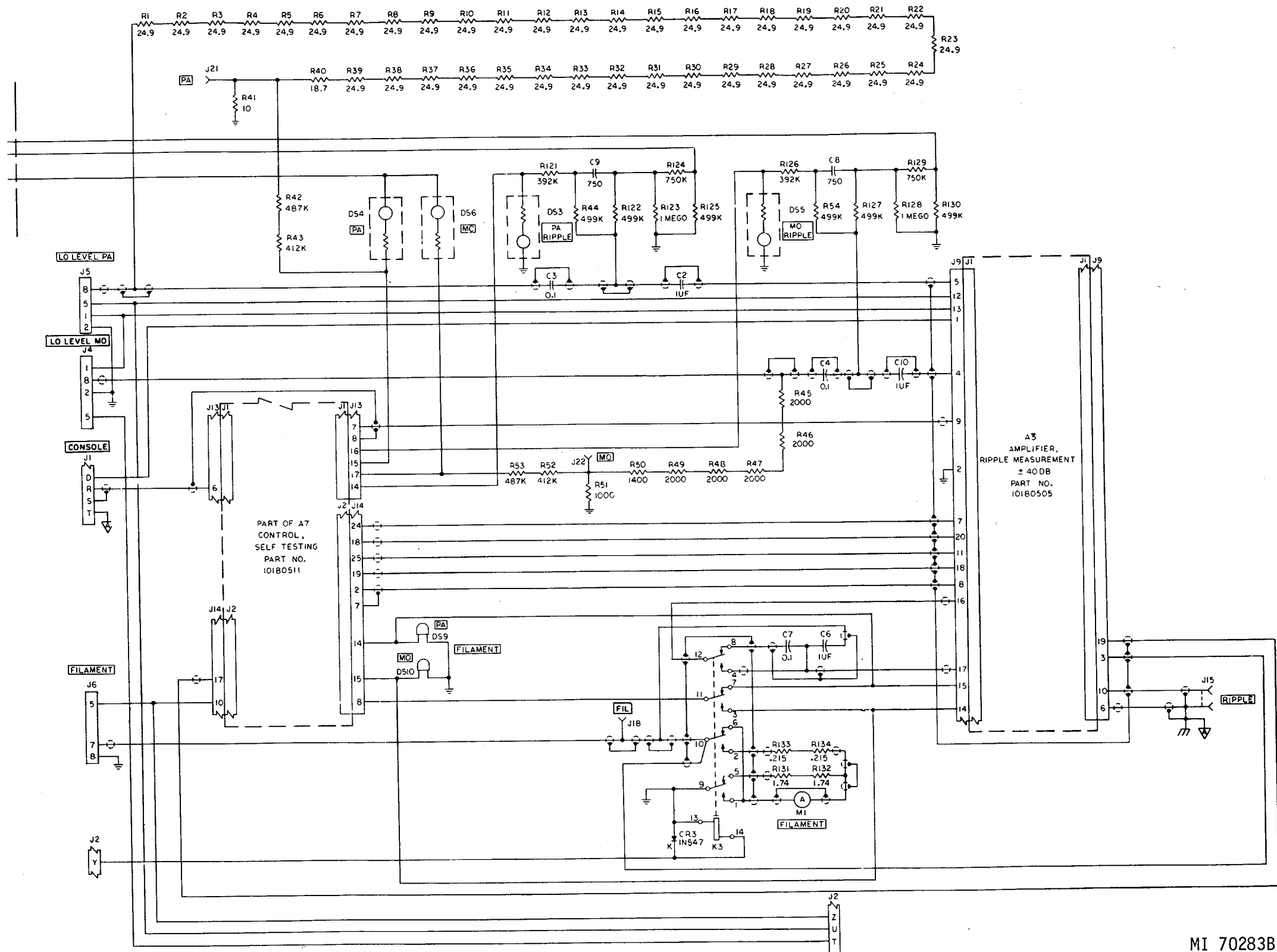

Note: Refer to appendix B for serial number effectivity.

Figure 3-262. Distribution box - dummy load 11566717 *(T), 10676830 *(R) (see note) (FG 1340) - schematic (sheet 3 of 3).

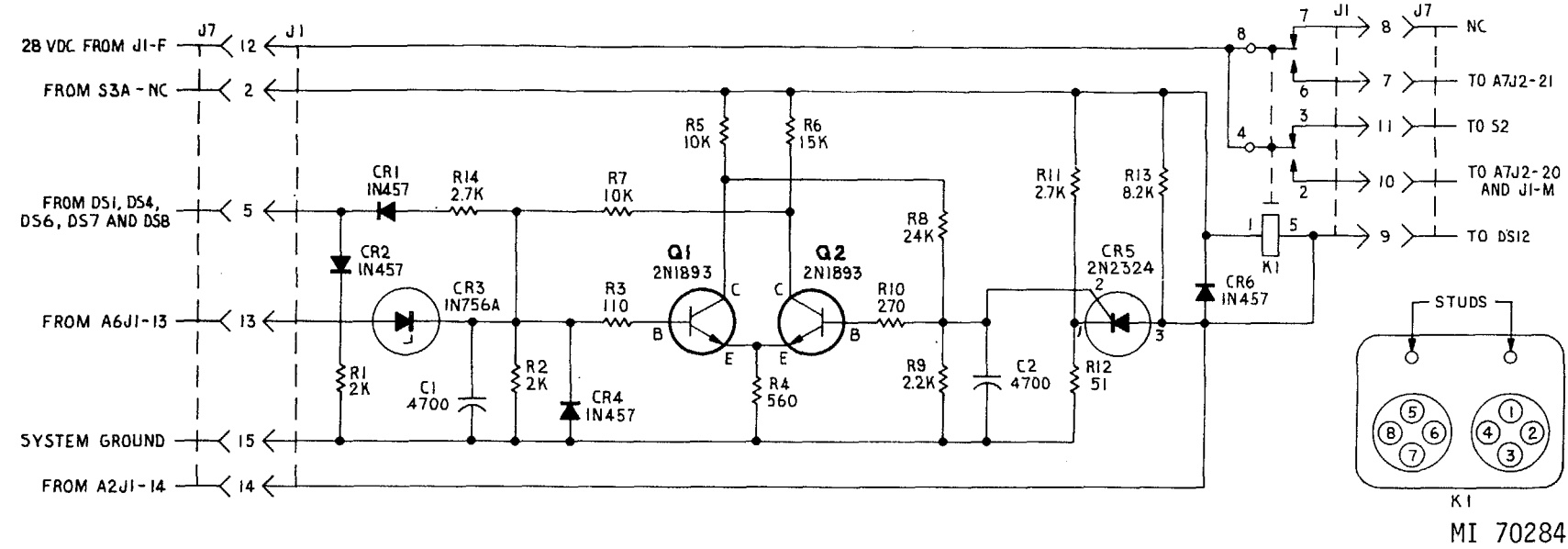

Figure 3-263. High-voltage shutoff control 10180400 (A1) (P/O FG 1340) - schematic.

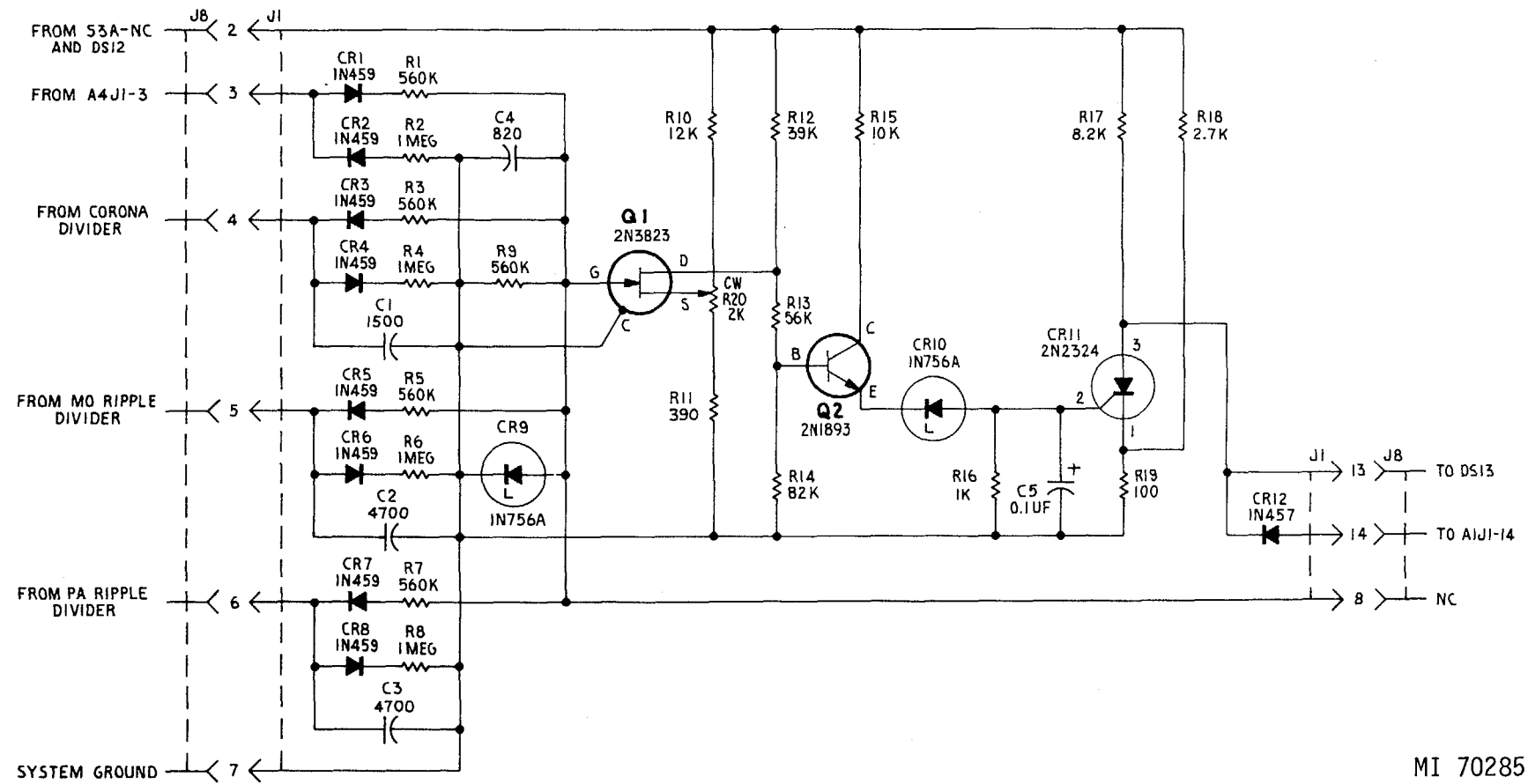

Figure 3-264. Relay electric control 10180277 (A2) (P/O FG 1340) - schematic.

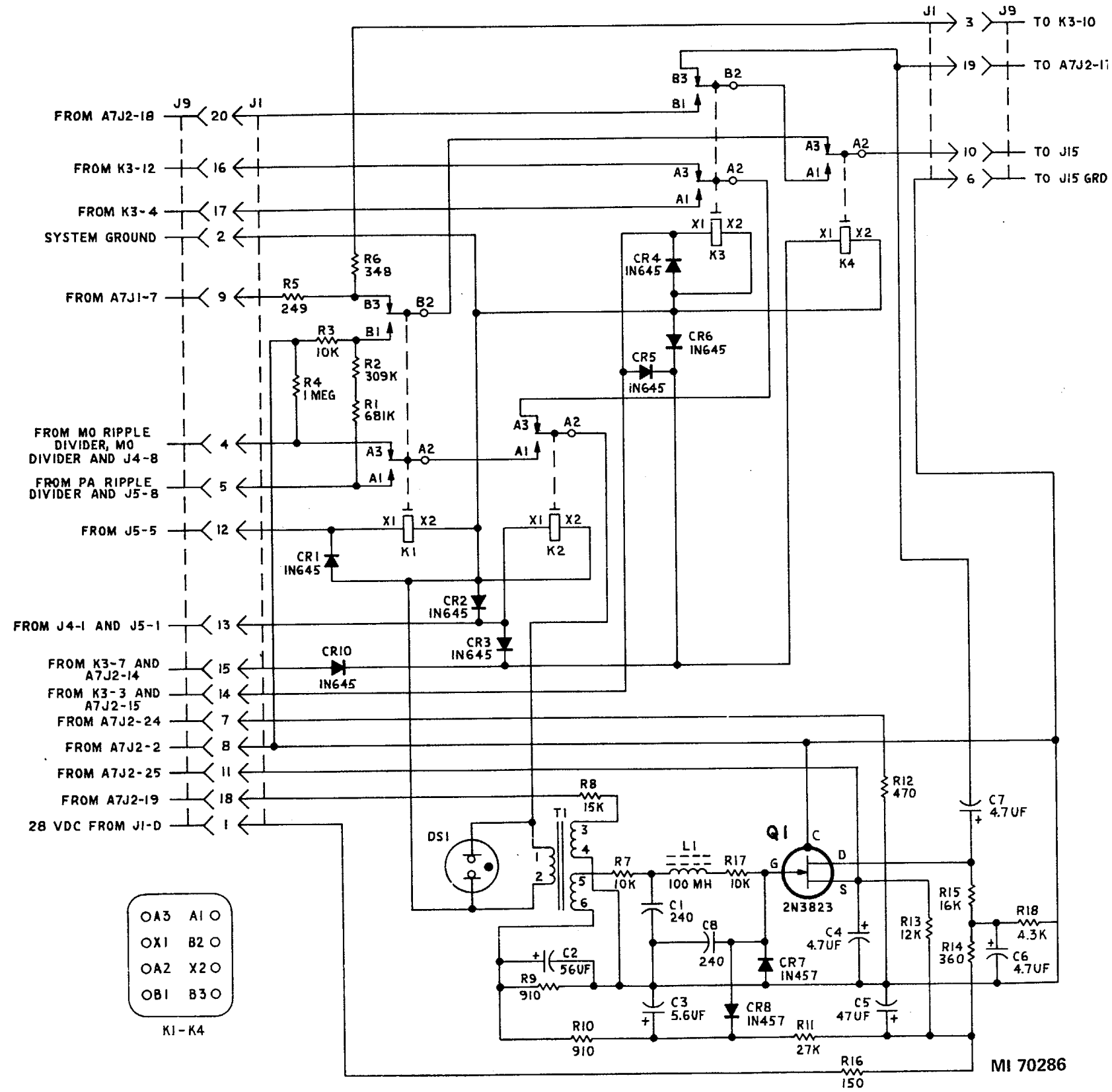

Figure 3-265. Ripple measurement amplifier 10180505 (A3) (P/O FG 1340) - schematic.

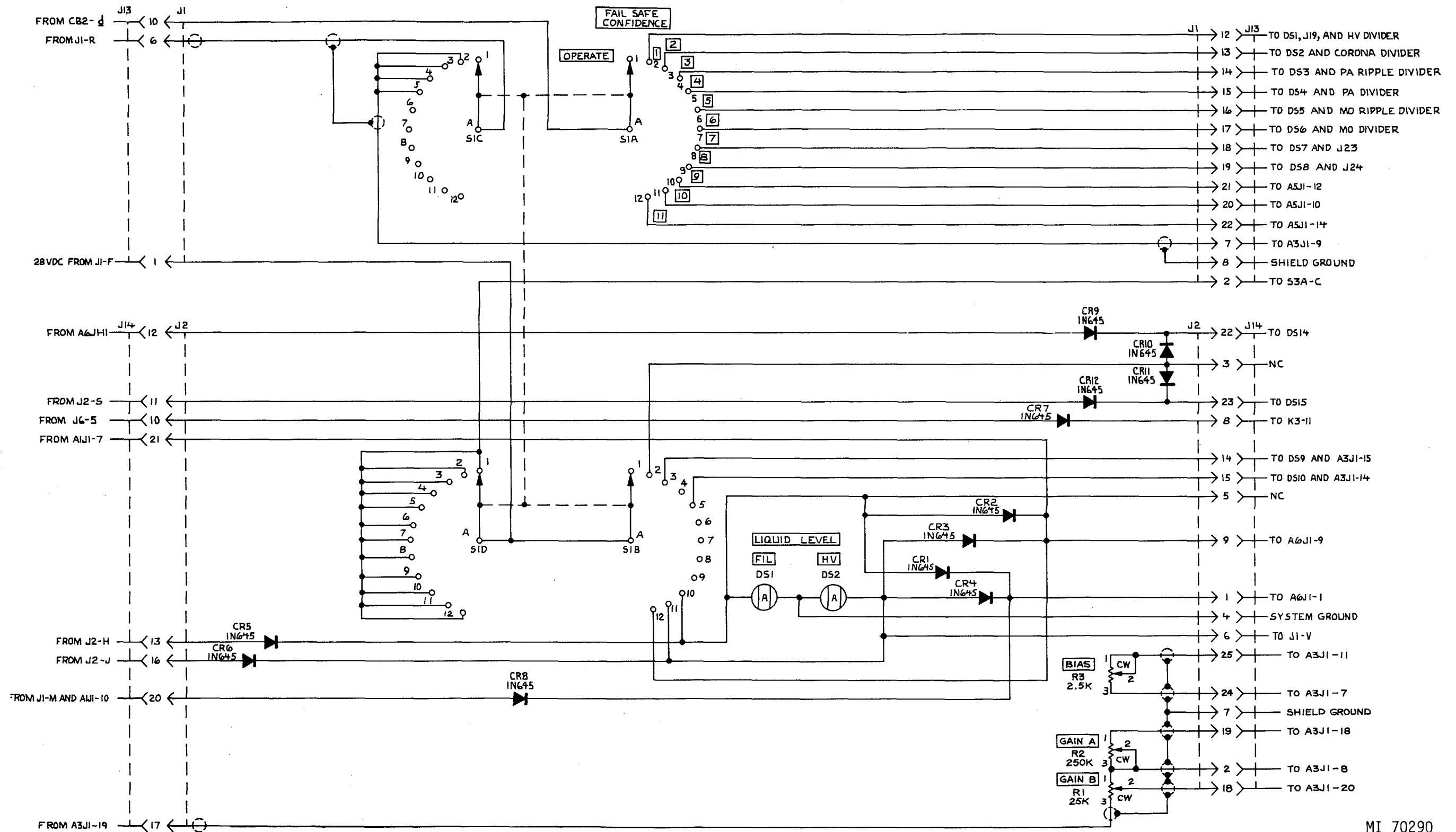

Figure 3-269. Self-test control 10180511 (A7) (P/O FG 1340) - schematic.

MI 70290

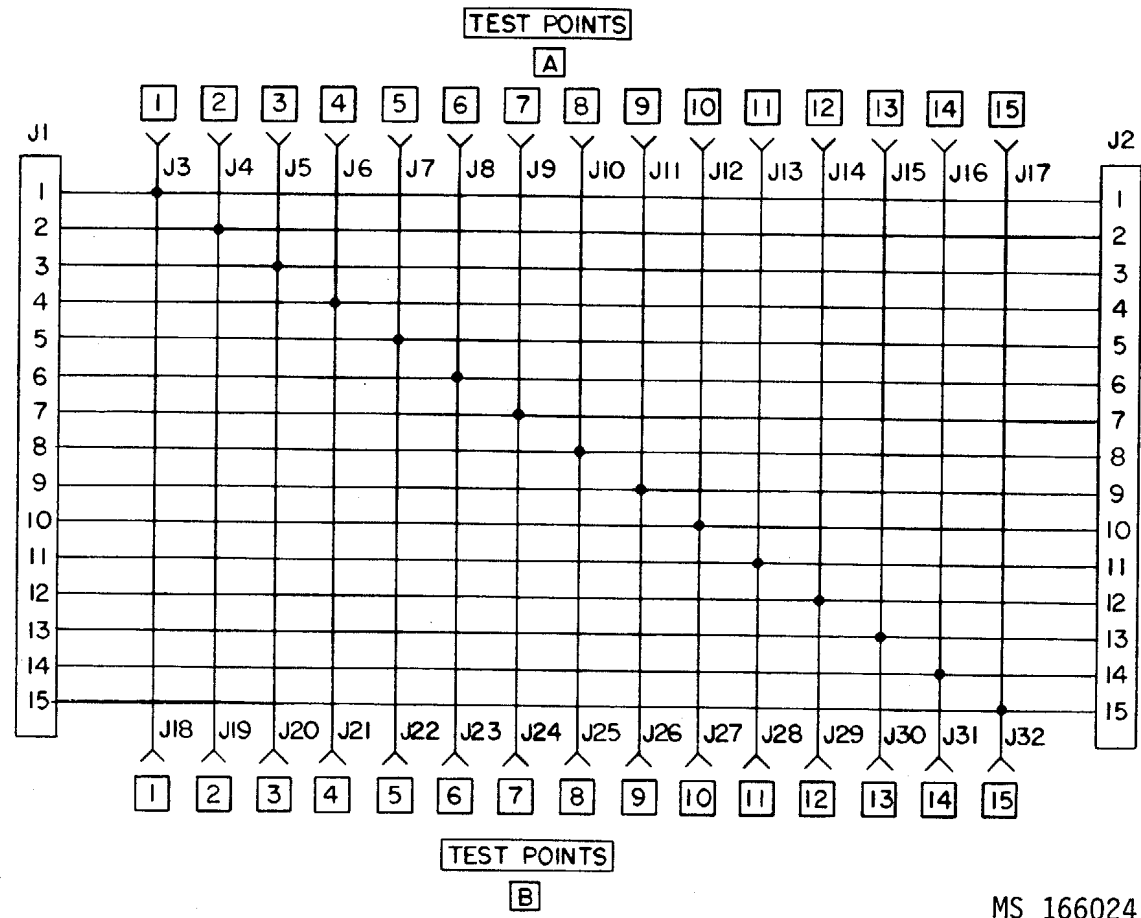

Figure 3-270. Test adapter, 15-point 10180555 - schematic.

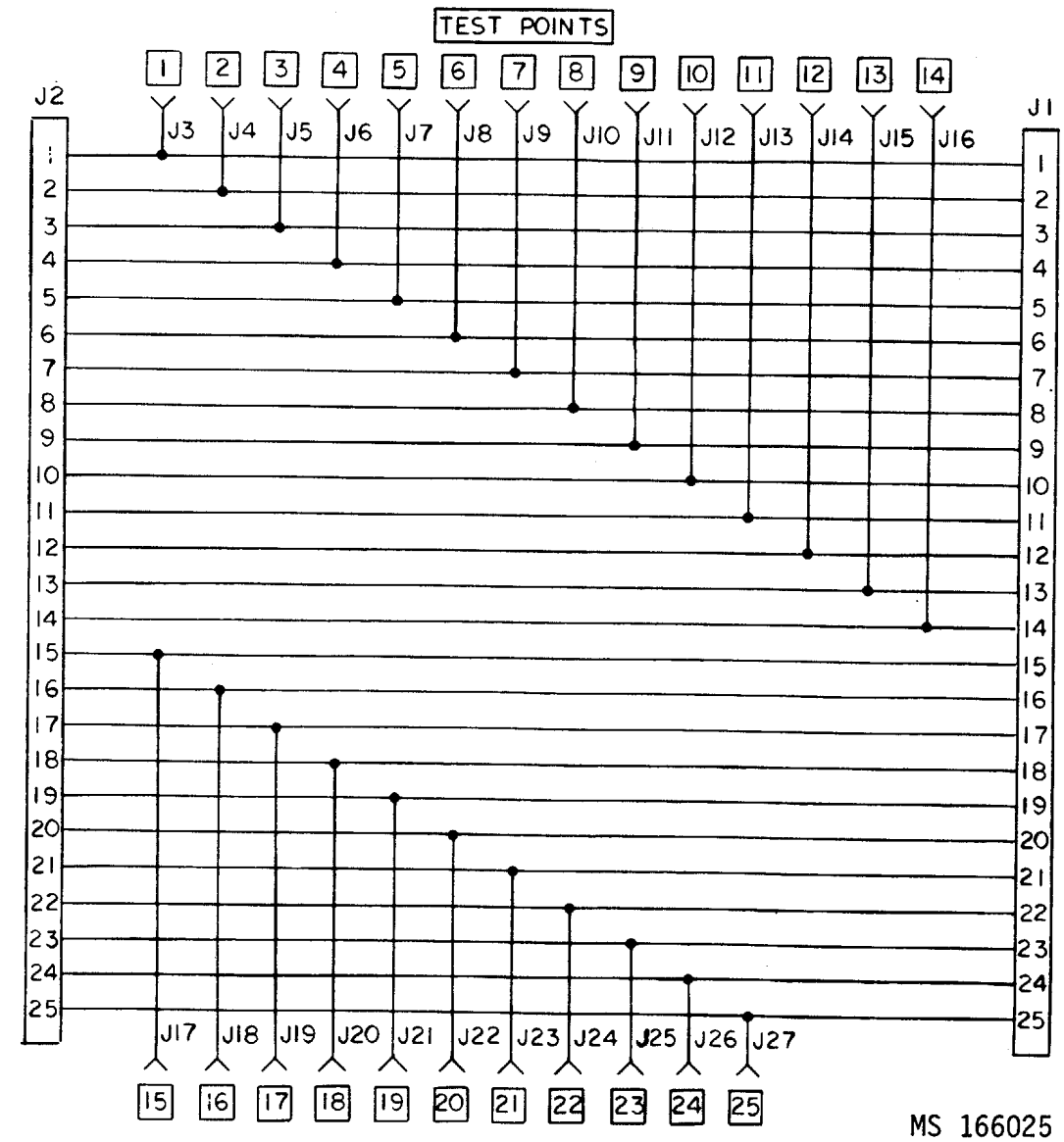

Figure 3-271. Test adapter, 25-point 10180513 - schematic.

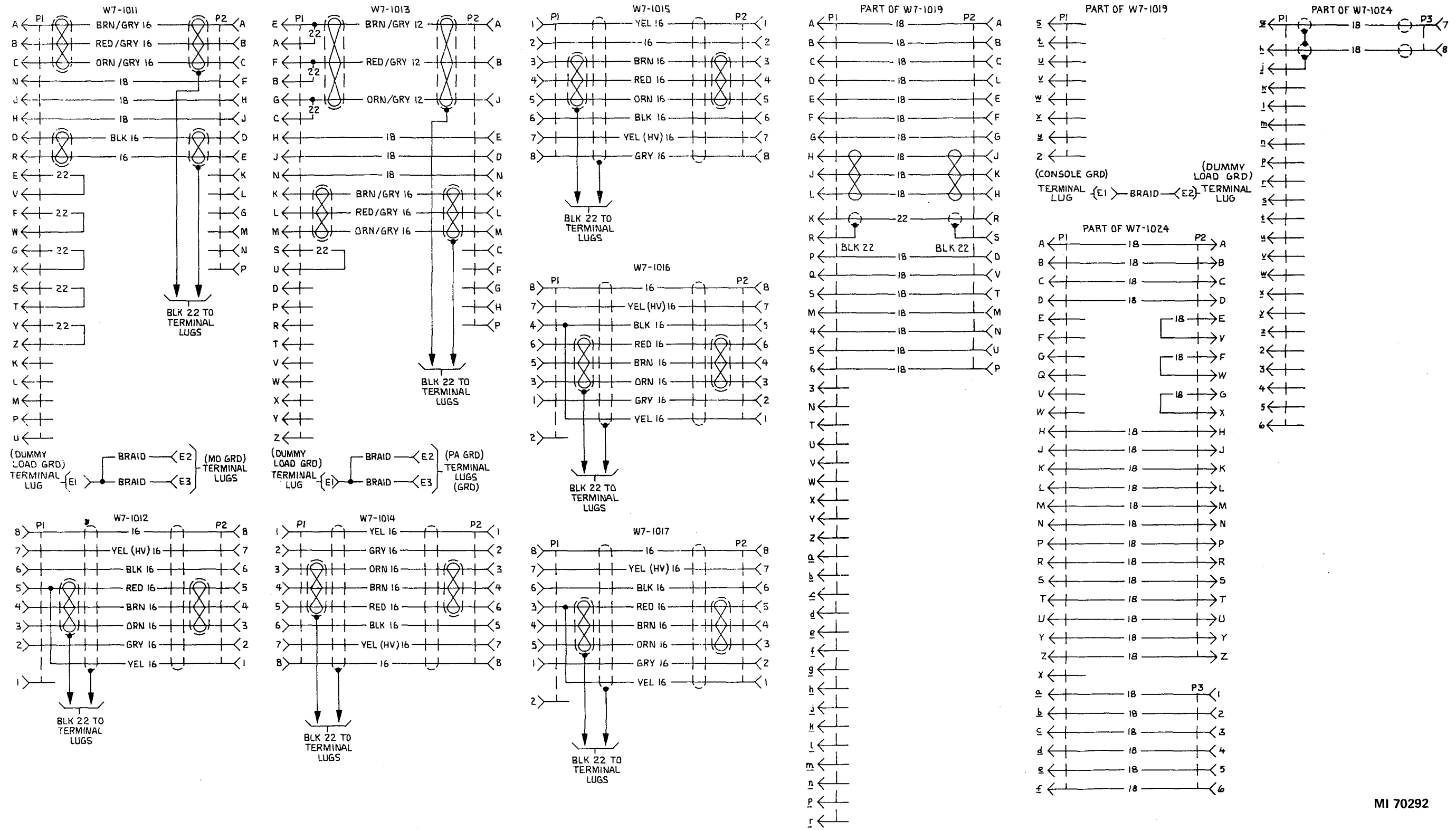

Figure 3-272. Test cables - schematic.

Section V. POWER SUPPLY TEST SET TF8-1019

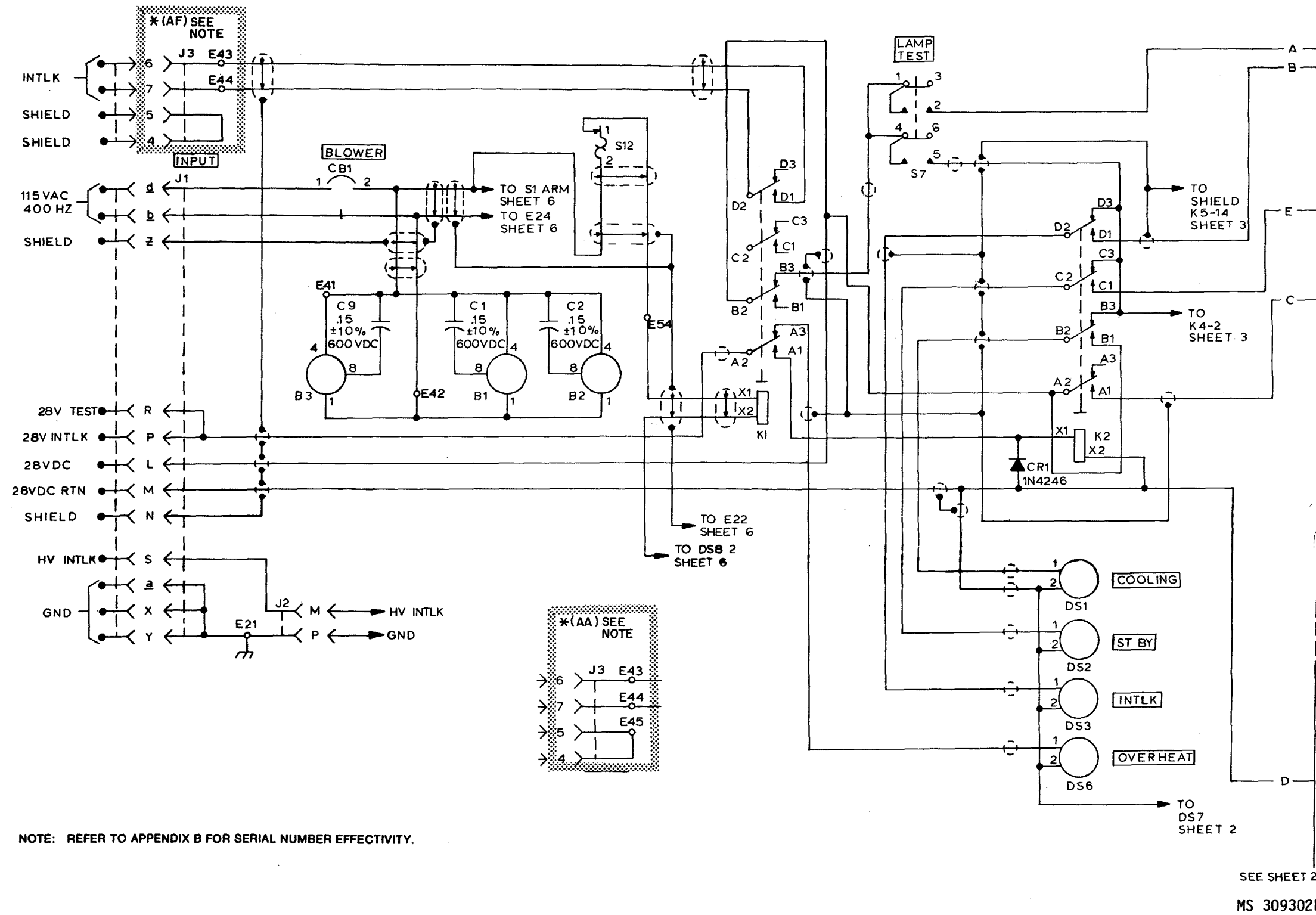
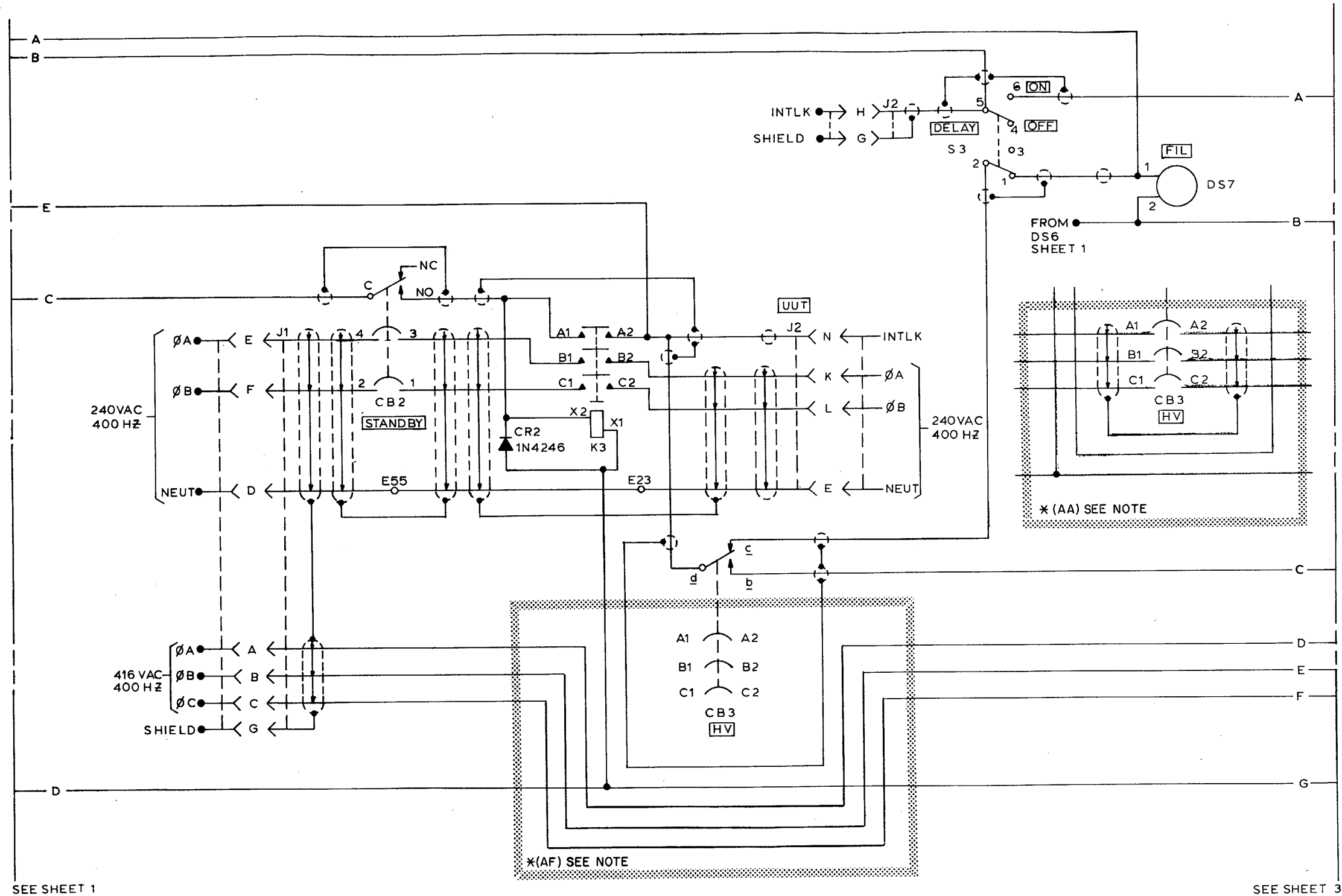

Figure 3-273. Power supply test set TF8-1019 11571393 *(AF), 11568699 *(AA), 11566018 *(Z) (see note) (FG 4400) - schematic (sheet 1 of 8).



NOTE: REFER TO APPENDIX B FOR SERIAL NUMBER EFFECTIVITY.

MS 309303B

Figure 3-273. Power supply test set TF8-1019 11571393 *(AF), 11568699 *(AA), 11566018 *(Z) (see note) (FG 4400) - schematic (sheet 2 of 8).

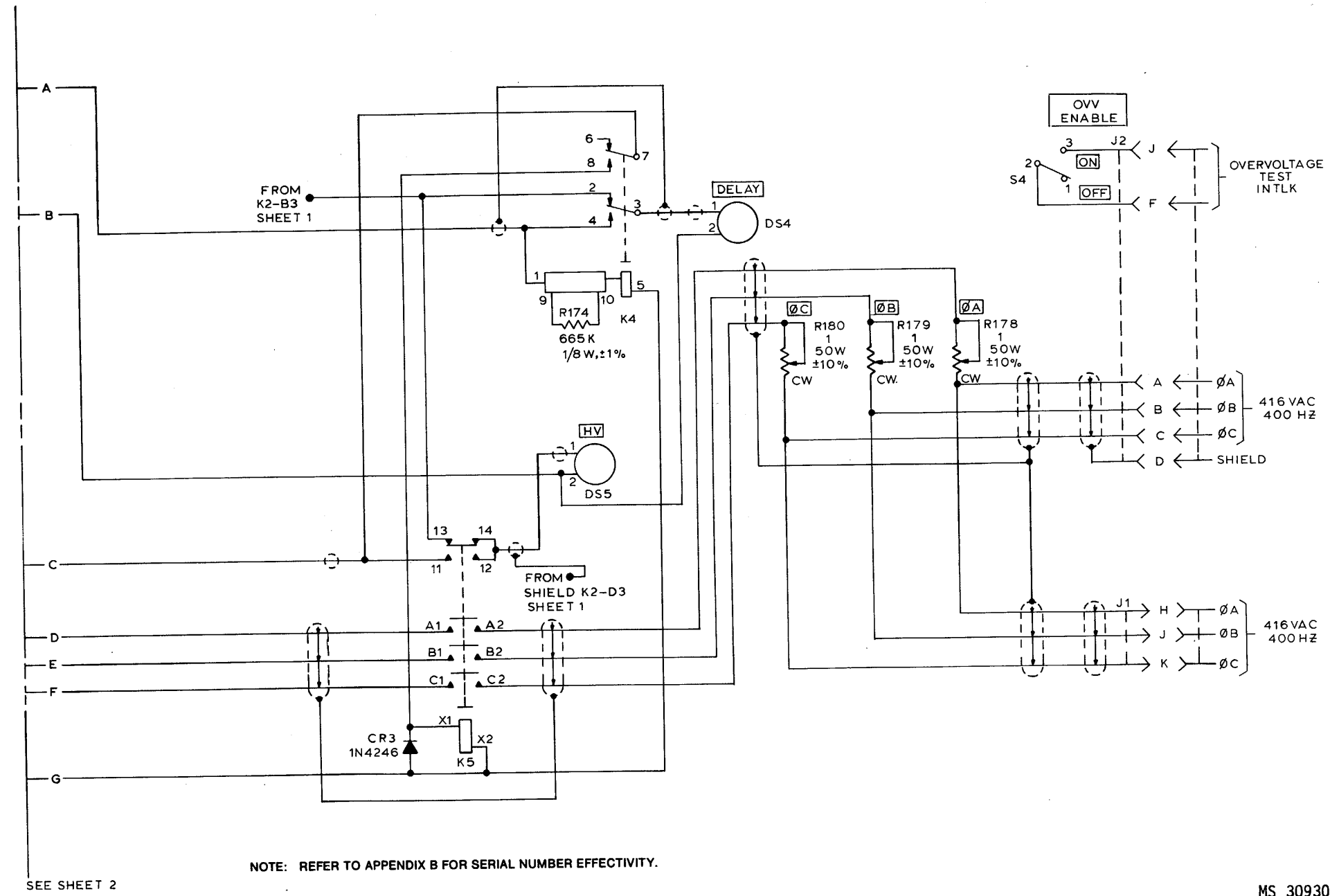
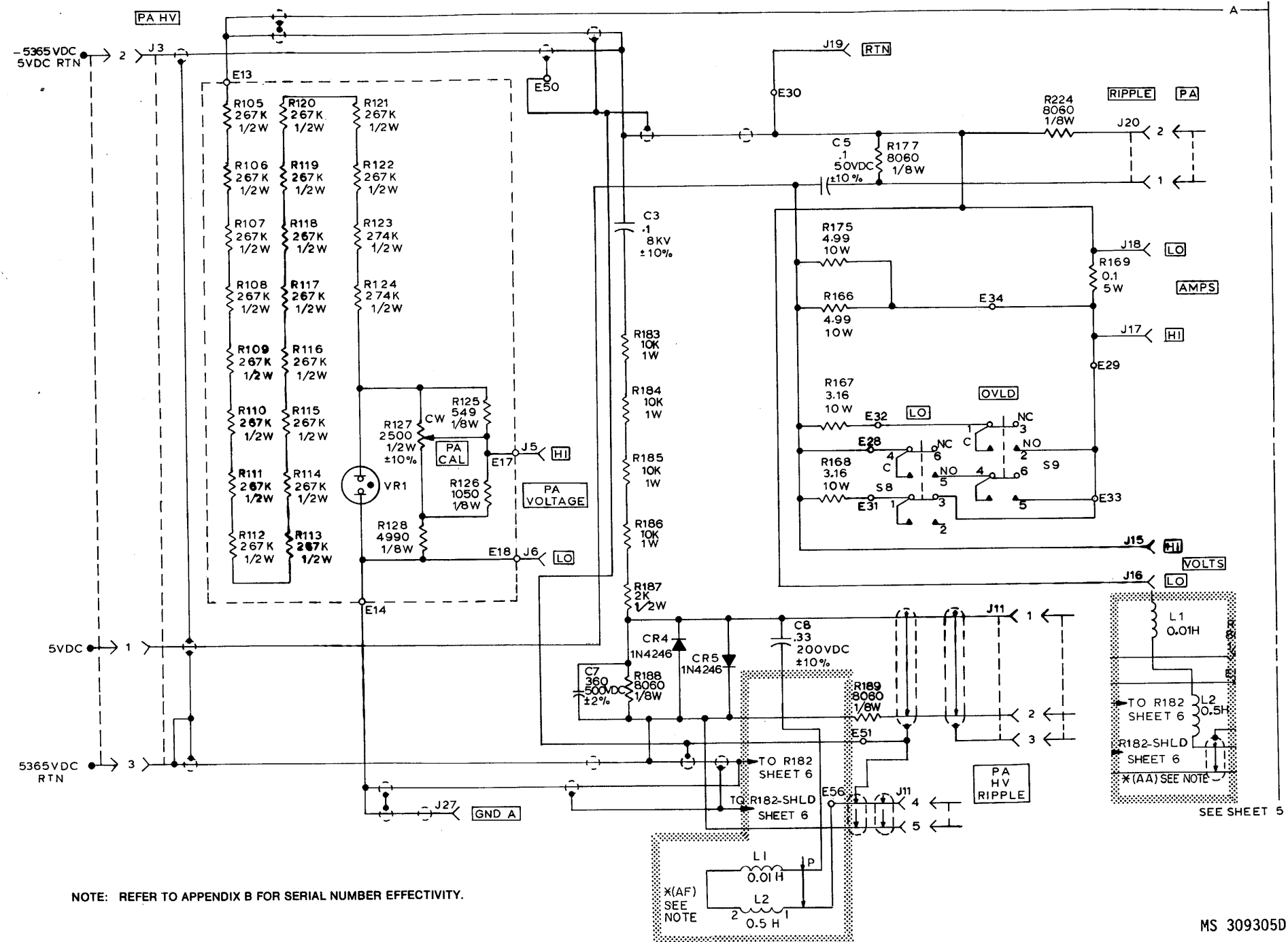

Figure 3-273. Power supply test set TF8-1019 11571393* (AF), 11568699* (AA), 11566018 (Z) (see note) (FG 4400) - schematic (sheet 3 of 8).



NOTE: REFER TO APPENDIX B FOR SERIAL NUMBER EFFECTIVITY.

MS 309305D

Figure 3-273. Power supply test set TF8-1019 11571393* (AF), 11568699* (AA), 11566018* (Z) (see note) (FG 4400) - schematic (sheet 4 of 8).

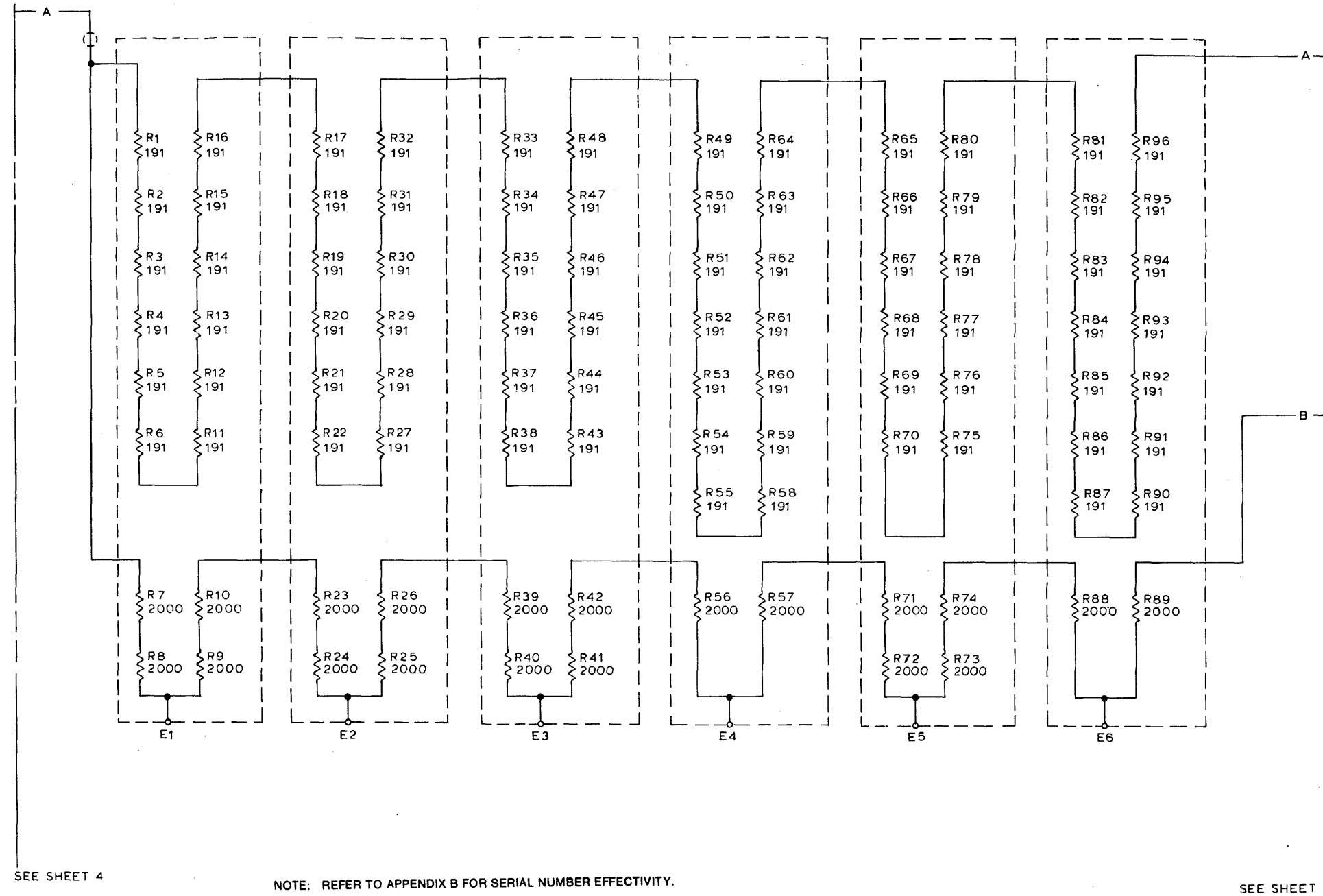

SEE SHEET 4

NOTE: REFER TO APPENDIX B FOR SERIAL NUMBER EFFECTIVITY.

SEE SHEET 6

MS 309306A

Figure 3-273. Power supply test set TF8-1019 11571393* (AF), 11568699* (AA), 11566018* (Z) (see note) (FG 4400) - schematic (sheet 5 of 8).

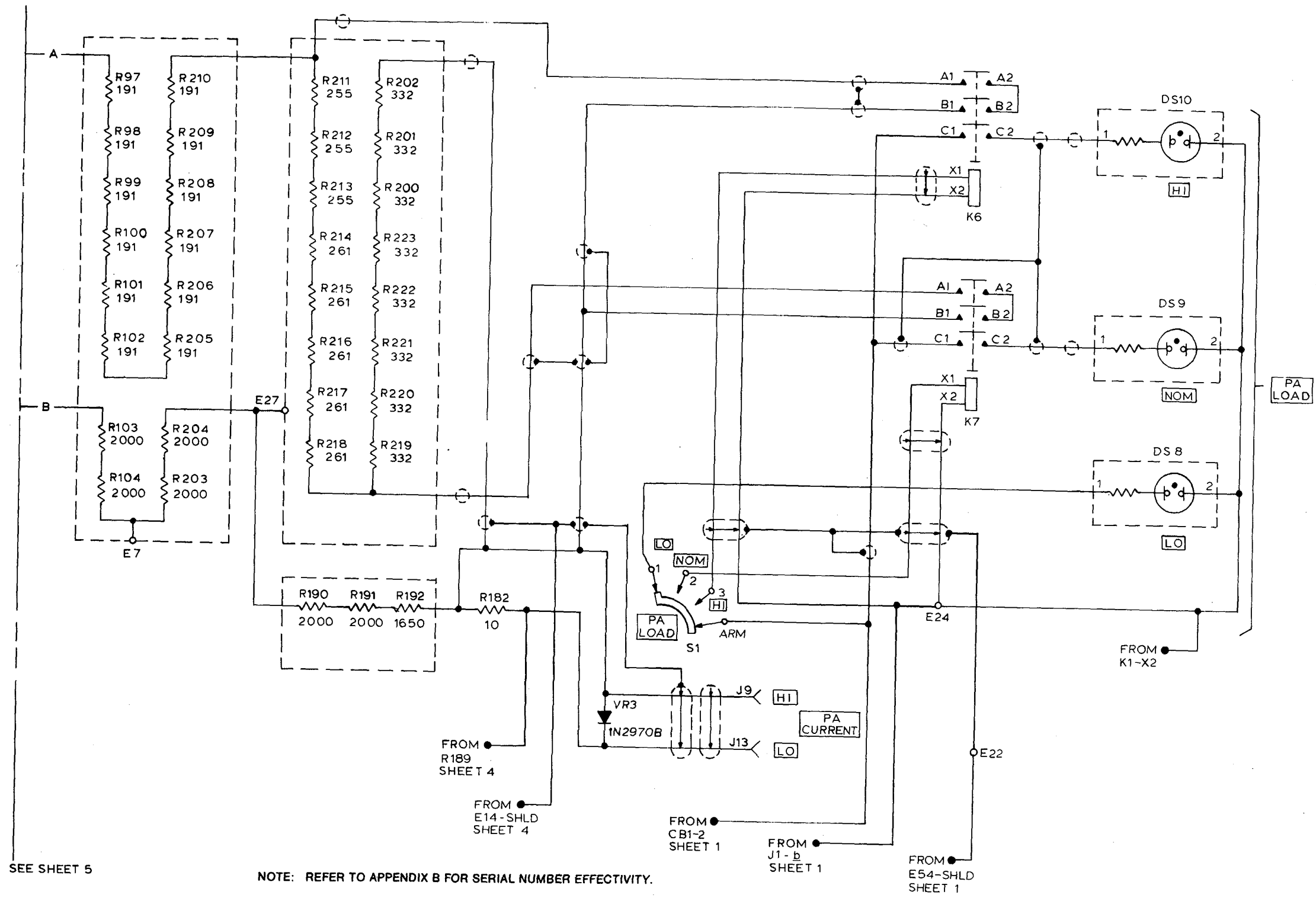

SEE SHEET 5

NOTE: REFER TO APPENDIX B FOR SERIAL NUMBER EFFECTIVITY.

MS 309307A

Figure 3-273. Power supply test set TF8-1019 11571393* (AF), 11562699* (AA), 11566018* (Z) (see note) (FG 4400) - schematic (sheet 6 of 8).

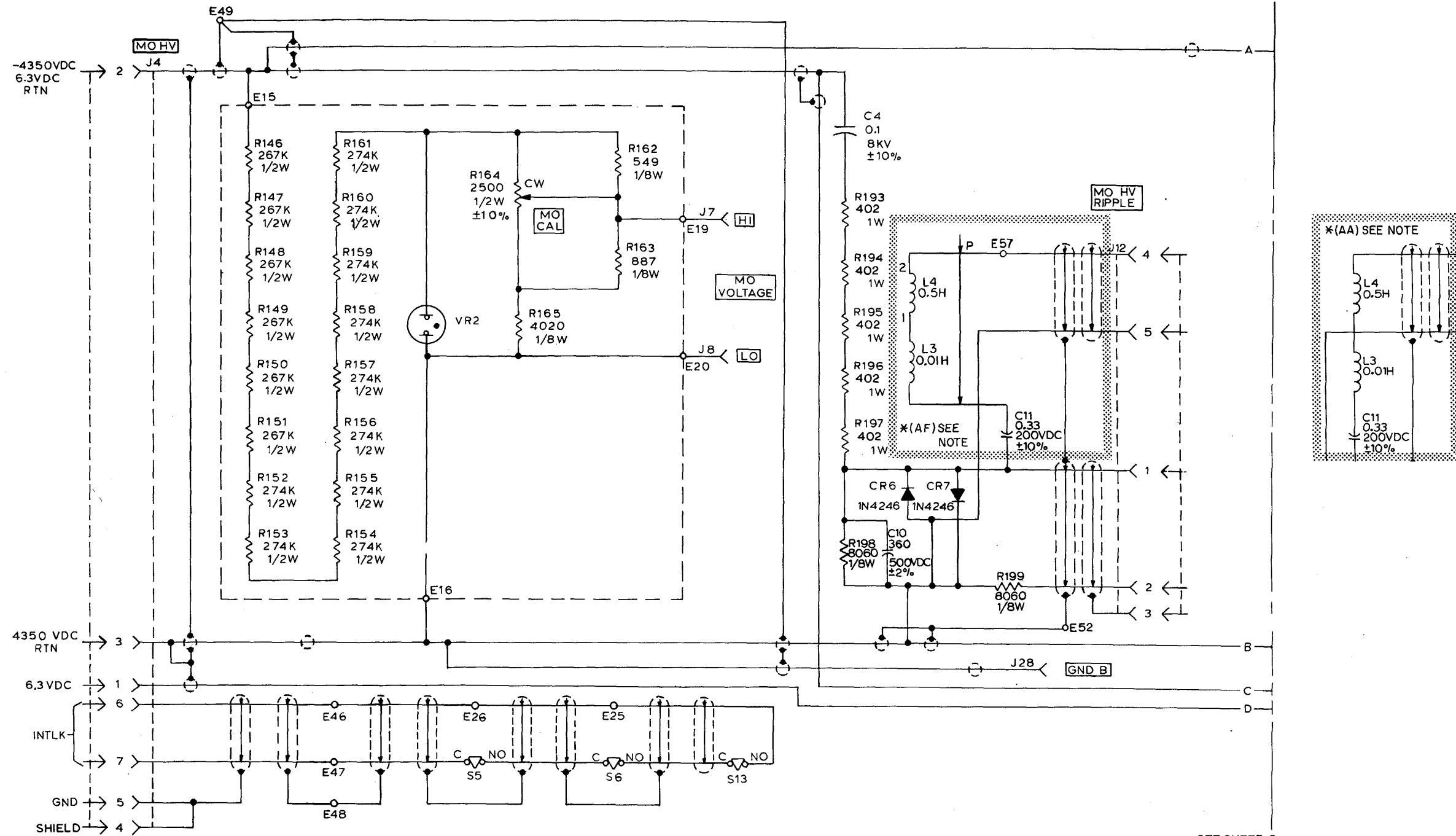

NOTE: REFER TO APPENDIX B FOR SERIAL NUMBER EFFECTIVITY.

SEE SHEET 8

MS 309308B

Figure 3-273. Power supply test set TF8-1019 11571393* (AF), 11568699* (AA), 11566018* (Z) (see note) (FG 4400) - schematic (sheet 7 of 8).

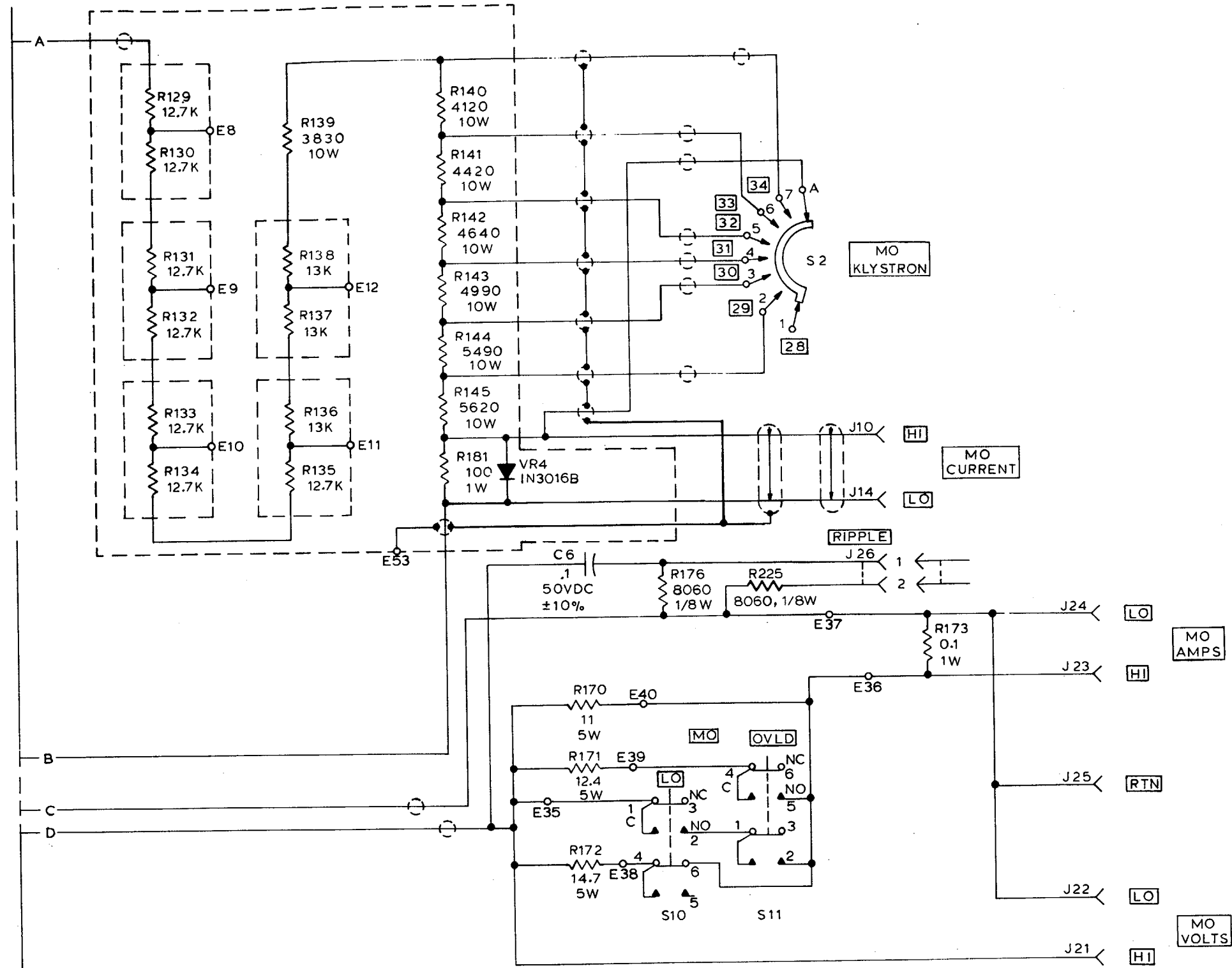

SEE SHEET 7

NOTE: REFER TO APPENDIX B FOR SERIAL NUMBER EFFECTIVITY.

MS 309309A

Figure 3-273. Power supply test set TF8-1019 11571393* (AF), 11568699* (AA), 11566018 (Z) (see note) (FG 4400) - schematic (sheet 8 of 8).

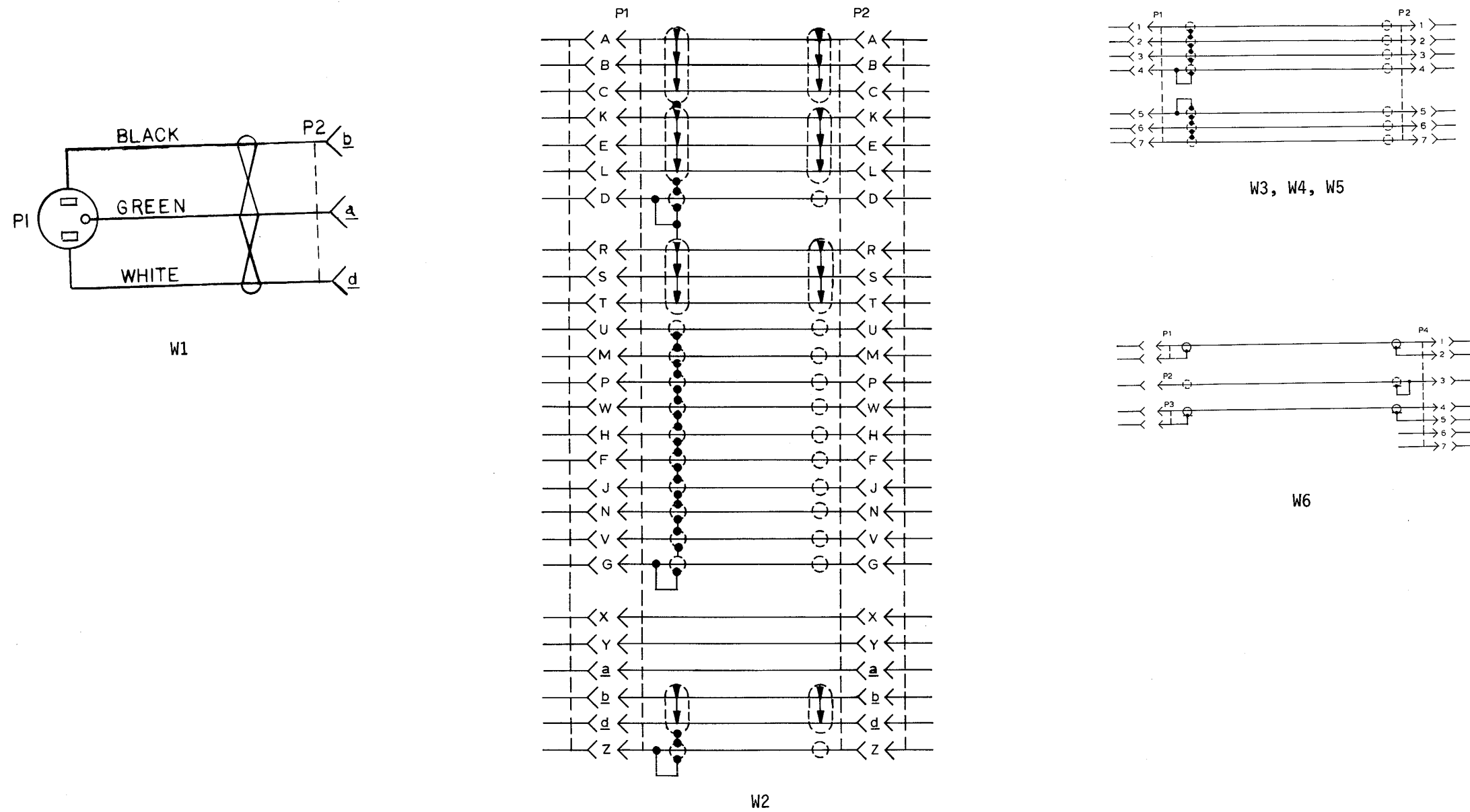
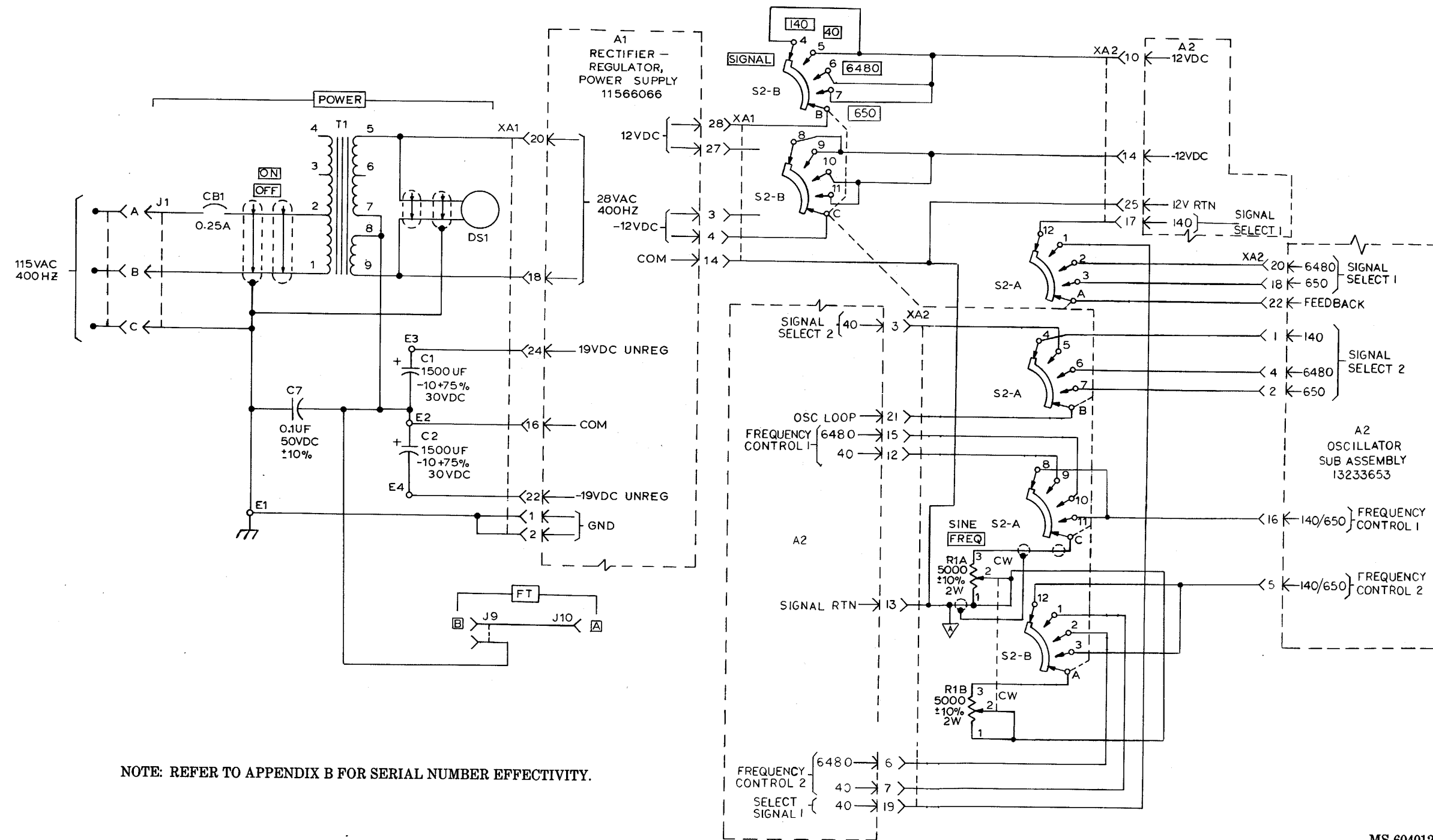

FIGURE 3-274. Power supply test set TF8-1019 test cables-schematic

Section VI. CALIBRATION TEST SET TF8-1020



NOTE: REFER TO APPENDIX B FOR SERIAL NUMBER EFFECTIVITY.

MS 604012

Figure 3-274.1 Calibration test set TF8-1020 13233663* (AQ), (see note) (FG 4380) - schematic (sheet 1 of 3).

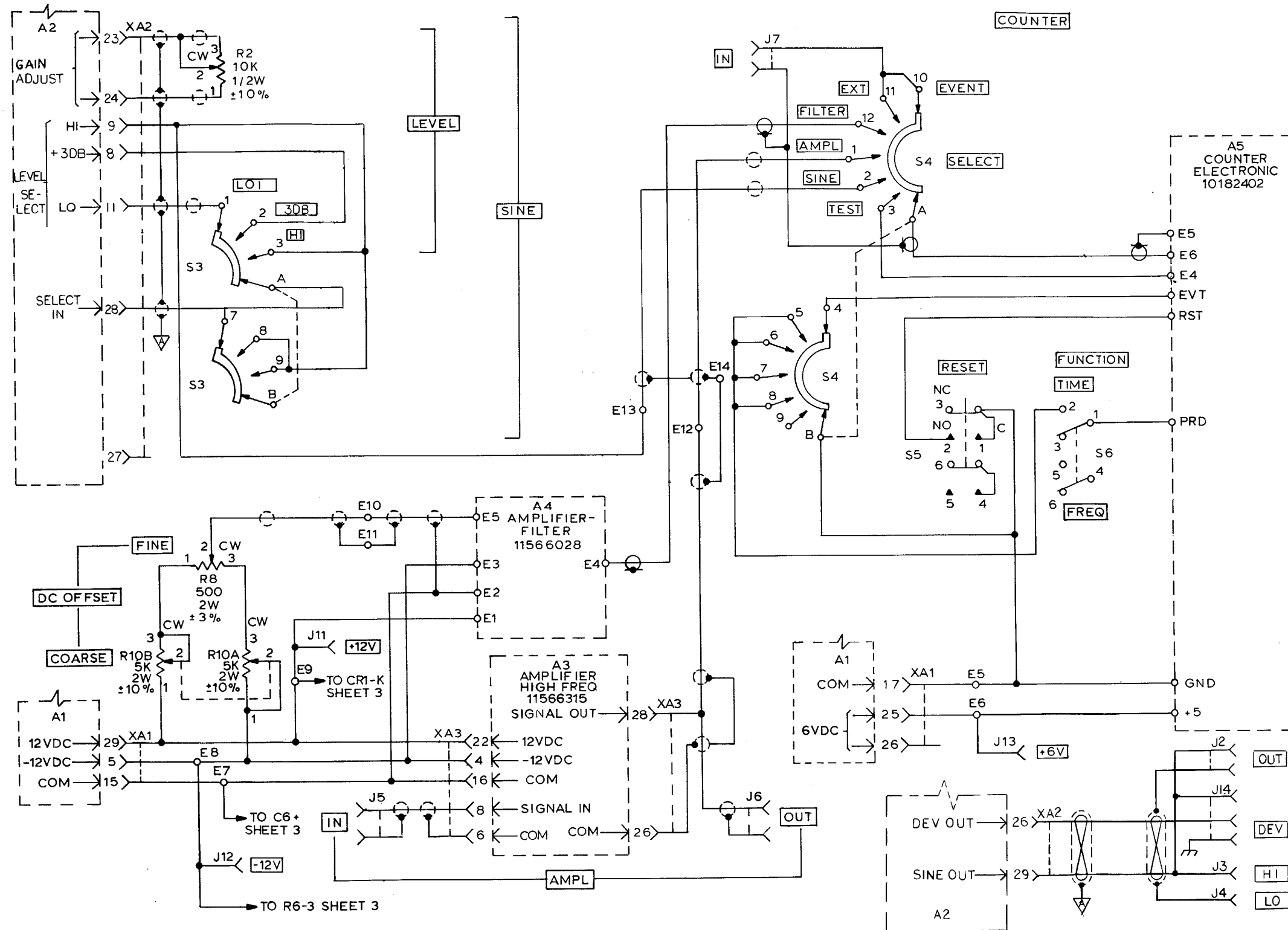

NOTE: REFER TO APPENDIX B FOR SERIAL NUMBER EFFECTIVITY.

MS 604013

Figure 3-274.1 Calibration test set TF8-1020 13233663* (AQ), (see note) (FG 4380) - schematic (sheet 2 of 3).

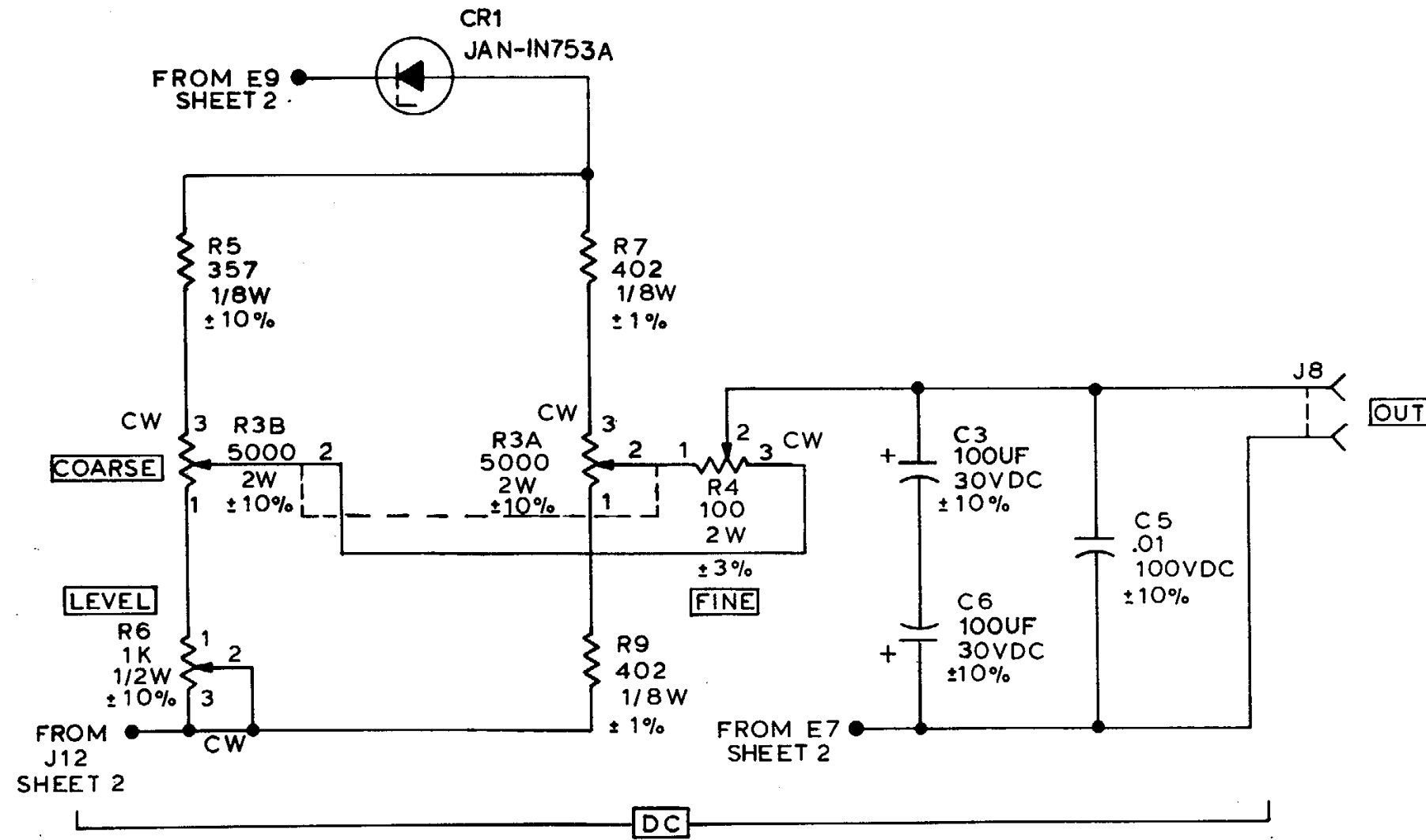

NOTE: REFER TO APPENDIX B FOR SERIAL NUMBER EFFECTIVITY.

MS 604014

Figure 3-274.1 Calibration test set TF8-1020 13233663* (AQ), (see note) (FG 4380) - schematic (sheet 3 of 3).

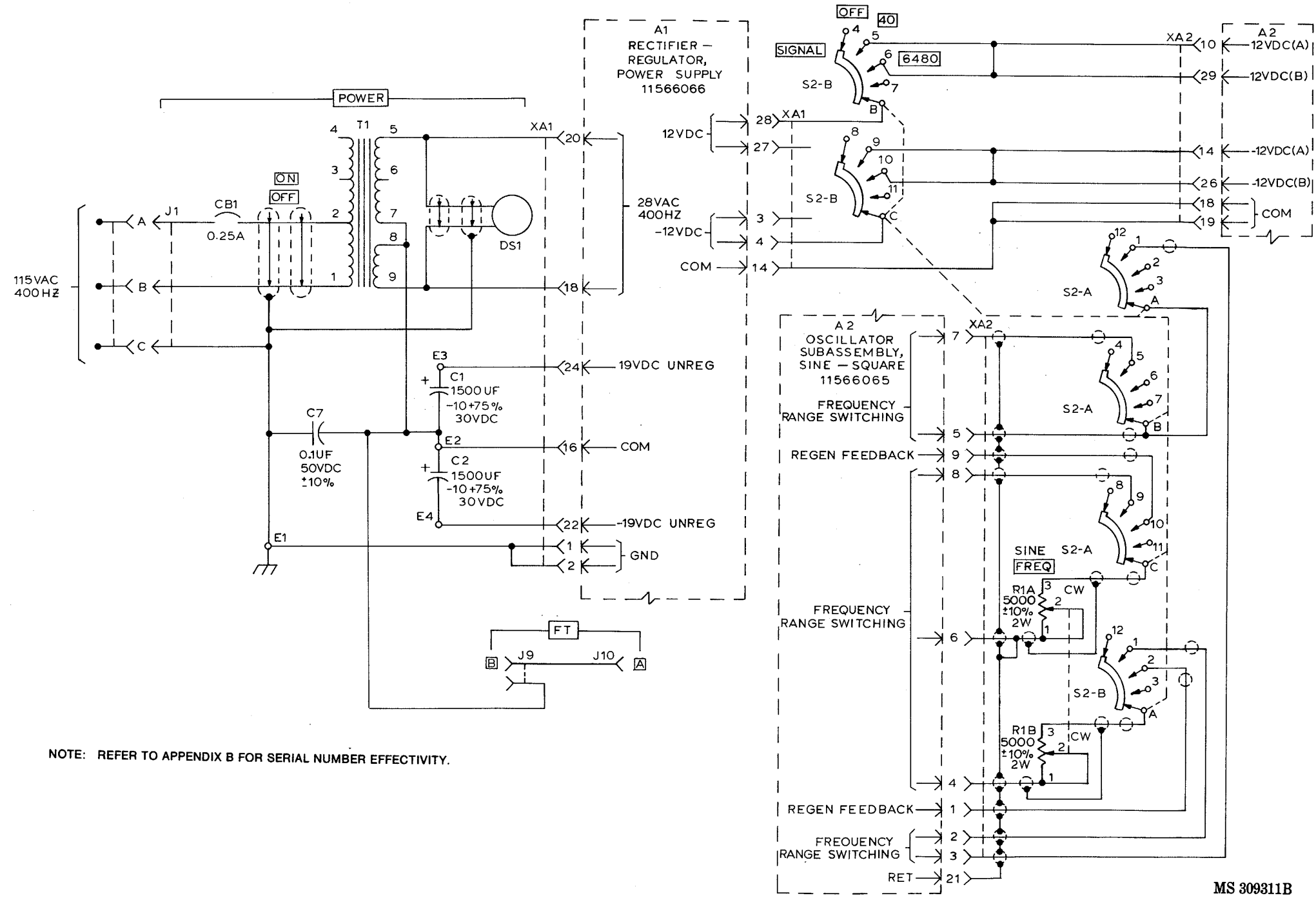

Figure 3-275. Calibration test set TF8-1020 11570924* (AP), (see note) (FG 4380) - schematic (sheet 1 of 3).

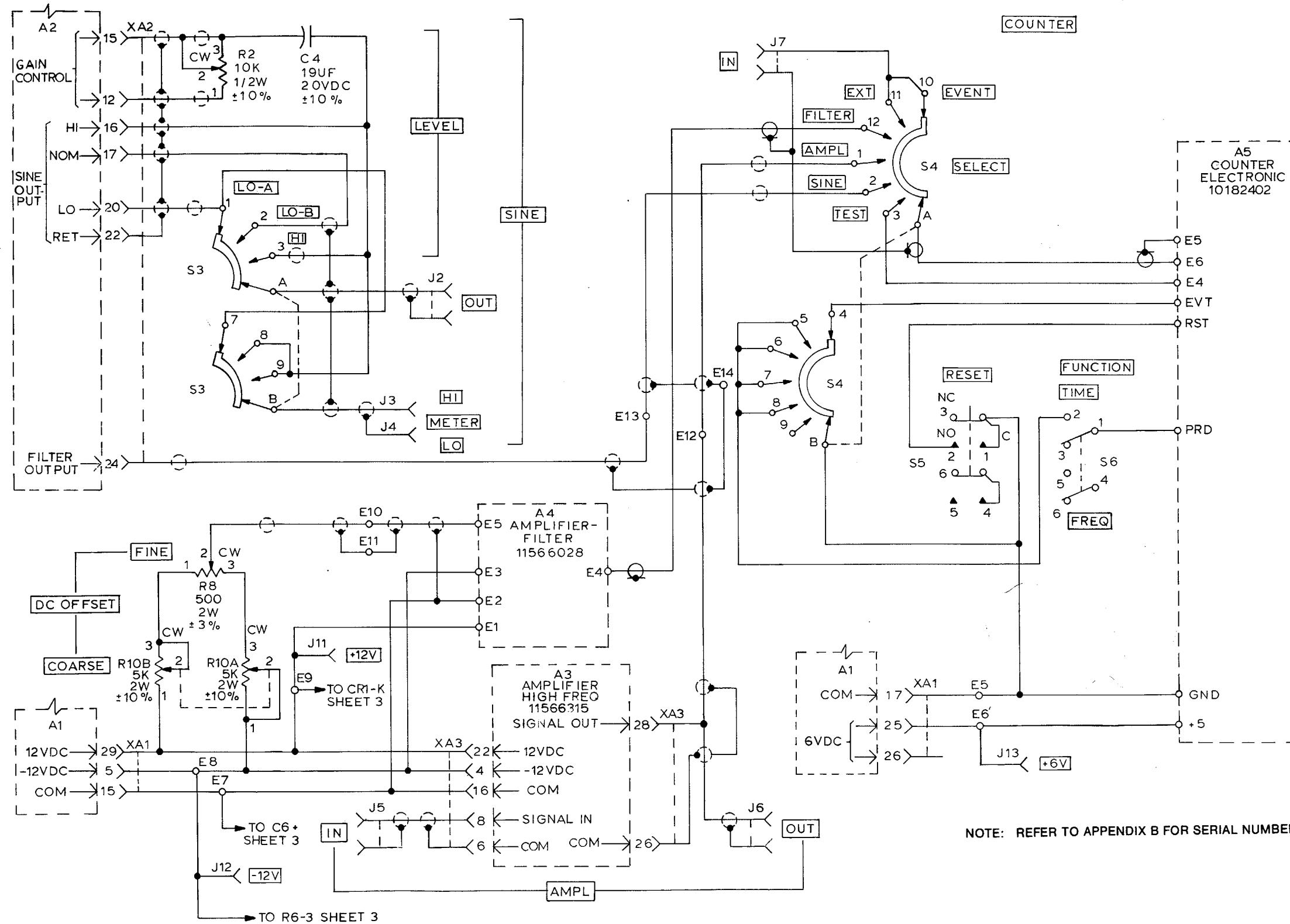
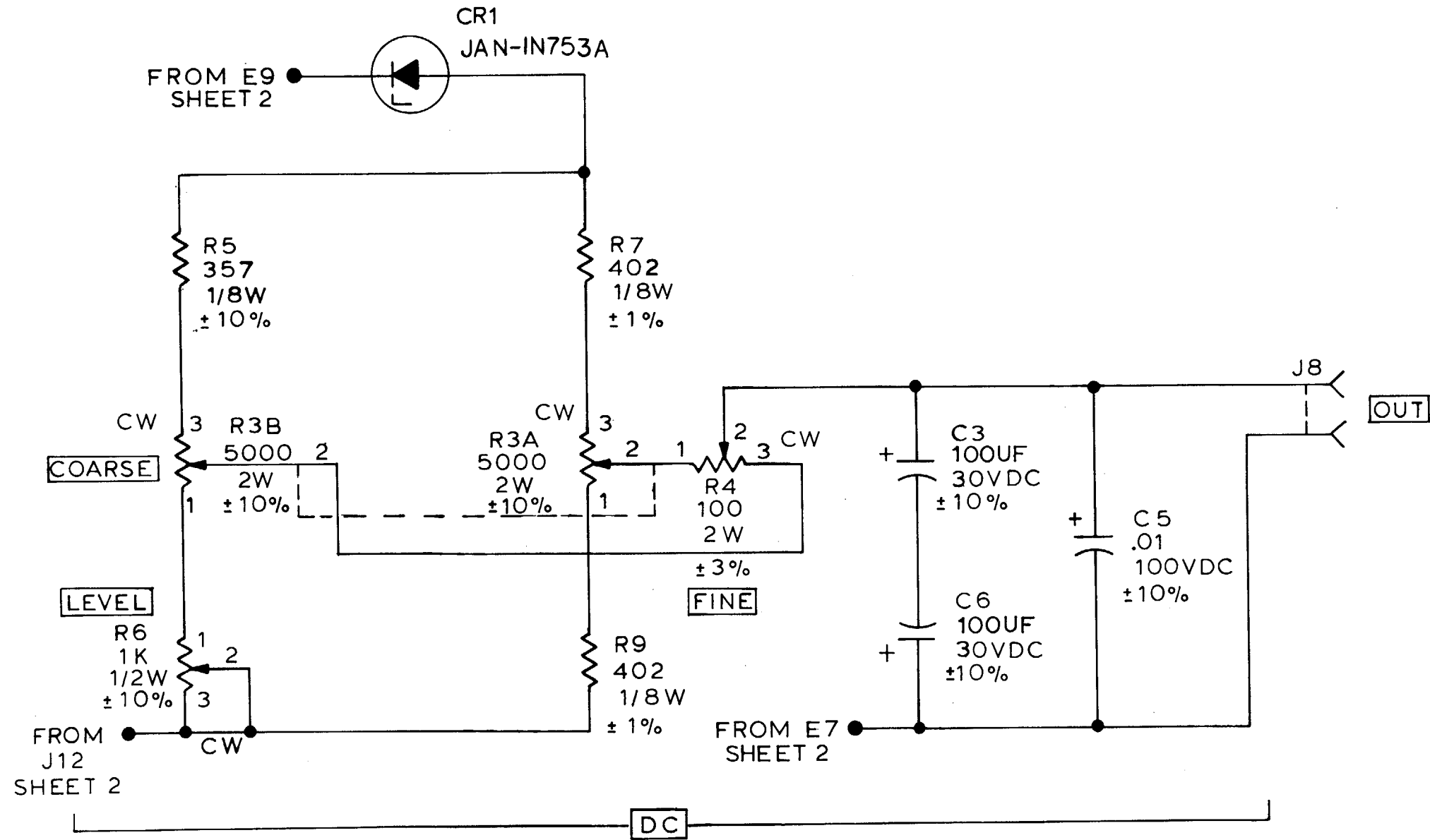

Figure 3-275. Calibration test set TF8-1020 11570924*(AP) (see note) (FG 4380) - schematic (sheet 2 of 3)



NOTE: REFER TO APPENDIX B FOR SERIAL NUMBER EFFECTIVITY.

MS 309313B

Figure 3-275. Calibration test set TF8-1020 11570924*(AP) (see note) (FG 4380) - schematic (sheet 2 of 3)

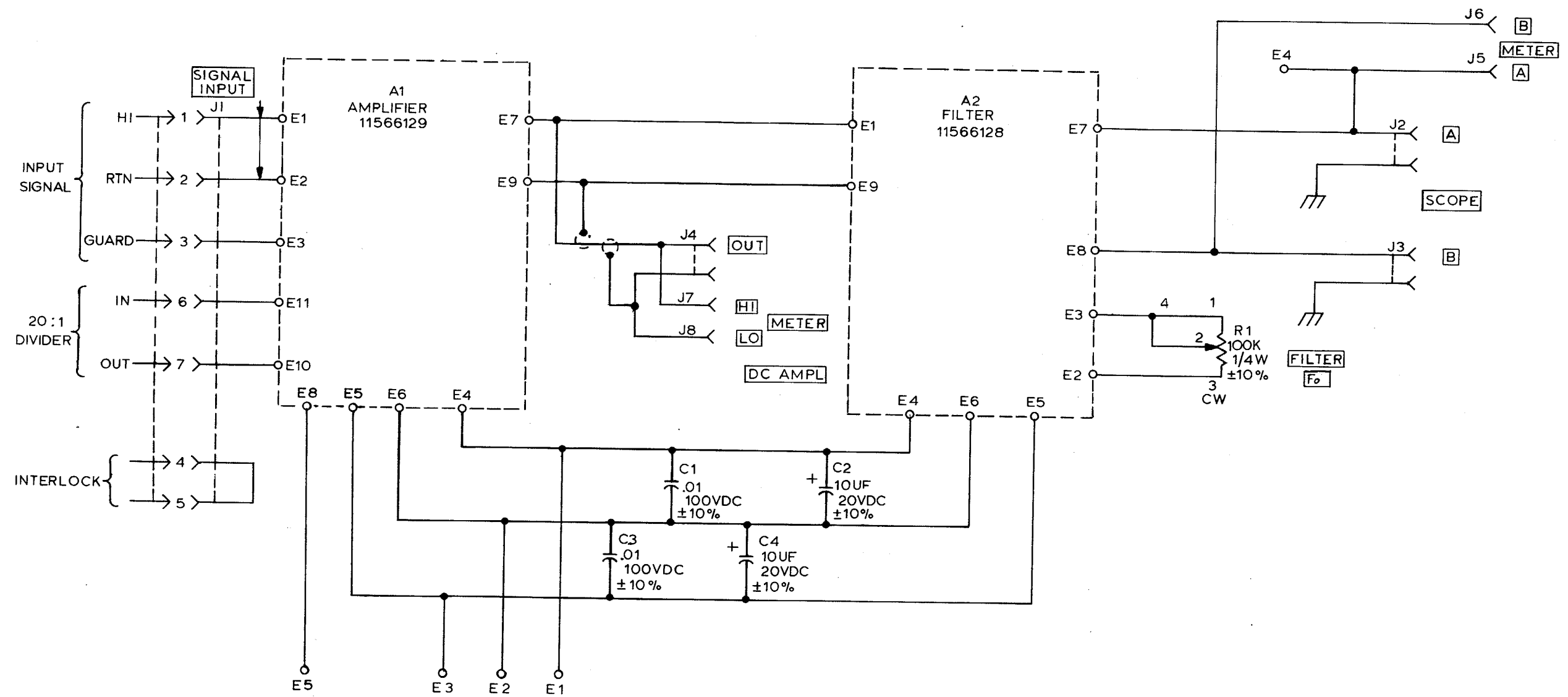

MS 309314

Figure 3-276. Amplifier-filter 11566028 (A4) (FG 4385) - schematic.

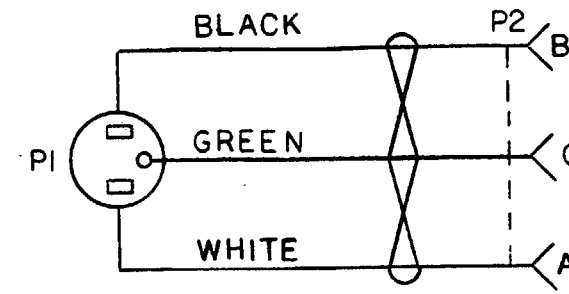

W1

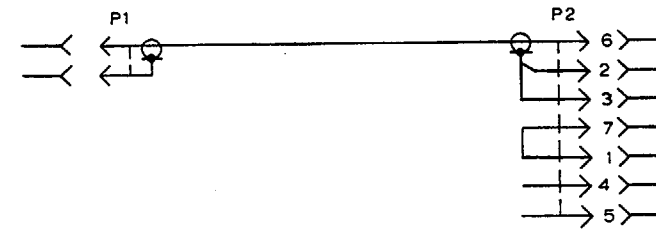
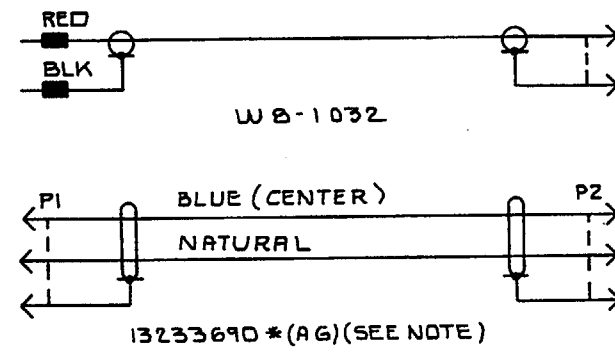

W2

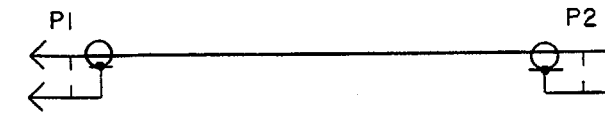

W4, W-030

NOTE: REFER TO APPENDIX B FOR SERIAL NUMBER EFFECTIVITY.

MS 309315A

Figure 3-277. Calibration tests set TF8-1020 test cables - schematic.

Section VII.
HIGH-VOLTAGE REGULATOR TEST SET TF8-1021

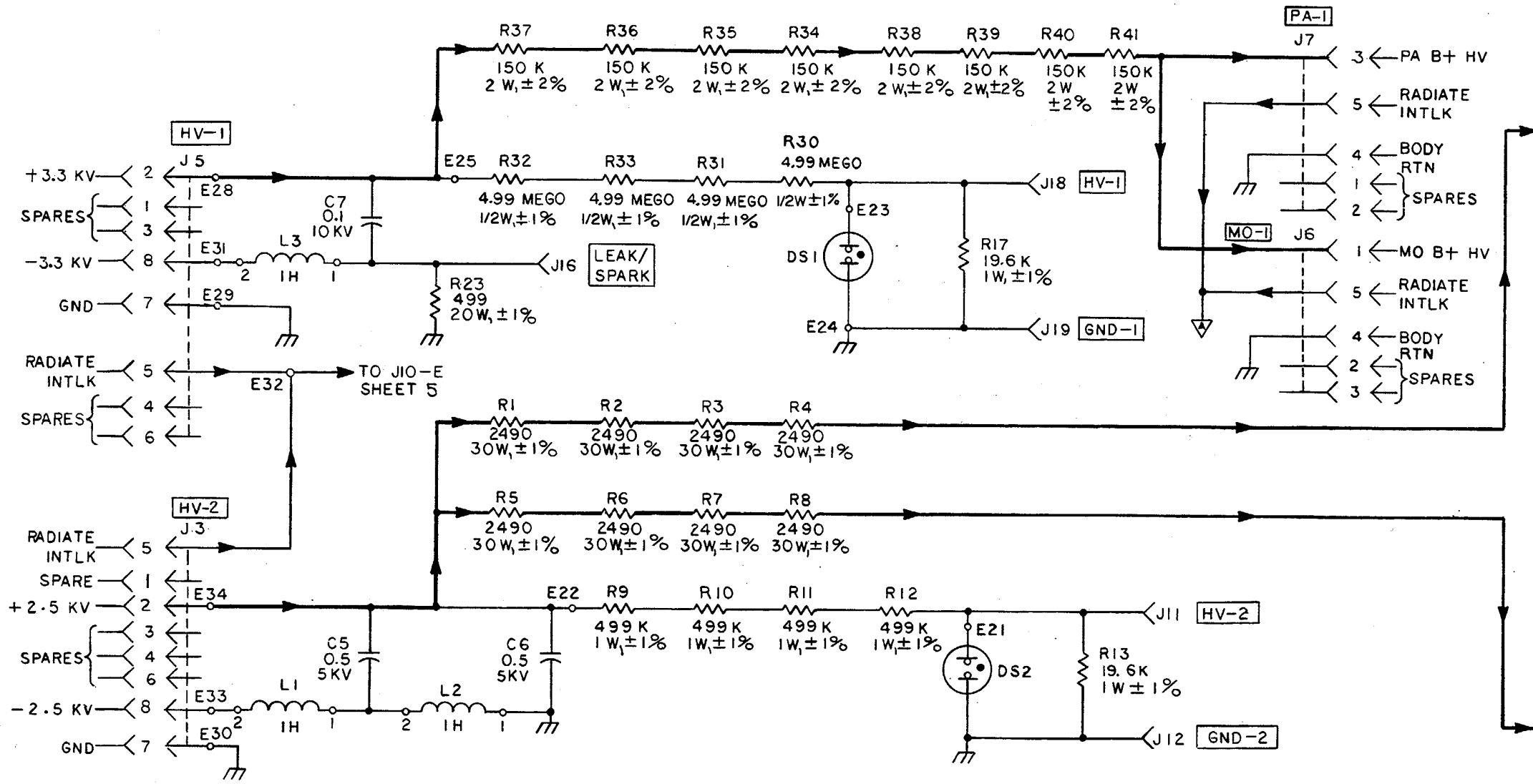

NOTE: REFER TO APPENDIX B FOR SERIAL NUMBER EFFECTIVITY.

SHEET 2

MS 433426B

Figure 3-278. High-voltage regulator test set TF8-1021 11570859 *(AE), *(AV) (see note) (FG 1000) - schematic (sheet 1 of 7).

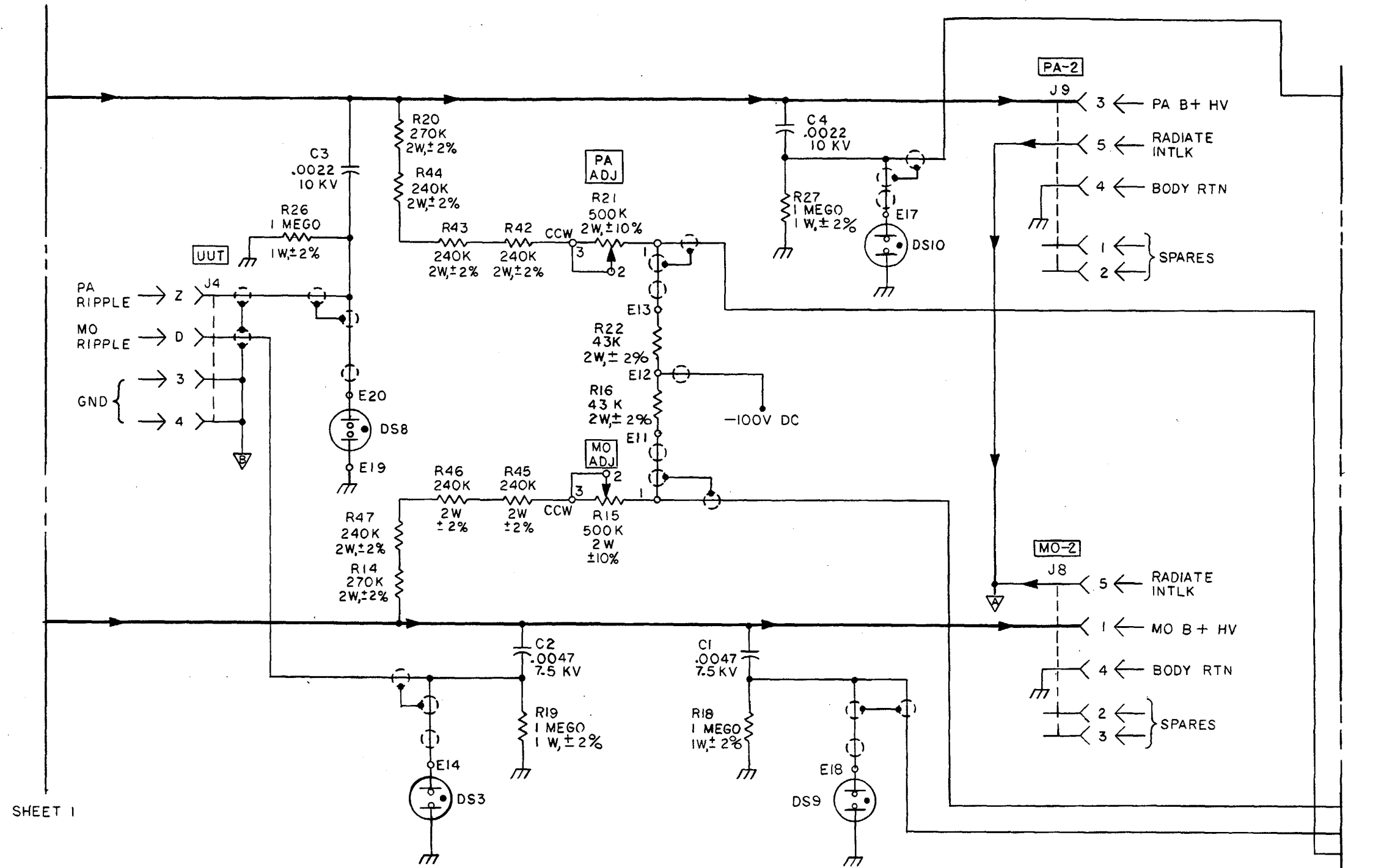

NOTE: REFER TO APPENDIX B FOR SERIAL NUMBER EFFECTIVITY.

SHEET 3

MS 604733A

Figure 3-278. High-voltage regulator test set TF8-1021 11570859 *(AE), *(AV) (see note) (FG 1000) - schematic (sheet 2 of 7).

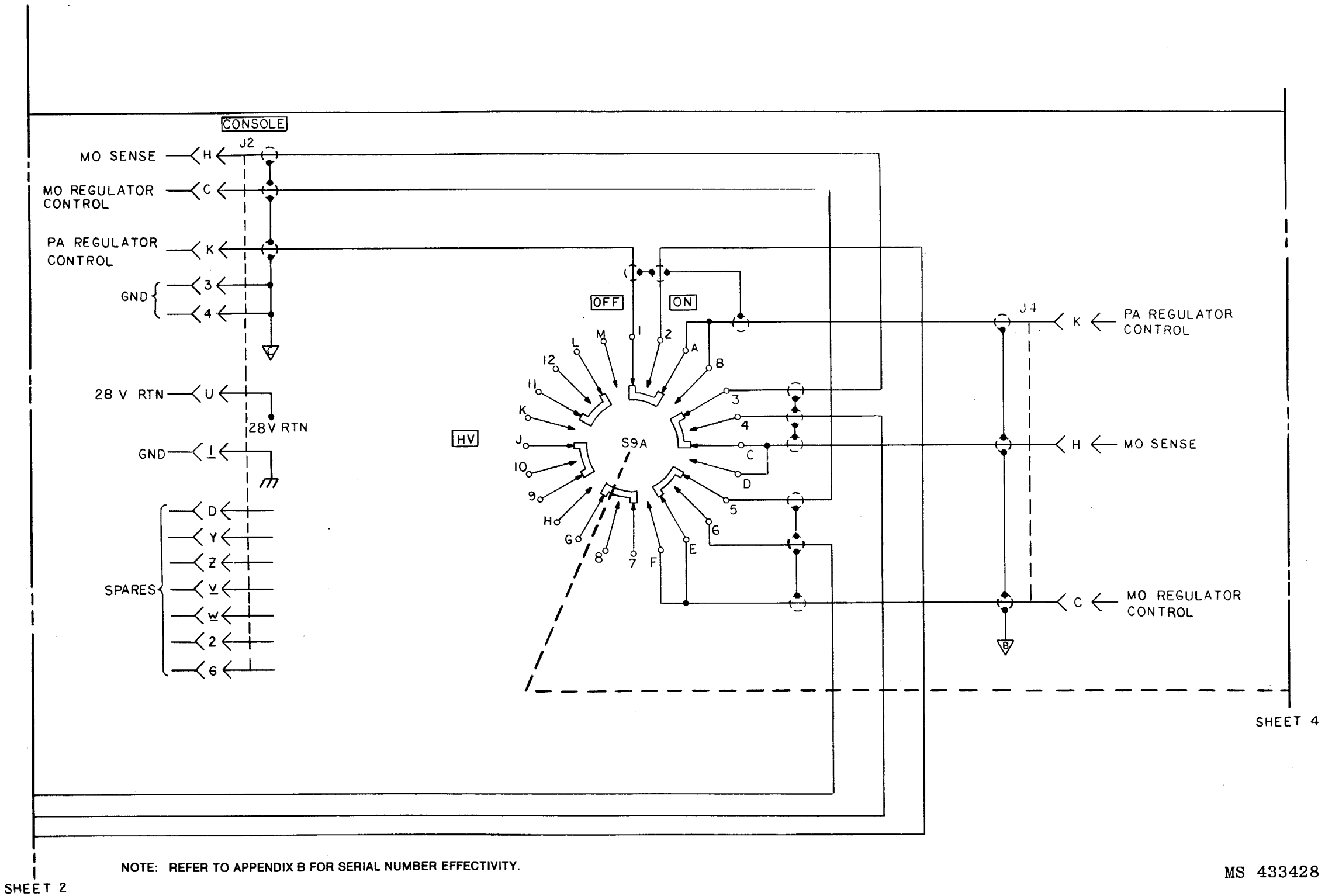
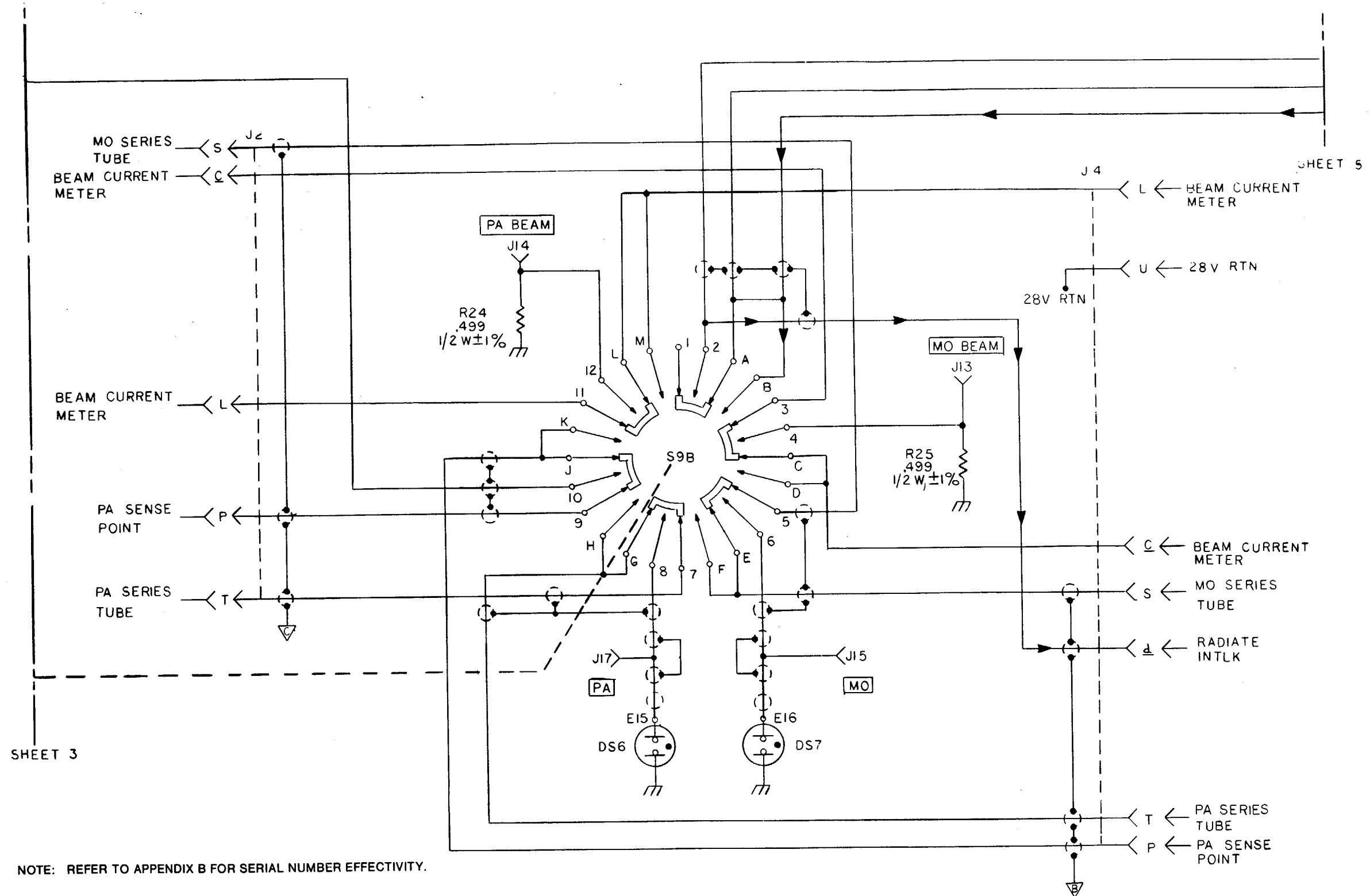

Figure 3-278. High-voltage regulator test set TF8-1021 11570859 *(AE), *(AV) (see note) (FG 1000) - schematic (sheet 3 of 7).



NOTE: REFER TO APPENDIX B FOR SERIAL NUMBER EFFECTIVITY.

MS 433429

Figure 3-278. High-voltage regulator test set TF8-1021 11570859 *(AE), *(AV) (see note) (FG 1000) - schematic (sheet 4 of 7).

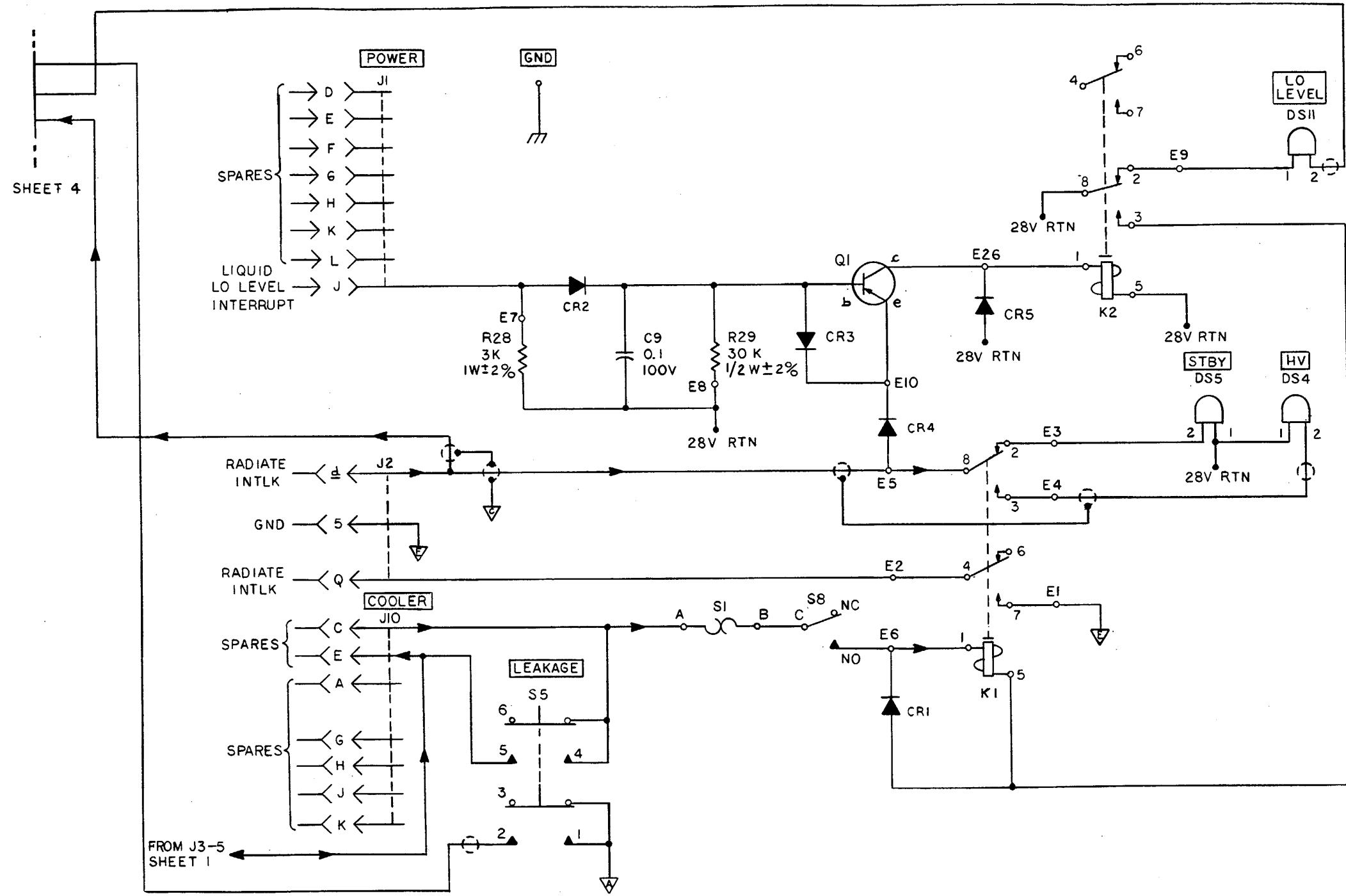

NOTE: REFER TO APPENDIX B FOR SERIAL NUMBER EFFECTIVITY.

MS 433430A

Figure 3-278. High-voltage regulator test set TF8-1021 11570859 *(AE), *(AV) (see note) (FG 1000) - schematic (sheet 5 of 7).

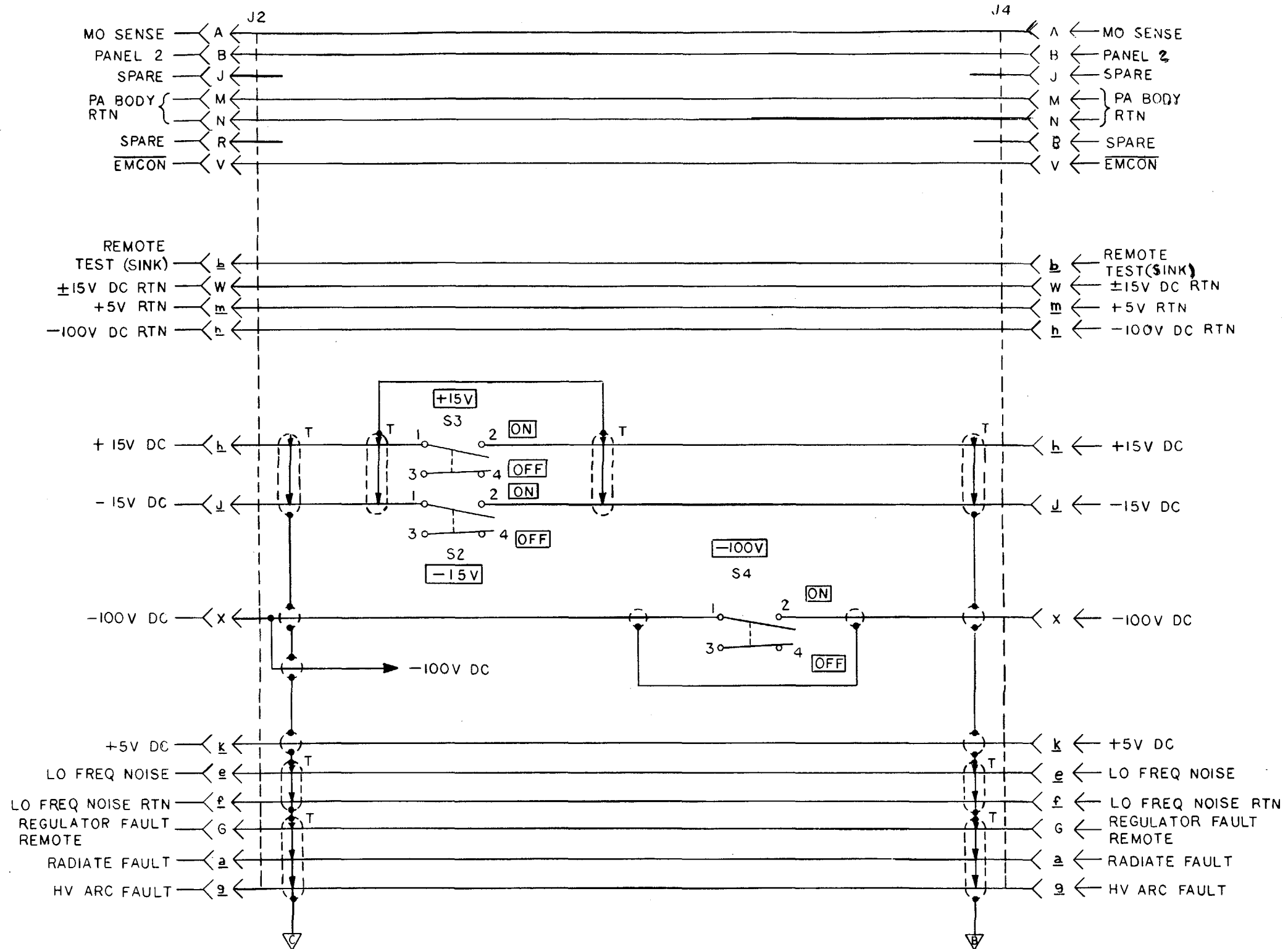

NOTE: REFER TO APPENDIX B FOR SERIAL NUMBER EFFECTIVITY.

MS 433431

Figure 3-278. High-voltage regulator test set TF8-1021 11570859 *(AE) (see note) (FG 1000) - schematic (sheet 6 of 7).

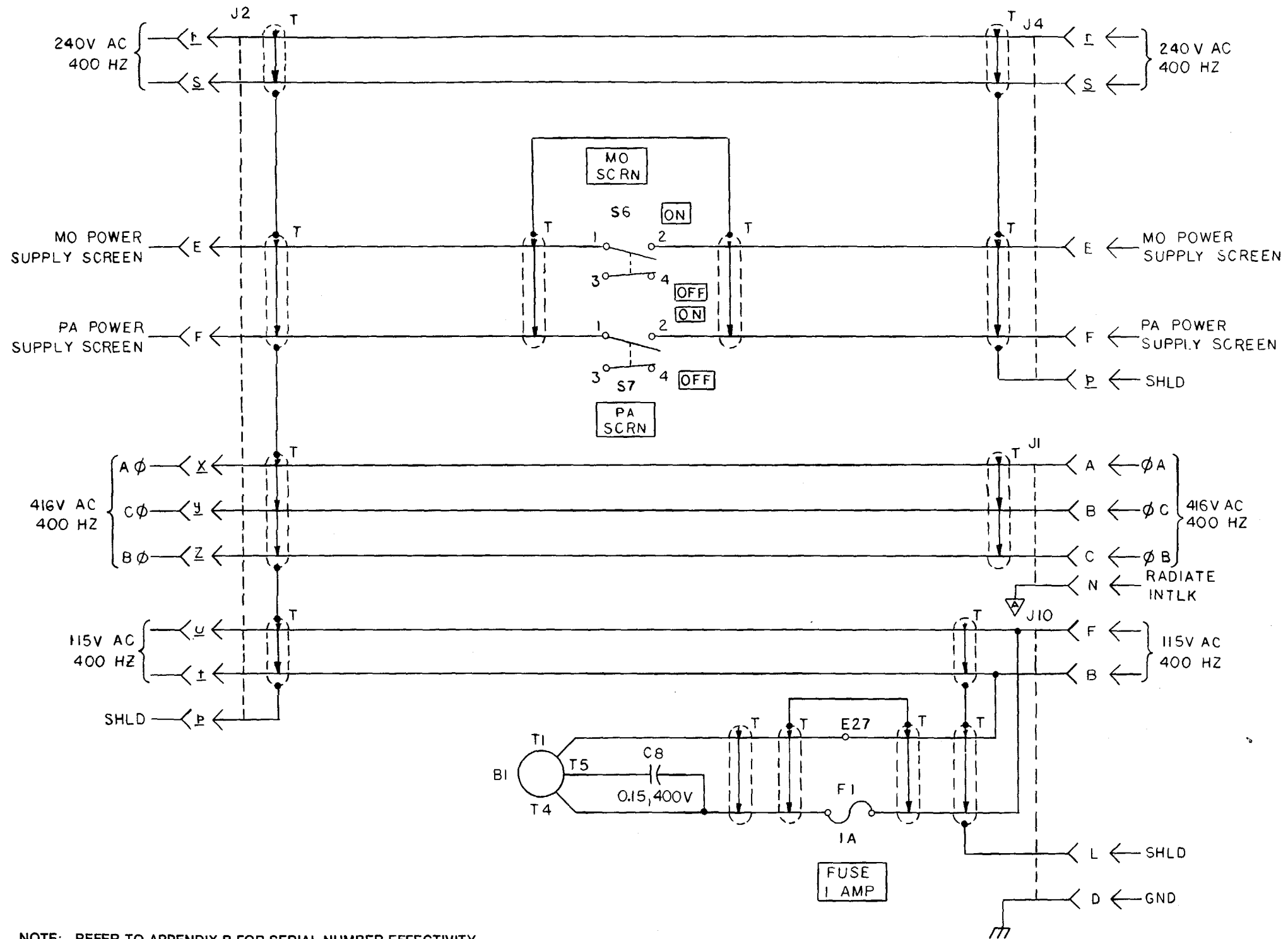

NOTE: REFER TO APPENDIX B FOR SERIAL NUMBER EFFECTIVITY.

MS 433432

Figure 3-278. High-voltage regulator test set TF8-1021 11570859 *(AE) (see note) (FG 1000) - schematic (sheet 7 of 7).

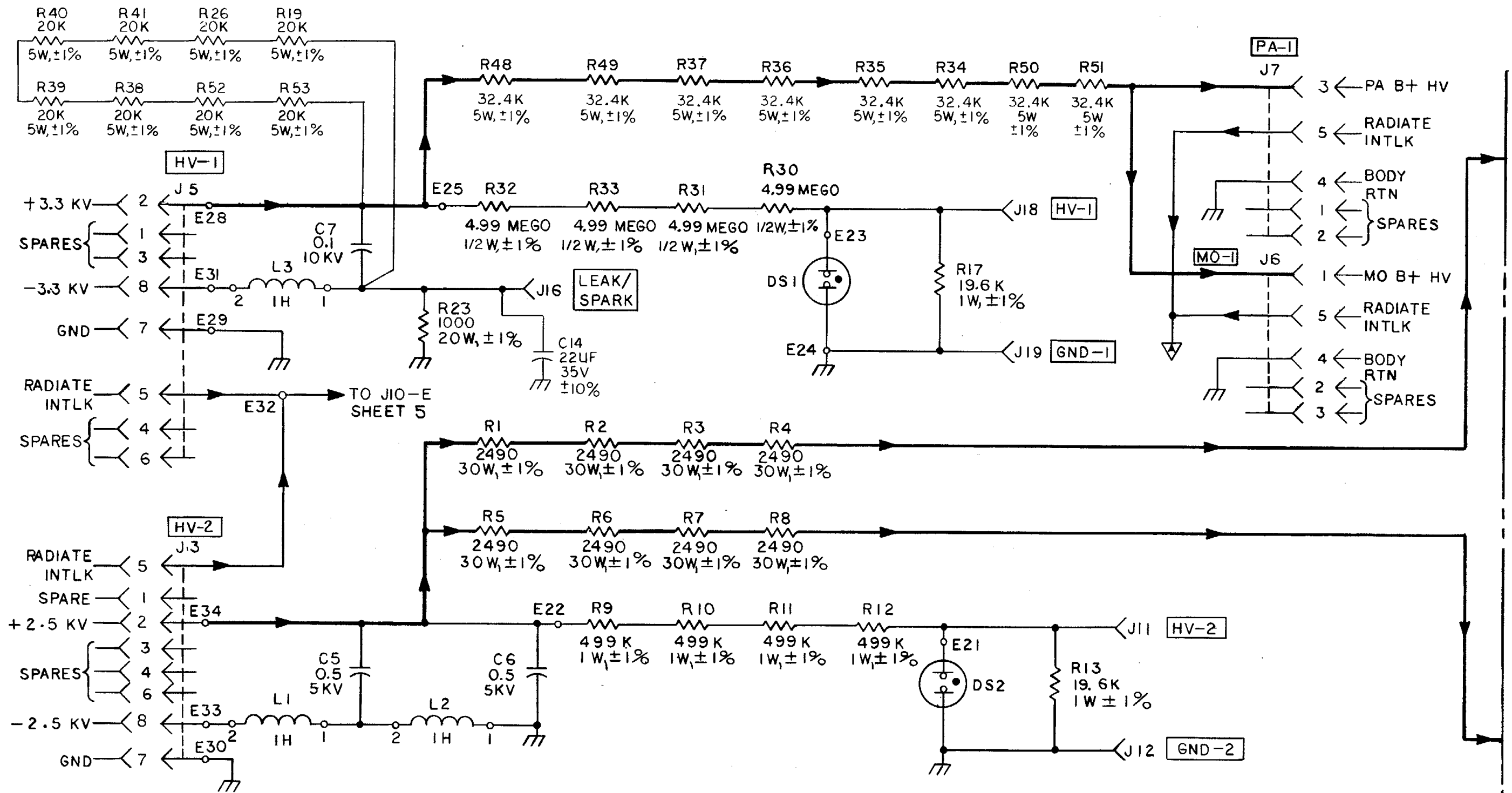

NOTE: REFER TO APPENDIX B FOR SERIAL NUMBER EFFECTIVITY.

SHEET 2

Figure 3-279. High-voltage regulator test set TF8-1021 13234185*(AM) (see note) (FG 1000) - schematic (sheet 1 of 8).

MS 604734A

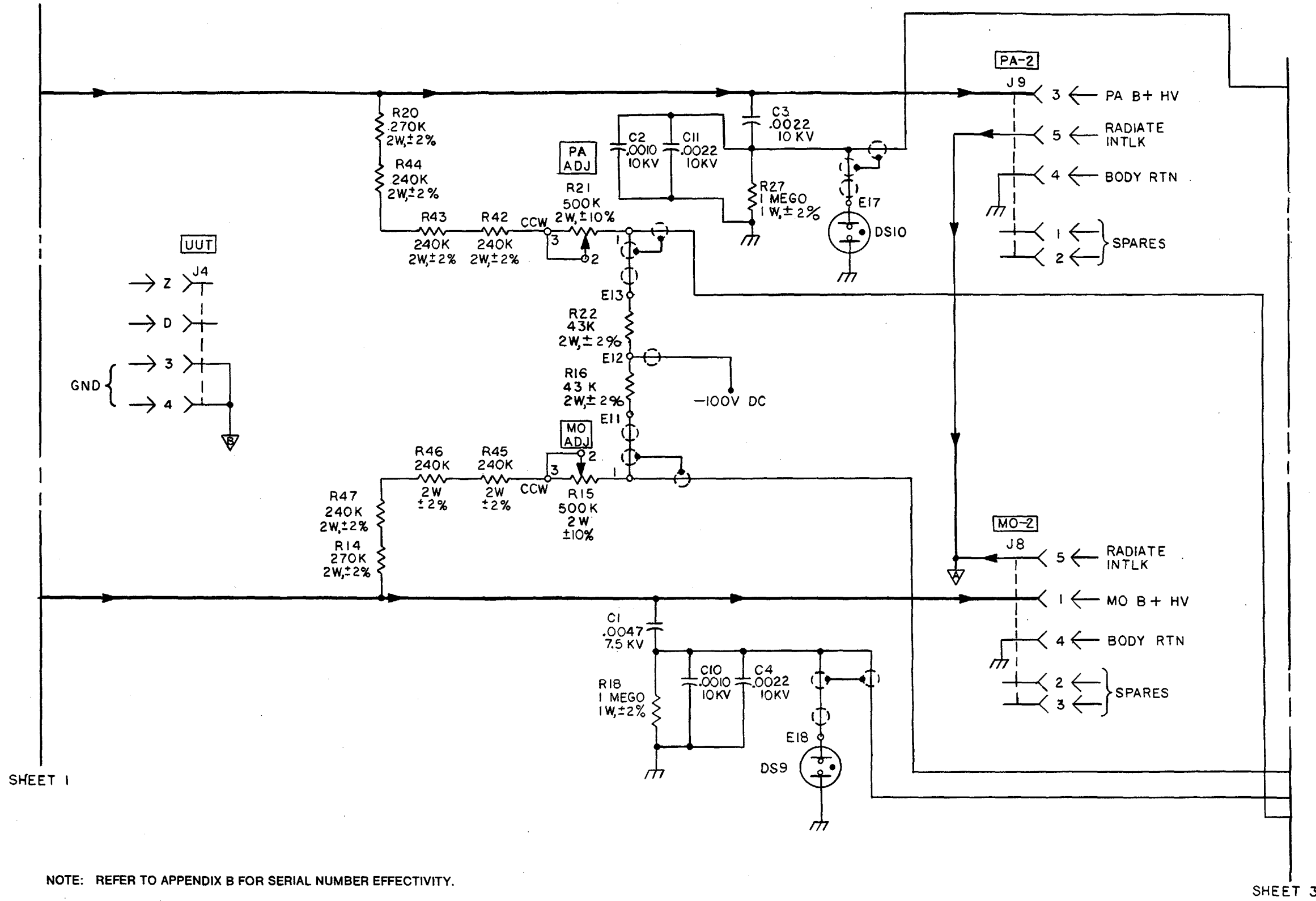

SHEET 1

NOTE: REFER TO APPENDIX B FOR SERIAL NUMBER EFFECTIVITY.

SHEET 3

MS 604734A

Figure 3-279. High-voltage regulator test set TF8-1021 13234185 *(AU), (AV) (see note) (FG 1000) - schematic (sheet 2 of 8).

3-423/(3-424 blank)

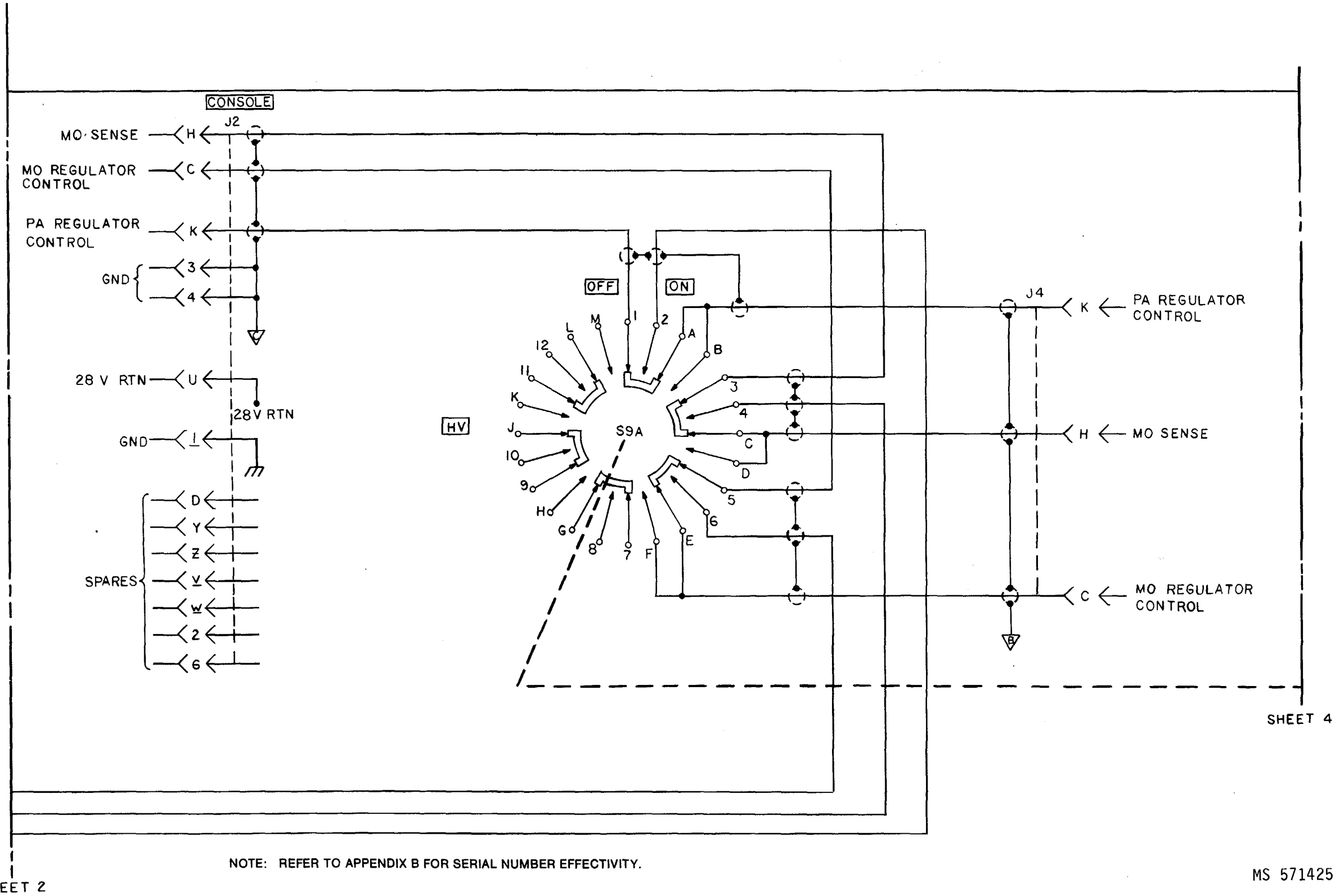
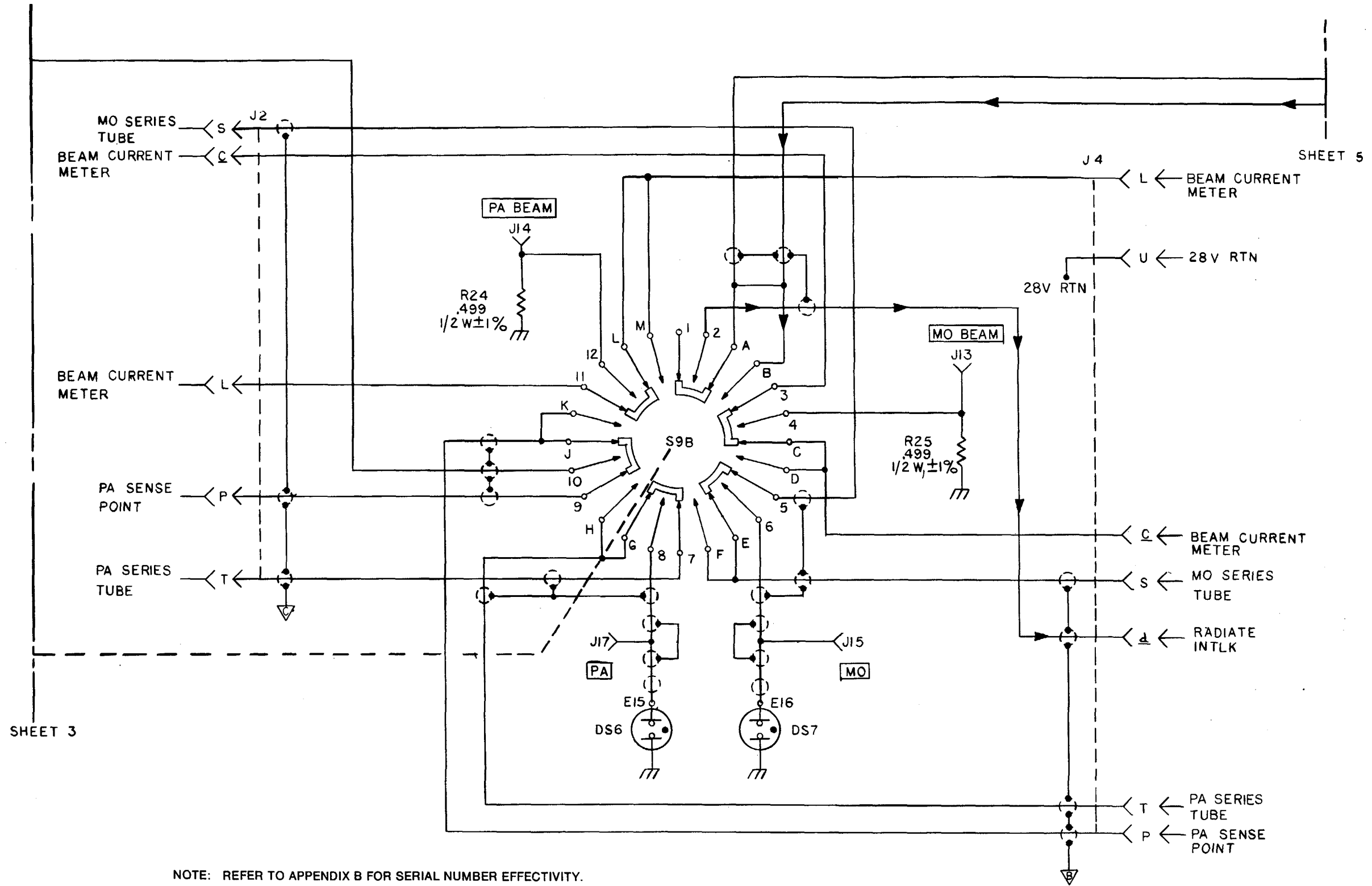

Figure 3-279. High-voltage regulator test set TF8-1021 13234185 *(AM) (see note) (FG 1000) - schematic (sheet 3 of 8).

3-425/(3-426 blank)



NOTE: REFER TO APPENDIX B FOR SERIAL NUMBER EFFECTIVITY.

MS 571426

Figure 3-279. High-voltage regulator test set TF8-1021 13234185*(AM) (see note) (FG 1000) - schematic (sheet 4 of 8).

3-427/(3-428 blank)

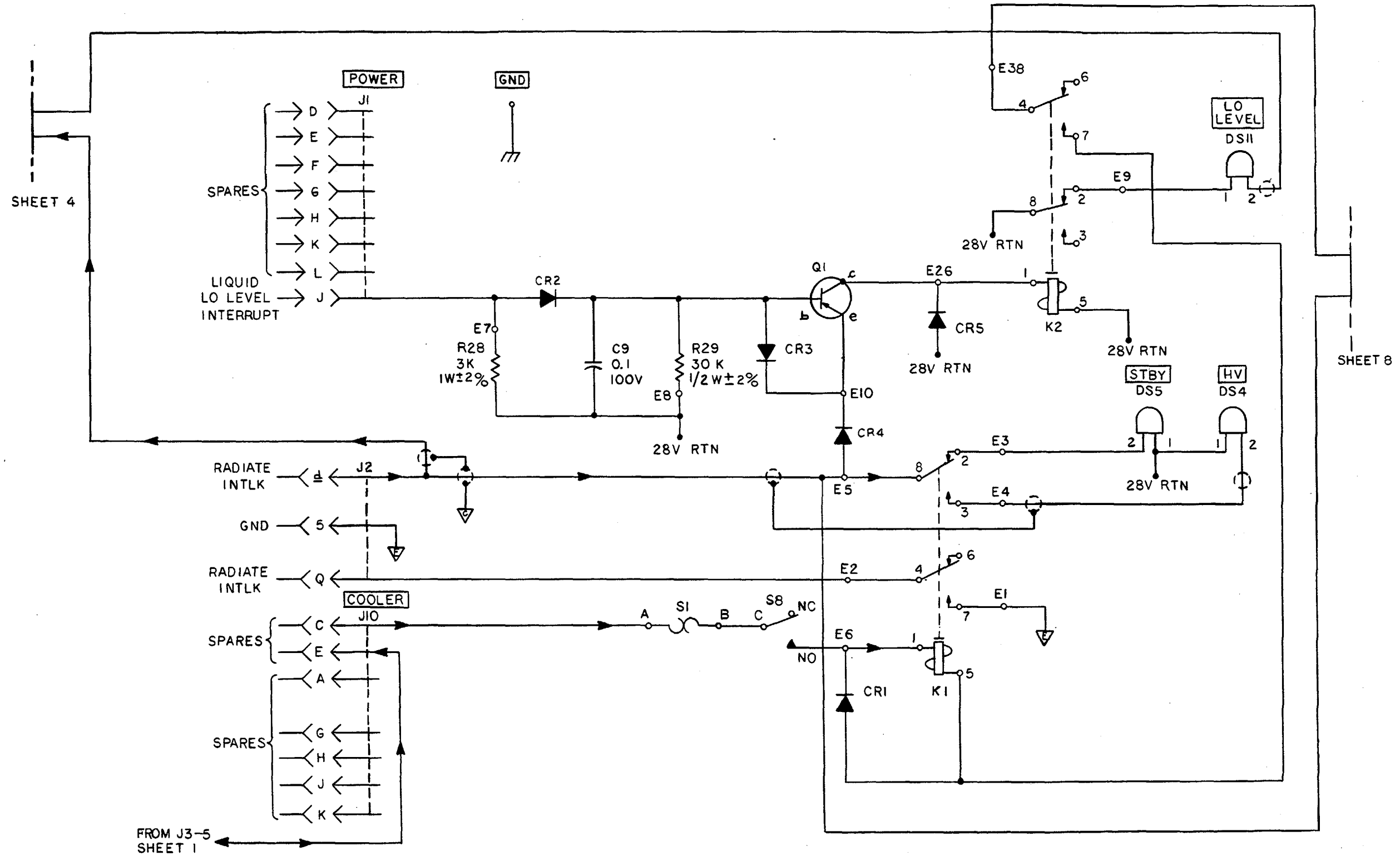

NOTE: REFER TO APPENDIX B FOR SERIAL NUMBER EFFECTIVITY.

MS 571427A

Figure 3-279. High-voltage regulator test set TF8-1021 13234185 *(AM), *(AV) (see note) (FG 1000) - schematic (sheet 5 of 8).

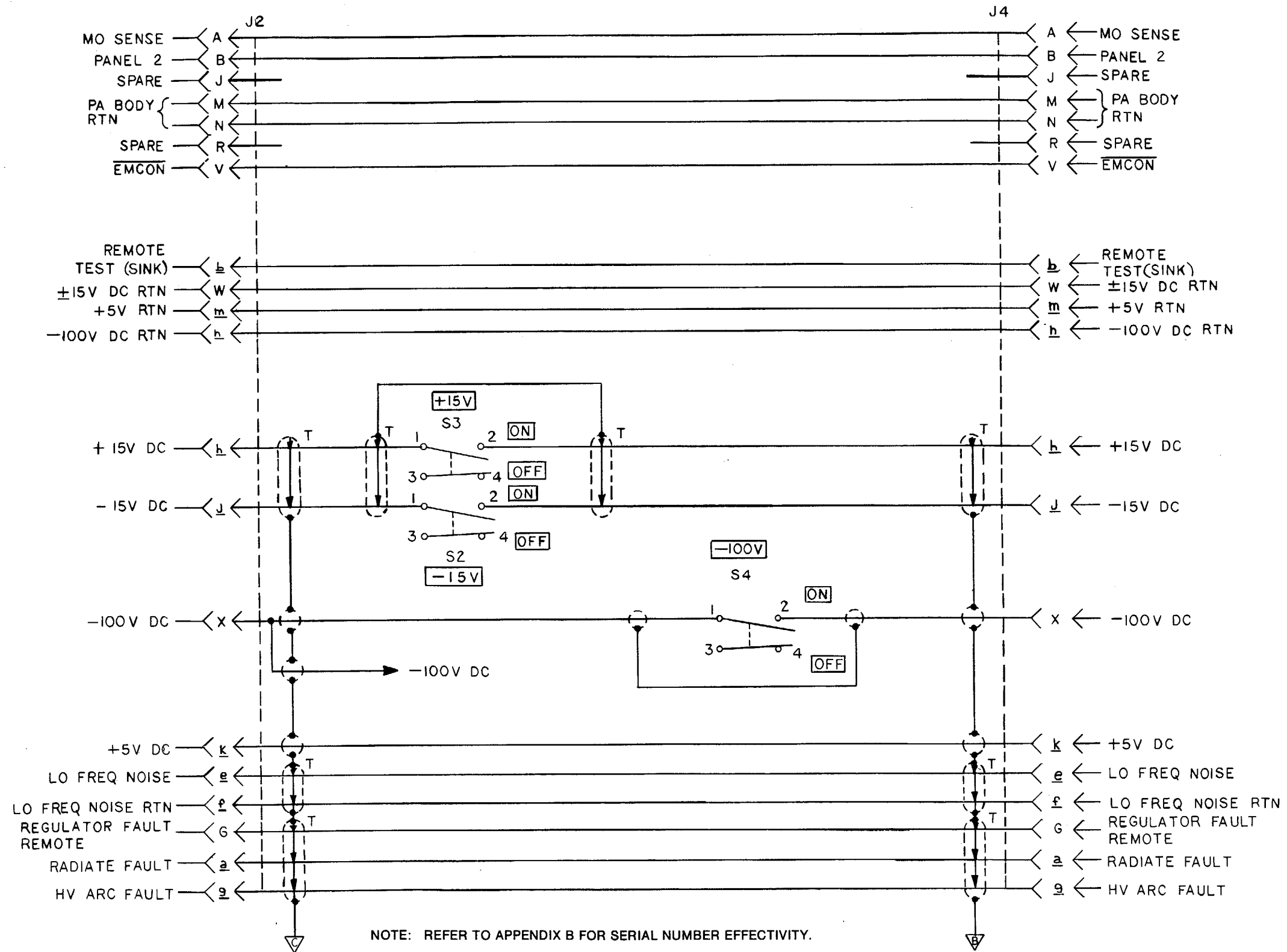

MS 571428

Figure 3-279. High-voltage regulator test set TF8-1021 13234185 *(AM) (see note) (FG 1000) - schematic (sheet 6 of 8).

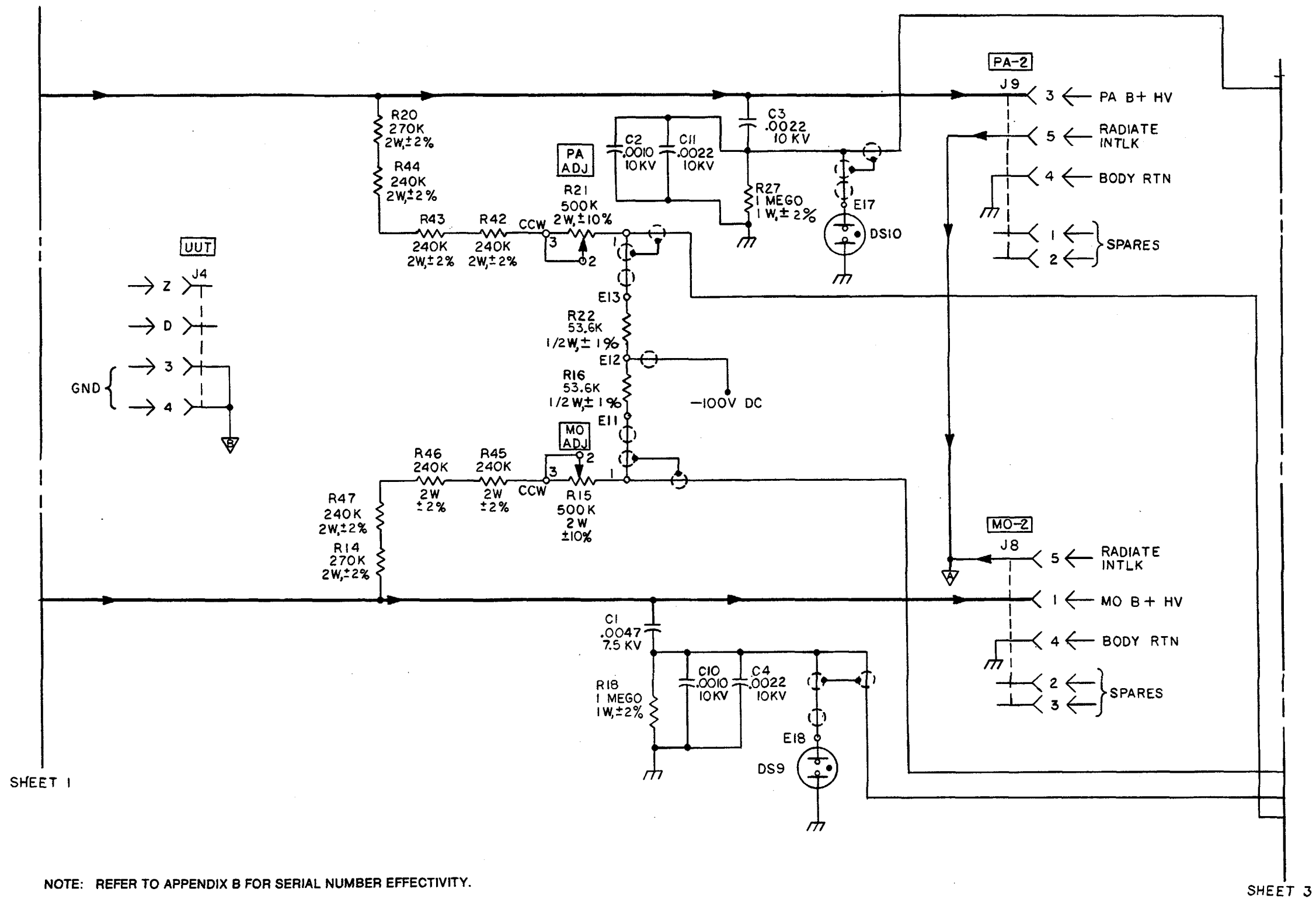

NOTE: REFER TO APPENDIX B FOR SERIAL NUMBER EFFECTIVITY.

MS 605249

Figure 3-279.1. High-voltage regulator test set 13384971 *(AW) (see note) (FG 1000)-schematic (sheet 2 of 8)

3-436.1 (3-436.2 blank)

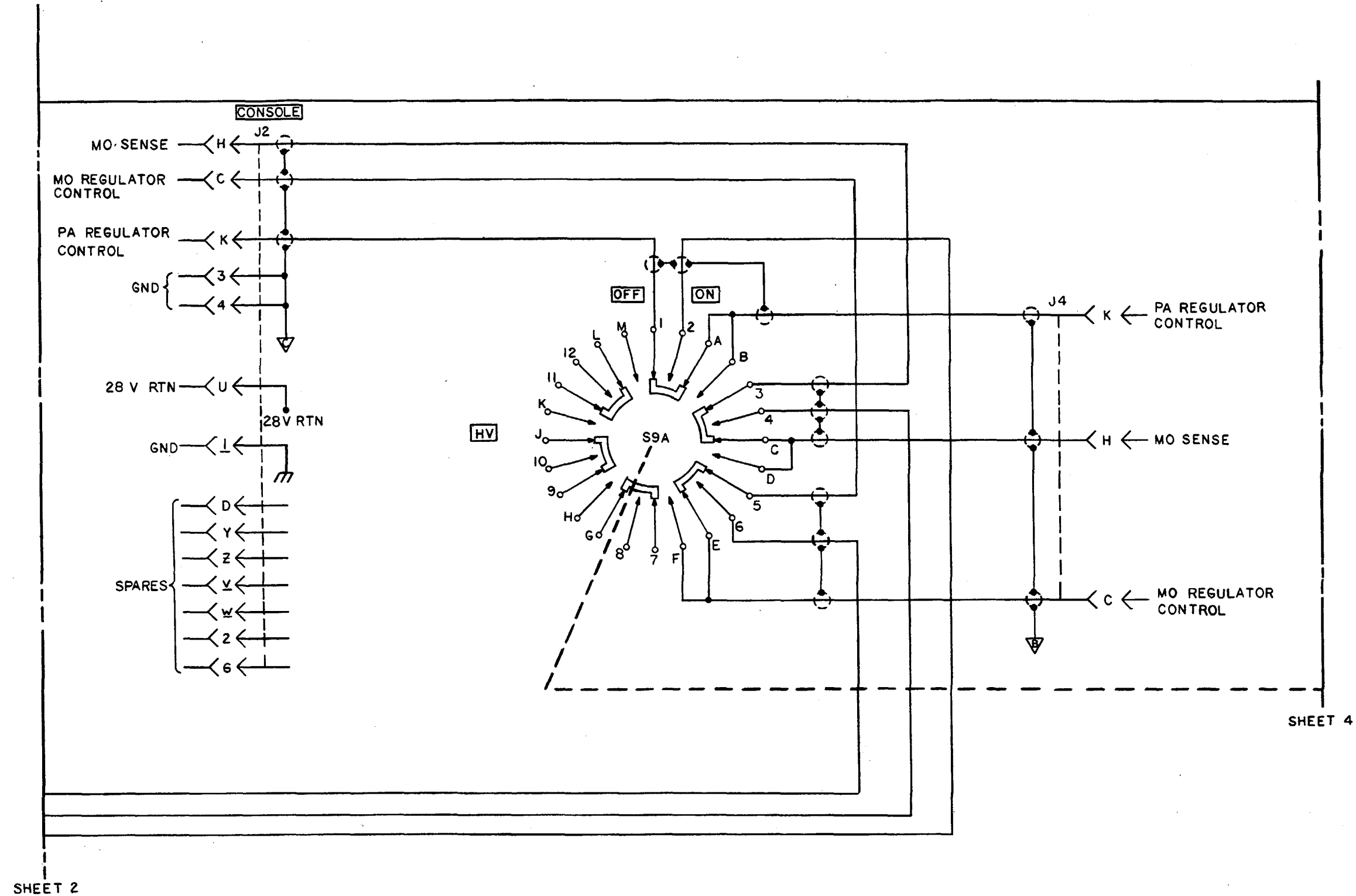

NOTE: REFER TO APPENDIX B FOR SERIAL NUMBER EFFECTIVITY.

MS 605250

Figure 3-279.1. High-voltage regulator test set 13384971 *(AW) (see note) (FG 1000)-schematic (sheet 3 of 8)

3-436.3 (3-436.4 blank)

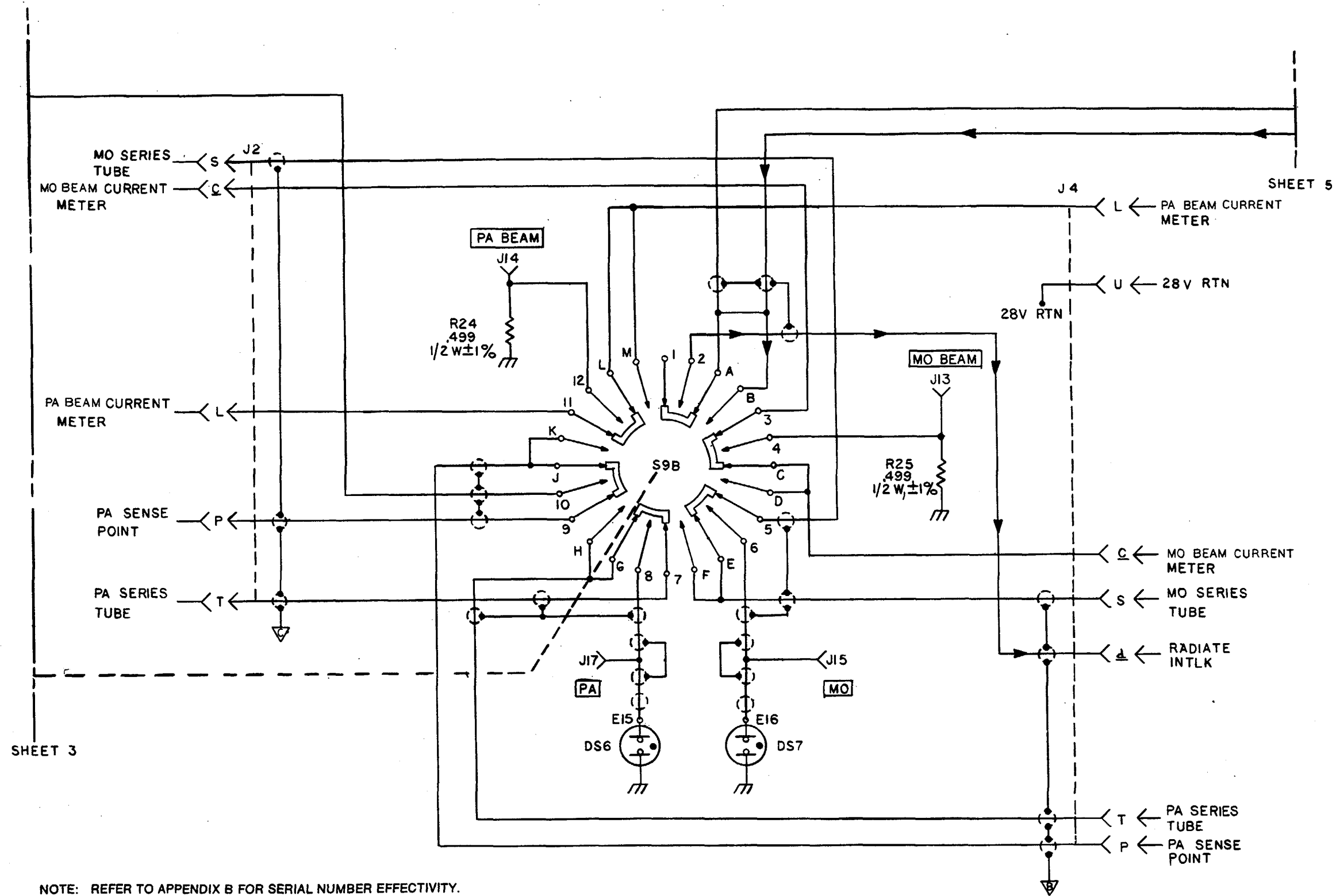

NOTE: REFER TO APPENDIX B FOR SERIAL NUMBER EFFECTIVITY.

MS 605251

Figure 3-279.1. High-voltage regulator test set 13384971 *(AW) (see note) (FG 1000)-schematic (sheet 4 of 8)

3-436.5 (3-436.6 blank)

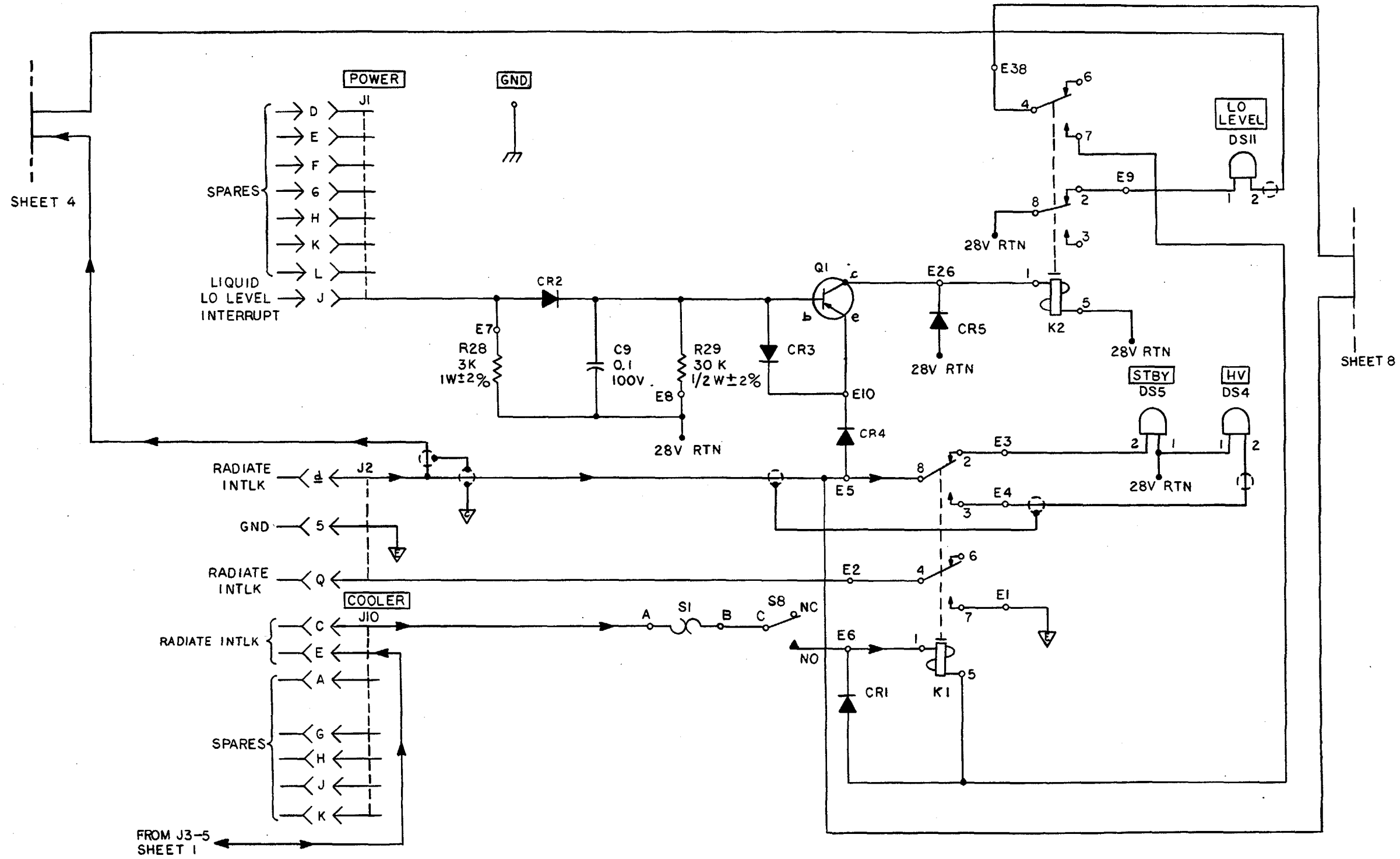

NOTE: REFER TO APPENDIX B FOR SERIAL NUMBER EFFECTIVITY.

MS 605252

Figure 3-279.1. High-voltage regulator test set 13384971 *(AW) (see note) (FG 1000)-schematic (sheet 5 of 8)

3-436.7 (3-436.8 blank)

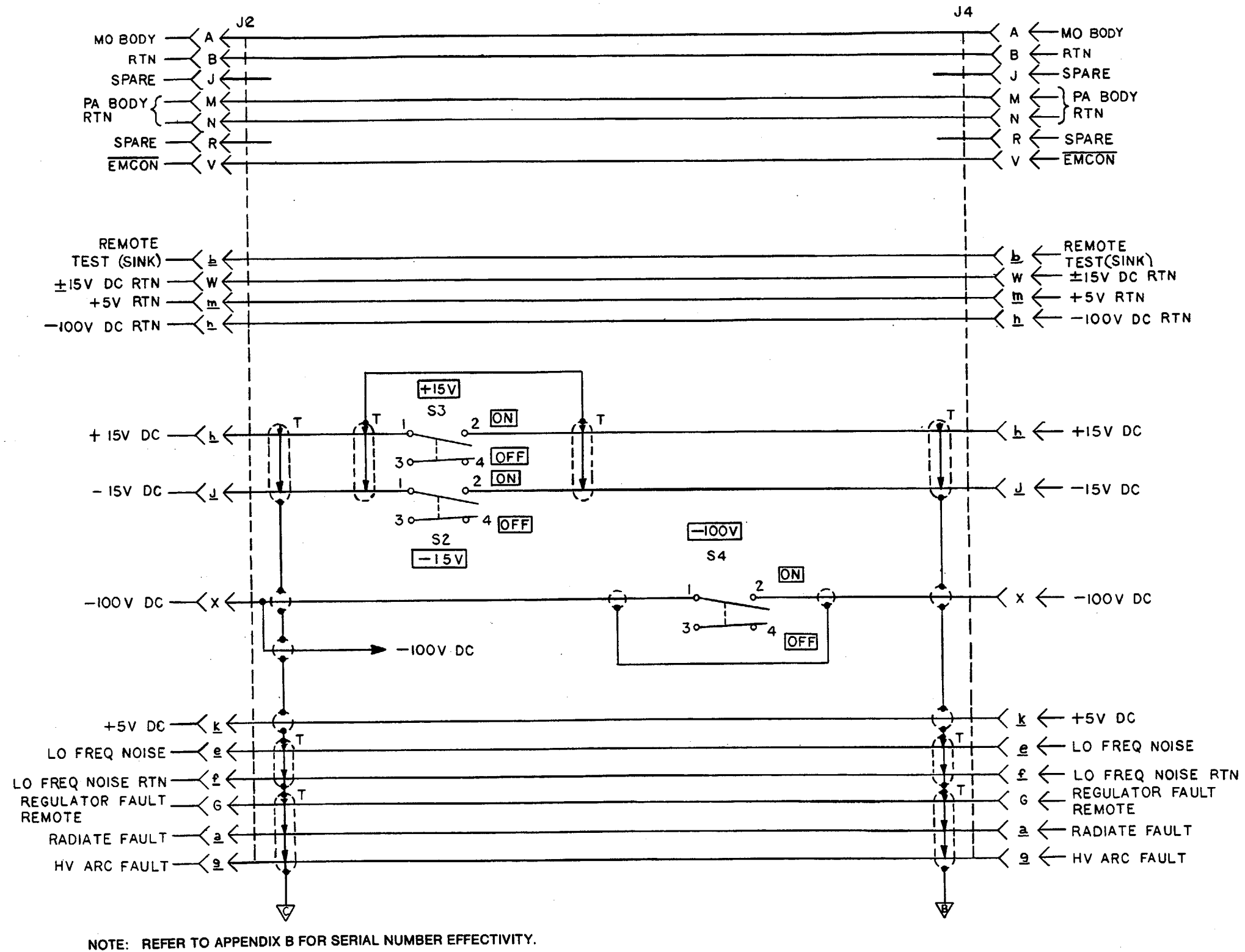

MS 605253

Figure 3-279.1. High-voltage regulator test set 13384971 *(AW) (see note) (FG 1000)-schematic (sheet 6 of 8)

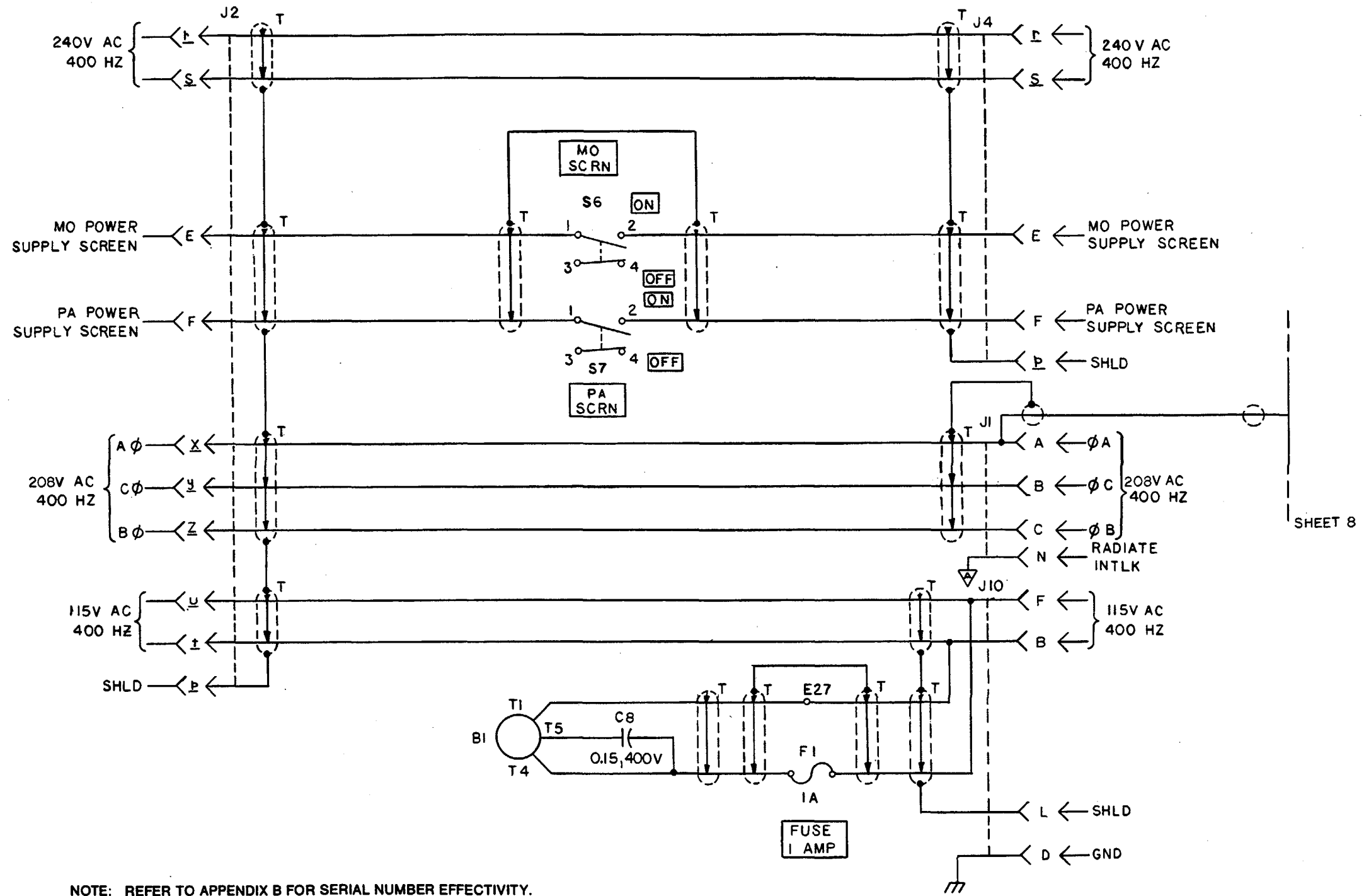
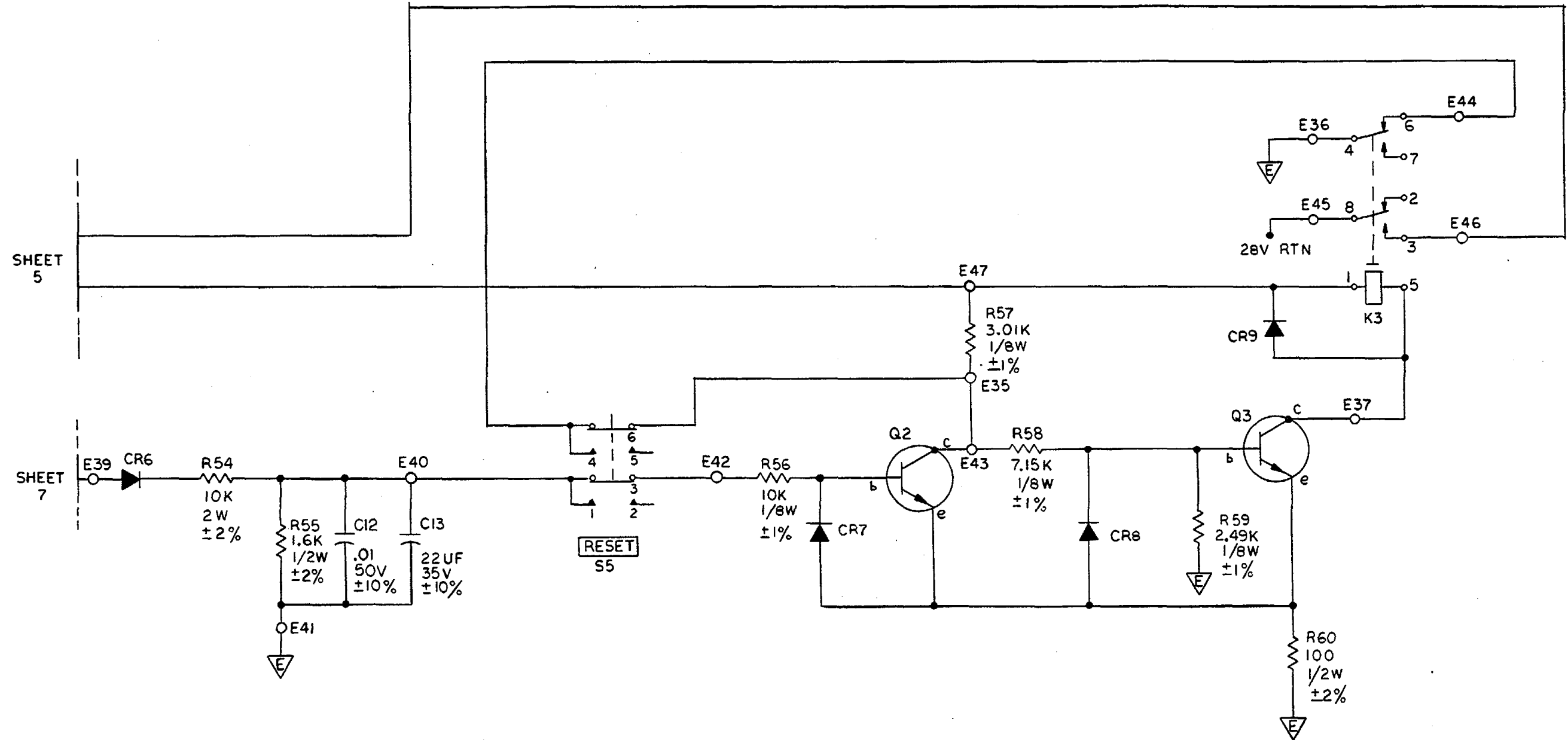

Figure 3-279.1. High-voltage regulator test set 13384971 *(AW) (see note) (FG 1000)-schematic (sheet 7 of 8)

3-436.11 (3-436.12 blank)

MS 605254



NOTE: REFER TO APPENDIX B FOR SERIAL NUMBER EFFECTIVITY.

MS 605255

Figure 3-279.1. High-voltage regulator test set 13384971 *(AW) (see note) (FG 1000)-schematic (sheet 8 of 8)

Section VIII. HIGH-VOLTAGE POWER SUPPLY TEST SET TF-1022

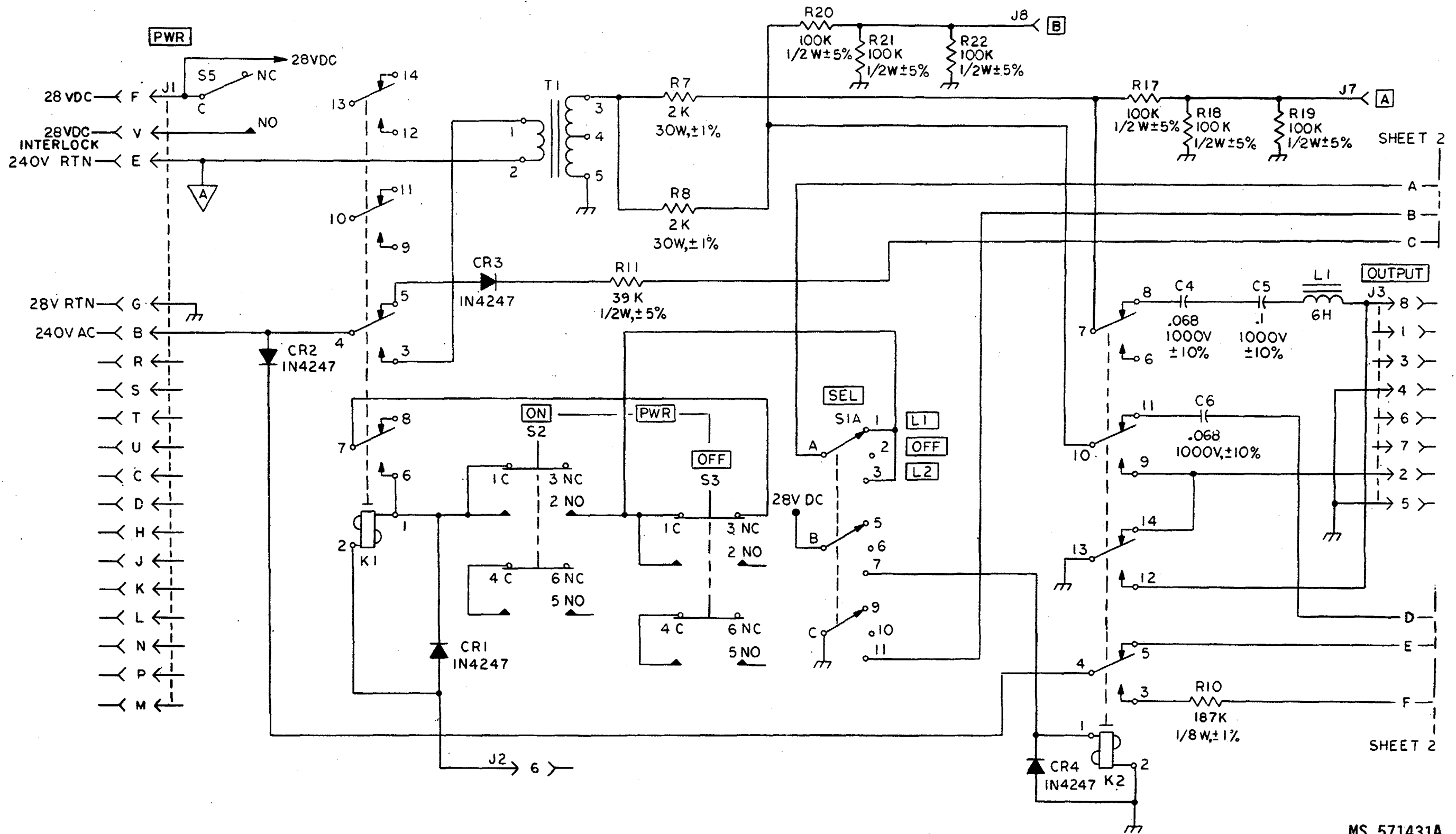
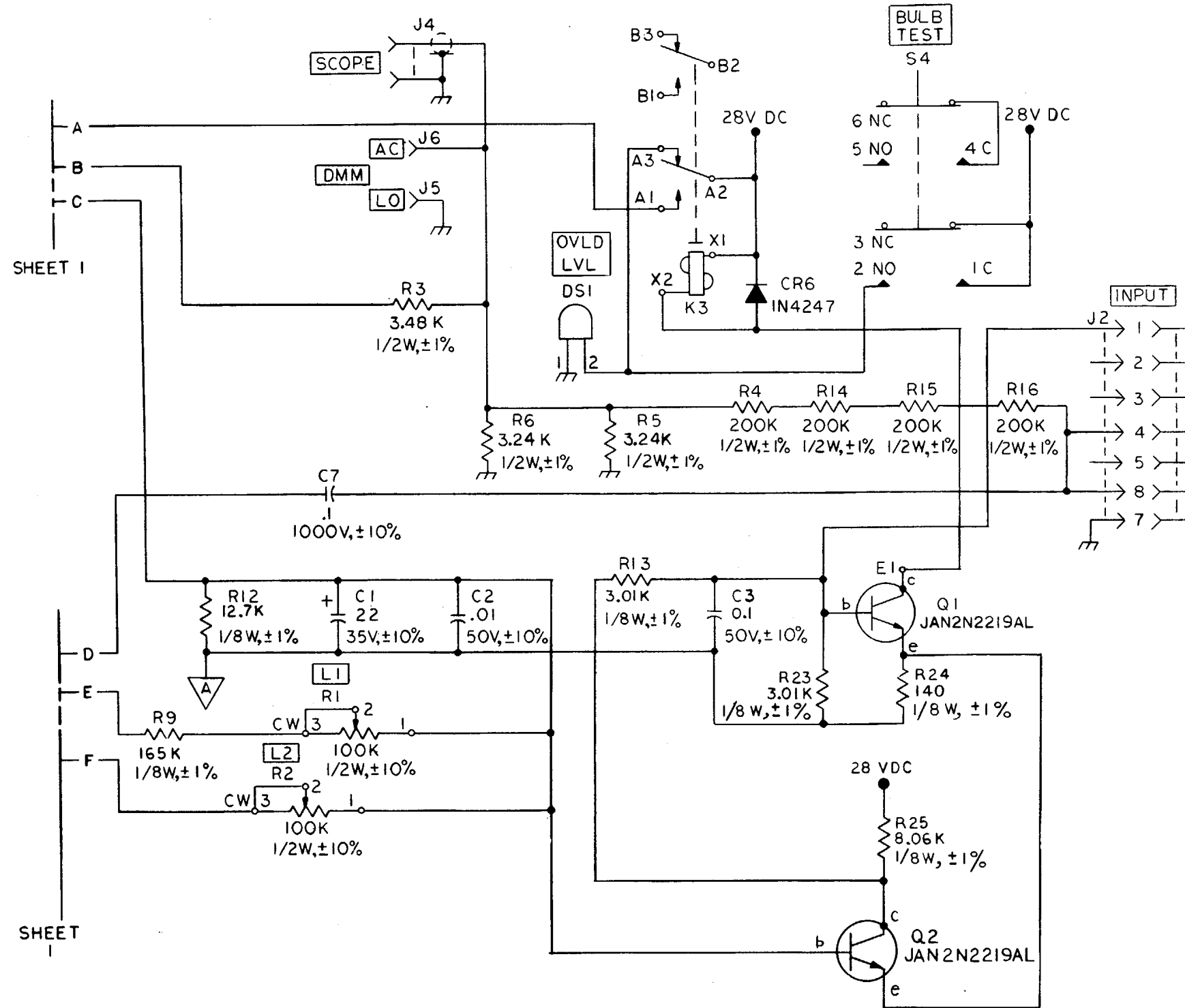

Figure 3-280. High-voltage power supply test set TF8-1022 13234179 (FG 1200)-schematic (sheet 1 of 2).



MS 571432A

Figure 3-280. High-voltage power supply test set TF8-1022 13234179 (FG 1200)-schematic (sheet 2 of 2).

APPENDIX A
REFERENCES

Refer to TM 9-1425-525-L for a list of other publications pertinent to this material and associated equipment.

APPENDIX B
SERIAL NUMBER EFFECTIVITY CODE

B-1. General

The serial number effectivity code is an alphabetical code used to indicate differences among models.

B-2. Symbols Used

Alphabetical symbols are used in the code. The symbol represents the serialization of the major assembly. An asterisk preceding the symbol indicates that the serialization is not of the major assembly, but instead is of the major item in which the assembly is normally located.

B-3. Symbols Not Used

To avoid possible confusion with classification markings, numerals, and certain units of equipment, the symbols (A), (B), (C), (I), (O), (S), and (U) are not used.

B-4. Serial Number Effectivity Code

The following is a list of the code symbols used in this manual.

- * (D) 275001 through 300000.
- * (E) 300001 and up.
- * (F) 300001 and up.
- * (G) 275001 through 275011.
- * (H) Replaced by *(J) on an exhaust of spares basis in shops 275001 through 380000.
- * (J) 380001 and up.
- * (K) 275001 through 520335. Replaced by *(L) on an exhaust of spares.
- * (L) 520336 and up.
- * (M) 275001 through 500236.
- * (N) 500237 and up.
- * (P) 275001 through 390000, provided that MWO 9-4900-525-50-13 has not been applied, and 390001 and up.
- * (Q) 275001 through 390000, provided that MWO 9-4900-525-50-13 has been applied, and 390001 and up.

- * (R) 275001 through 500237 provided that MWO 9-4935-545-50-1 has not been applied.
- * (T) 275001 through 500237 provided that MWO 9-4935-545-50-1 has been applied, and 520336 and up.
- * (V) Shop 2 serial numbers 275001 through 540156; shop 3 serial numbers 275001 through 540156; MT shop serial numbers 275001 through 520347 provided MWO 9-4900-525-50-28 has been applied and 550413 and up.
- * (W) 275001 through 540156.
- * (X) Shop 1 serial numbers 275001 through 540156; shop 9 serial numbers 300001 through 400001; TAG serial numbers 275001 through 520340 provided MWO 9-4900-1525-50-4 has not been applied.
- * (Y) Shop 1 serial numbers 275001 through 540156; shop 9 serial number 300001 through 400001; TAG serial numbers 275001 through 520340 provided MWO 9-4900-1525-50-4 has been applied and 550413 and up.
- * (Z) Shop 1 serial numbers 275001 through 560309; shop 9 serial numbers 300001 through 400001 provided MWO 9-4935-1544-50-2 has not been applied.
- * (AA) Shop 1 serial numbers 275001 through 590345; shop 9 serial numbers 300001 through 570119 provided MWO 9-4935-1544-50-2 has been applied and provided MWO 9-4900-1525-50-6 has not been applied.
- * (AB) Shop 1 serial numbers 275001 through 630451; shop 9 serial numbers 300001 through 630451; and TAG serial numbers 275001 through 630451 provided MWO 9-4900-1525-50-5 has not been applied.
- * (AC) Shop 1 serial numbers 275001 through 630451; shop 9 serial numbers 300001 through 630451; and TAG serial numbers 275001 through 630451 provided MWO 9-4900-1525-50-5 has been applied and 630452 and up.
- * (AD) Shop 2 serial numbers 275001 through 630451 provided MWO 9-4935-1545-50-1 has not been applied.

- * (AE) Shop 2 serial numbers 275001 through 630451 provided MWO 9-4935-1545-50-1 has been applied and 630452 and up, and provided MWO 9-4935-1545-50-2 has not been applied.
- * (AF) Shop 1 serial numbers 275001 through 590345; and shop 9 serial numbers 300001 through 570119 provided MWO 9-4900-1525-50-6 has been applied and 610121 and up.
- * (AG) Shop 1 serial numbers 275001 through 590345; shop 9 serial numbers 300001 through 430115; and TAG serial numbers 275001 through 580443 provided MWO 9-4900-1525-50-9 has not been applied.
- * (AH) Deleted.
- * (AJ) Deleted.
- * (AK) Shop 1 serial numbers 275001 through 590345; shop 9 serial numbers 300001 through 570119; and TAG serial numbers 275001 through 580443 provided MWO 9-4900-1525-50--8 has not been applied.
- * (AL) Shop 1 serial numbers 275001 through 590345; shop 9 serial numbers 300001 through 570119; and TAG serial numbers 275001 through 580443 provided MWO 9-4900-1525-50-8 has been applied and 640143 and up.
- * (AM) Shop 2 serial numbers 275001 through 570119 provided MWO 9-4935-1545-50-2 has been applied and 730189 and up, and provided MWO 9-4935-2545-50-5 has not been applied.
- * (AN) 257001 through 680220.
- * (AO) 680221 and up.
- * (AP) Shop 1 serial numbers 275001 through 540156; shop 9 serial numbers 300001 through 400001; and TAG serial numbers 275001 through 520340 provided MWO 9-4900-2525-50-1 has not been applied.

- * (AQ) Shop 1 serial numbers 275001 through 540156; shop 9 serial numbers 300001 through 400001; and TAG serial numbers 275001 through 520340 provided MWO 9-4900-2525-50-1 has been applied and 680221 and up.
- * (AR) Shop 1 serial numbers 275001 through 540156; shop 9 serial numbers 300001 through 400001; and TAG serial numbers 275001 through 520340 provided MWO 9-4900-1525-50-11 has not been applied.
- * (AS) Shop 1 serial numbers 275001 through 540156; shop 9 serial numbers 300001 through 400001; and TAG serial numbers 275001 through 520340 provided MWO 9-4900-1525-50-11 has been applied and 730189 and up.
- * (AT) Shop 2 serial numbers 275001 through 540156 provided MWO 94935-1545503 has not been applied.
- * (AU) Shop 2 serial numbers 275001 through 540156 provided MWO 9-4935-1545-50-3 has been applied and 730189 and up, and provided MWO 9-4935-2545-50-5 has not been applied.
- * (AV) Shop 1 serial numbers 165003 through 590345; shop 2 serial numbers 275001 through 570119; shop 9 serial numbers 300001 through 660351; and TAG serial numbers 275001 through 670001 provided MWO 9-4900-2525-50-5 has not been applied.
- * (AW) Shop 1 serial numbers 165003 through 590345; shop 2 serial numbers 275001 through 570119; shop 9 serial numbers 300001 through 660351 and TAG serial numbers 275001 through 670001 provided MWO 9-4935-1545-50-3 and MWO 9-4900-2525-50-5 have been applied and 790075 and up.

APPENDIX C SCHEMATIC SYMBOLS

GENERAL AND MISC.

ADJUSTABLE: CONTINUOUSLY VARIABLE FOR RESISTORS, CAPACITORS, ETC.

OR
SLIDING CONTACT

SCREWDRIVER ADJUSTMENT

KNOB ADJUSTMENT

BUILD UP FOR VARIABLE RESISTORS (WHEN THE SHAFT IS ROTATED IN A CLOCKWISE DIRECTION THE WIPER WILL MOVE IN THE DIRECTION OF THE ARROW)

SHIELDING AND MECHANICAL LINKAGE

ALL UNITS

MAJOR ITEM

MINOR SIGNAL

MAJOR SIGNAL
ARROW INDICATES DIRECTION OF SIGNAL FLOW

STRAIGHT THRU CHASSIS (NO CONNECTION)

TUBE STAGE AND GENERAL APPARATUS

AMPLIFIER

DIRECTLY CONNECTED TO A GROUND BUS
CHASSIS SYSTEM GROUNDS

SWITCHES AND RELAYS

SPST

SPDT

PUSHBUTTON NO

PUSHBUTTON NC

SWITCH BREAKER

PUSH-PULL BREAKER

PUSH BREAKER

INTERLOCK

THERMAL SWITCH

SLIDE SWITCH

WAFER SWITCH

INDICATES KNOB POSITION

MULTI-CONTACT WAFER SWITCH

SWITCHES AND RELAYS (CONT)

ROTARY (BREAK BEFORE MAKE) (MAKE BEFORE BREAK)

RELAY (DEENERGIZED)

CONTACTOR RELAY (DEENERGIZED)

FUSE

INDICATING AND ILLUMINATING DEVICES

INDICATOR PILOT LAMP (LETTER INDICATES COLOR)

ILLUMINATING LAMP

AC NEON LAMP

DC NEON LAMP

PHOSPHORESCENT LAMP

DOUBLE-POLE INDEPENDENT THROW

INDICATING AND ILLUMINATING DEVICES (CONT)

METER REFERENCE DESIGNATOR INSIDE

HEADSET

HANDSET

MICROPHONE

SPEAKER

CIRCUIT PARTS

RESISTOR

BALLAST LAMP

THERMISTOR

CAPACITOR

FEED THROUGH CAPACITOR

VARIABLE DIFFERENTIAL CAPACITOR

COIL

CHOKE

AIR CORE (ADDITIONAL WINDINGS USED AS NECESSARY)

CIRCUIT PARTS (CONT)

IRON CORE

MAGNETIC CORE WITH ELECTROSTATIC SHIELD

POWDERED IRON CORE

3Ø DELTA TO WYE

SATURABLE REACTOR

CONNECTORS

FEMALE FEED THROUGH ADAPTER

MALE FEMALE

INTERNAL STANDOFF

COAXIAL CONNECTORS MALE-FEMALE

COAXIAL PLUG TO SINGLE CONDUCTOR

CONNECTORS (CONT)

SINGLE TERMINAL

SHIELDED TERMINAL

TEST JACK

INTERNAL TEST POINT

FEMALE CONVENIENCE OUTLET (POLARIZED)

PART OF P1 PART OF J1

PORTION OF PLUG AND JACK

TB

TERMINAL BOARD

CONDUCTORS

SINGLE CONDUCTOR

SHIELDED CONDUCTOR

SHIELDED DOUBLE WIRE

COMMON SHIELD (SEPARATED FOR CONVENIENCE)

CS

TWISTED TRIPLE

CONDUCTORS (CONT)

MULTICONDUCTOR CABLE

CROSSING NOT CONNECTED

JUNCTION

FB

FERRITE BEAD

TUBES, CRYSTALS, TRANSISTORS, ETC.

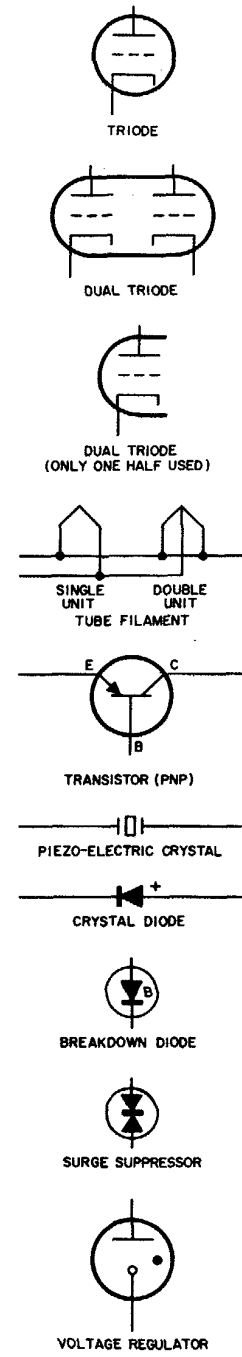

TUBES, CRYSTALS, TRANSISTORS, ETC. (CONT)

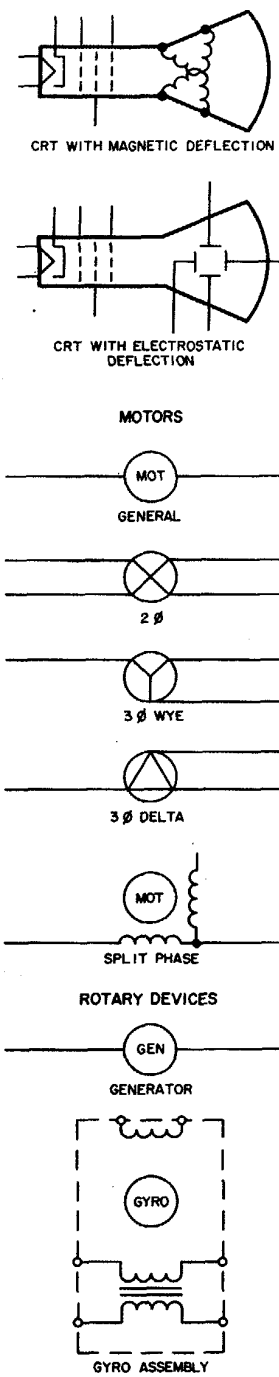

ROTARY DEVICES (CONT)

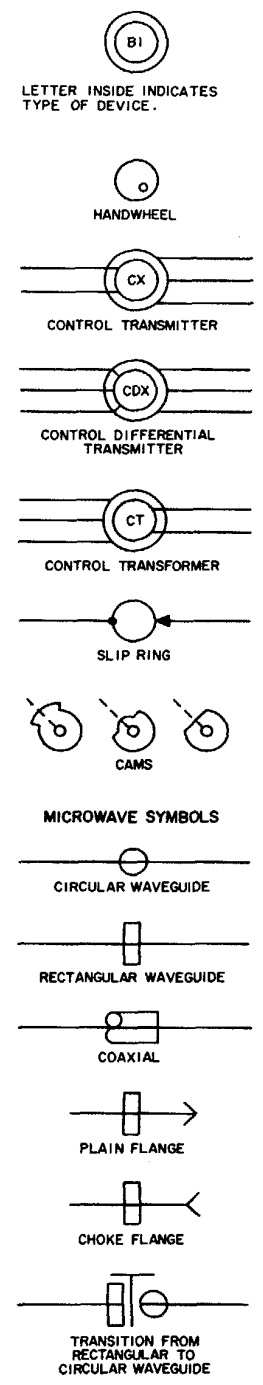

MICROWAVE SYMBOLS (CONT)

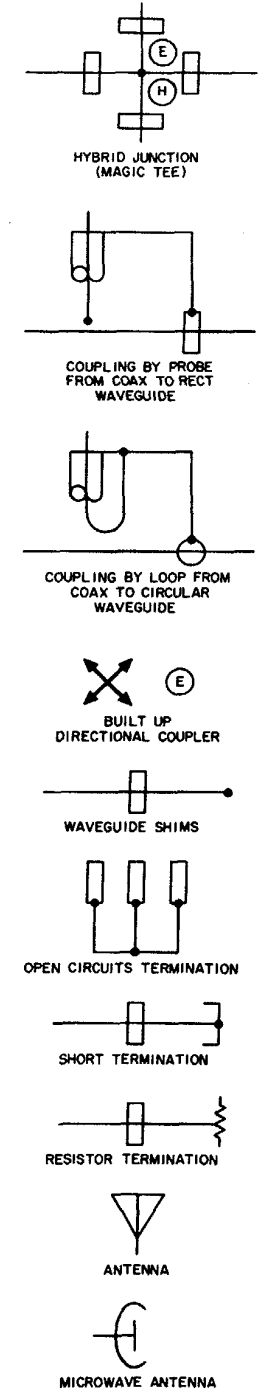

MICROWAVE SYMBOLS (CONT)

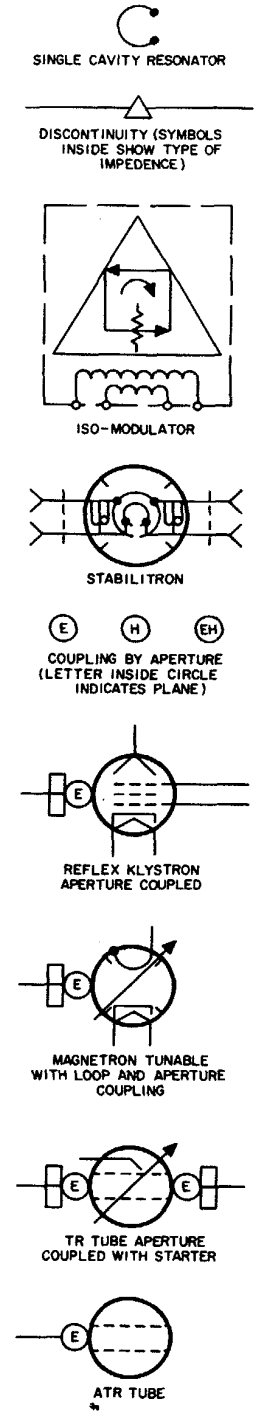

MICROWAVE SYMBOLS (CONT)

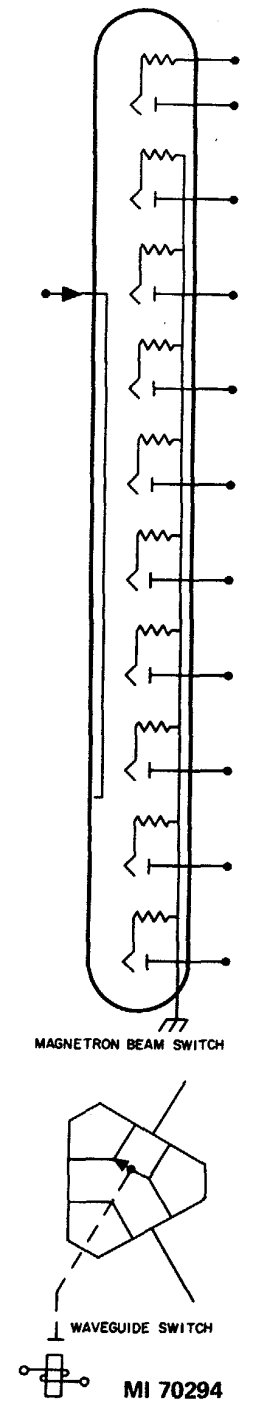

AUTOMATIC VALVES

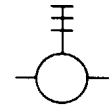

RELIEF VALVE

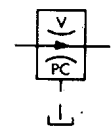

PRESSURE REGULATING VALVE (AIR)



PURGE VALVE

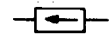

CHECK VALVE

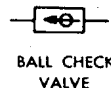

BALL CHECK VALVE



PISTON OPERATED VALVE

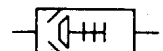

BACK PRESSURE VALVE

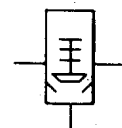

BLEED VALVE

AUTOMATIC VALVES



PRESSURE REDUCER

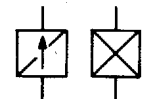

1 WAY 2 WAY FLOW REGULATOR

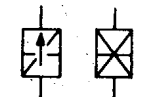

1 WAY 2 WAY RESTRICTOR

MANUAL VALVES

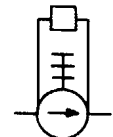

IN LINE RELIEF VALVE WITH INTEGRAL PILOT AND REMOTE MANUAL OPERATED PILOT

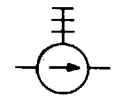

INLINE RELIEF VALVE



NEEDLE VALVE

MANUAL VALVES

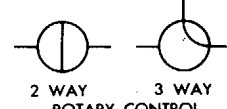

2 WAY 3 WAY ROTARY CONTROL VALVE

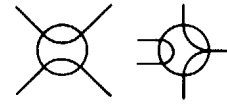

4 WAY 5 WAY ROTARY CONTROL VALVE



MANUAL CHECK VALVE

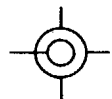

ROTARY SELECTOR VALVE

TRANSFER VALVES



2 WAY

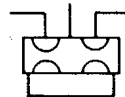

4 WAY

GENERAL SYMBOLS

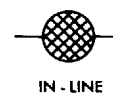

IN-LINE FILTER

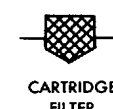

CARTRIDGE FILTER



ACCUMULATOR



HEAT EXCHANGER

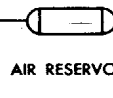

AIR RESERVOIR

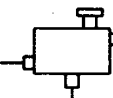

HYDRAULIC OIL RESERVOIR

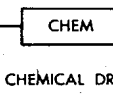

CHEMICAL DRYER

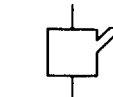

GAGE PROTECTOR (SPRING LOADED - ADJUSTABLE)

GENERAL SYMBOLS

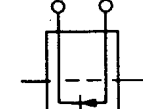

PRESSURE SWITCH CLOSED

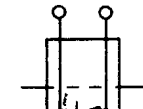

PRESSURE SWITCH OPEN

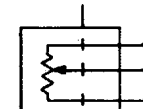

PRESSURE SENSOR TRANSDUCER

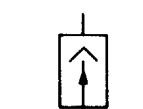

MOISTURE SEPERATOR

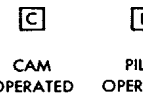

CAM OPERATED PILOT OPERATED

PUMPS AND ACTUATORS



AIR COMPRESSOR AND MOTOR

PUMPS AND ACTUATORS

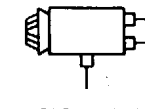

MOTOR DRIVEN PUMP

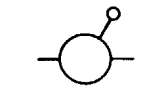

HAND PUMP

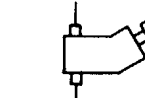

HYDRAULIC MOTOR

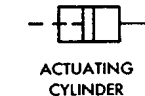

ACTUATING CYLINDER

CONNECTORS

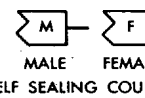

MALE FEMALE SELF SEALING COUPLINGS

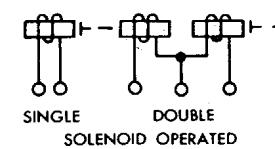

SINGLE DOUBLE SOLENOID OPERATED

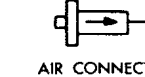

AIR CONNECTOR



CAP

GAGES



PRESSURE GAGE



FLOW METER



GRADUATED GAGE

HYDRAULIC LINES

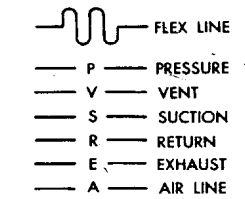

NO CONN CONNECTION

NOTES

1. ARROWS INSIDE BOXES INDICATE FREE FLOW
2. ARROWS OUTSIDE BOXES INDICATE CONTROLLED FLOW

MI 70295

By Order of the Secretary of the Army:

E. C. MEYER
General, United States Army
Chief of Staff

Official:

J. C. PENNINGTON
Major General, United States Army
The Adjutant General

Distribution:

To be distributed in accordance with DA Form 12-32, Section II, Direct and General Support Maintenance for the Improved HAWK Missile System.

RECOMMENDED CHANGES TO EQUIPMENT TECHNICAL PUBLICATIONS

 <div style="border: 1px solid black; border-radius: 15px; padding: 5px; margin: 10px auto; width: 80%; text-align: center;"> <p><i>THEN...JOT DOWN THE DOPE ABOUT IT ON THIS FORM. CAREFULLY TEAR IT OUT, FOLD IT AND DROP IT IN THE MAIL.</i></p> </div>		SOMETHING WRONG WITH PUBLICATION	
		FROM: (PRINT YOUR UNIT'S COMPLETE ADDRESS)	
		DATE SENT	
PUBLICATION NUMBER		PUBLICATION DATE	PUBLICATION TITLE
IN THIS SPACE, TELL WHAT IS WRONG AND WHAT SHOULD BE DONE ABOUT IT.			
BE EXACT PIN-POINT WHERE IT IS			
PAGE NO.	PARA-GRAPH	FIGURE NO.	TABLE NO.
PRINTED NAME, GRADE OR TITLE AND TELEPHONE NUMBER		SIGN HERE	

The Metric System and Equivalents

Linear Measure

1 centimeter = 10 millimeters = .39 inch
 1 decimeter = 10 centimeters = 3.94 inches
 1 meter = 10 decimeters = 39.37 inches
 1 dekameter = 10 meters = 32.8 feet
 1 hectometer = 10 dekameters = 328.08 feet
 1 kilometer = 10 hectometers = 3,280.8 feet

Weights

1 centigram = 10 milligrams = .15 grain
 1 decigram = 10 centigrams = 1.54 grains
 1 gram = 10 decigrams = .035 ounce
 1 decagram = 10 grams = .35 ounce
 1 hectogram = 10 decagrams = 3.52 ounces
 1 kilogram = 10 hectograms = 2.2 pounds
 1 quintal = 100 kilograms = 220.46 pounds
 1 metric ton = 10 quintals = 1.1 short tons

Liquid Measure

1 centiliter = 10 milliliters = .34 fl. ounce
 1 deciliter = 10 centiliters = 3.38 fl. ounces
 1 liter = 10 deciliters = 33.81 fl. ounces
 1 dekaliter = 10 liters = 2.64 gallons
 1 hectoliter = 10 dekaliters = 26.42 gallons
 1 kiloliter = 10 hectoliters = 264.18 gallons

Square Measure

1 sq. centimeter = 100 sq. millimeters = .155 sq. inch
 1 sq. decimeter = 100 sq. centimeters = 15.5 sq. inches
 1 sq. meter (centare) = 100 sq. decimeters = 10.76 sq. feet
 1 sq. dekameter (are) = 100 sq. meters = 1,076.4 sq. feet
 1 sq. hectometer (hectare) = 100 sq. dekameters = 2.47 acres
 1 sq. kilometer = 100 sq. hectometers = .386 sq. mile

Cubic Measure

1 cu. centimeter = 1000 cu. millimeters = .06 cu. inch
 1 cu. decimeter = 1000 cu. centimeters = 61.02 cu. inches
 1 cu. meter = 1000 cu. decimeters = 35.31 cu. feet

Approximate Conversion Factors

<i>To change</i>	<i>To</i>	<i>Multiply by</i>	<i>To change</i>	<i>To</i>	<i>Multiply by</i>
inches	centimeters	2.540	ounce-inches	Newton-meters	.007062
feet	meters	.305	centimeters	inches	.394
yards	meters	.914	meters	feet	3.280
miles	kilometers	1.609	meters	yards	1.094
square inches	square centimeters	6.451	kilometers	miles	.621
square feet	square meters	.093	square centimeters	square inches	.155
square yards	square meters	.836	square meters	square feet	10.764
square miles	square kilometers	2.590	square meters	square yards	1.196
acres	square hectometers	.405	square kilometers	square miles	.386
cubic feet	cubic meters	.028	square hectometers	acres	2.471
cubic yards	cubic meters	.765	cubic meters	cubic feet	35.315
fluid ounces	milliliters	29.573	cubic meters	cubic yards	1.308
pints	liters	.473	milliliters	fluid ounces	.034
quarts	liters	.946	liters	pints	2.113
gallons	liters	3.785	liters	quarts	1.057
ounces	grams	28.349	liters	gallons	.264
pounds	kilograms	.454	grams	ounces	.035
short tons	metric tons	.907	kilograms	pounds	2.205
pound-feet	Newton-meters	1.356	metric tons	short tons	1.102
pound-inches	Newton-meters	.11296			

Temperature (Exact)

°F	Fahrenheit temperature	5/9 (after subtracting 32)	Celsius temperature	°C
----	---------------------------	-------------------------------	------------------------	----

